

WARRANTY

We strive to offer high-quality products, and we also try our best to satisfy each and every customer that orders from us with product or service as needed.

Each customer must provide a record of their order such as the order number, or item receipt for any items that are out of the warranty period you may also still receive replacement parts by purchasing them with our company if they are available.

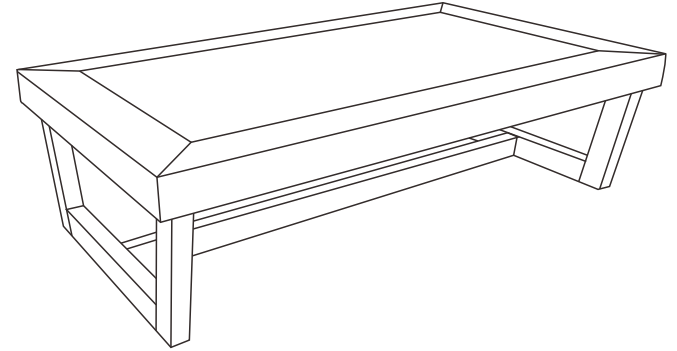

NOTE:

This brochure contains IMPORTANT safety info. Please read and keep for future reference.

MAINTAINANCE AND WARNING

- Keep furniture away from heat and fire.
- Keep furniture away from sharp objects.
- Do not clean furniture with harsh cleansers or polish. Do not use detergents, Solvents, abrasives, spray packs or leather cleaner. Use non-color mild soap with warm water clean spills(Mix 1:10 soap to water)
- Do not place furniture under direct sunlight, material will possibly fade over time.
- Do not jump or strike on the furniture.
- Do not write on furniture without a padded barrier to protect the surface.
- Not for commercial use, For residential use only.



Weight Limitation

400LBS

PARTS LIST

Ax1

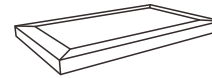

Table top

Cx1



Stretcher

Bx 2

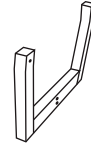

Leg frame

HARDWARE and TOOL LIST

① x2



M6*40MM
Bolt

② x4



M6*30MM
Bolt

③ x1



Allen key

④ x2



Wood dowel

⑤ x2



Plastic cover

Be sure to check all packing materia fit the packing list. Carefully for small parts, which may have come loose inside the carton during shipment.

ASSEMBLY INSTRUCTIONS

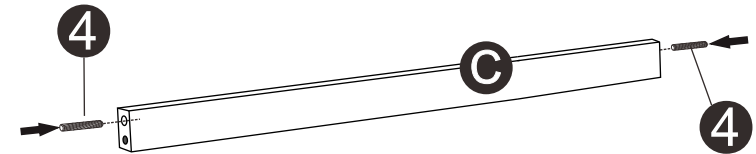

STEP 1: Insert wood dowel(4) into holes at both ends of stretcher (C).

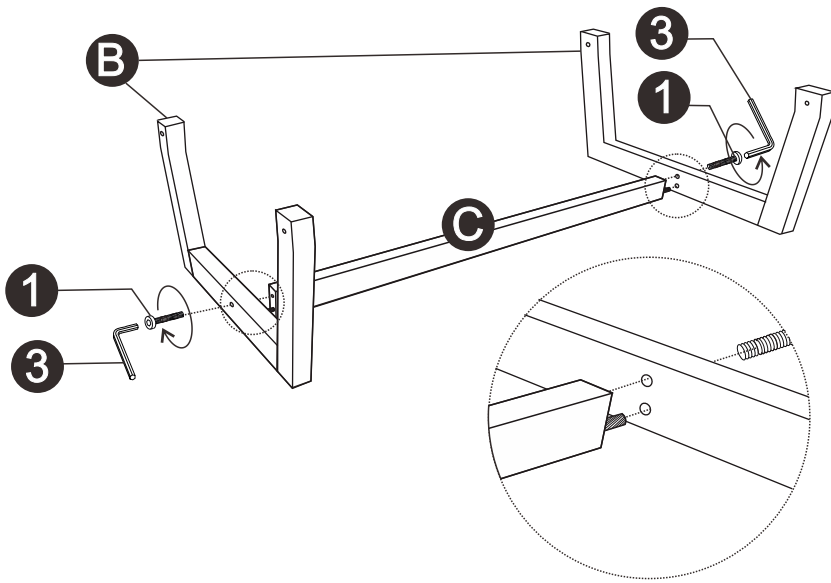

STEP 2: Connect both leg frames(B) with stretcher(C), lock with bolt (1) and allen key(3).

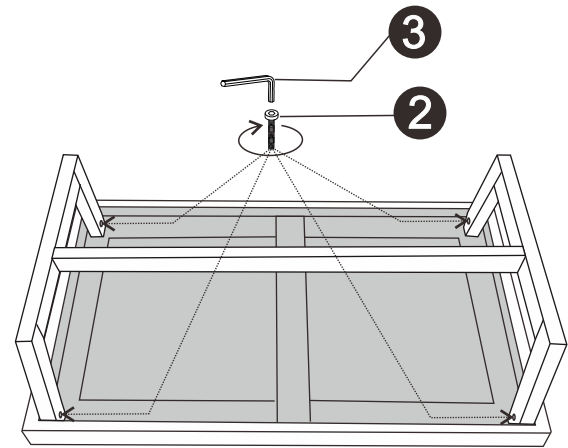

STEP 3: Place table top(A) upside down on clean and flat floor, then place leg frame(step 2) into the below box. Lock with bolt(2) and allen key (3).

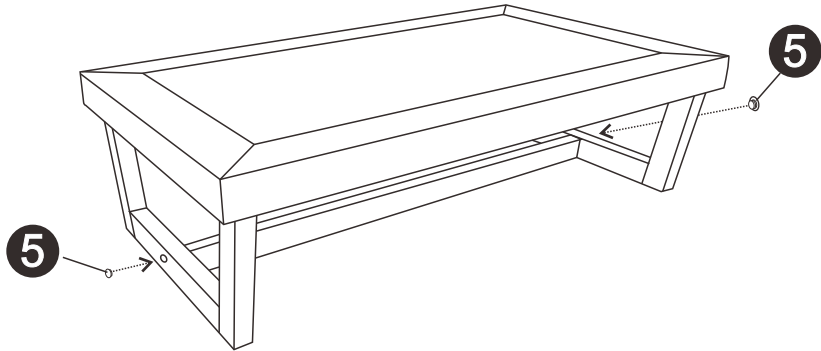

STEP 4: Cover the screw holes with plastic covers(5), assembly completed.