

Jack Stonehouse

ASSEMBLY INSTRUCTION

MANUAL AWNING

CODE : EX08058/EX08098

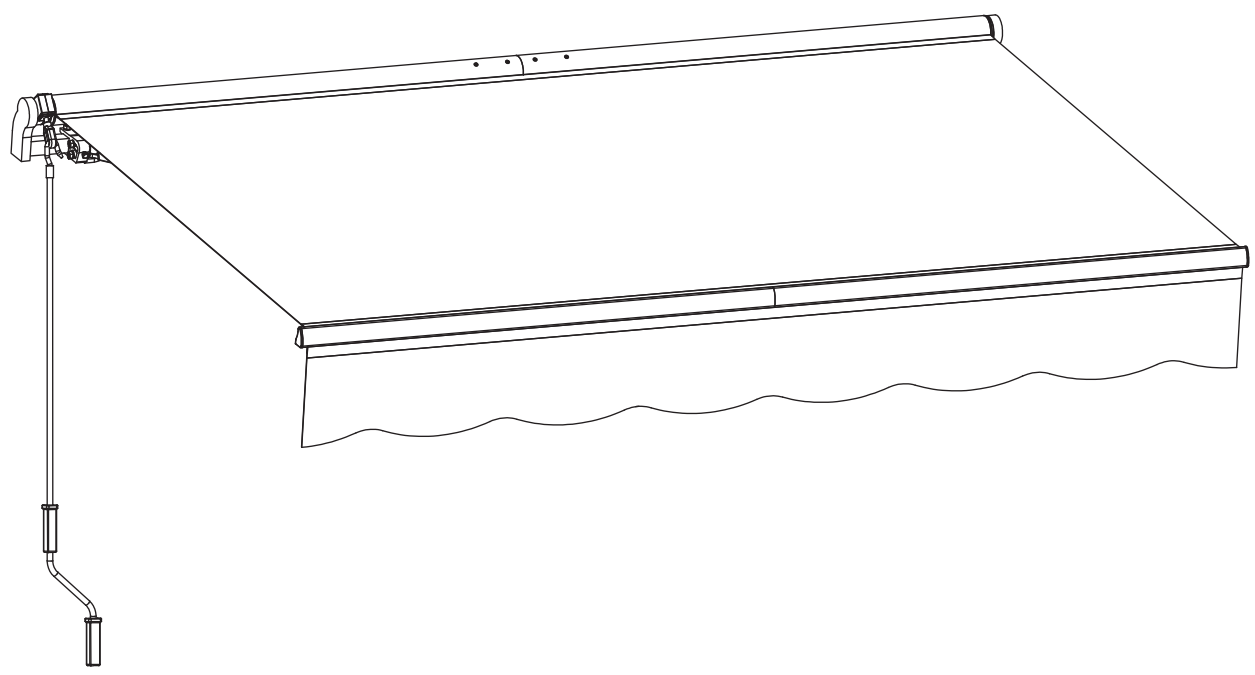

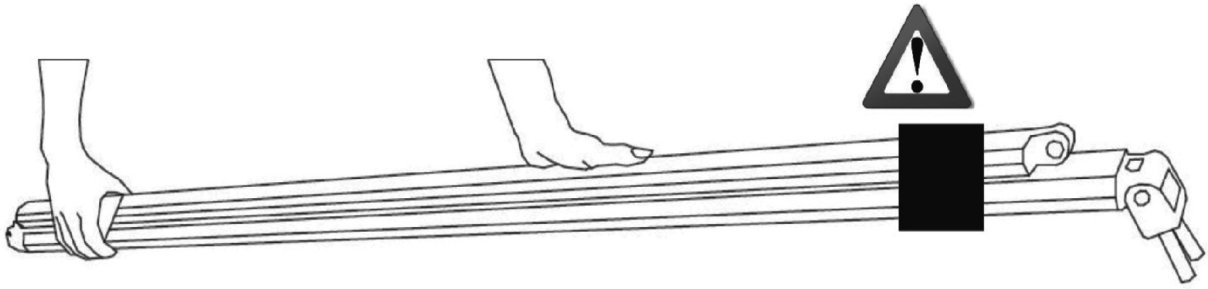

WARNING!

AWNING ARMS CAN CAUSE INJURY

ONLY CUT AWNING ARM TAPES
AFTER AWNING IS FULLY ASSEMBLED

X wrong



✓ right



WARNING

WILL CAUSE INJURY!





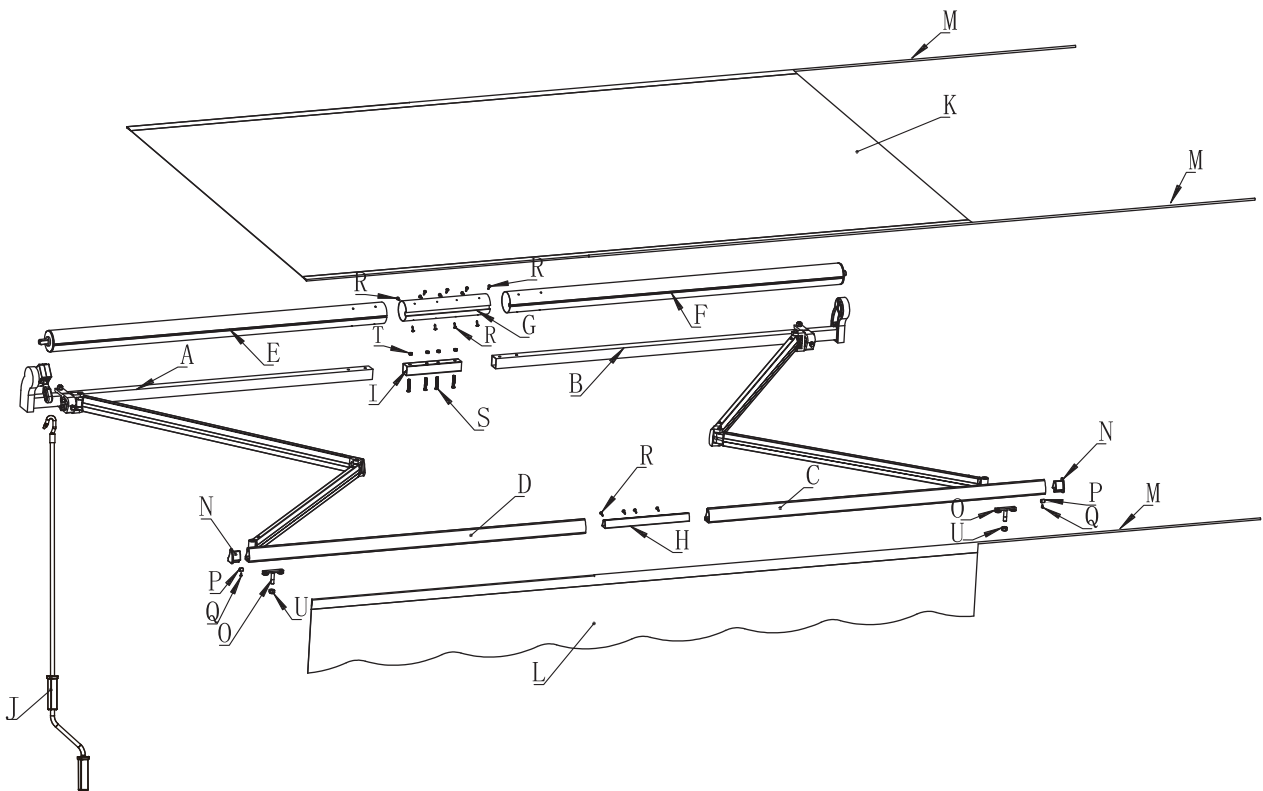





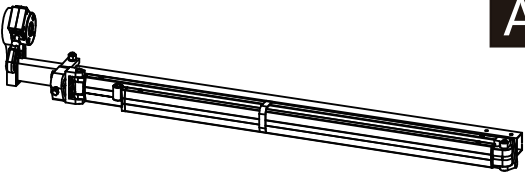
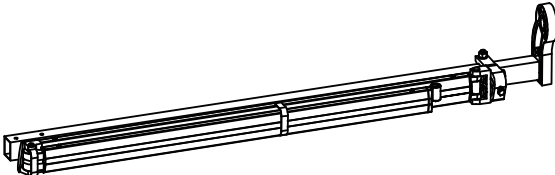



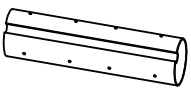

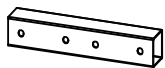

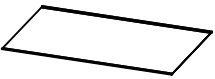

ONLY CUT AFTER FULLY ASSEMBLED

- | | | |
|--------------------------------|--|--------------------|
| A. Torsion bar with Arm(Left) | J. Hand Crank | S. M6X40 |
| B. Torsion bar with Arm(Right) | K. Fabric | T. M6 |
| C. Fornt bar(Right) | L. Valance | U. M10 |
| D. Fornt bar(Left) | M. Fabric Liner | V. M8X55 |
| E. Roller(Left) | N. Front bar caps(Left and Right) | W. M8 |
| F. Roller(Right) | O. Armbar Link | X. Expansion Screw |
| G. Roller connector | P. Plastic Bolt for cover and Fabric Liner | Y. Wall Brackets |
| H. Front bar connector | Q. St 3x10 | |
| I. Torsion bar connector | R. St 14x15 | |



PARTS LIST

Ensure all listed parts are present before beginning assembly

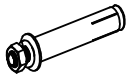
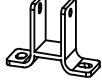
			
			
			
			
			
		 St3 X10	 St4 X15
 M6 X40	 M6	 M10	 M8 X55
 M8			

STEP 1: Thread the fabric liner (M) through the loop in the Valance (L) and cut to length.

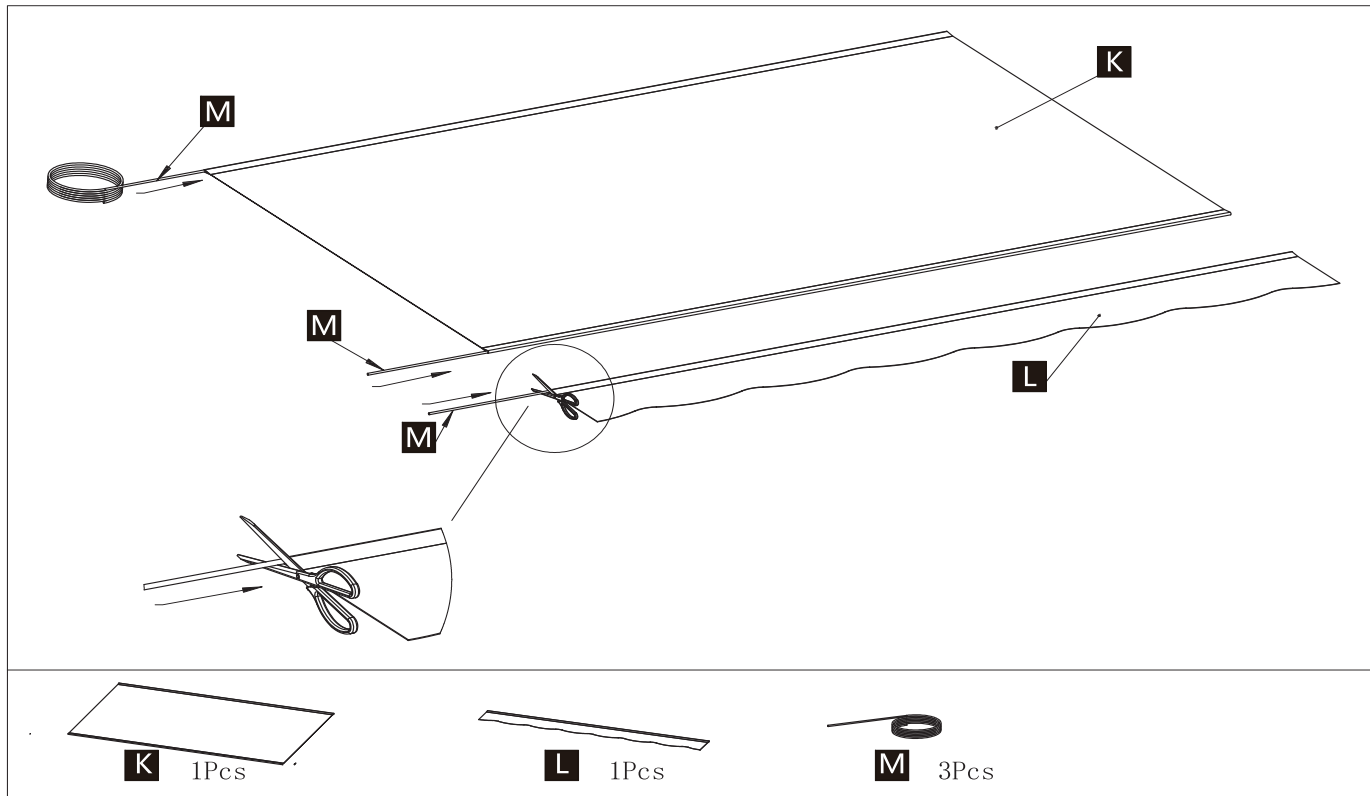

STEP 2: o Connect Front Bar LEFT (D) to Front Bar Connector (H) secure with 2 screws (R)
o Connect Roller LEFT (E) to Roller Connector (G) secure with 6 screws (R)

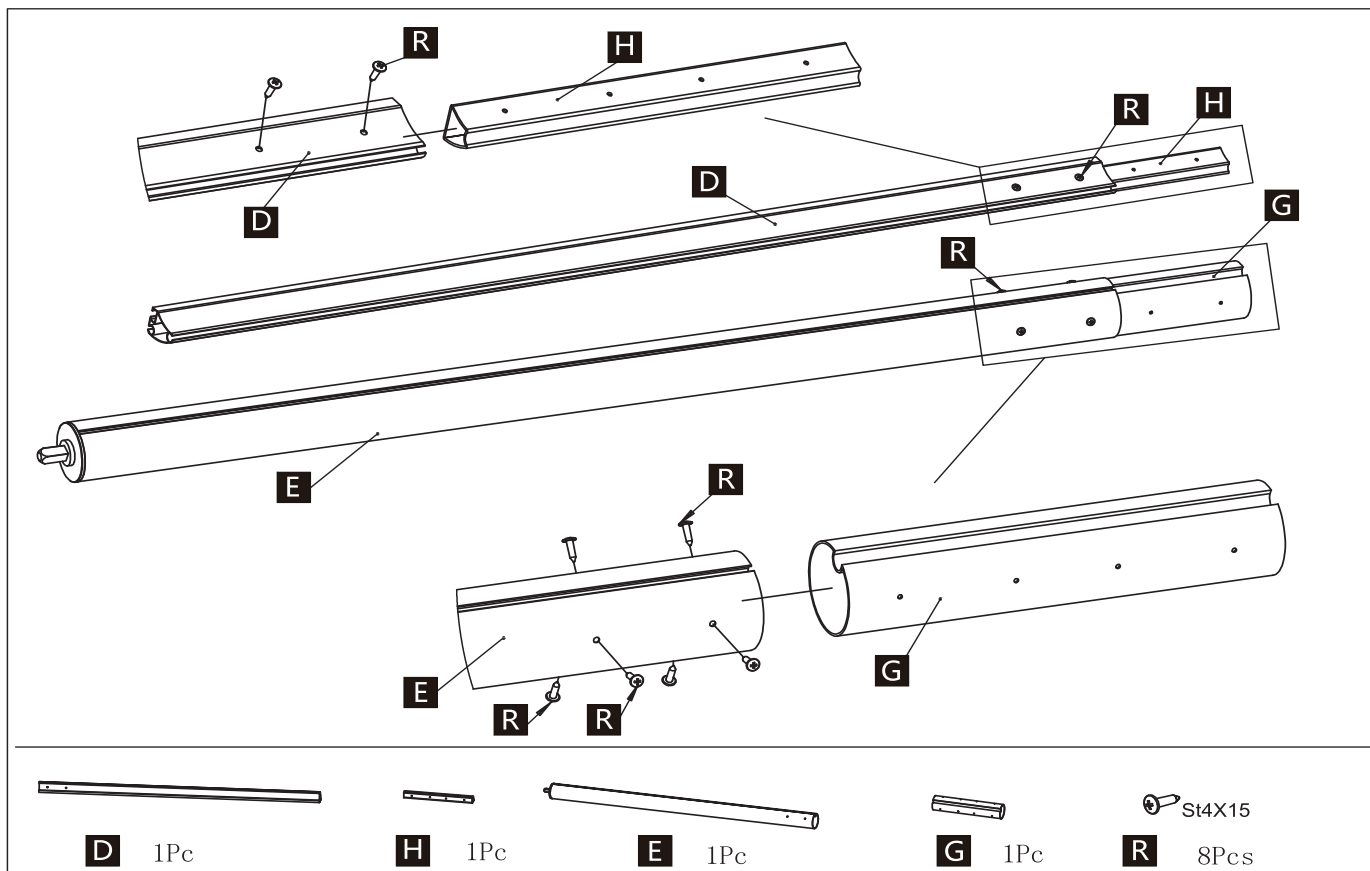

- STEP 3:**
- o Slide both Roller LEFT (E) and Roller RIGHT (F) onto the back (wall-mounted) end of the fabric. Secure with 6 screws (R).
 - o Slide both Front Bar LEFT (D) and Front Bar RIGHT (C) onto the front of the fabric. Secure with 2 screws (R).

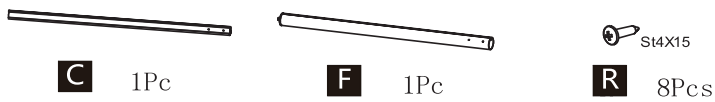
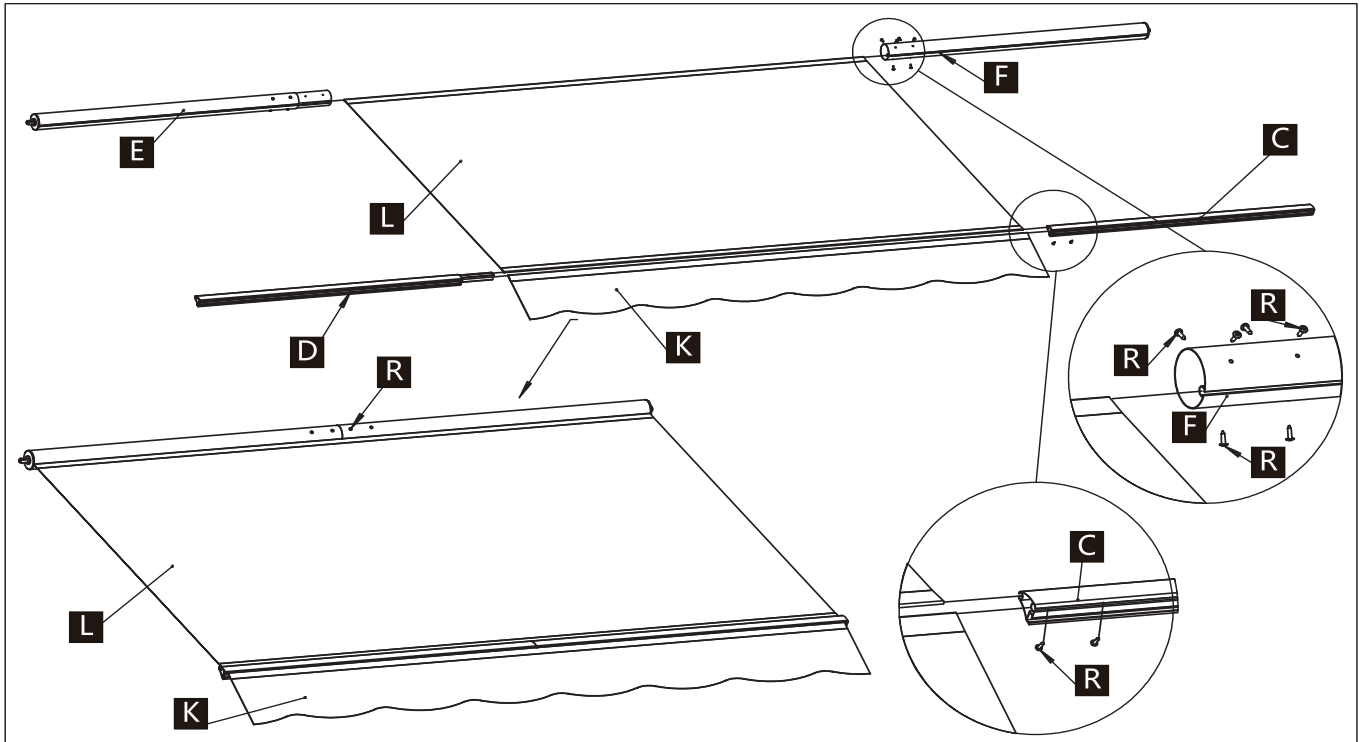

- STEP 4:**
- o Place the Armband Link (O) into the front section of the Front Bar on each side.
 - o Insert Plastic Bolt (P) into the back section of the Front Bar and lock it in place with Screw (Q).
 - o Tap the Front Bar Caps (N) onto each end.

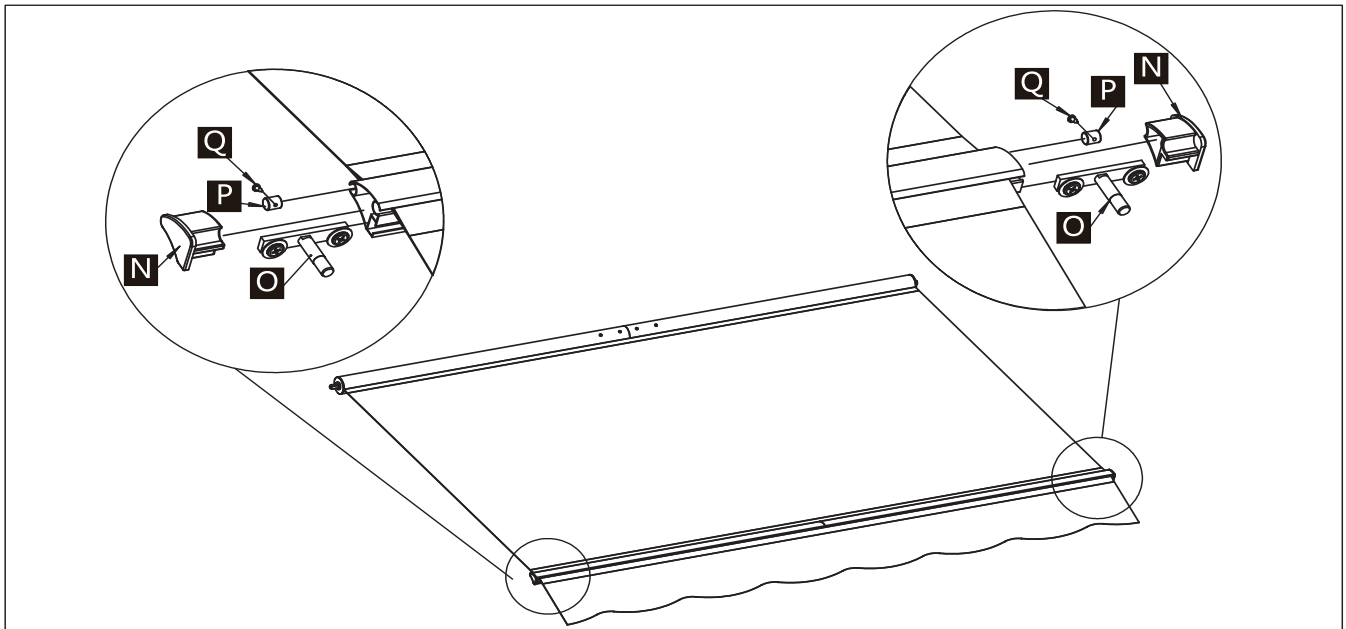

STEP 5: Roll the awning fabric as tightly as possible.

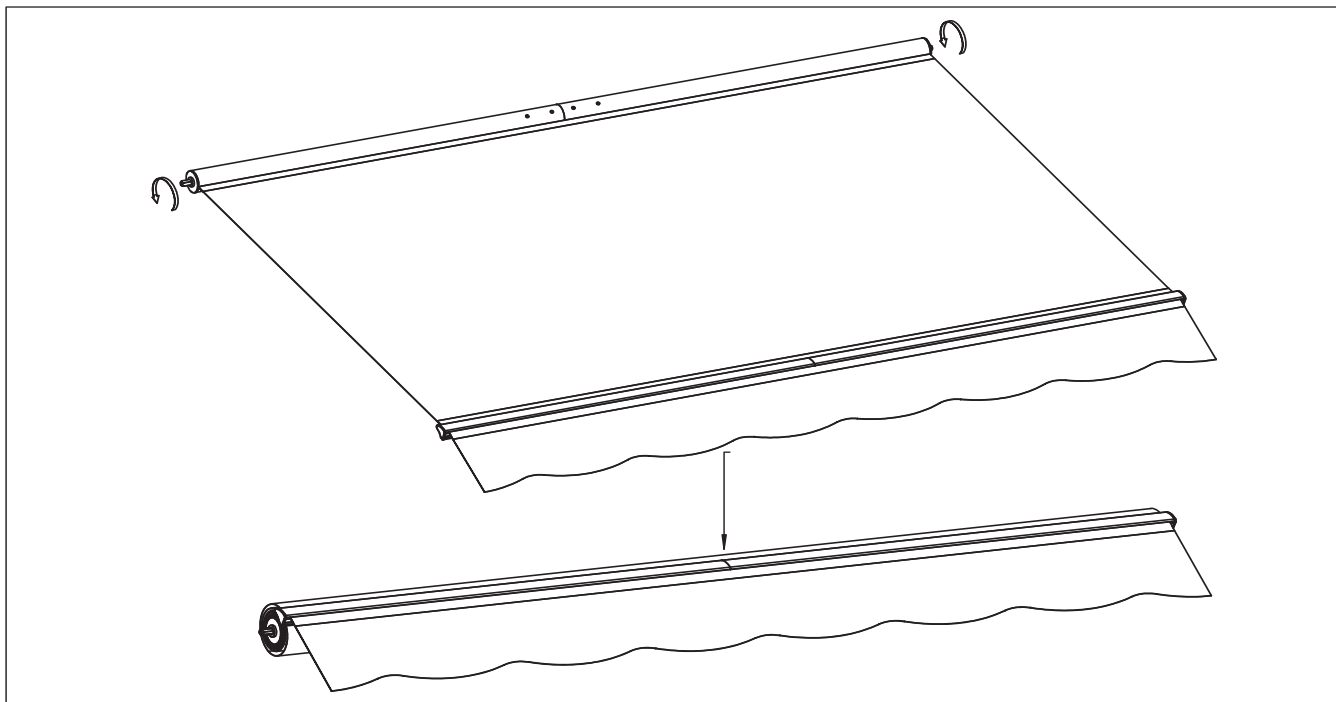

- STEP 6:
- o Connect the Left Torsion Bar with Arm (A) to the Torsion Bar Corrector (I) and secure with 2 bolts and washers (S & T).
 - o Attach the Torsion Bar Corrector (I) to the Right Torsion Bar with Arm (B) – Do not secure with bolts yet.
 - o Place the fabric roller into the square hole of the gear box on the left and the round hole on the roller support on the right
 - o Push each side together to ensure the roller is secure.
 - o Once secure, connect the Right Torsion Bar with Arm (B) to the Torsion Bar Corrector (I) with the remaining 2 bolts and washers (S & T).

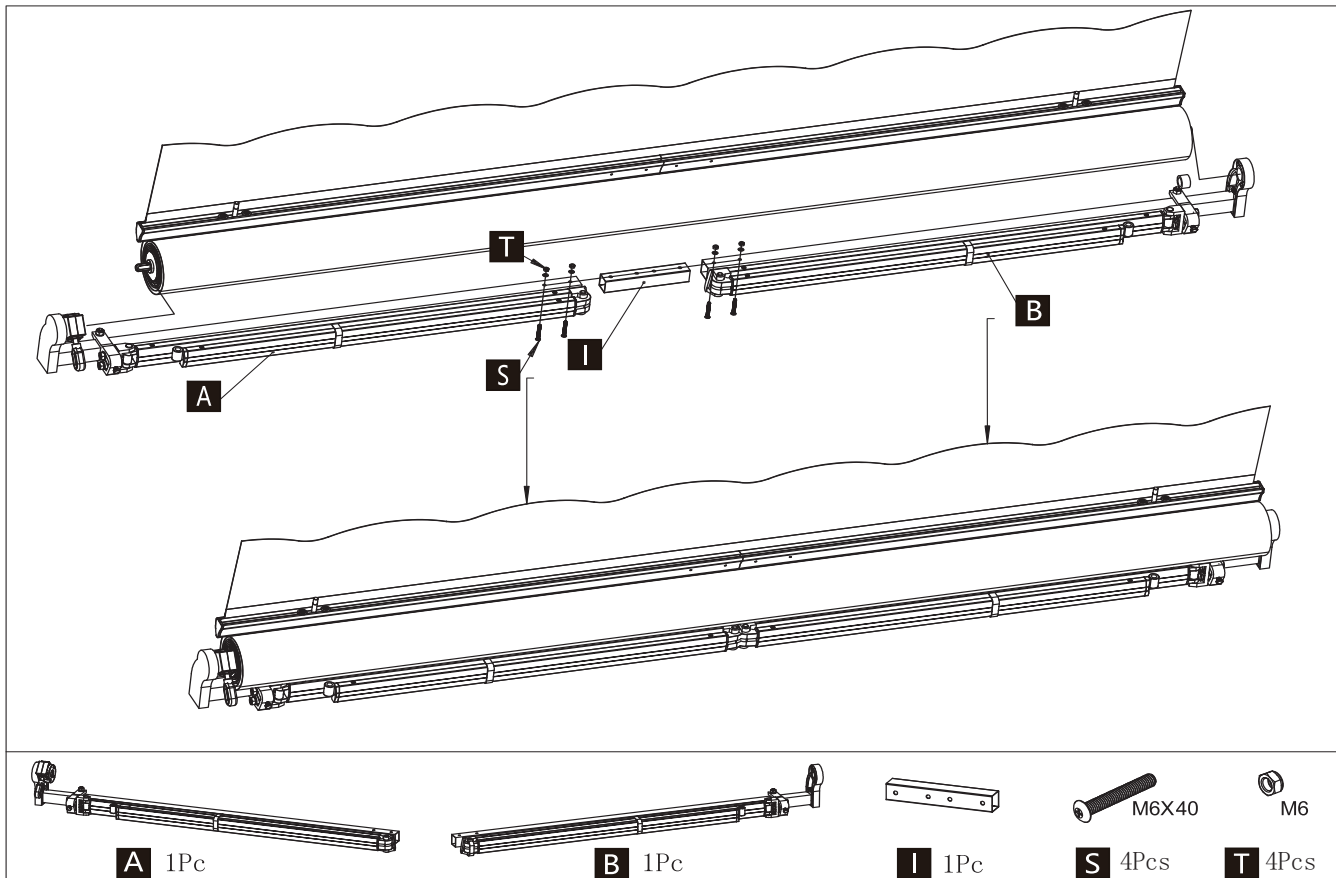

- STEP 7:
- o Slide Armbar link part (O) until you can connect to the front of the Torison bar arms (A&B).
 - o Once connected tighten part (O) into position on both sides.
 - o Place bolts M10 part (U) onto part (O) and secure to 90% tightness.

Note: The Front bar is Placed flat with the Roller.

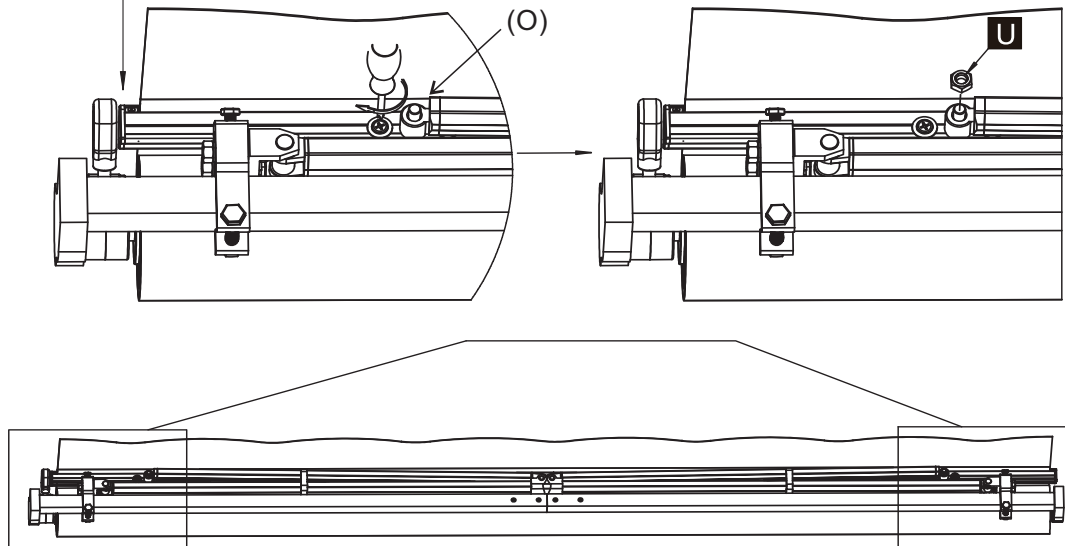

M10



2Pcs

- STEP 8:
- o Finishing awning assembly. Cut the safety connectors that hold the arms and torsion bar.
 - o The awning is now ready for wall mounting

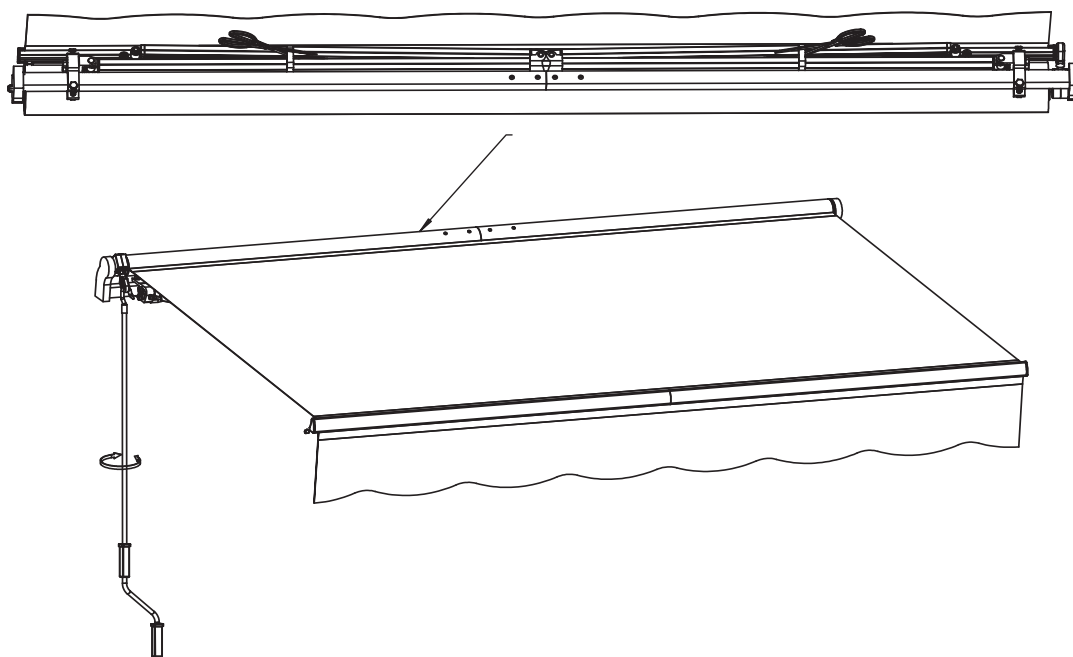

🔧 INSTALLATION

Notes About Wall Mounting

This awning can be secured to reinforced concrete, brick, and wood, however this awning kit only supplies screws suitable for mounting to brick and reinforced concrete walls.

If you wish to secure your awning to wood, please use carriage bolts of adequate length and of an appropriate diameter to secure the awning to wood beams. The bolt size depends on the size of wood; these can be purchased at a hardware store. We recommend a professional installer for the safest and most secure installation.

Never attempt to secure the wall brackets to loose wall stones or any surfaces that are not absolutely firm!



CAUTION: Proper location of the brackets is the most important aspect of the awning installation. It is critical that you fasten all the mounting brackets to studs, joists, headers or other major structural components.



WARNING: Failure to securely fasten all the brackets to the wall could result in the collapse of the awning and cause personal injury or death.

Mounting Height

It is important to take the awning's drop area into consideration before bolting your wall mounts. If you would like to mount above a patio door, for example, please leave at least 8 inches above the door frame and be sure that the awning does not interfere with opening and closing the door. The drop angle can only be changed minimally, so take this into consideration when deciding where to place your awning.

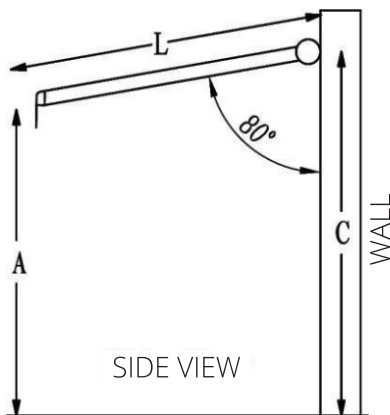

We recommend that the awning surface make an angle of about 80 degrees to the wall when open.

- **Recommended Installation Height:** 8-12 feet.
- **The ideal drop angle (when fully extended) has already been set in the factory,** so you may not have to change the pitch/angle.
- **The awning has a drop** of 24 inches when at a slope, or 15 degrees.

CALCULATIONS:

You can use the following formula to calculate the appropriate angle.

$$C = A + 0.17 * L$$

A = The desired height of the front bar

L = The length of the arm stretched out

C = The height of the wall brackets

STEP 1: Measuring the Mount Site

1. Measure the length of your awning along the wall where you intend to install it. This line will be the highest point of your awning and align with the top of the wall bracket. Use a leveler to make a chalk line across the distance.
2. **Important: double check that the line is level all the way across.**
3. Be sure that the line is centered over the patio door, window, or other feature, if applicable.
4. Now that you have a straight, centered line, measure the middle point and mark it. This is where the middle wall bracket will be installed.
5. Take a wall bracket and place the top of it, completely level, under the line, as shown in the diagram below. With chalk or a pencil, mark the position of all the wall brackets and their bolt holes.

Awnings < 10.8 Feet	Requires only 2 wall brackets total: one for each end of the torsion bars.
Awnings 10.8 - 14 Feet	Requires 3 wall brackets total: one for each end, and one in the middle.
Awnings 14.5 - 20 Feet	Requires 4 wall brackets total: one for each end, and two in the middle.

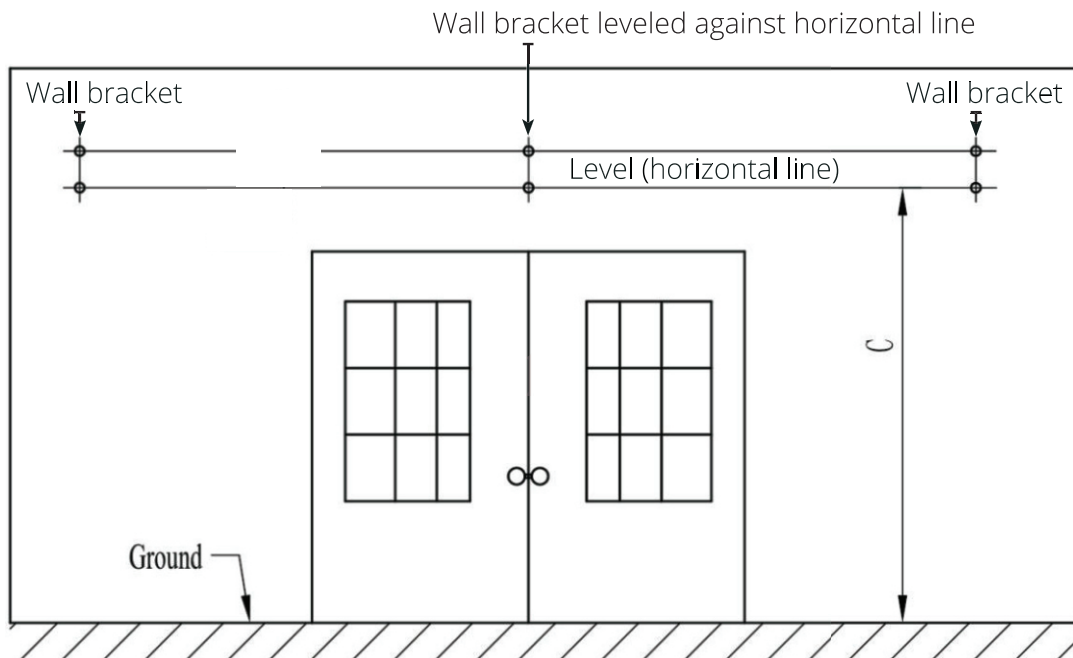

STEP 2: Drilling the Bolt Holes

1. Now that you have a straight, level line across the wall with the locations of the wall brackets and their bolt holes marked, you will drill holes to mount the brackets.
2. Using a 14mm masonry drill bit, drill the first bolt hole approximately 4 inches (9 centimeters) deep, as shown in the diagram. This must be drilled through solid brick or concrete to offer the necessary support for the awning.
3. Drill the remaining holes exactly as in step 2.

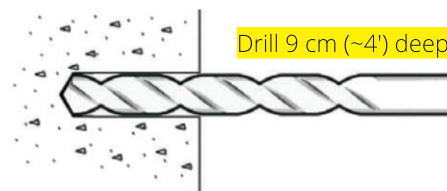

!! IMPORTANT: All bolt holes must be aligned vertically and horizontally to ensure that the awning hangs straight.
Double check alignment before drilling if you are not certain.

!! IMPORTANT: The diameter and depth of your mounting holes must be the same size as the expansion bolts.

STEP 3: Preparing For Mounting

1. Now that all of your holes are drilled, insert the expansion bolts.
2. It may be necessary to drive the bolts in with a wooden (or other non-metallic) mallet.



If a mallet is necessary for installation, we recommend placing the nut on the screw (loosely) before hammering to avoid damaging the bolt threads.

3. Make sure that the bolts are firmly in place, yet let them stick out of the wall approximately 1 inch or less - enough that the wall bracket can be installed onto them.
4. Firmly tighten the bolts with a 19mm hex key. It is best to use the hex key with a closed end rather than an open end to avoid damaging the nut, should it slip.

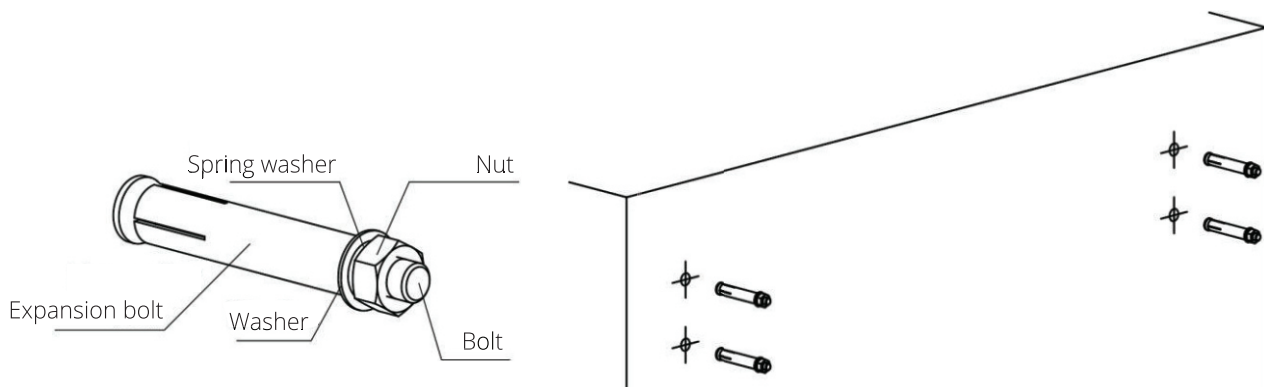

STEP 4: Mounting the Wall Brackets

1. Now that the bolts are securely in the wall, remove the nuts that are loosely placed over the bolts.
2. Place a wall bracket onto one set of bolts. This should be an easy fit if the bolt holes are properly aligned.
3. Once the wall bracket is resting on the bolts, place a washer over the bolt, then secure it with a nut, as shown in the diagram.
4. The **brackets MUST sit firmly on the wall**. If there is any movement, you must tighten it more.
5. Repeat this step for each of the wall brackets. Once you do this, all wall brackets will be securely in place.

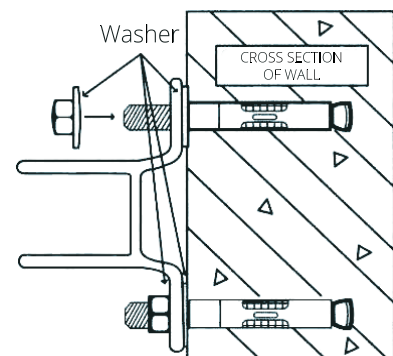

STEP 5: Mounting the Awning

1. Now that the wall brackets are secure and in place, it is time to install the awning onto the brackets.
2. At least two ladders or sturdy chairs are required to install the awning.
3. Put the original expansion bolts on the wall brackets and tighten them.
4. Finally, fasten all expansion bolts.
5. Using the hand crank or a motor (if applicable), fully open your awning. The front bar should be level.
6. **Congratulations! Your awning is installed. If you are happy with the height of the front bar (awning pitch), sit back and enjoy! If not, please read on.**

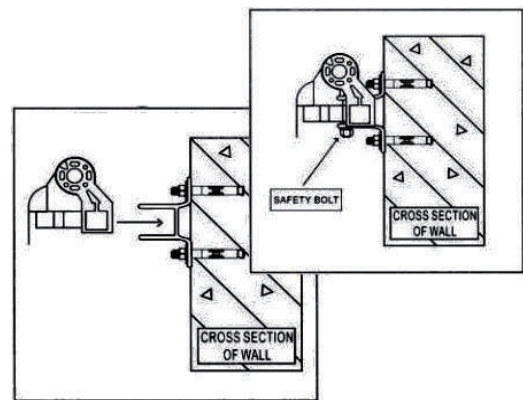

OPTIONAL INSTALLATION

ADJUSTING THE AWNING PITCH/ANGLE

Each awning comes with a pre-set pitch (angle) that is considered ideal. However, if you need to make an adjustment, it can be done in just a few easy steps.

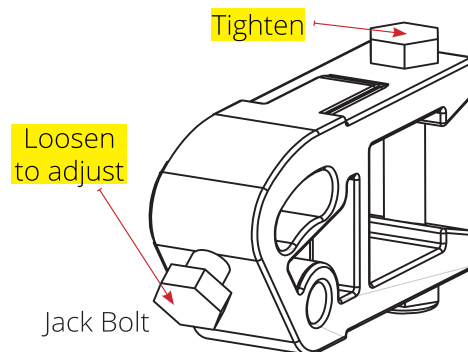
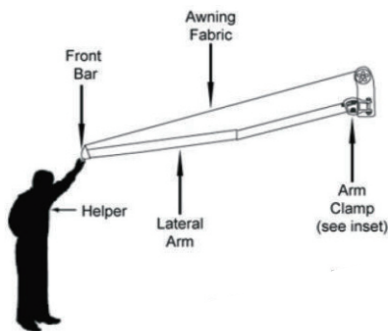

!!! IMPORTANT: Raising the front bar will reduce the pitch (angle) of the fabric, thus increasing the risk of rain water pooling on the fabric. To prevent the awning from collapsing due to rain water weight, you must retract the awning when unattended. Failure to do so could result in a broken awning or personal injury.

Note: Be sure that the front bar is adjusted to be completely even. Any misalignment will result in improper retraction.

Common mistakes

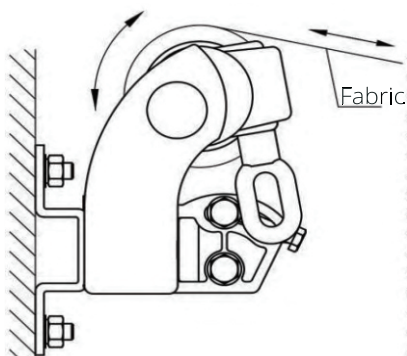

Correct operation

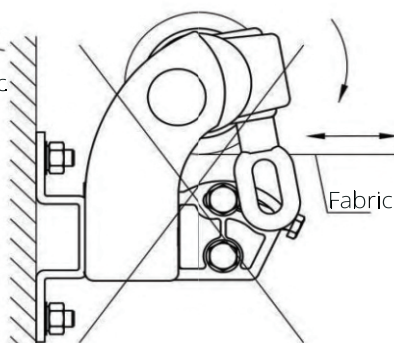

Wrong operation

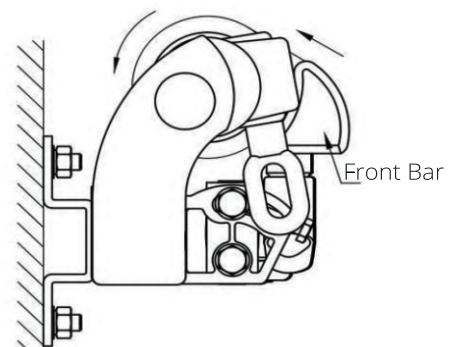

WARNING: When the front bar touches the roller as shown in the figure, don't try to make them closer, otherwise the product may be damaged.

Jack Stonehouse

For further information, additional parts, accessories or other queries please contact:



01604 537900



35 Tameside Drive,
Birmingham,
B35 7AG

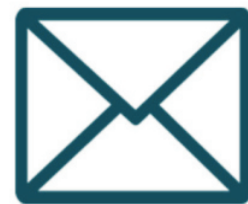

sales@jackstonehouse.com



www.jackstonehouse.com

FOLLOW US



@Jackstonehouseuk



Jack Stonehouse