











Assembly Instructions

CAUTION: You must read these Assembly Instructions before you proceed.

Care & Maintenance

- ⊘  • Not for commercial use. For residential use only.
- ⊘  • Do not put hot items directly on furniture surface.
- ⊘  • Do not clean furniture with harsh cleansers or polish.
- ✓  • To obtain the longest lifespan of your outdoor products, minimizing exposure to direct sunlight is recommended.
- ⊘  • Children should not climb or jump on the furniture.
- ⊘  • Do not write on furniture without a padded barrier to protect the surface.
- ✓  • To obtain the longest lifespan of your outdoor products, avoid extended and lengthy exposure to rain, snow, and direct sunshine. Whenever possible cover the product and /or place under patio or awnings.
- ⊘  • Stains may be removed with mild soap solution and damp cloth.
- ✓  • Keep away from sources of ignition.
- ✓  • Dust and pick-up spills using a clean, non-colored, lint- free cloth.

Please look in Table Leg for hardware packs.

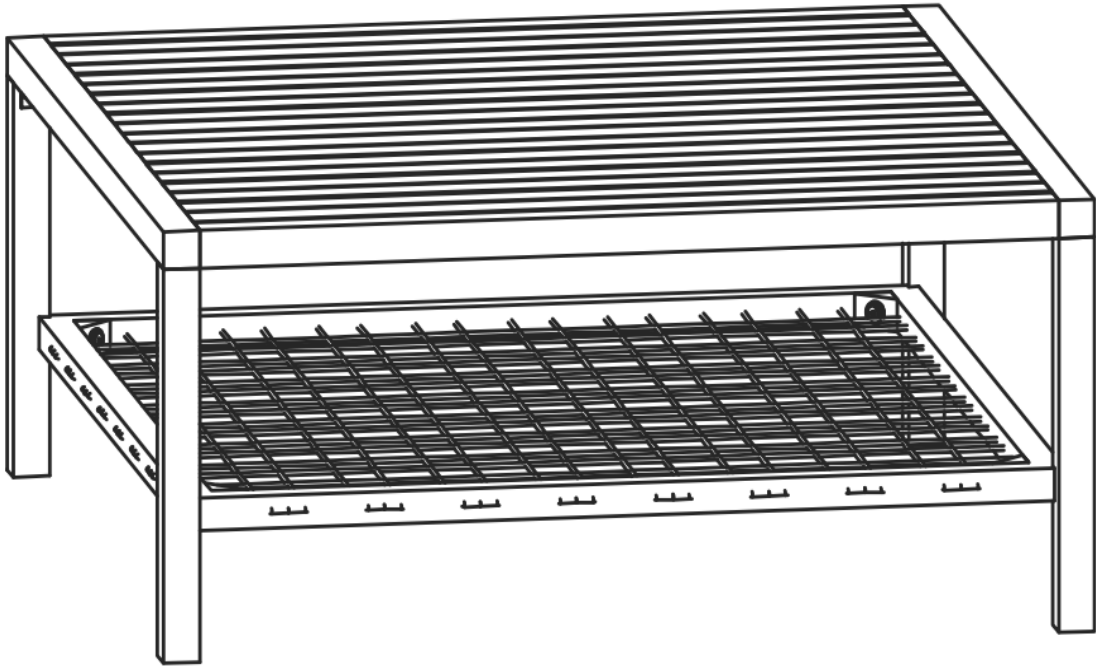

TABLE

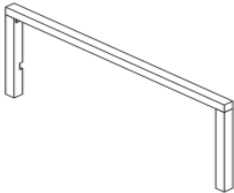
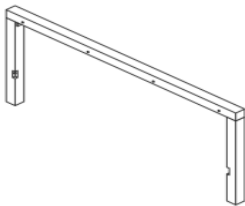
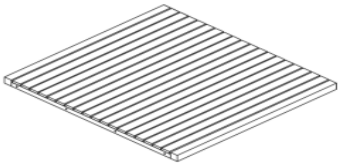
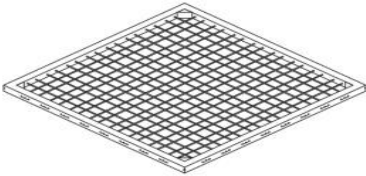

Parts List:

Label	Picture	Description	QTY
A		Left Leg	1
B		Right Leg	1
C		Table Top	1
D		Table Shelf	1

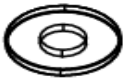
Hardware:

No	Picture	Description	QTY
①		Bolt (M6*60mm)	9
②		Flat Washer (M6)	5
③		Screw (M6*90mm)	5
④		Allen Wrench	2

Assembly Preparation:

Before Beginning Assembly:

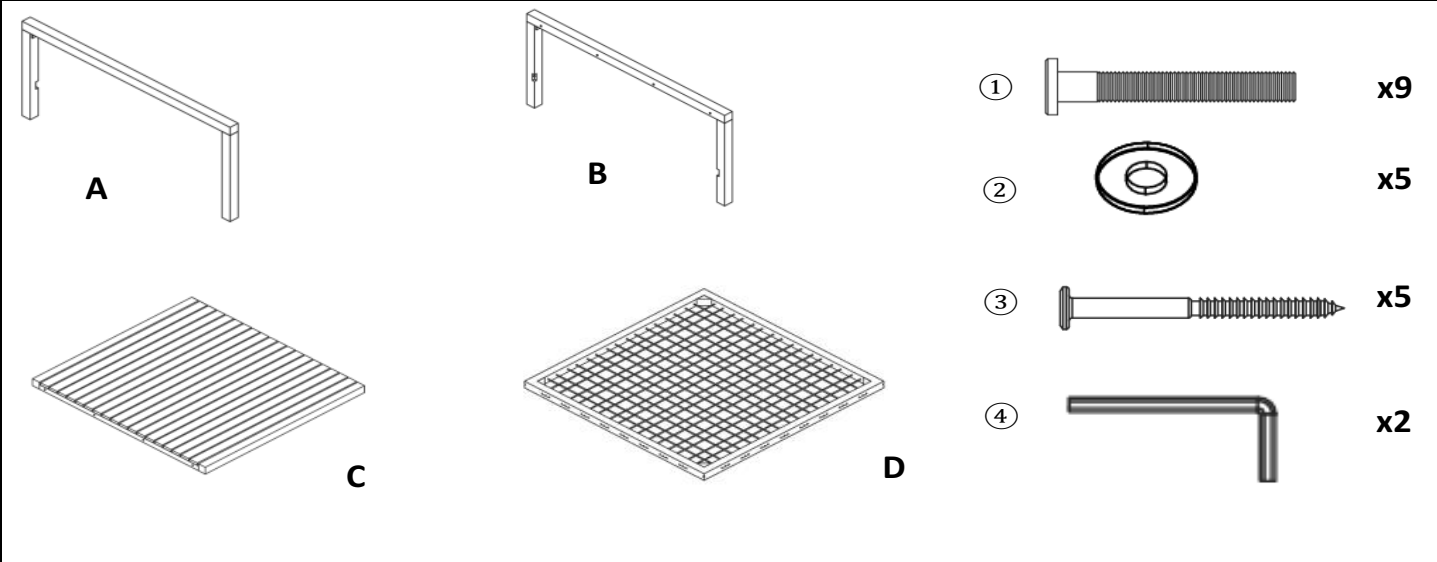

- Read instructions, cover to cover-
- Have 2 adults on hand for assembly-
- Do not assemble on flooring or carpet-
- Assemble on a clean non-marring surface (packing foam)-
- Save all packaging until finished-

Assembly Steps:

Overview:

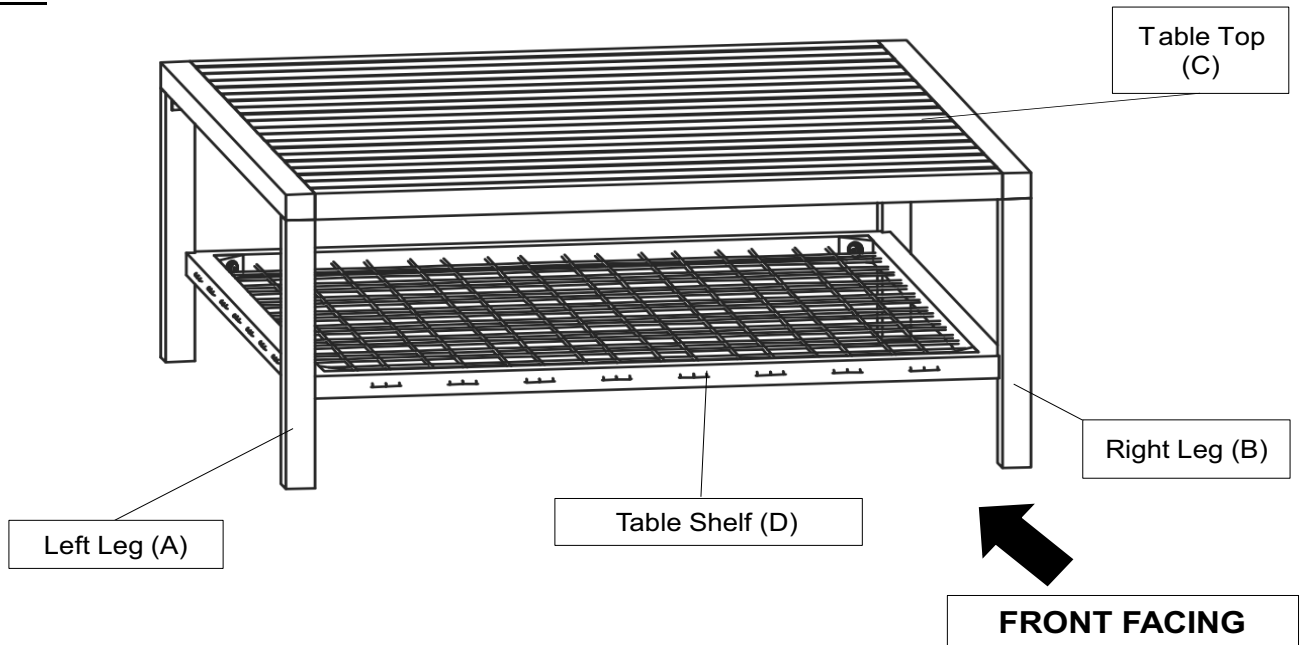

This Table has multiple parts and may require up to 15 minutes to assemble. To give you an overview of the Table parts, the above picture is to help you put the various parts into perspective. Please read through the instructions below to familiarise yourself with the parts and steps before assembly.

Step 1:

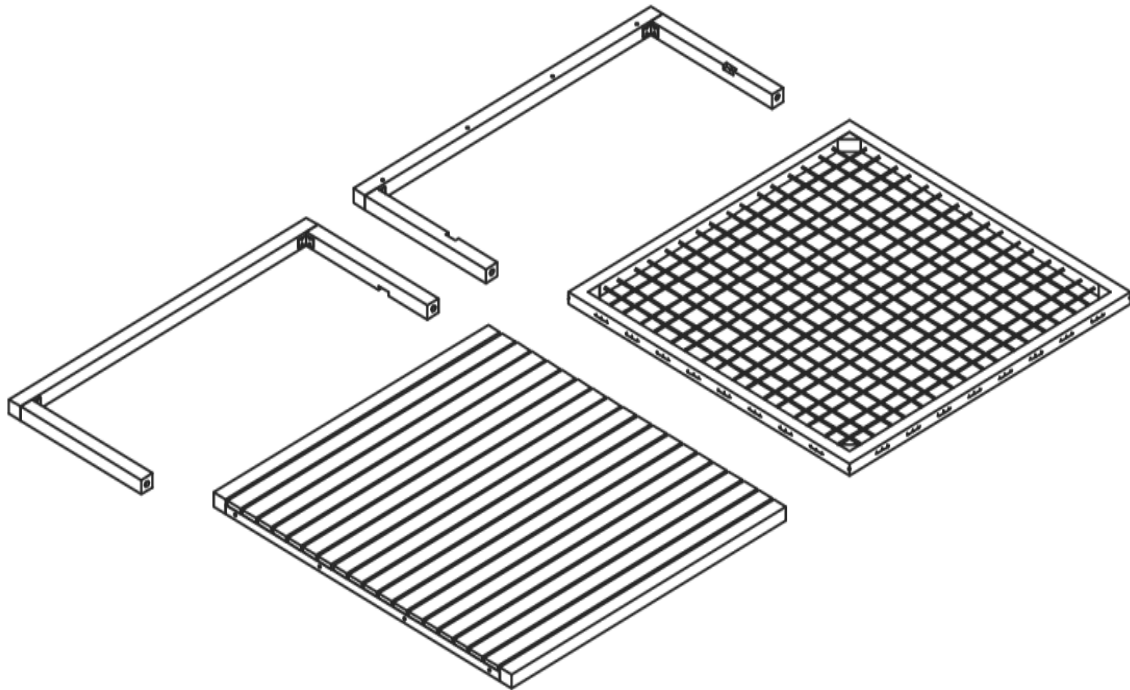

Unpack and place all parts on a clean, non-marring surface.

Step 2:

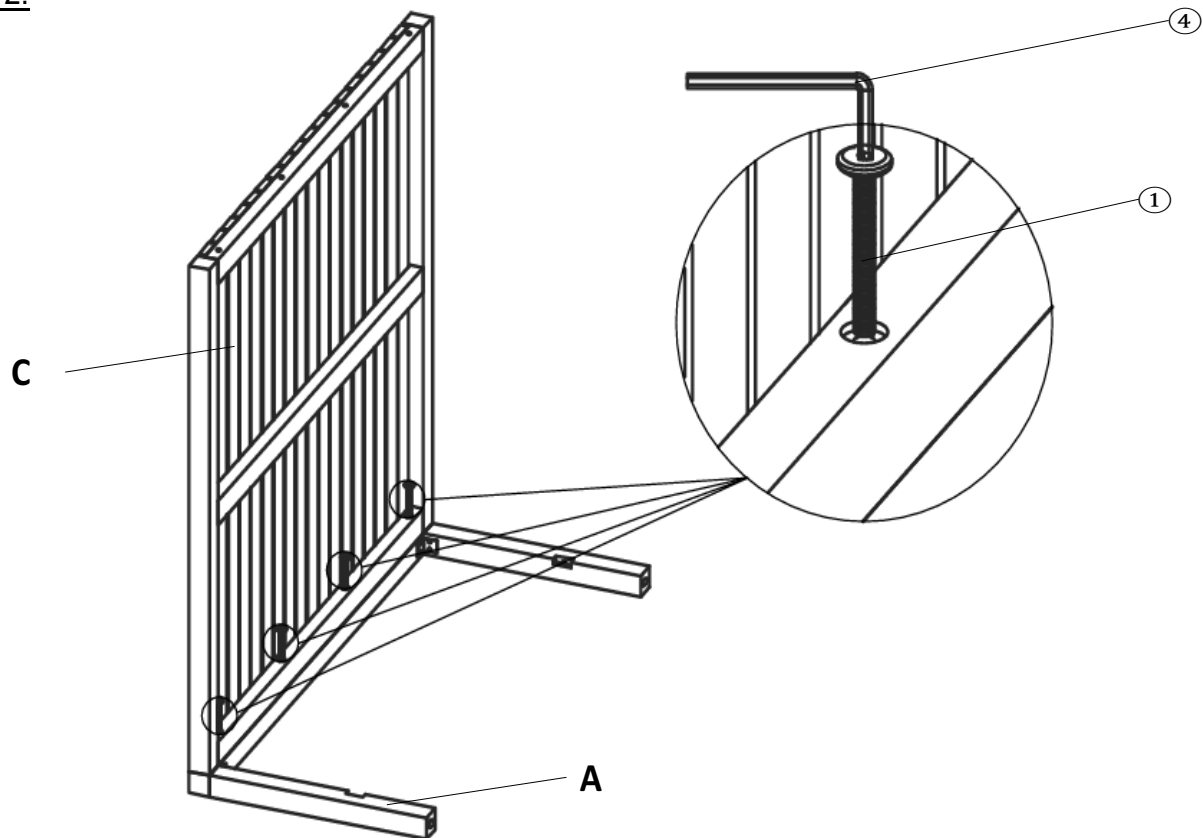

With the help of your adult partner, place Left Leg (A) facing down as shown above then attach Table Top (C) to Left Leg (A) and secure by using Bolts (1) with Allen Wrench (4).

Do not fully tighten the Bolts.

Step 3:

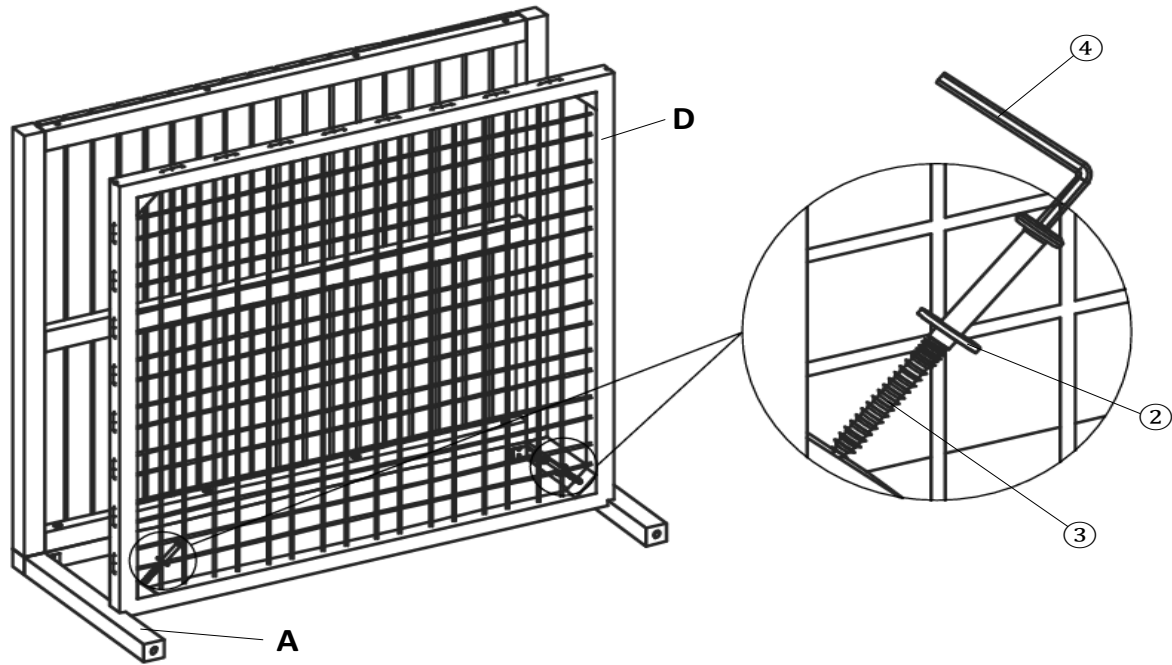

With the help of your adult partner, place the Table Shelf (D) to the assembled part in Step 2 as shown above then secure Table Shelf (D) to Left Leg (A) by using Screws (3), Flat Washers (2) and Allen Wrench (4).

Do not fully tighten the Screws.

Step 4:

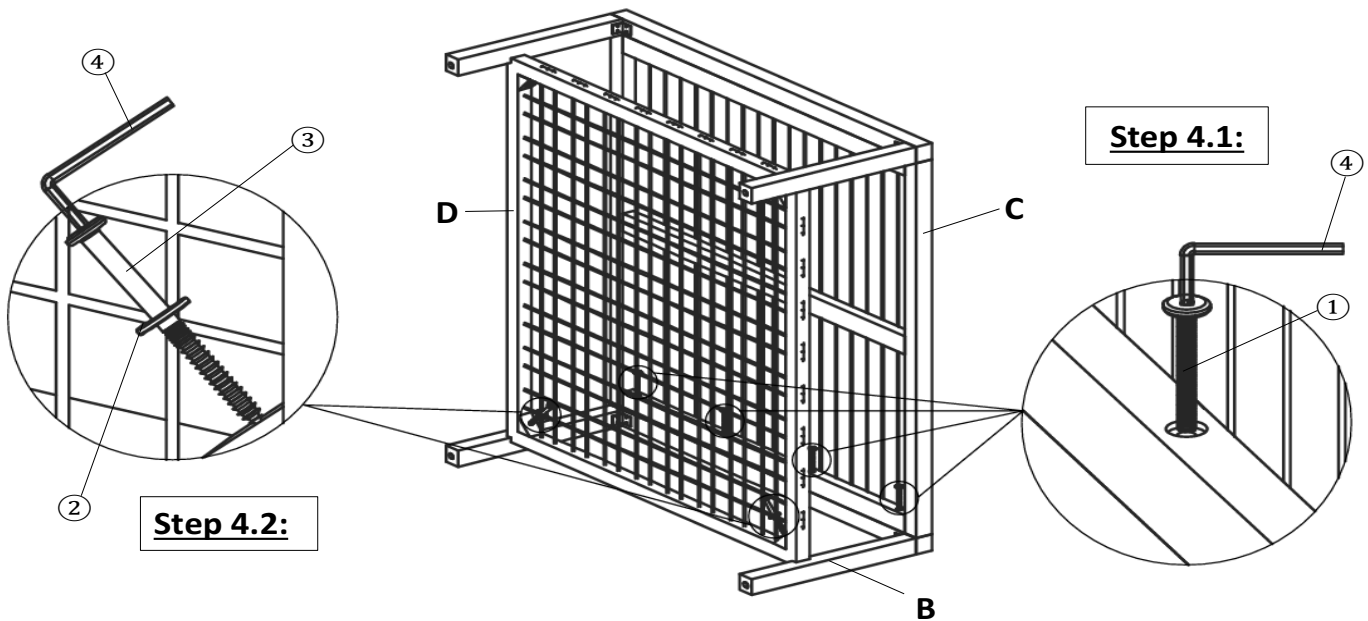

With the help of your adult partner, attach Right Leg (B) to the assembled part in Step 3, then:

Step 4.1, secure Right Leg (B) to Table Top (C) by using Bolts (1) and Allen Wrench (4) as shown above.

Step 4.2, secure Right Leg (B) to Table Shelf (D) by using Screws (3), Flat Washers (2) and Allen Wrench (4) as shown above.

Do not fully tighten the Bolts and Screws.

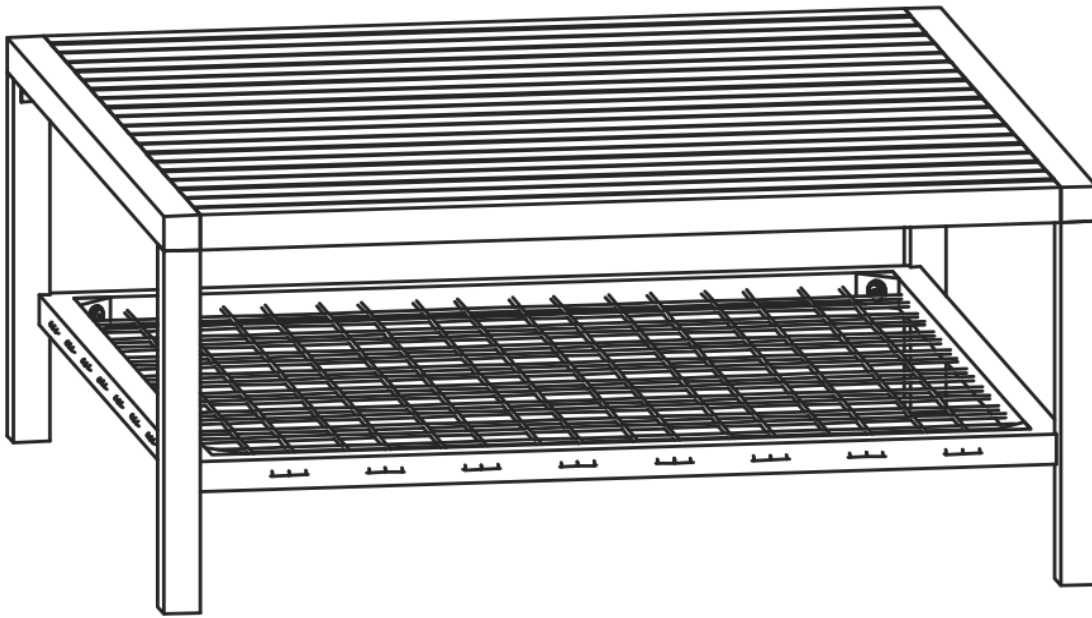

With the help of your adult partner, stand the Table up.
Exert pressure floorwards, onto the Table with both your hands.
This pressure will help the Legs and Table Top reach full alignment status.
Check for wobbles on a LEVEL surface.
If no wobbles are found proceed to tighten the Bolts and Screws in a sequential manner, until evenly secured.
When tightening the Bolts and Screws tighten sequentially.
Do not tighten any Bolt and Screw fully and then move on towards the next one.
If there are still wobbles, loosen the Bolts, Screws and excute the same above process.
WARNING!! IF TABLE IS NOT STABLE, IT COULD LEAD TO DAMAGING THE PRODUCT.
Your Table is ready for use.
This Table can only be used on a flat, level surface.