

- ⓓ Montageanleitung
- Ⓝ Handleiding voor de montage
- Ⓣ Montaj talimati
- ⓕ Notice de montage
- Ⓒ Montážni návod
- ⓗ Szerelési útmutató
- ⓖ Assembly instructions
- Ⓟ Instrukcja montażu
- Ⓡ Инструкция по монтажу
- ⓔ Istruzioni di montaggio
- Ⓚ Návod na montáž
- ⓇO Instrucțiuni de montaj
- ⓔS Instrucciones de montaje

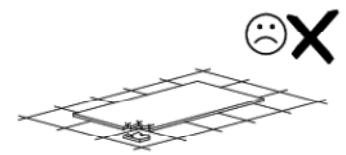

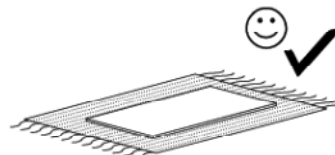

A1 x 20

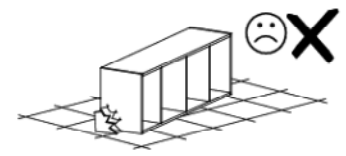
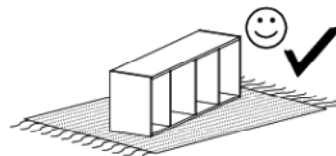
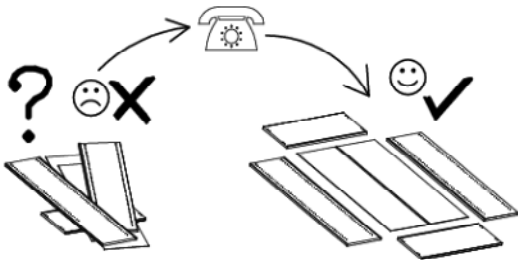
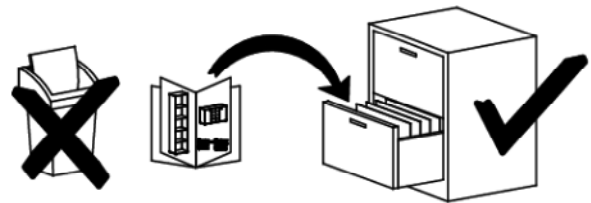
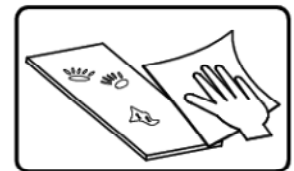
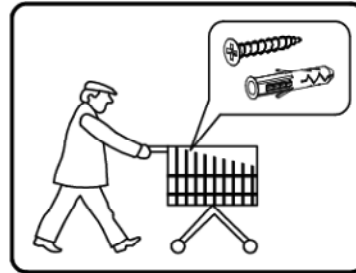
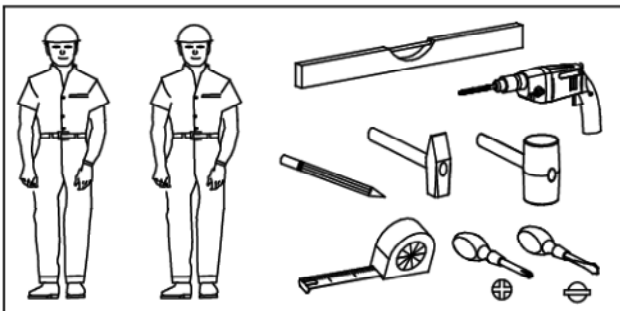
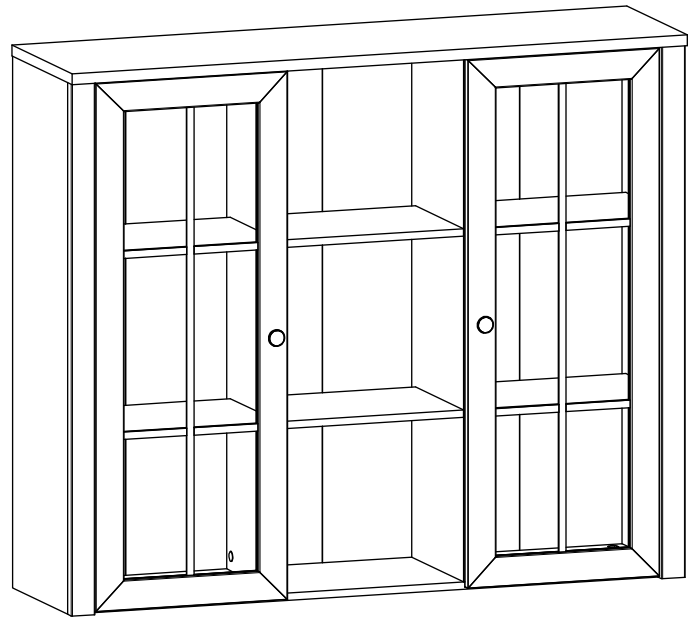
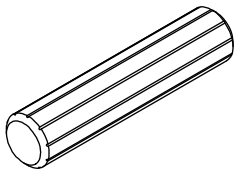

Ø8x35mm

B1 x 22

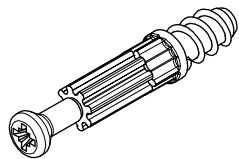

Ø5x38mm

C1 x 22

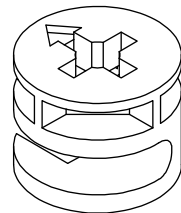

Ø15x12mm

E1 x 24

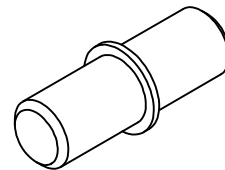

Ø5x16mm

G1 x 20

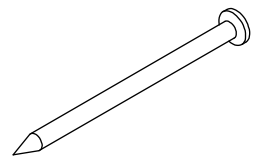

26mm

G2 x 18

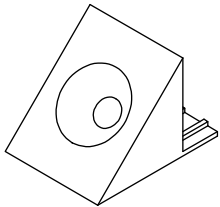

14x14mm

G3 x 20

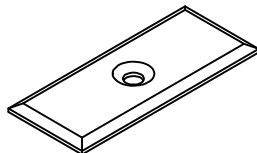

22x10mm

J11 x 22

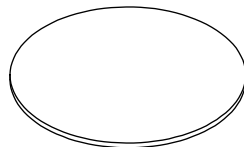

Ø21mm

T1 x 2

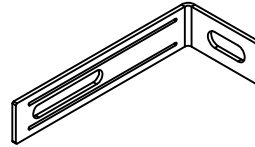

76x15mm

T3 x 2

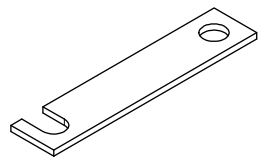

50x9mm

U2 x 2

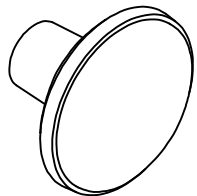

Ø33mm

W2 x 34

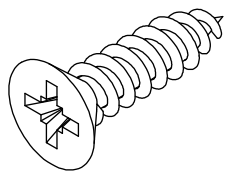

Ø3,5x16mm

X4 x 2

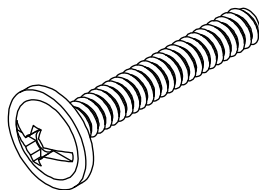

M4x25mm

Y1 x 4

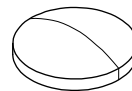

Ø8mm

Z6 x 4

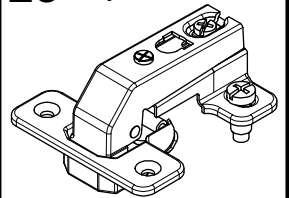

Ø35mm, 90°

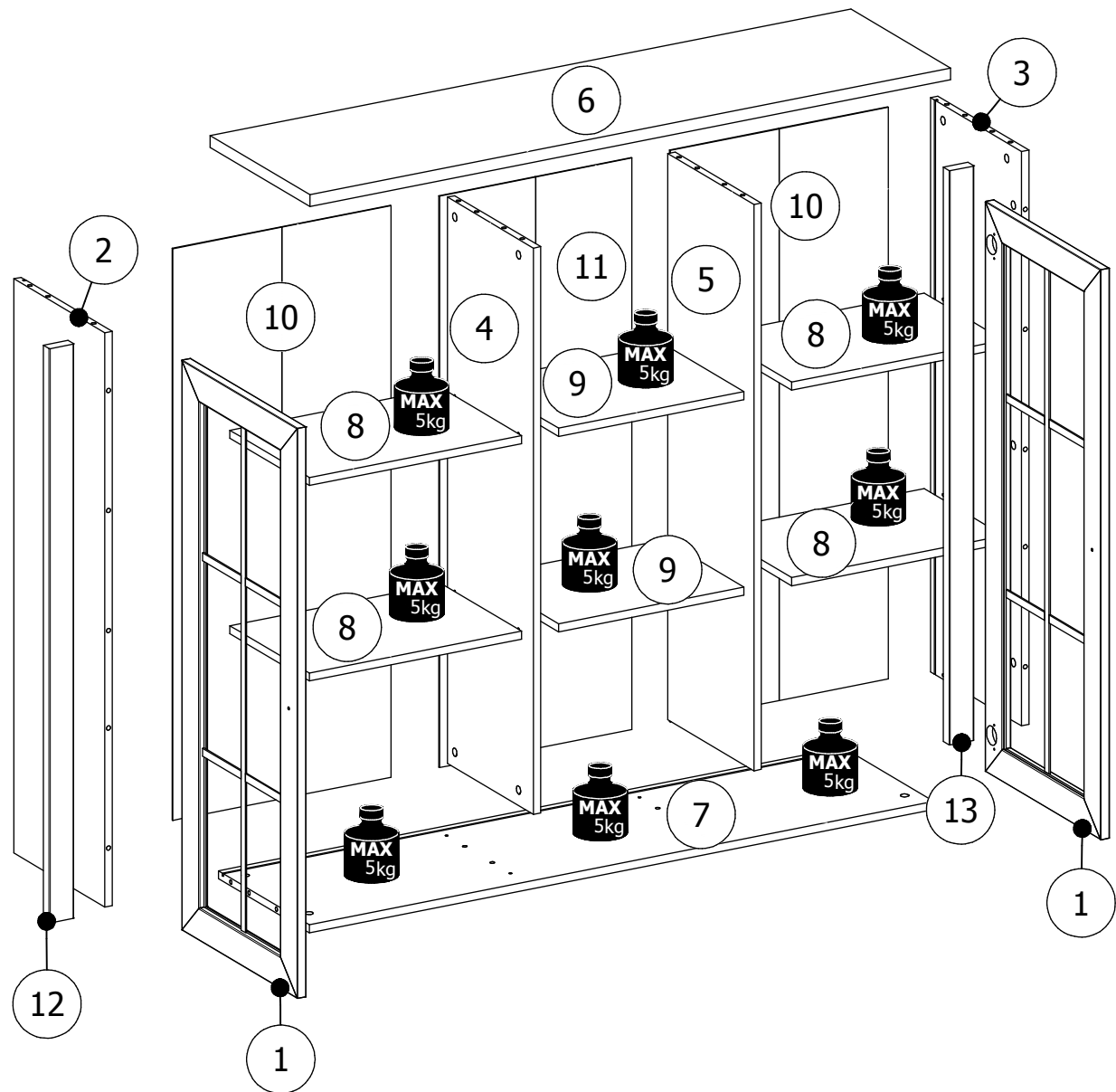

nr	L[mm]	B[mm]	T[mm]	Menge	Colli
1	1064	405	18	2	3/3
2	1072	320	15	1	1/3
3	1072	320	15	1	1/3
4	1057	302	15	1	2/3
5	1057	302	15	1	2/3
6	1299	350	22	1	2/3
7	1266	320	15	1	2/3
8	430	280	15	4	1/3
9	376	280	15	2	1/3
10	1067	442	2,5	2	2/3
11	1067	390	2,5	1	2/3
12	1072	50	22	1	1/3
13	1072	50	22	1	1/3

1

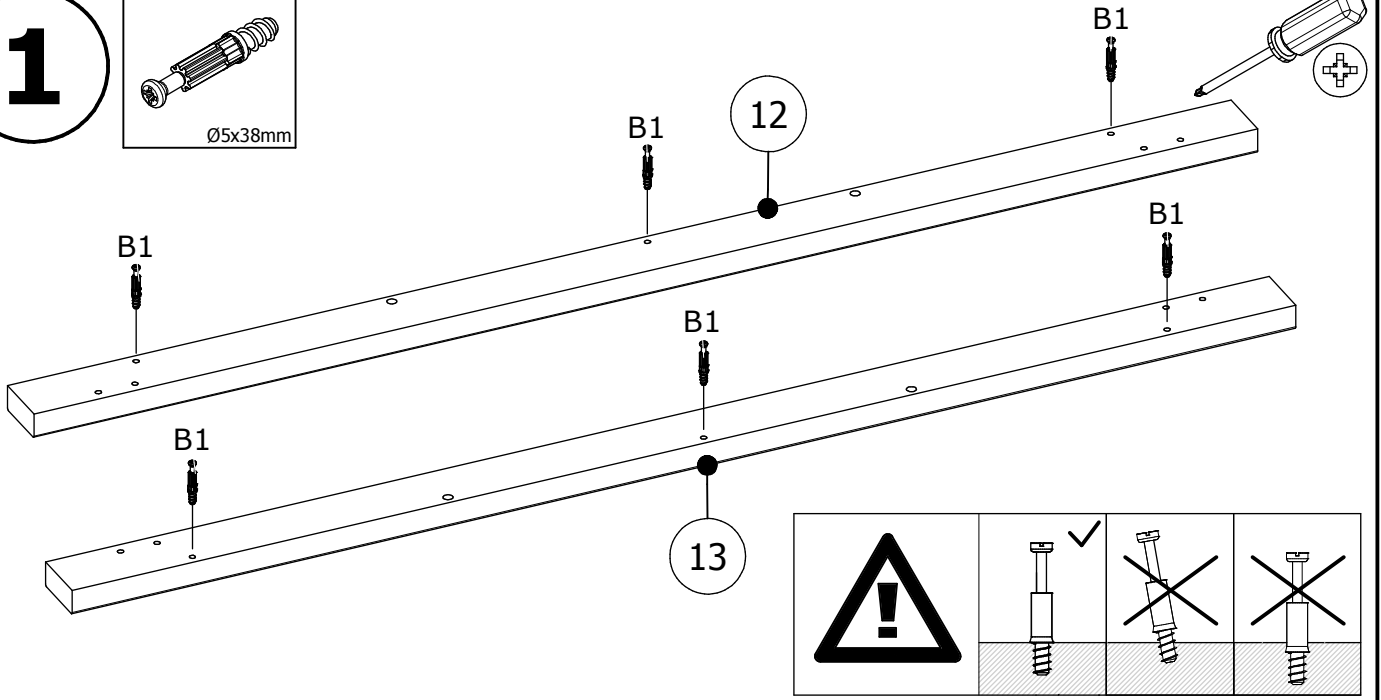
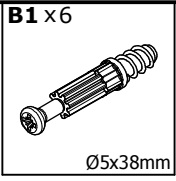

2

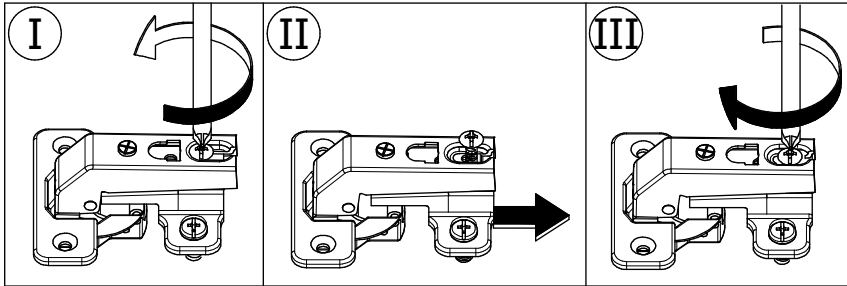
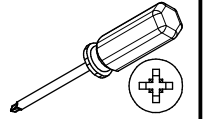
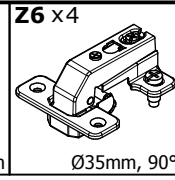
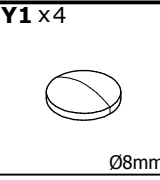
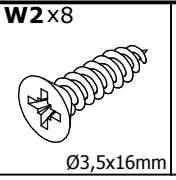

x2

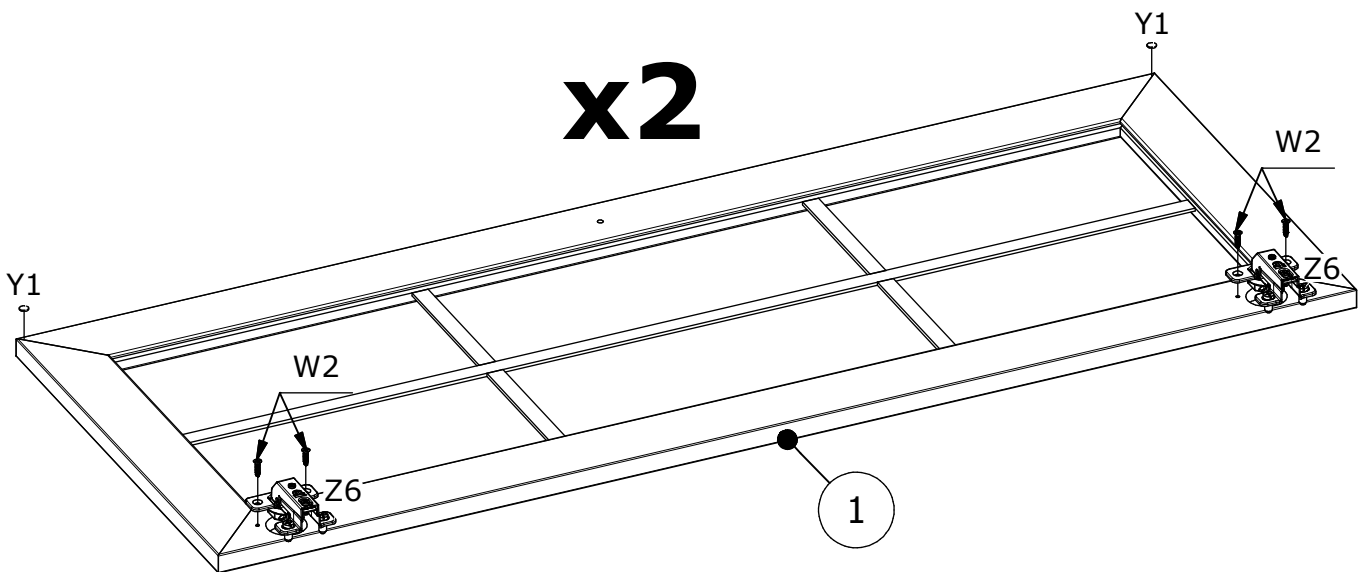

3

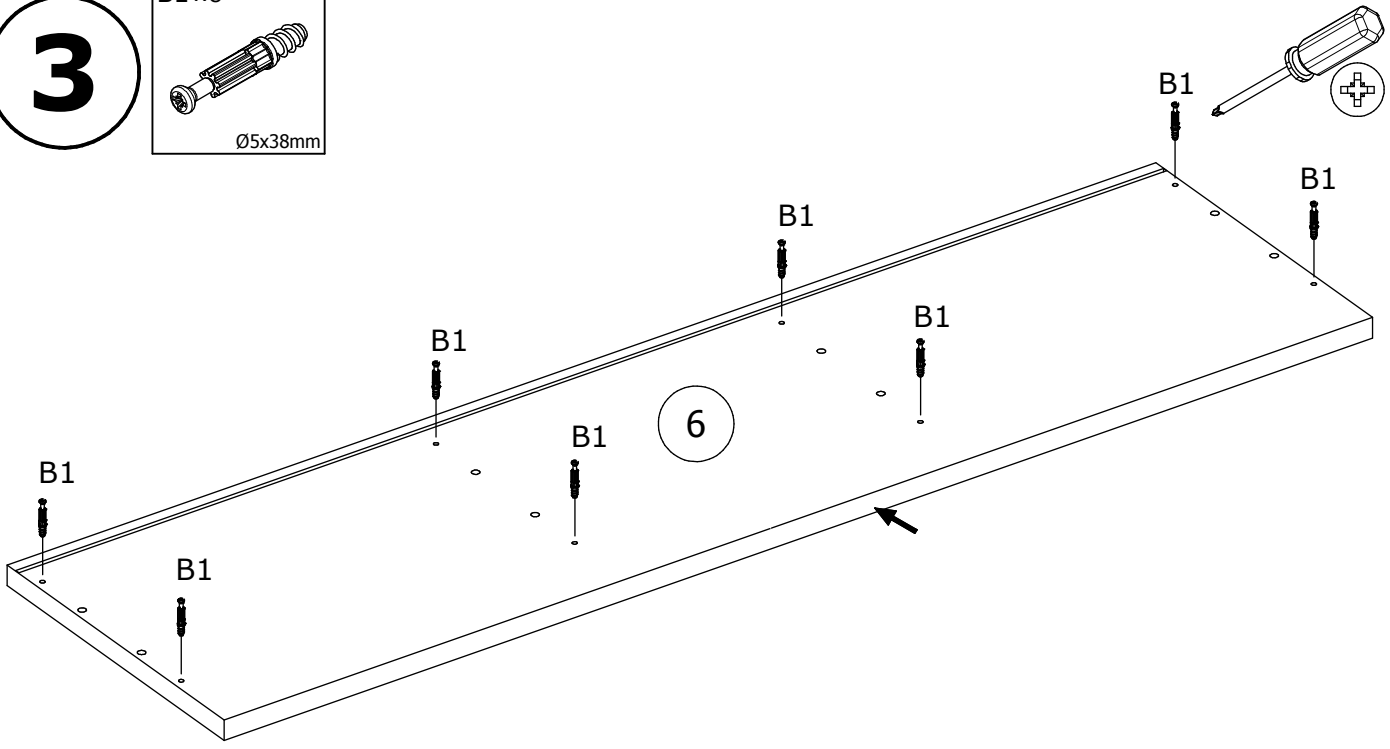
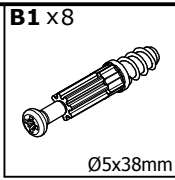

4

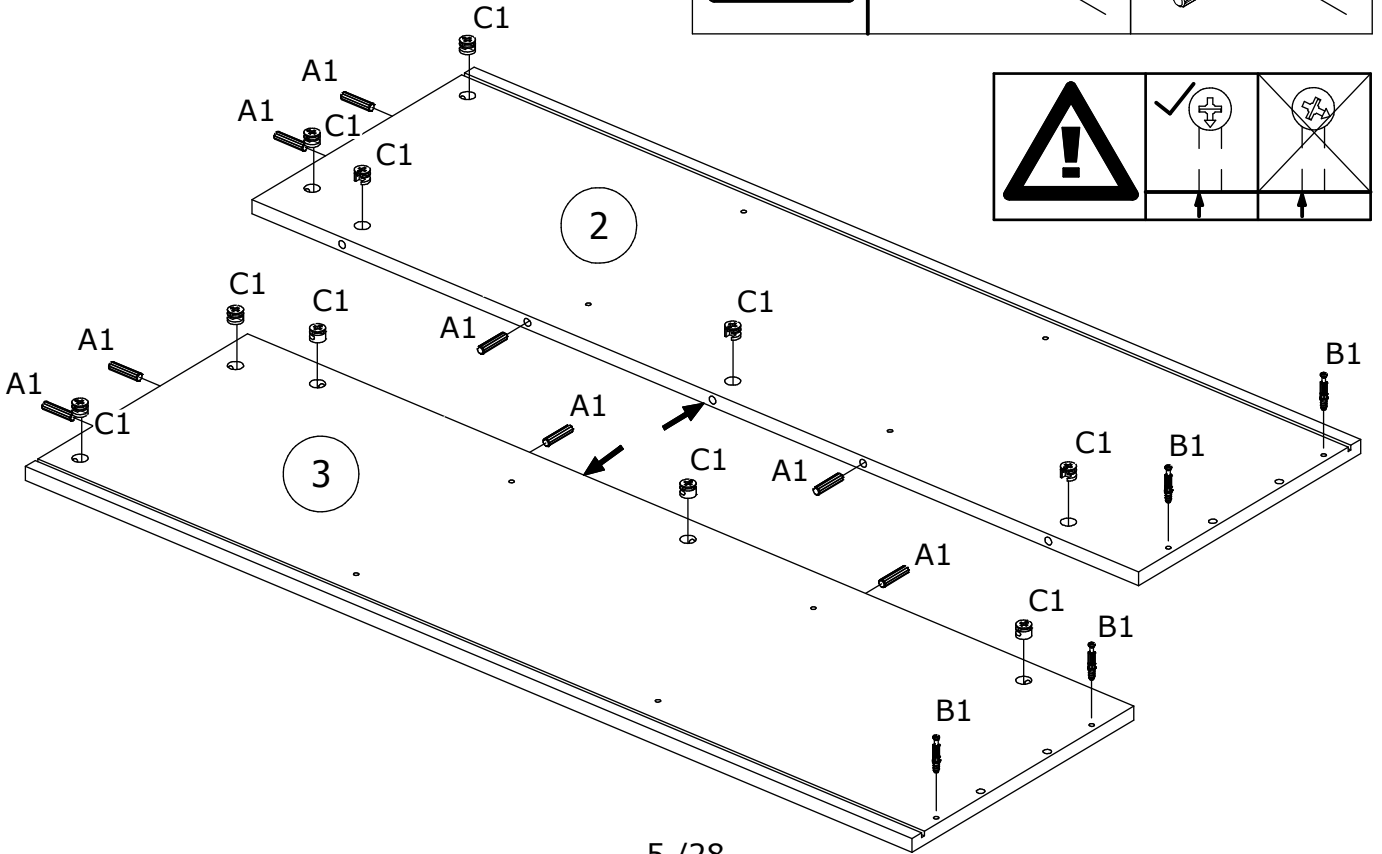
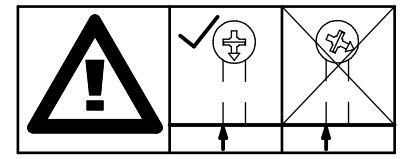
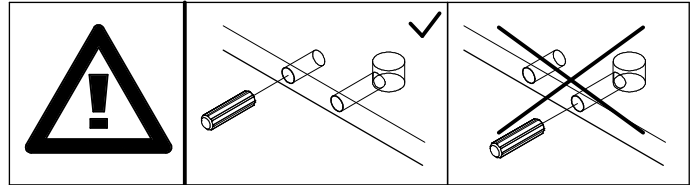
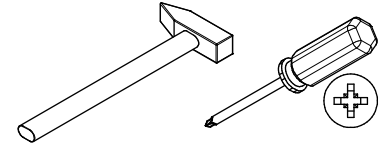
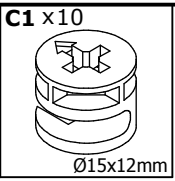
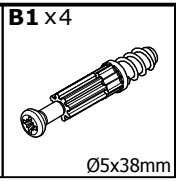
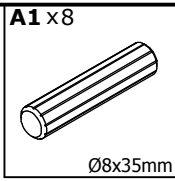

5

A1 x 8

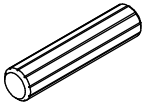

Ø8x35mm

C1 x 8

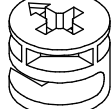

Ø15x12mm

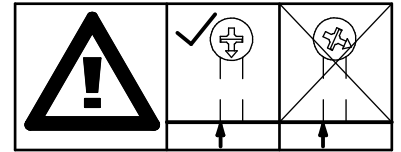
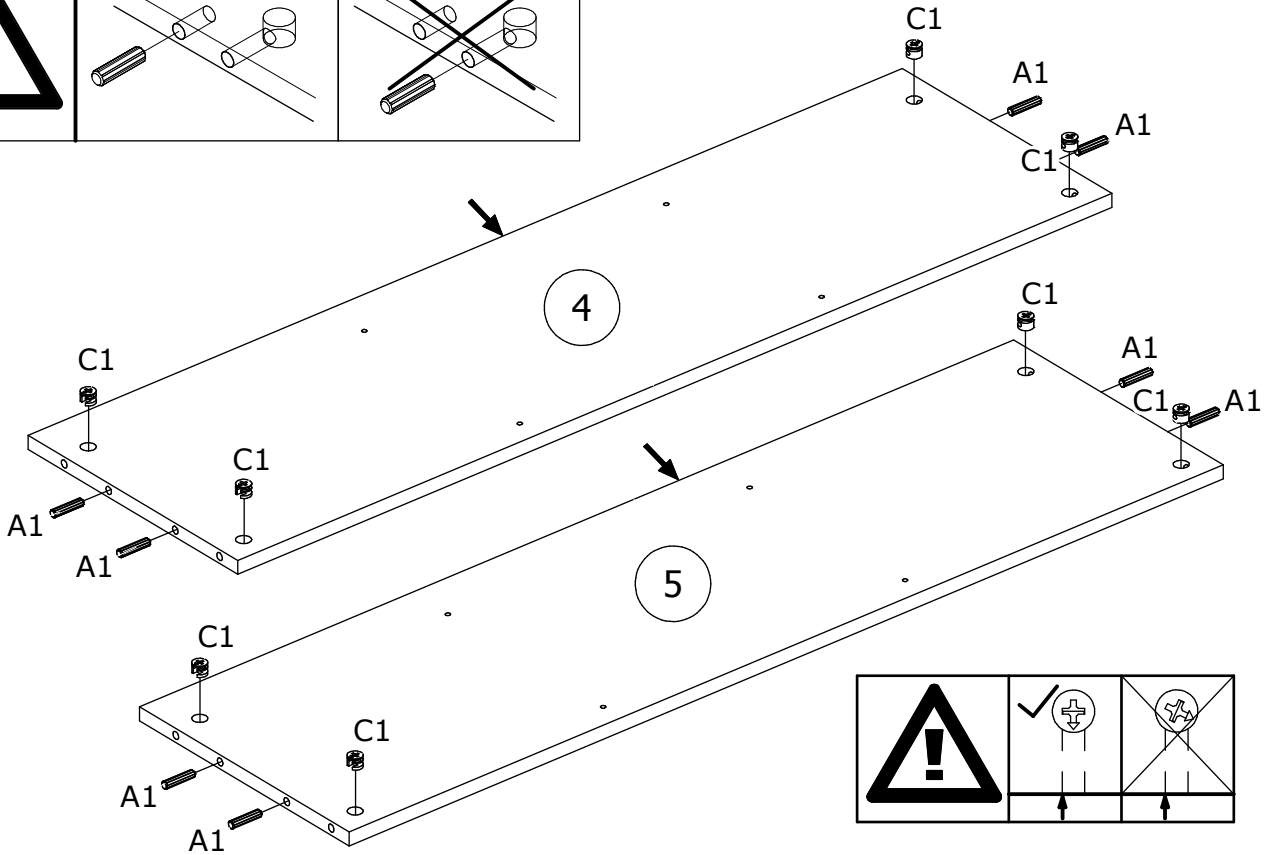
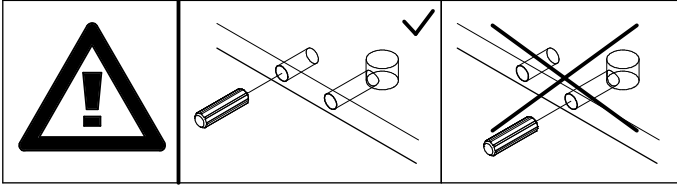
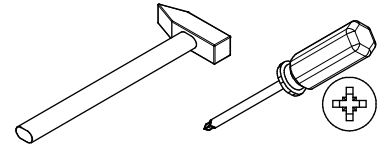

6

A1 x 4

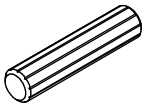

Ø8x35mm

B1 x 4



Ø5x38mm

C1 x 4

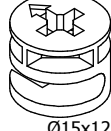

Ø15x12mm

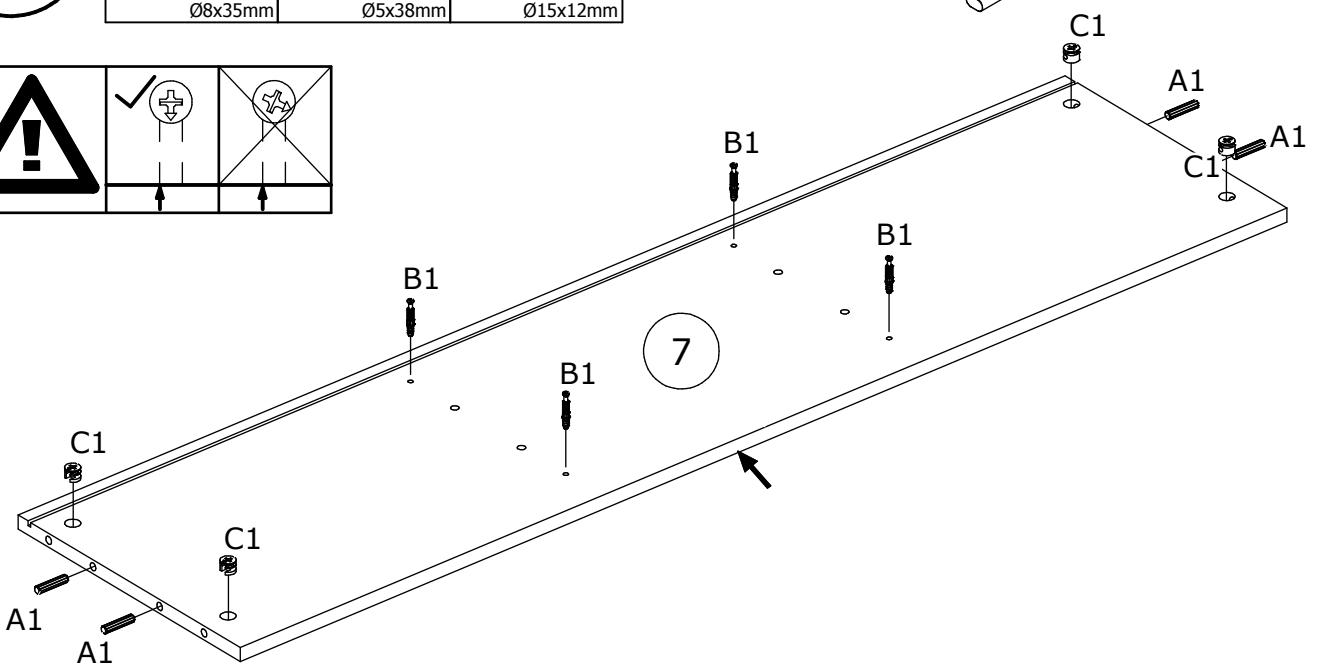
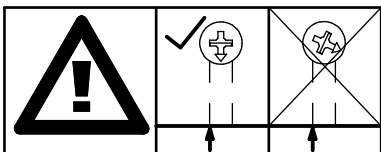
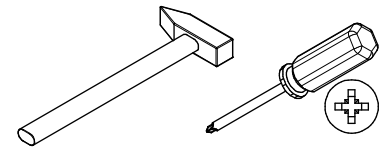

7

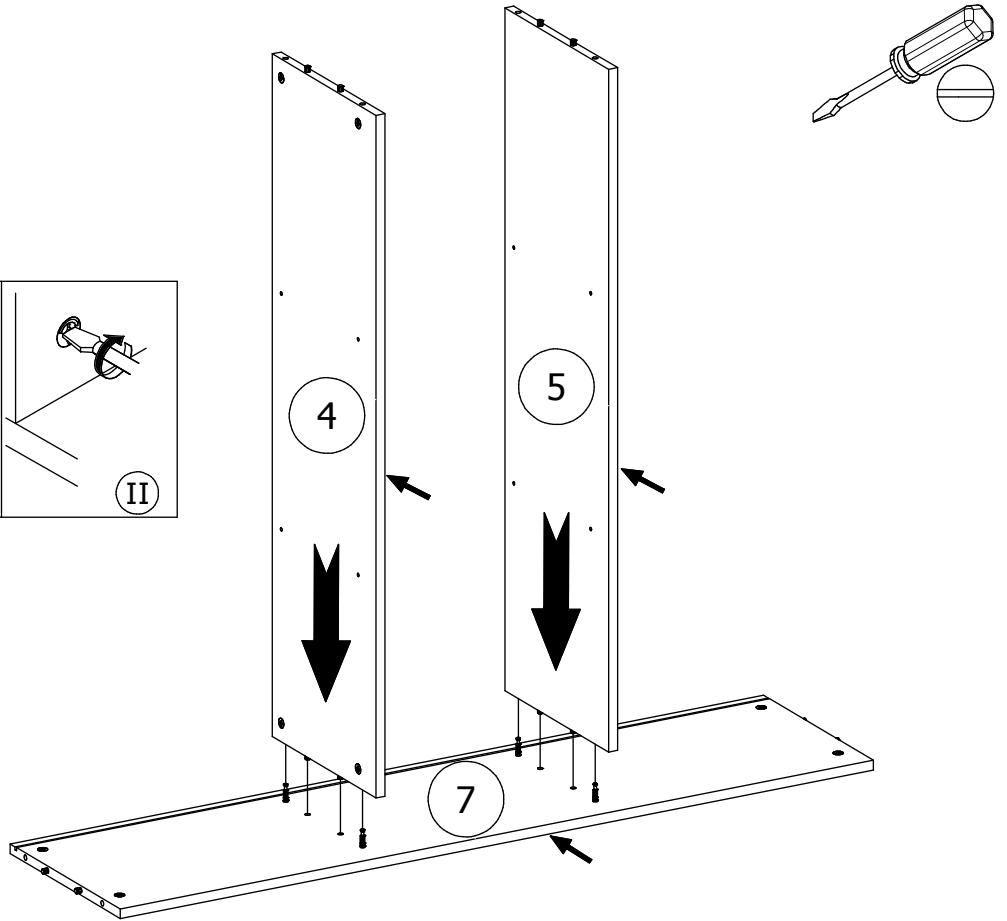
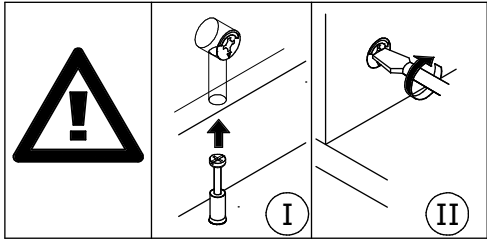

8

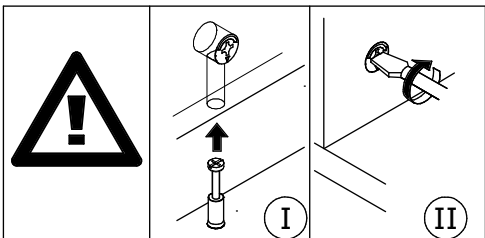
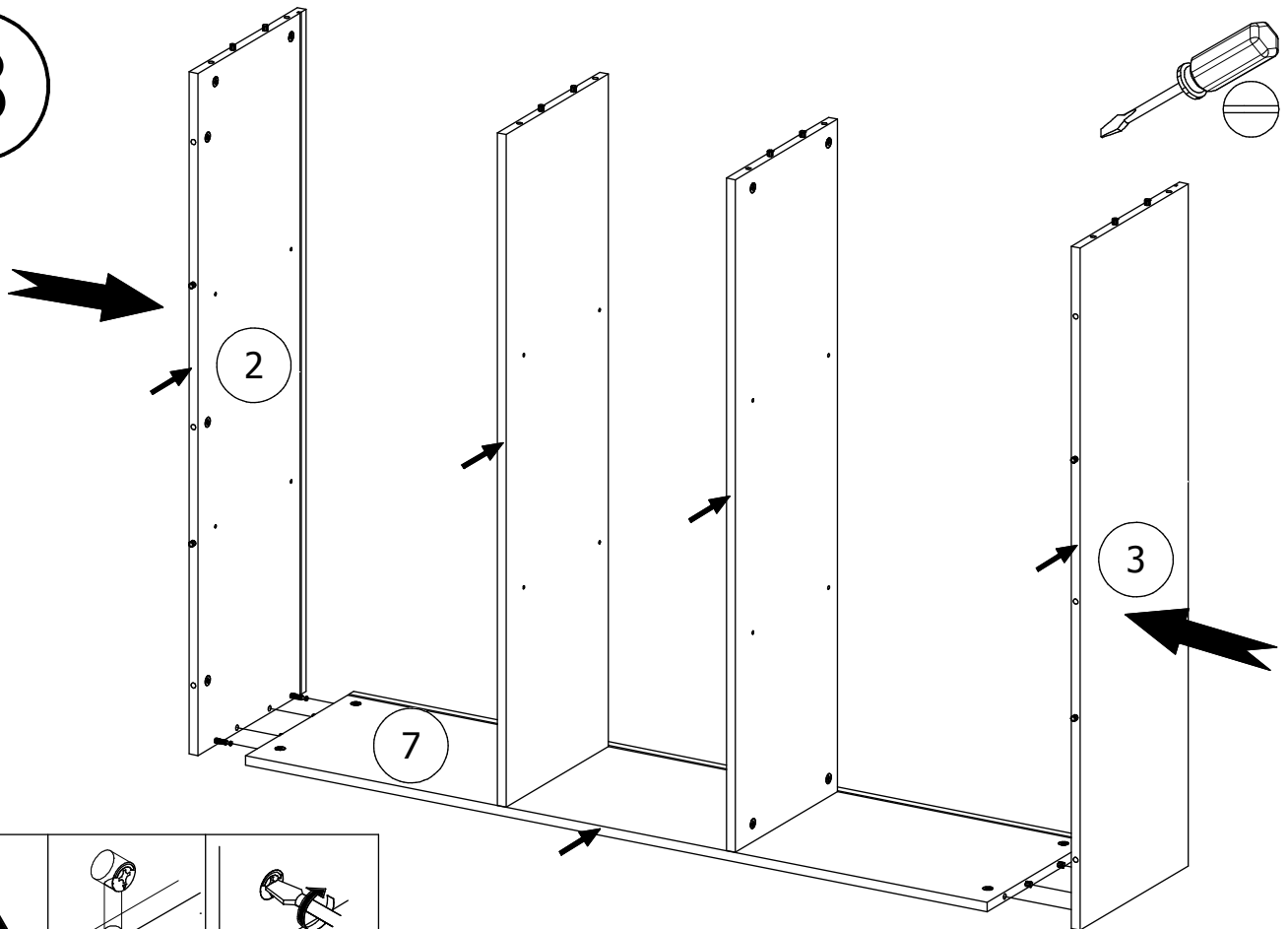

9

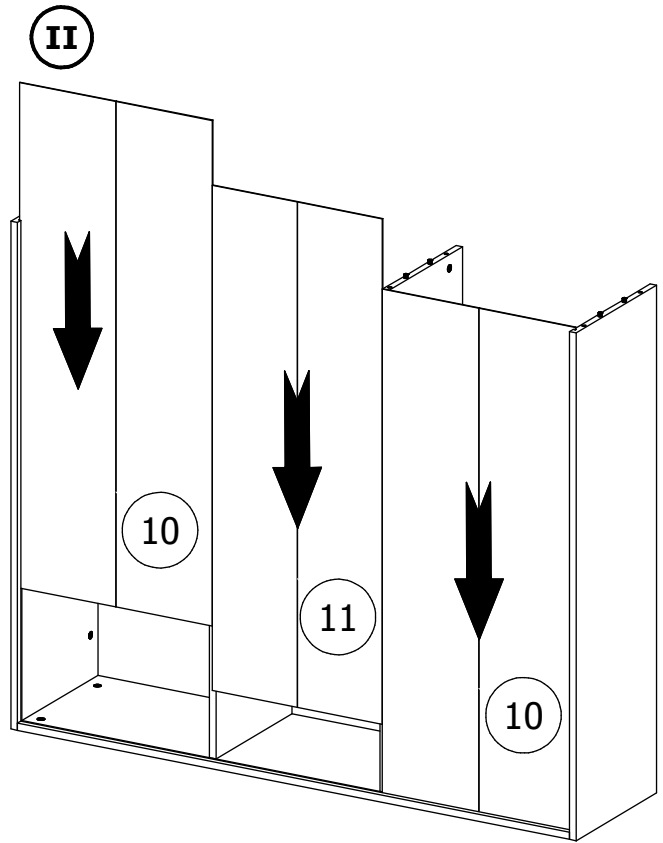
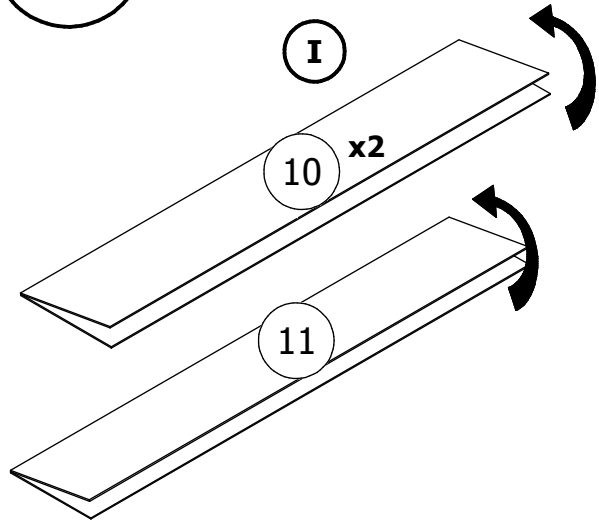

10

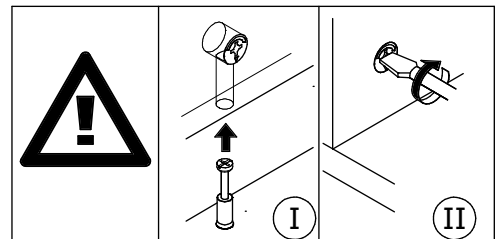
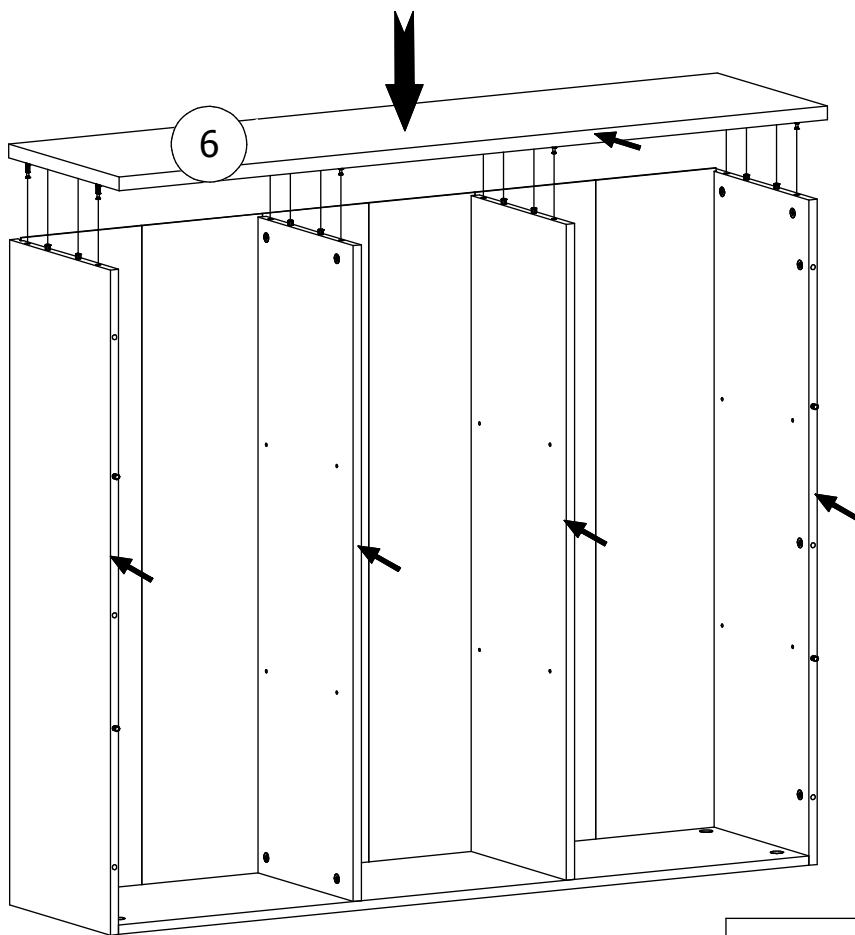

11

G1 x 20

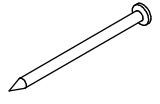

26mm

G3 x 20

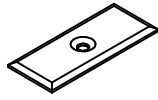

22x10mm

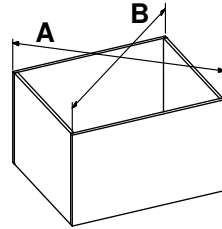
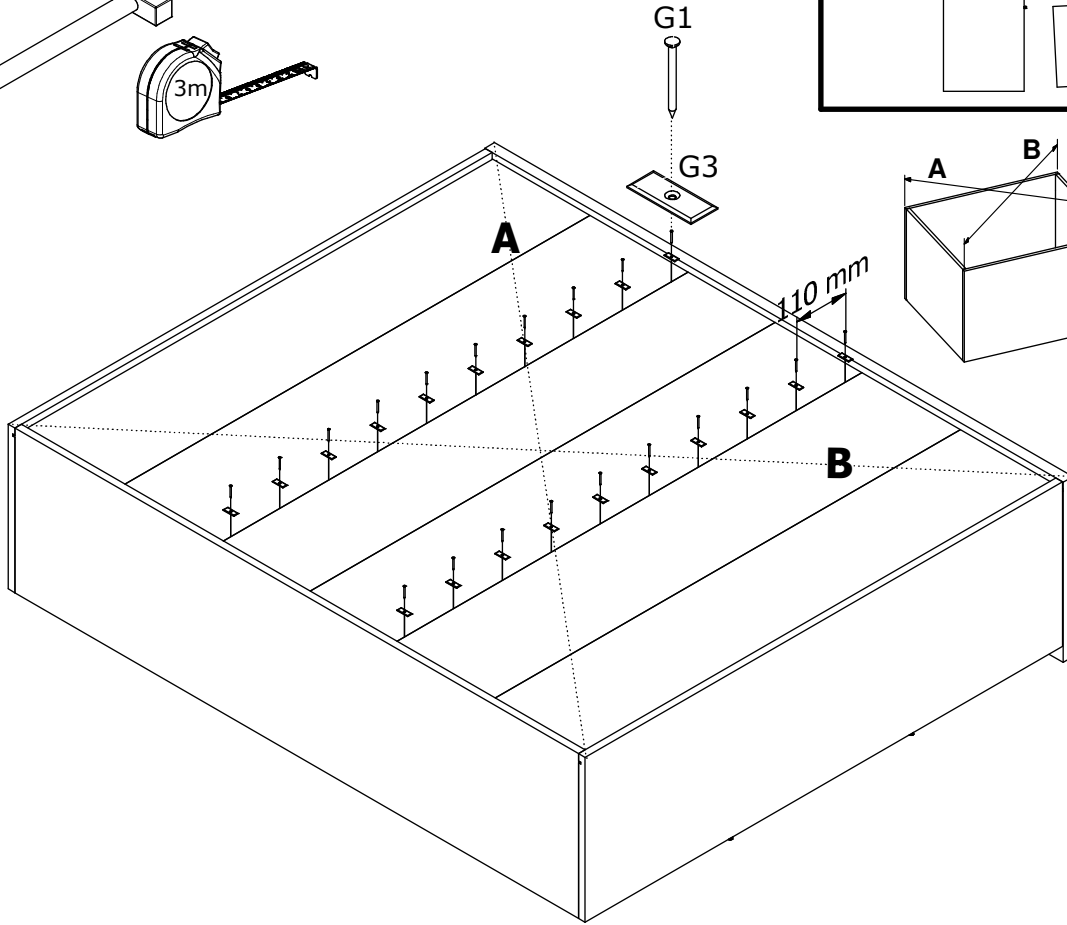
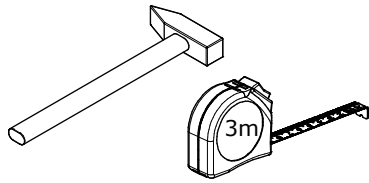
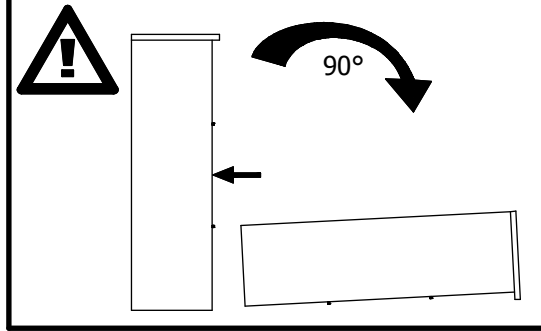

A=B



12

G2 x 18

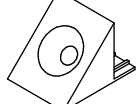

14x14mm

W2 x 18

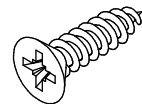

Ø3,5x16mm

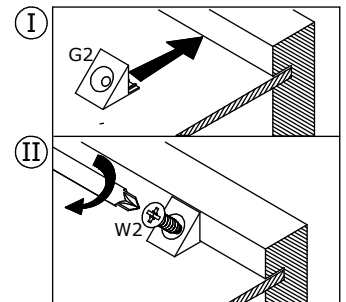
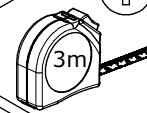
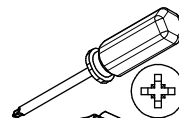
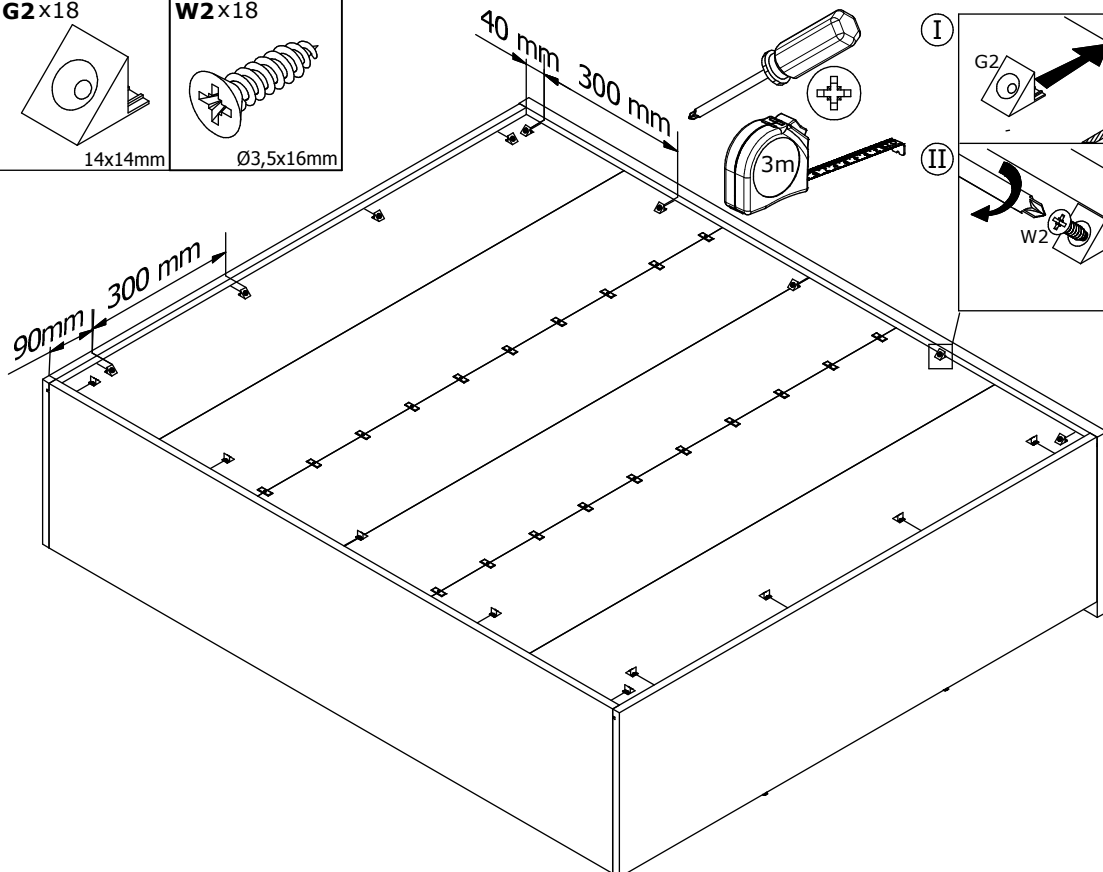

13

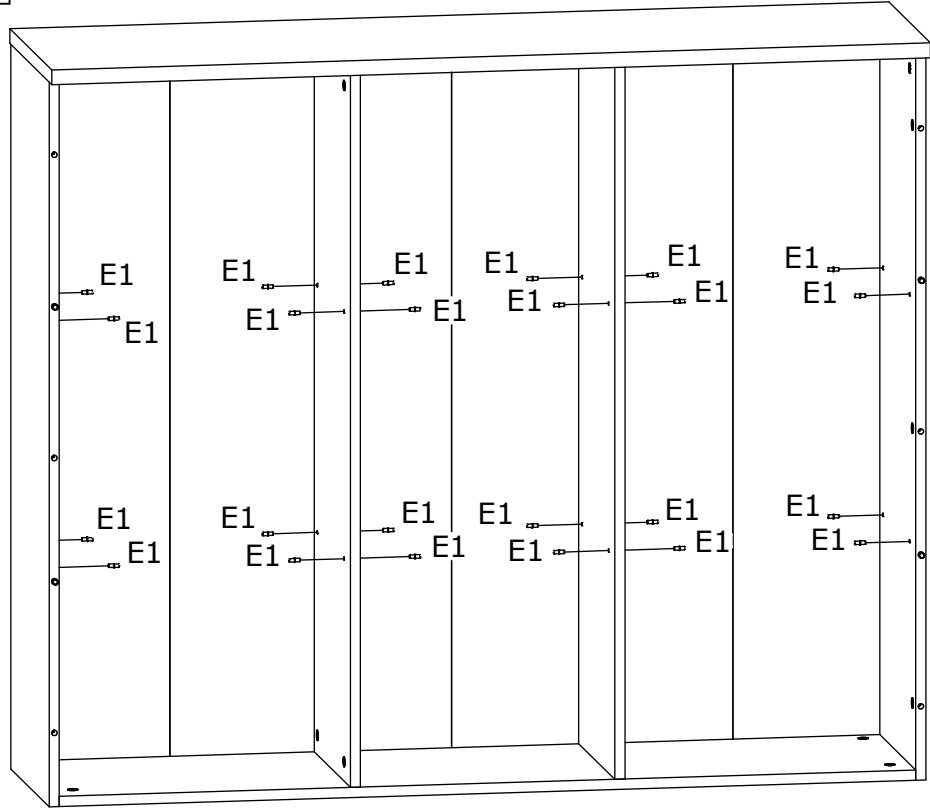
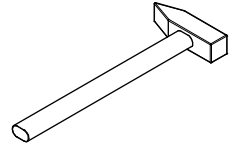
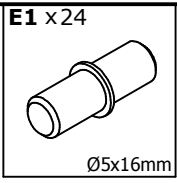

14

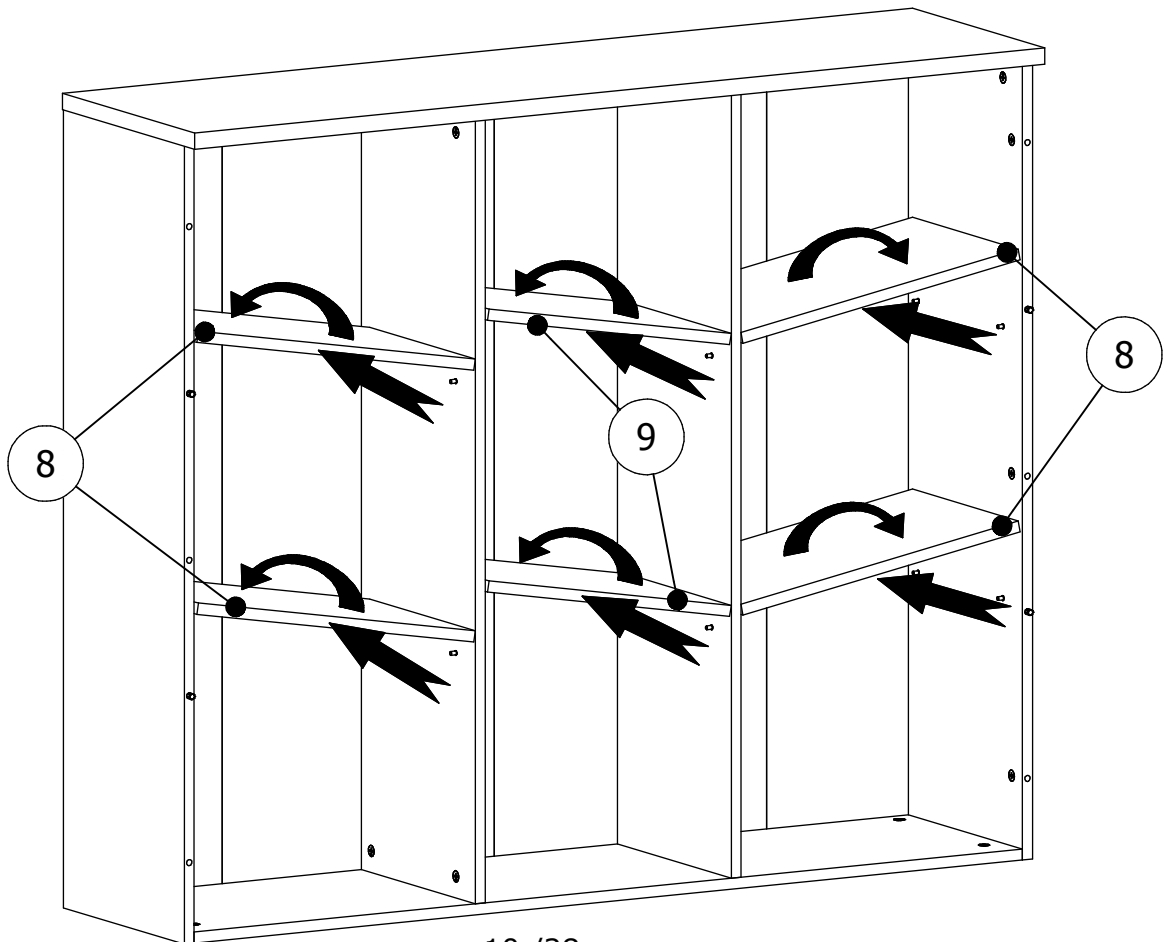

15

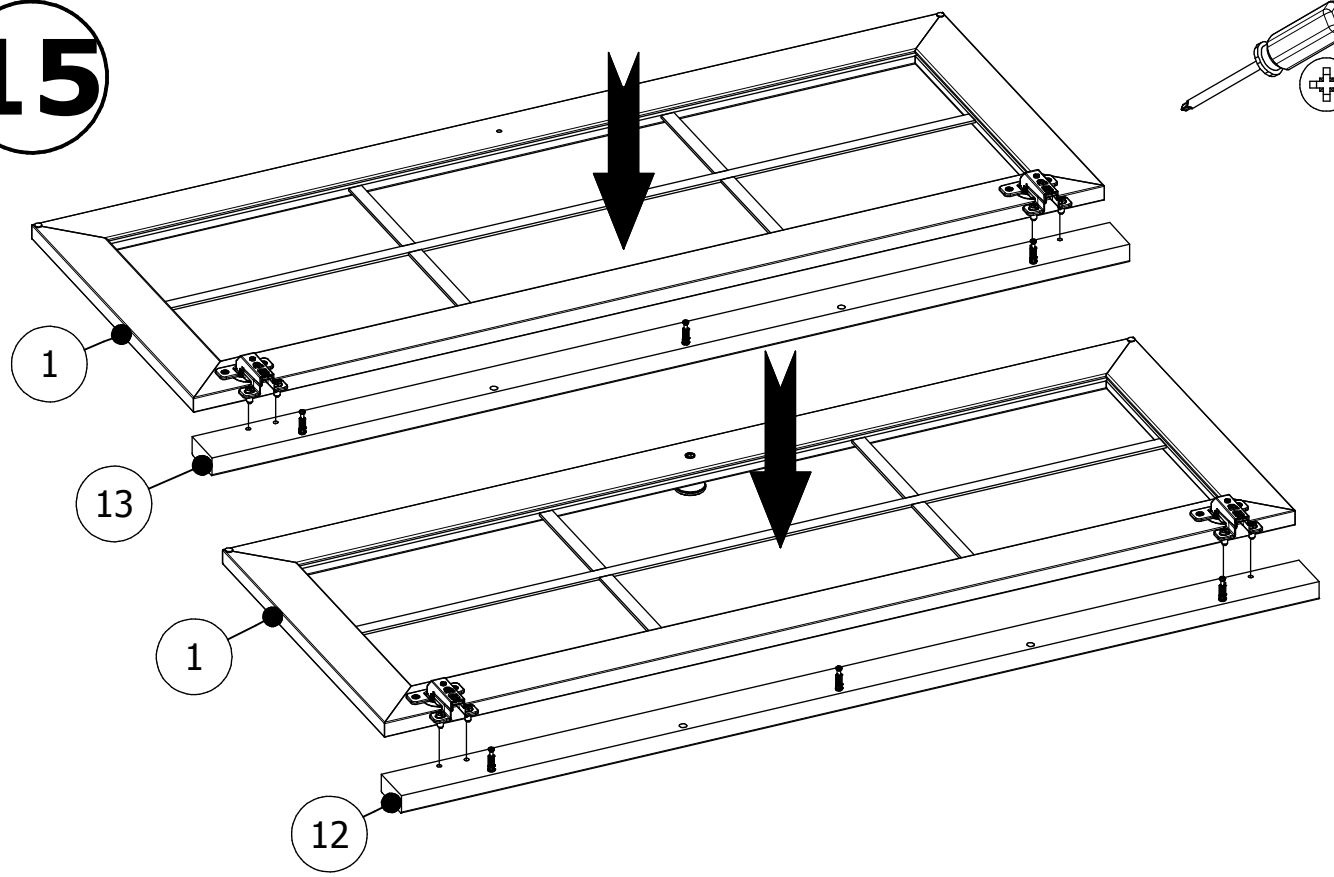
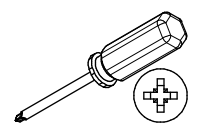

16

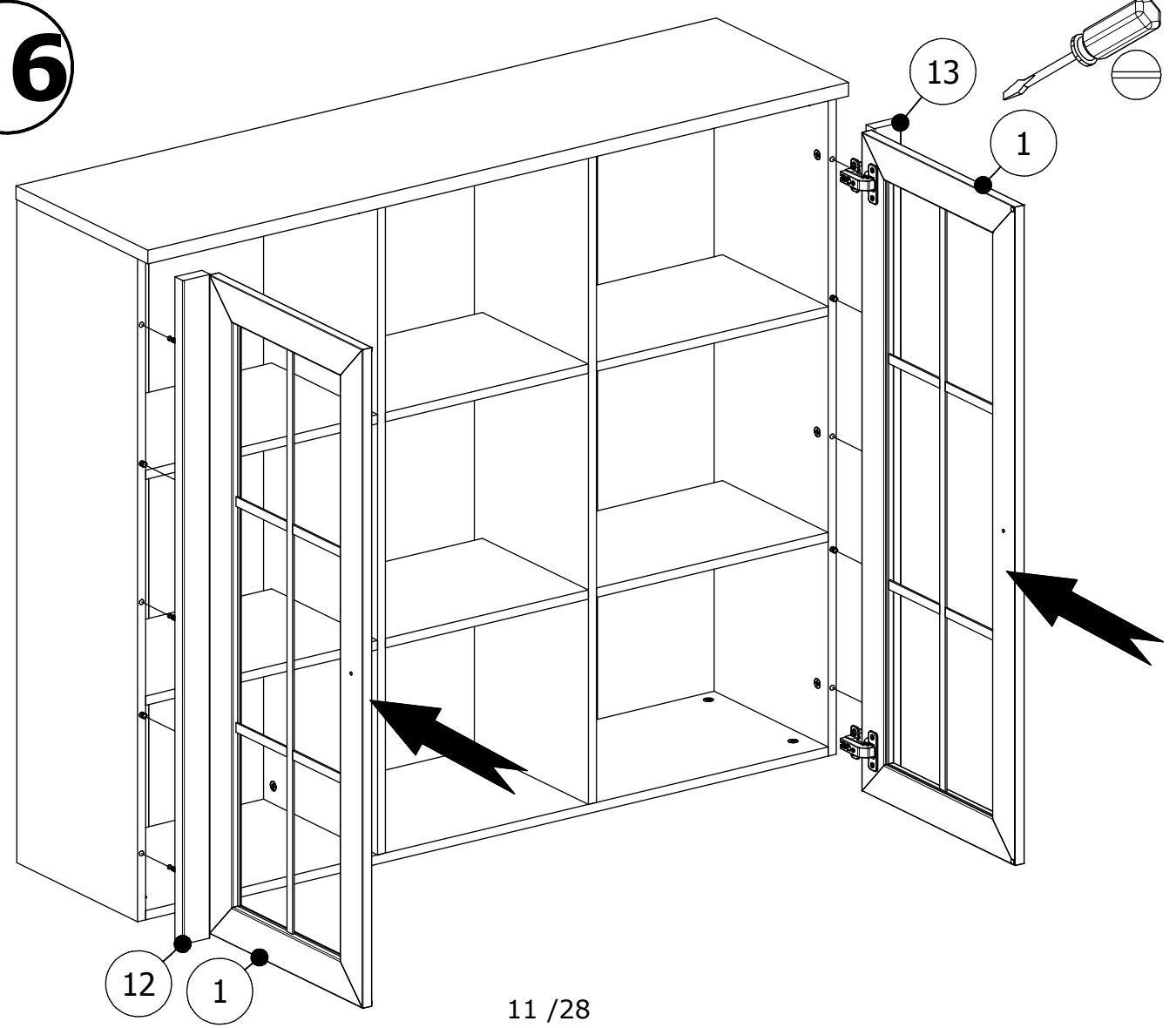
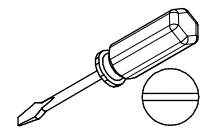

17

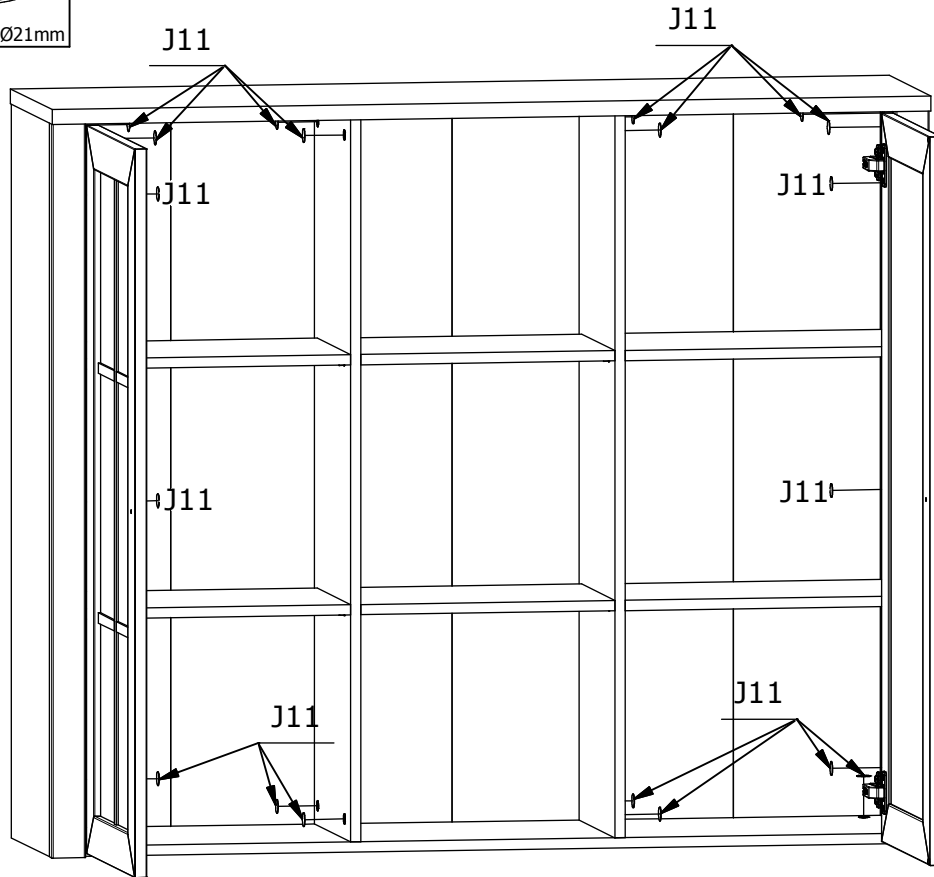
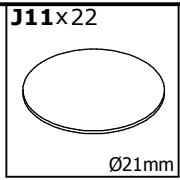

18

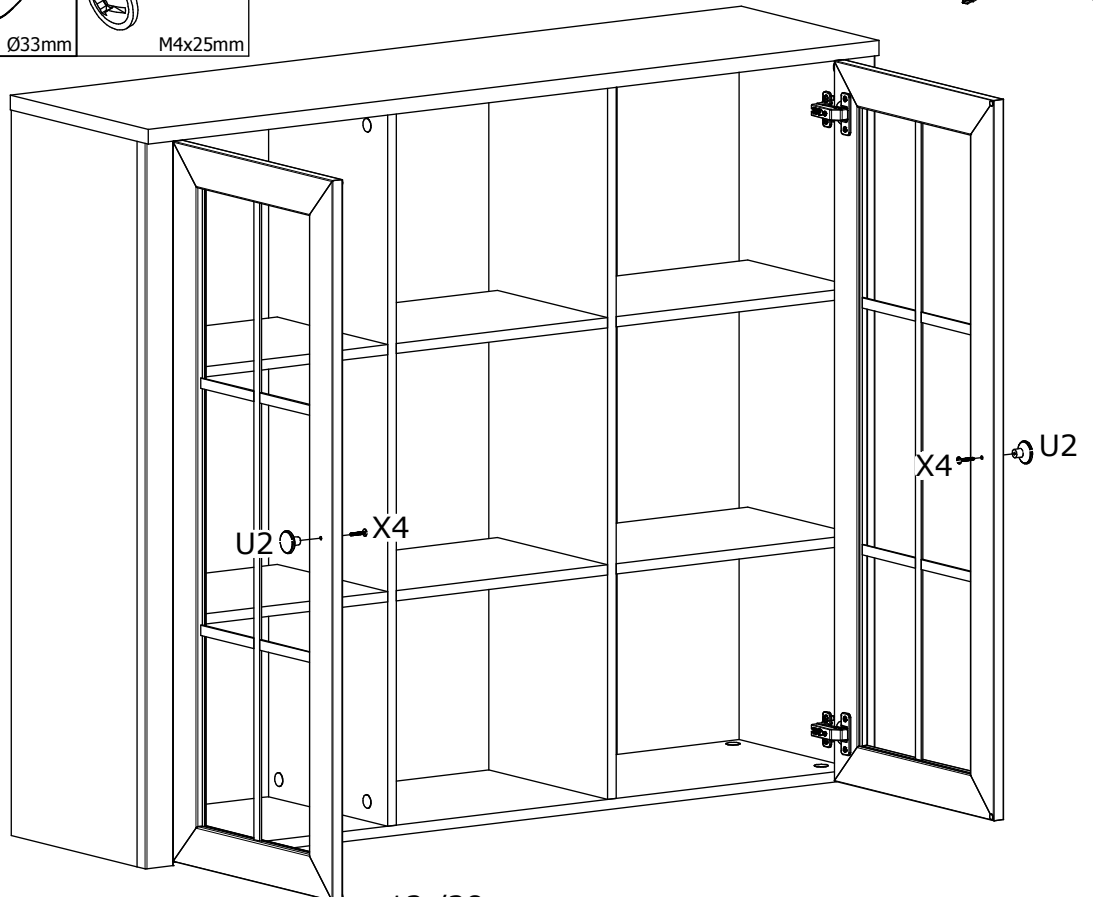
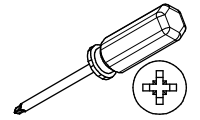
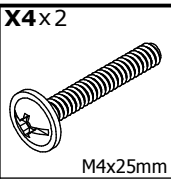
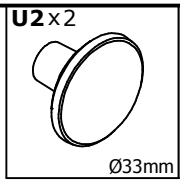

19

T3 x2

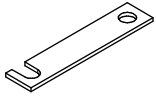

50x9mm

W2 x4

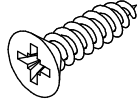

Ø3,5x16mm

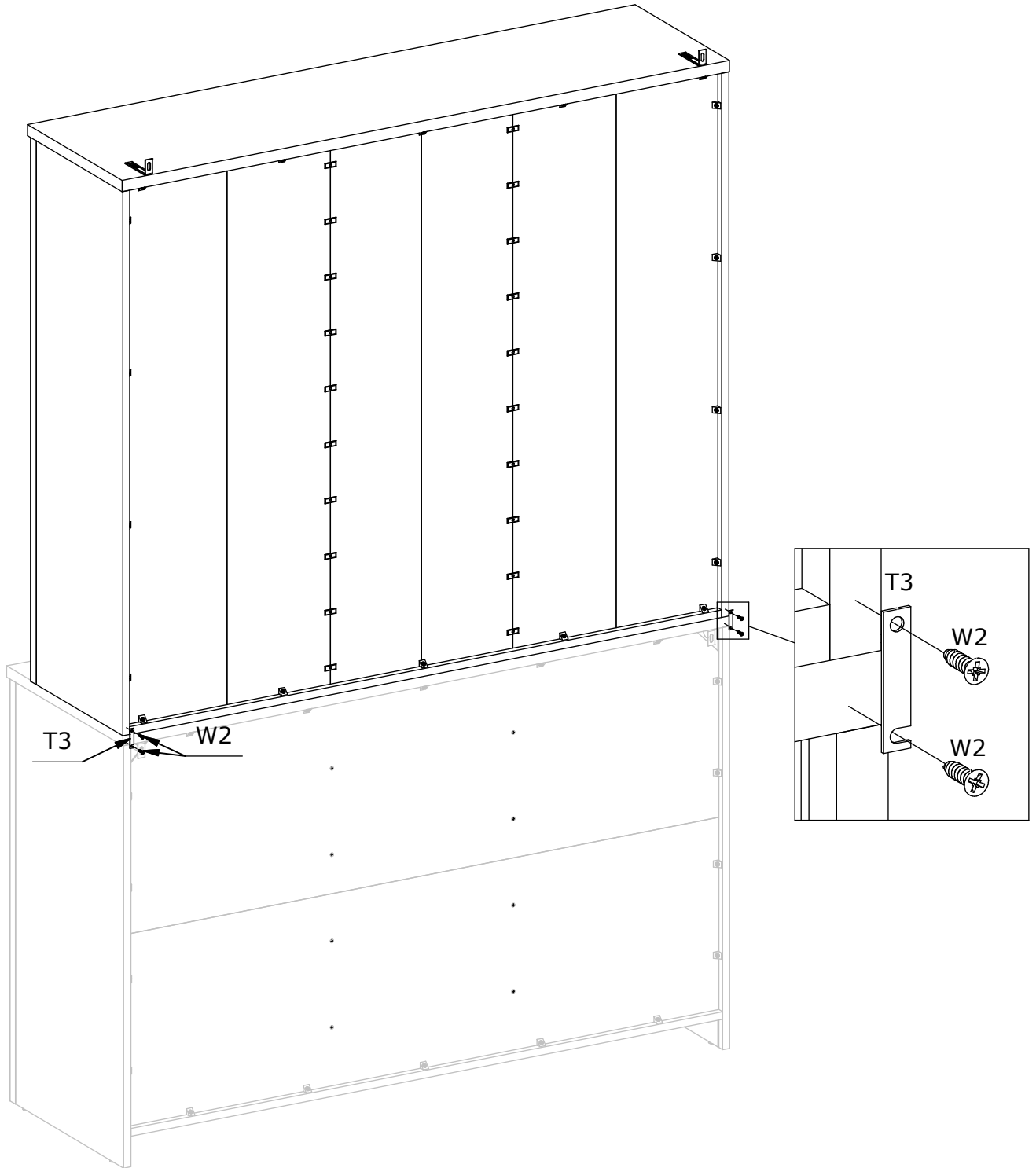
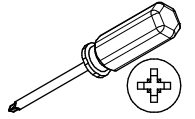

20

W2x4

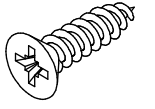

Ø3,5x16mm

T1 x2

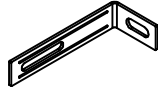

76x15mm

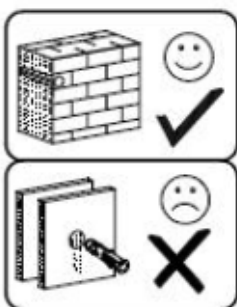
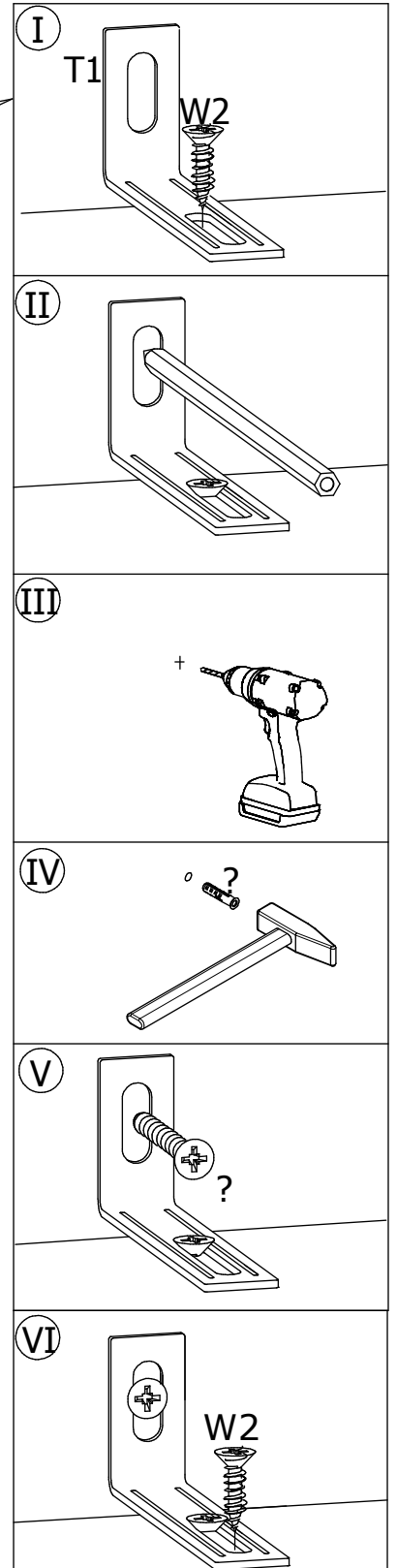
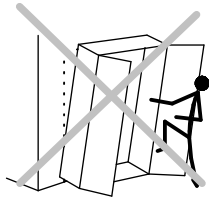
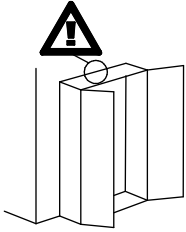
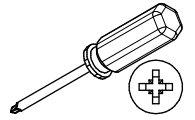

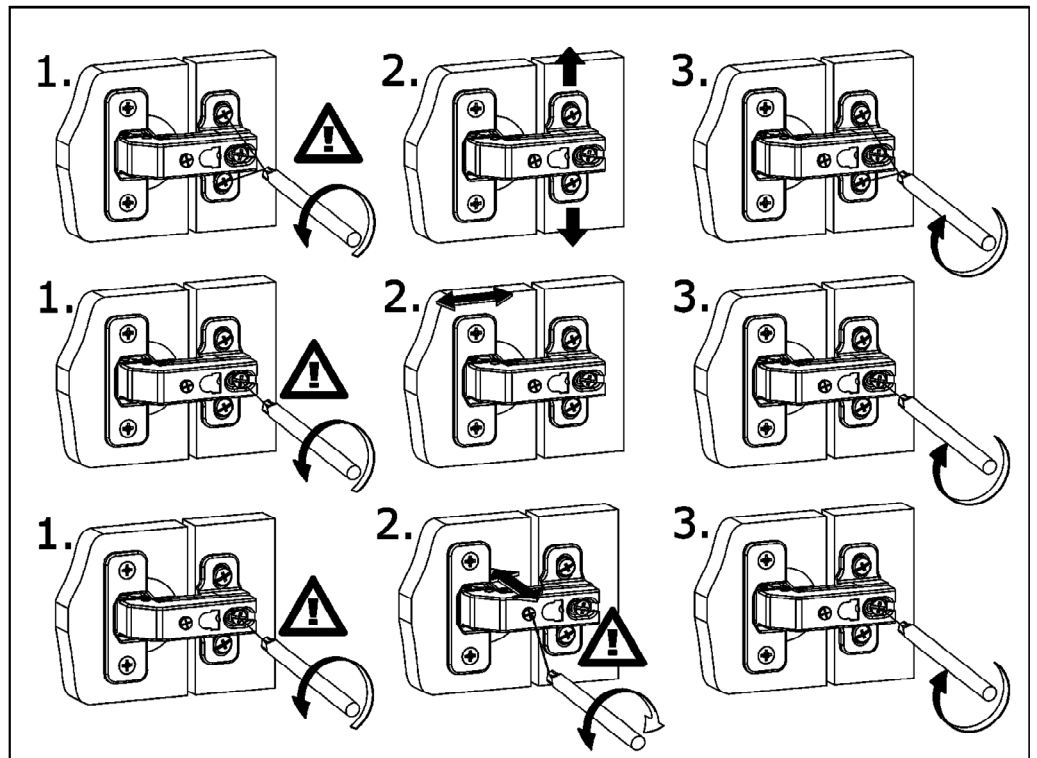
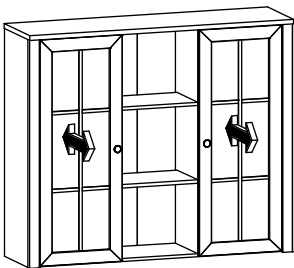
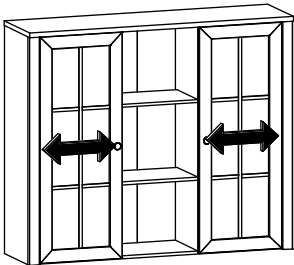
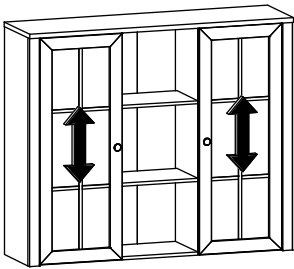
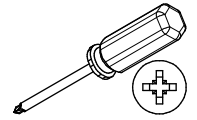

Name • Nom • Nome • Naam • Nazwa • Όνομα
• Názov • Név • Denumire • Isim • Имя

Nr • No • N° • Номер • Č • Sz

Typ • Type • Tip • Típus • Tipo • Tur

— —

D

Unser Direktservice für Beschädigte
Sollte Ihnen ein Beschädigter fehlen, können Sie diese Servicekarte direkt an die untersahende Nummer senden. Wir können allerdings nur Beschädigte auf diesem Weg verschicken. Sollen Sie eine andere Reparatur an Ihrem Möbelsstück haben, so wenden Sie sich bitte direkt an Ihr Möbelhaus.

GB

Our direct order service for fitting
If a fitting should be missing to you, you know this service map directly following number boxes. We can in this way send away however only fitting. If you should have another objection to your piece of furniture, then they turn please to your furniture house.

CZ

Naše přímé služby pro kování
Chybí-li vám nějaký díl z kování, můžete tuto servisní kartu odfaxovat přímo na níže uvedené číslo. Touto cestou však můžeme zaslát jen díly kování. Pokud byste reklamovali jiný díl nábytku, obraťte se přímo na svého prodejce nábytku.

F

Bien étudier la notice de montage
Repérez les pièces constituant votre meuble. Regroupez et contrôlez la quincaillerie. Munissez - vous de l'outillage nécessaire. Aménagez - vous une zone de montage. Procédez au montage. Ne jamais forcer les assemblages. Resserrez les vis après quelques temps d'usage. Garder votre notice de montage, si une pièce venait à manquer, elle serait le plus clair moyen de communiquer avec votre magasin.

I

Il nostro servizio diretto per l'ordine della ferramenta
Nel caso vi mancassero dei pezzi, potete spedire fax questa carta di servizi direttamente al seguente numero. Per altri reclami al vostro mobile, potete rivolgervi al vostro mobilificio.

BG

Директно одручбање на оштетен делови
Ако недостигаат делови од мебелот, можете да испратите овај сервисен формулар директно на адресата подолу. Можеме да испратиме само делови од мебелот. Ако имате друга повреда на мебелот, молиме да се обратите директно на вашиот продавач на мебелот.

NL

Onze directservice voor losse onderdelen
Wanneer er een onderdeel mist kunt u deze servicekaart direct aan onderstaand faxnummer sturen. Wij kunnen alleen langs deze weg onderdelen versturen. Mocht u een ander probleem aan uw meubel hebben verzoeken wij u contact op te nemen met uw meubeldealer.

PL

Nasz bezpośredni serwis części montażowych
Jeżeli brakuje części koniecznych do montażu, prosimy o przesłanie nam tej karty serwisowej na niżej podany numer faksu. Możemy w ten sposób przysłać państwu tylko brakujące części. W przypadku innych objętości dotyczących mebli, prosimy o zgłoszenie ich do salonu meblowego w którym został dokonany zakup.

HR

Servis za okove
U slučaju da nedostaje neki od dijelova molimo vas da na dolje nevedeni Fax broj pošaljete ovaj servisni obrazac. Na ovaj način mogu se dostaviti samo okovi. U slučaju da imate dodatne prigovore vezane uz komad namještaja molimo vas da se obratite izravno trgovini namještaja gdje je isti kupljen.

HU

Direktszolgáltatunk veszeltek esetén
Ha hiányzik egy veszeltek, ezt a kártyát közvetlenül elfaxolhatja az alább található faxszámra. Azonban csak a veszelteket tudunk így küldeni. Amennyiben másféle reklamáció áll fenn bútoráruházjait illetően, forduljon közvetlenül a bútorháznak.

SK

Naše priamy servis pre časti kovania
Ak by Vám chýbala nejaká časť kovania, môžete poslať túto servisnú kartu poslať faxom priamo na nižšie uvedené faxové číslo. Diely kovania vieme poslať iba týmto spôsobom. Ak by ste mali inú reklamáciu ohľadom Vášho nábytku, obráťte sa priamo na Vašu predajnú nábytku.

SLO

Naše direktno služne storitve za okovje
Ce vam manjka kakšno okovje, lahko to serviso kartico pošljete po faksu direktno na spodnjo številko. Po tej poti vam lahko pošljemo samo okovje. Če želite reklamirati kakšen drug del pohištva, se obrnite neposredno na vašo trgovino pohištva.

RO

Service-ul nostru direct pentru feronerie
In cazul in care va lipsesc o piesa de feronerie puteti sa trimitemi direct acest card de service pe fax la numarul de mai jos. Noi nu putem expedia piese de feronerie decat pe acestasi cale. Decat aveți o alta reclamație referitoare la piesa de mobilier, atunci vă rugăm să vă adresați direct la magazinul dvs. de mobilă.

RUS

Наш прямой сервис для поставок фурнитуры
Если окажется, что Вам не хватает того или иного элемента фурнитуры, Вы можете отправить сервисную карту по Факсу непосредственно на нижеприведенный номер. Однако, таким образом мы можем переслать лишь фурнитуру. Если же у Вас возникнут иные претензии относительно приобретенной мебели, пожалуйста, обращайтесь непосредственно в организацию, осуществившую продажу.

S







Vår direktservice för beslagdelar
Om du saknar en beslagdel kan du faxa detta servicekort direkt till numret som anges ned. Tänk på att detta är den enda möjligheten att skicka beslagdelar till dig. Om du vill reklamera din möbel av en annan anledning måste du kontakta ditt möbelhus direkt.

ES

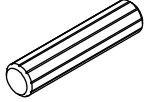
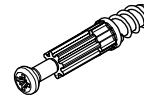
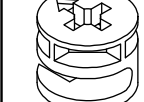
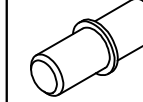
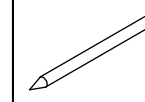
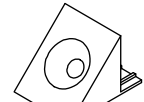
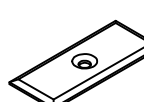
Nuestro servicio directo para accesorios
Si le falta algún accesorio, puede enviar esta tarjeta de servicio directamente a la siguiente dirección. No obstante, por este método solo podemos enviar accesorios. Si tiene alguna otra objeción sobre su mueble, consulte directamente con su mueblería.

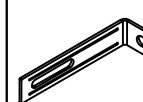
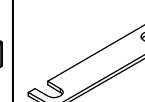
TR

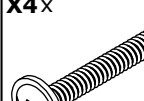
Donatılar için doğrudan servisimiz
Bir donatınız eksikse bu servis kartını doğrudan aşağıda bulunan adrese doğrudan mail yazabilirsiniz. Sadece bu yolla donatıları gönderebiliriz. Mobilyanızda başka şikayetleriniz varsa lütfen doğrudan mobilya satışçınıza danışın.

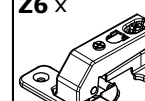
A1 x  Ø8x35mm	B1 x  Ø5x38mm	C1 x  Ø15x12mm	E1 x  Ø5x16mm	G1 x  26mm
G2 x  14x14mm	G3 x  22x10mm	J11 x  Ø21mm	T1 x  76x15mm	T3 x  50x9mm
U2 x  Ø33mm	W2 x  Ø3,5x16mm	X4 x  M4x25mm	Y1 x  Ø8mm	Z6 x  Ø35mm, 90°

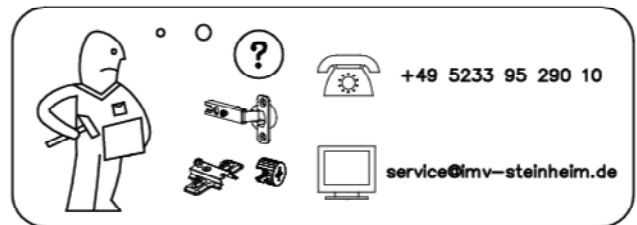
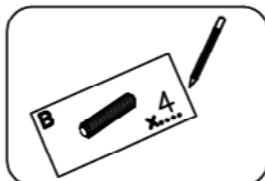

+49 5233 95 290 10

service@mv-steinheim.de

Name • Nom • Nome • Naam • Nazwa • Όνομα
• Názov • Név • Denumire • Isim • Имя

Nr • No • N° • Номер • Č • Sz

Typ • Type • Tip • Tipus • Tipo • Тип

— —

D

Unser Direktservice für Beschlegetelle
Sollte Ihnen ein Beschlegeteil fehlen, können Sie diese Servicekarte direkt an die untenstehende Nummer senden. Wir können allerdings nur Beschlegeteile auf diesem Weg verschicken. Sollen Sie eine andere Beanstandung an Ihrem Möbelstück haben, so wenden Sie sich bitte direkt an Ihr Möbelhaus.

GB

Our direct order service for fitting
If a fitting should be missing to you, you know this service map directly following number boxes. We can in this way send away however only fitting. If you should have another objection to your piece of furniture, then they turn please to your furniture house.

CZ

Naše přímé služby pro kování
Chybí-li vám nějaký díl z kování, můžete tuto servisní kartu odfaxovat přímo na níže uvedené číslo. Touto cestou však můžeme zaslát jen díly kování. Pokud byste reklamovali jiný díl nábytku, obraťte se přímo na svého prodejce nábytku.

F

Bien étudier la notice de montage
Repérez les pièces constituant votre meuble. Regroupez et contrôlez la quincaillerie. Munissez-vous de l'outillage nécessaire. Aménagez-vous une zone de montage. Procédez au montage. Ne jamais forcer les assemblages. Resserrez les vis après quelques temps d'usage. Garder votre notice de montage, si une pièce venait à manquer, elle serait le plus clair moyen de communiquer avec votre magasin.

I

Il nostro servizio diretto per l'ordine della ferramenta
Nel caso vi mancessero dei pezzi, potete spedire fax questa carta di servizio direttamente al seguente numero. Per altri reclami al vostro mobile, potete rivolgervi al vostro mobilificio.

BG

Директно обслужаване на отделилите част "Обзор"
Ако ви липне некаква част, можете да изпратите директно на следното телефонно число тази карта за директно обслужаване на отделилите част "Обзор". Ако имате друга претензия относно мебелта, моля да се свържете директно с вашия магазин.

NL

Onze directservice voor losse onderdelen
Wanneer er een onderdeel mist kunt u deze servicekaart direct aan onderstaand faxnummer sturen. Wij kunnen alleen langs deze weg onderdelen versturen. Mocht u een ander probleem aan uw meubel hebben verzaken wij u contact op te nemen met uw meubeldealer.

PL

Nasz bezpośredni serwis części montażowych
Jeżeli brakuje części koniecznych do montażu, prosimy o przesłanie nam tej karty serwisowej na niżej podany numer faxu. Możemy w ten sposób przysłać państwu tylko brakujące części. W przypadku innych objeży dotyczących mebla, prosimy o zgłoszenie ich do salonu meblowego w którym został dokonany zakup.

HR

Servis za okove
U slučaju da nedostaje neki od dijelova molimo vas da na dolje nevedeni Fax broj pošaljete ovaj servisni obrazac. Na ovaj način mogu se dostaviti samo okovi. U slučaju da imate dodatne prigovore vezane uz komad namještaja molimo vas da se obratite izravno trgovini namještaja gdje je isti kupljen.

HU

Direktszolgálatunk veszelatok esetén
Ha hiányzik egy veszelat, ezt a kártyát közvetlenül elfaxolhatja az alább található faxszámra. Azonban csak a veszelatokat tudunk így küldeni. Amennyiben másfajta reklamáció áll fenn bútoráruhájt illetően, forduljon közvetlenül a bútorházhoz.

SK

Naše priame služby pre besú kovania
Ak by Vám chýbala nejaká časť kovania, môžete poslať túto servisnú kartu poslať faxom priamo na nižšie uvedené faxové číslo. Diely kovania vieme poslať iba týmto spôsobom. Ak by ste mali inú reklamáciu ohľadom Vášho nábytku, obráťte sa priamo na Vašu predajnú nábytku.

SLO

Naše direktne služne storitve za okovje
Ce vam manjka kakšno okovje, lahko to servisno kartico pošljete po faxu direktno na spodnjo številko. Po tej poti vam lahko pošljemo samo okovje. Če imate reklamacijo kakšne druge del pohištva, se obrnite neposredno na vašo trgovino pohištva.

RO

Service-ul nostru direct pentru feronerie
In cazul in care va lipsesc o piesa de feronerie puteti sa trimitezi direct acest card de service pe fax la numarul de mai jos. Noi nu putem expedia piese de feronerie decat pe acestul cale. Decit avezi o alta reclamatie referitoare la piese de mobilier, atunci va rugam sa va adresati direct la magazinul dvs. de mobilier.

RUS

Наш прямой сервис для поставок фурнитуры
Если окажется, что Вам не хватает того или иного элемента фурнитуры, Вы можете отправить сервисную карту по Факсу непосредственно на нижеприведенный номер. Однако, таким образом мы можем переслать лишь фурнитуру. Если же у Вас возникнут иные претензии относительно приобретенной мебели, пожалуйста, обращайтесь непосредственно в организацию, осуществляющую продажу.

S

Vår directservice för beslagdelar
Om du saknar en beslagdel kan du faxa detta servicekort direkt till numret som anges ned. Tänk på att detta är den enda möjligheten att skicka beslagdelar till dig. Om du vill reklamera din möbel av en annan anledning måste du kontakta ditt möbelhus direkt.

ES

Nuestro servicio directo para accesorios
Si le falta algún accesorio, puede enviar esta tarjeta de servicio directamente a la siguiente dirección. No obstante, por esta vía solo podemos enviar accesorios. Si tiene alguna otra objeción sobre su mueble, consulte directamente con su mueblería.

TR

Donatılar için doğrudan servisimiz
Bir donatınız eksikse bu servis kartını doğrudan aşağıda bulunan adrese doğrudan mail yazabilirsiniz. Sadece bu yolla donatılar gönderiliriz. Mobilyanızda başka şikayetiniz varsa lütfen doğrudan mobilya satışınıza danışın.

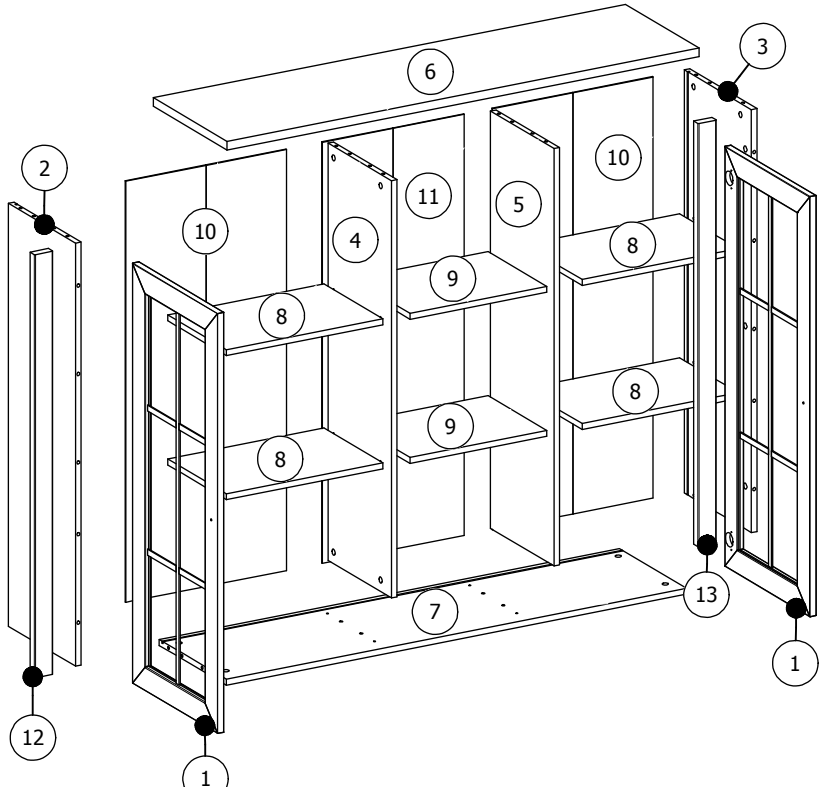

nr	L[mm]	B[mm]	T[mm]	Menge	Colli
1	1064	405	18	2	3/3
2	1072	320	15	1	1/3
3	1072	320	15	1	1/3
4	1057	302	15	1	2/3
5	1057	302	15	1	2/3
6	1299	350	22	1	2/3
7	1266	320	15	1	2/3
8	430	280	15	4	1/3
9	376	280	15	2	1/3
10	1067	442	2,5	2	2/3
11	1067	390	2,5	1	2/3
12	1072	50	22	1	1/3
13	1072	50	22	1	1/3

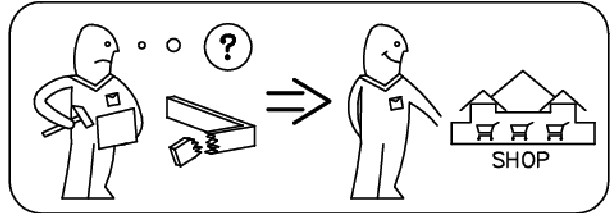



Achtung • Opgelet • Uwaga • Dikkat • Вниманіе •
 Attention • Upozorneni • Figyelem • Allenzione • Atentie



D	Überschreiten Sie die angegebenen Maximalbelastungen nicht. Andernfalls kann das Möbelstück beschädigt oder zerstört werden.
GB	Do not exceed the maximum loads specified. Otherwise, the furniture may sustain damage or be irreparably damaged.
NL	Overschrijd de aangegeven maximale belastingen niet. Anders kan het meubelstuk worden beschadigd of vernield.
PL	Nie wolno przekraczać podanych maksymalnych wartości obciążenia. W innym przypadku można mebel uszkodzić lub zniszczyć.
TR	Belirtilen azami yuk degerini asmayiniz, aksi taktirde mobilya parcasi zarar gorebilir veya kullanilamazehale gelebilir.
RU	Не допускается превышение указанных максимальных нагрузок. В противном случае возможно повреждение или разрушение мебели.
FR	Ne dépassez pas les charges maximum indiquées. Sinon, le meuble peut être endommagé ou détruit.
CZ	Nepřekračujte uvedené maximální zatížení. V opačném případě může dojít k poškození nebo zničení nábytku.
HU	Tartsa be az engedélyezett maximális terhelhetőséget/teljesítményt. Különben a bútor és annak alkatrészei megsérülhetnek, tönkre mehetnek.
IT	Non superare il carico massimo indicato. Altrimenti il mobile rischia di rovinarsi o frantumarsi.
RO	Nu depasiti solicitările maxime specificate. Altfel puteti sa deteriorati sau sa distrugeti piesa de mobilier.
SK	Neprekročte uvedené maximálne zaťaženia. V opačnom prípade sa môže nábytok poškodiť alebo zničiť.

D	Die Befestigung des Möbelstückes an der Wand muss von einer fachkundigen Person vorgenommen werden, da für die Montage an die Wand angepasste Dübel erforderlich sind.
GB	A qualified professional is required when mounting furniture to the wall since dowels corresponding to the wall are required for this.
NL	Een vakkundige persoon dient het meubelstuk aan de muur te bevestigen; voor de montage aan de muur zijn immers aangepaste pluggen vereist.
PL	Mocowanie mebla do ściany mogą przeprowadzić wyłącznie wykwalifikowane osoby, z uwagi na zastosowanie odpowiednio dopasowanych kołków do rodzaju ściany.
TR	Mobilya parçasının duvara sabitlemesi, duvar montajı için özel uyarlanmış dübeller gerektirdiğinden bu iş sadece bu konuda uzman bir kişi tarafından gerçekleştirilmelidir.
RU	Поскольку для монтажа на стене необходимо использовать специальные дюбели, мебель должна быть закреплена на стене квалифицированным персоналом.
FR	La fixation du meuble contre le mur doit être effectuée par une personne compétente car, pour le montage mural, il faut utiliser des chevilles adaptées.
CZ	Montáž nábytku na stěnu musí provést odborník, protože k montáži na stěnu jsou zapotřebí upravené hmoždinky.
HU	A bútorlemek falra rögzítését szakembernek kell végeznie, mert a rögzítéshez megfelelő tiplít kell használni.
IT	Il fissaggio del mobile alla parete deve essere eseguito esperte, dato che occorrono tasselli adeguati.
RO	Fixarea la perete a piesei de mobilier se realizeaza numai de catre personal competent, deoarece montajul de perete necesita dibluri adecvate.
SK	Upevnenie nábytku na stenu musí vykonať odborník, nakoľko sú pre montáž na stenu potrebné vhodné hmoždinky.

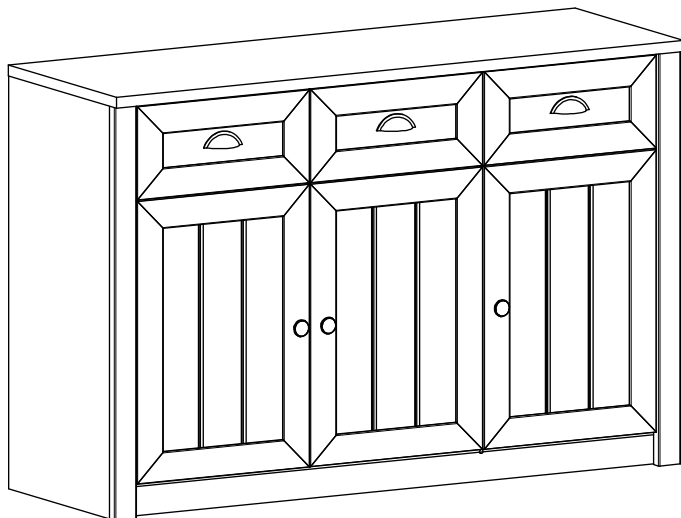

- ⓓ Montageanleitung
- ⓃL Handleiding voor de montage
- ⓉR Montaj talimati
- ⓕ Notice de montage
- ⒸZ Montážni návod
- ⓗU Szerelési útmutató
- ⓖB Assembly instructions
- ⓅL Instrukcja montażu
- ⓇU Инструкция по монтажу
- ⓇT Istruzioni di montaggio
- ⓈK Návod na montáž
- ⓇO Instrucțiuni de montaj
- ⓔS Instrucciones de montaje

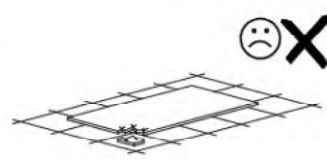
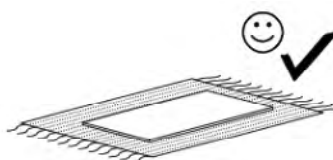
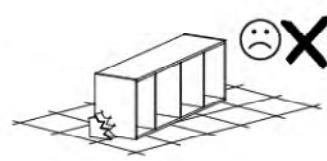
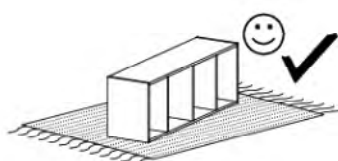
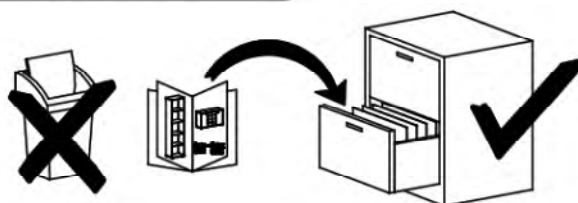
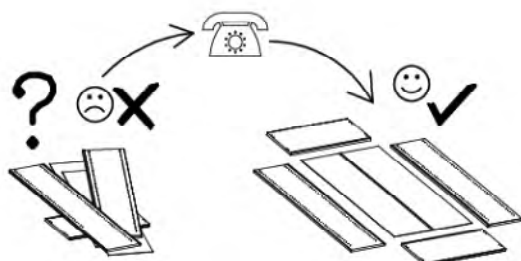
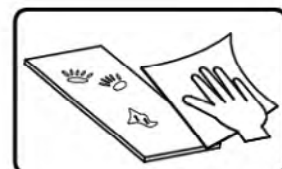
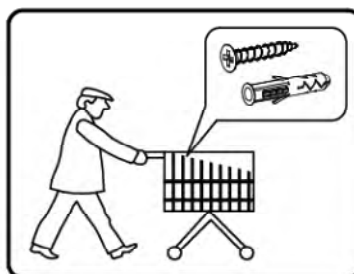
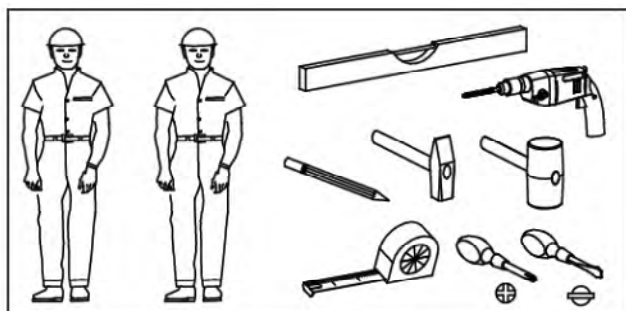

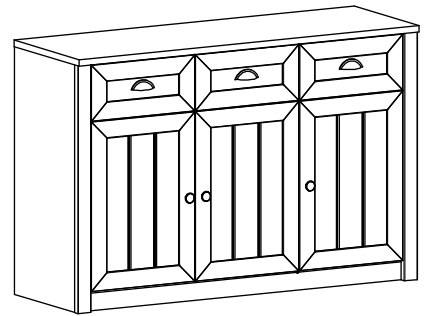

A1 x24

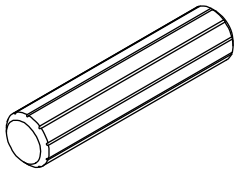

Ø8x35mm

B1 x24

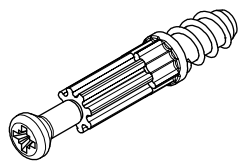

Ø5x38mm

C1 x24

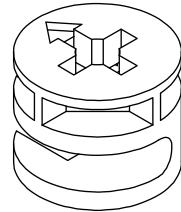

Ø15x12mm

E1 x12

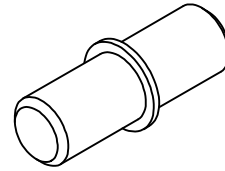

Ø5x16mm

F2 x4

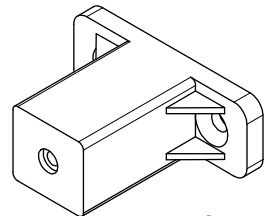

40mm

G2 x18

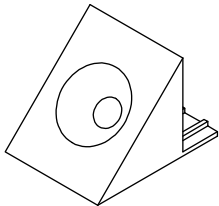

14x14mm

J11 x20

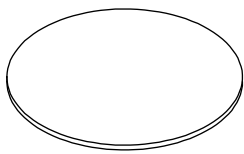

Ø21mm

K1 x16

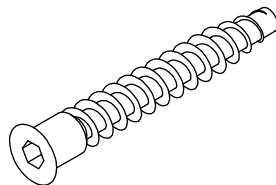

Ø6,4x50mm

N2 x1



4mm HEX

P2 x6

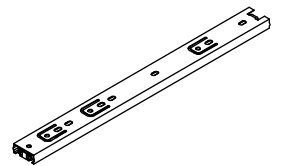

350mm

R1 x3

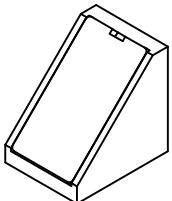

24x24x19mm

T1 x2

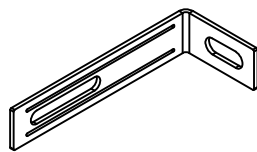

76x15mm

U2 x3

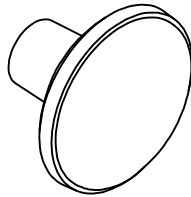

Ø33mm

U4 x3

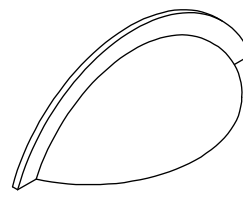

92x33mm

W2 x113

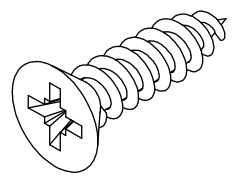

Ø3,5x16mm

W5 x4

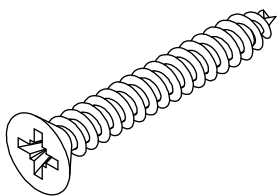

Ø4x30mm

X2 x6

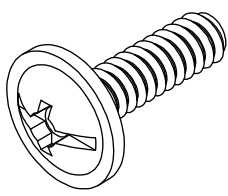

M4x16mm

X4 x3

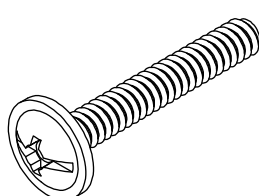

M4x25mm

Y1 x6

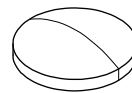

Ø8mm

Y2 x8

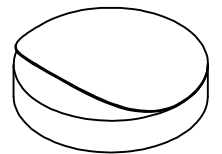

Ø16mm

Z1 x2

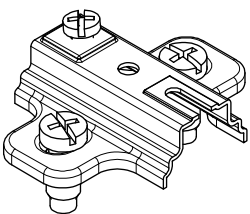

50x40, H=2

Z4 x2

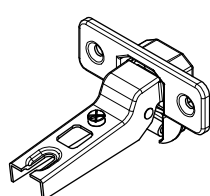

Ø35mm, ZK9

Z6 x4

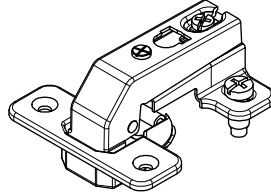

Ø35mm, 90°

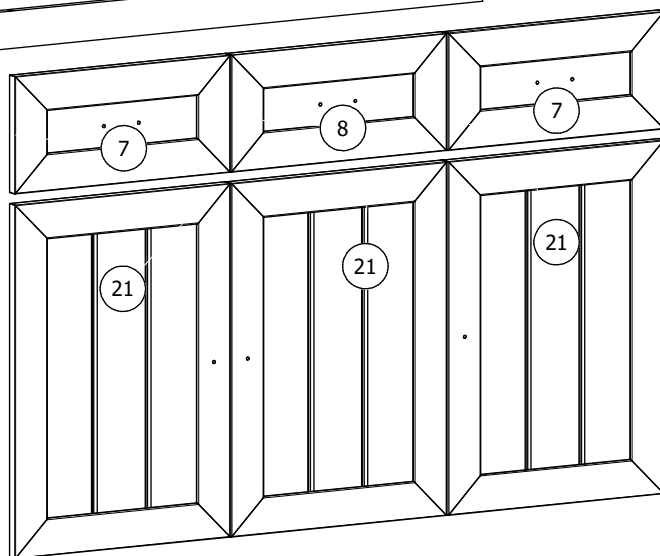
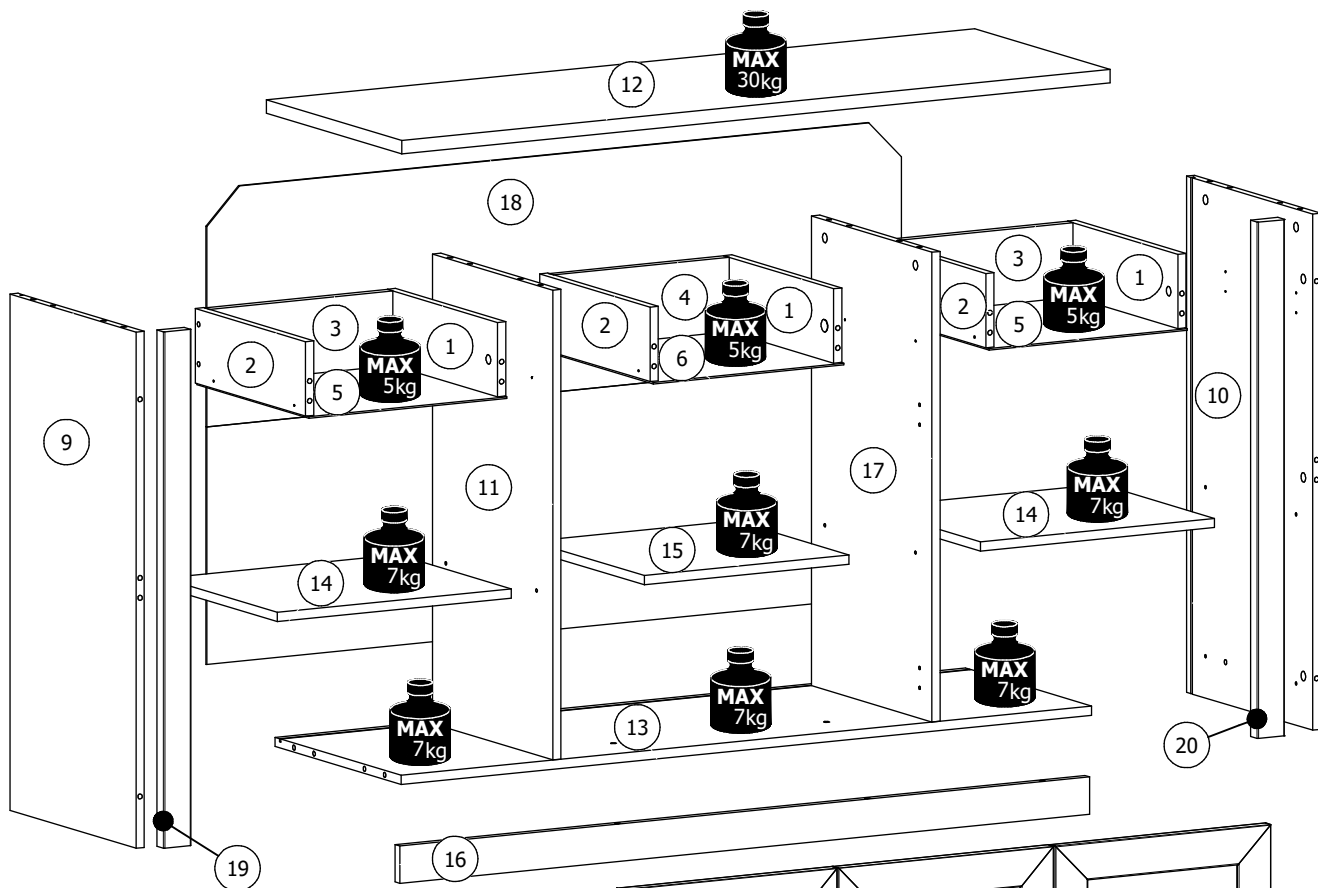

nr	L[mm]	B[mm]	T[mm]	Menge	Colli
1	120	350	15	3	3/3
2	120	350	15	3	3/3
3	120	336	15	2	3/3
4	120	322	15	1	3/3
5	363	355	2,5	2	1/3
6	349	355	2,5	1	1/3
7	395	189	18	2	2/3
8	395	189	18	1	2/3
9	832	400	15	1	1/3
10	832	400	15	1	1/3
11	757	382	15	1	1/3
12	1299	430	22	1	3/3
13	1266	400	15	1	3/3
14	429	360	15	2	1/3
15	375	360	15	1	1/3
16	1265	60	15	1	3/3
17	757	382	15	1	1/3
18	766	1274	2,5	1	3/3
19	832	50	22	1	1/3
20	832	50	22	1	1/3
21	395	570	18	3	2/3

1

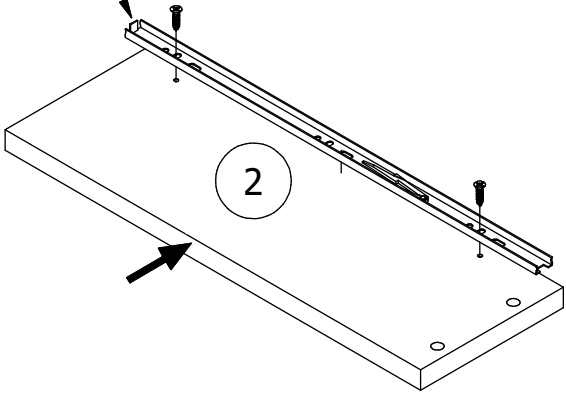
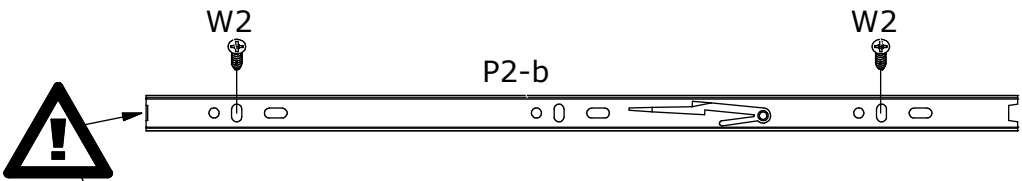
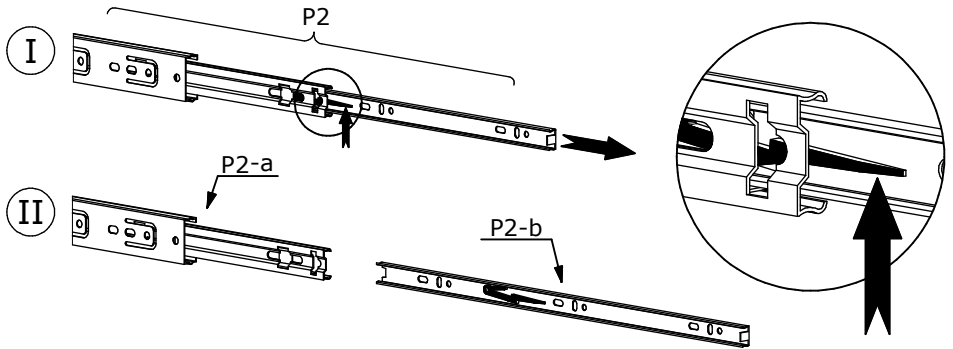
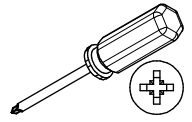
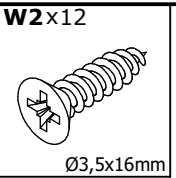
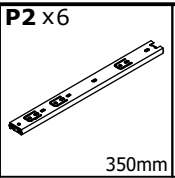
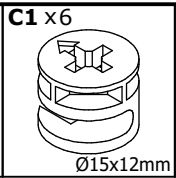
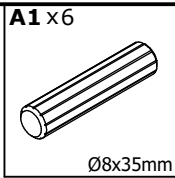

x3

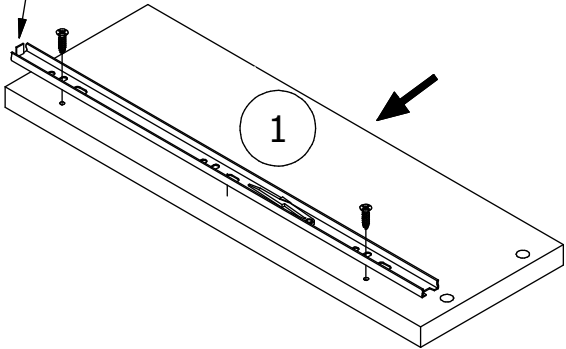
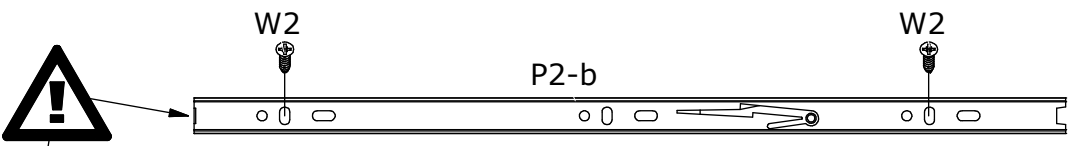
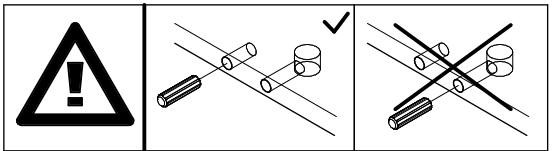
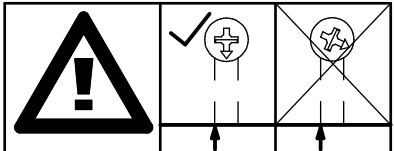
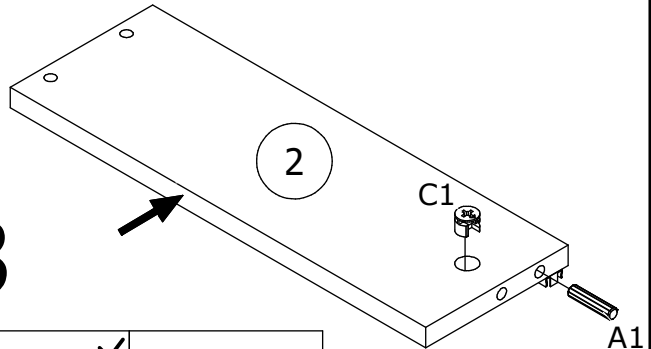

x3

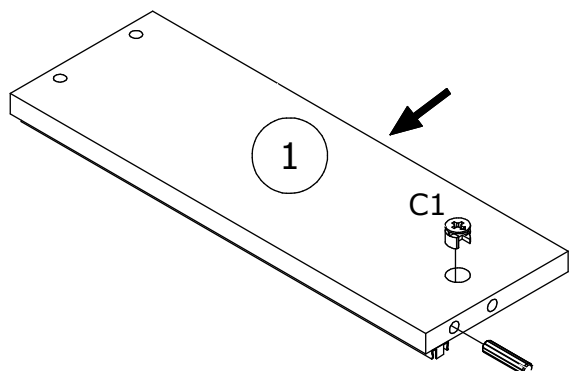

2

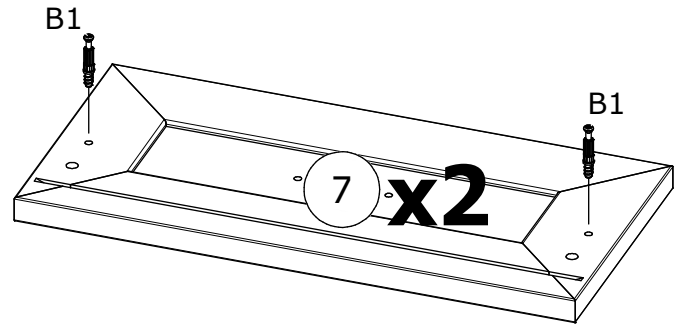
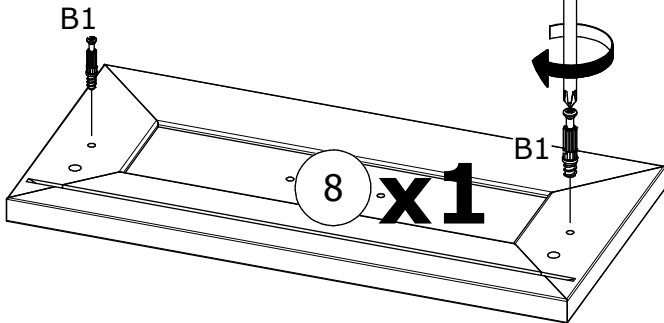
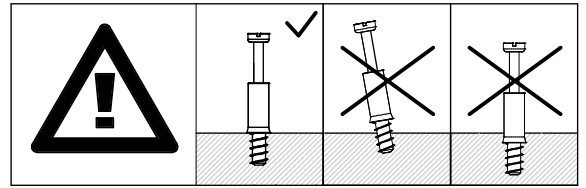
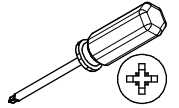
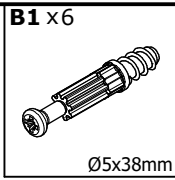

3

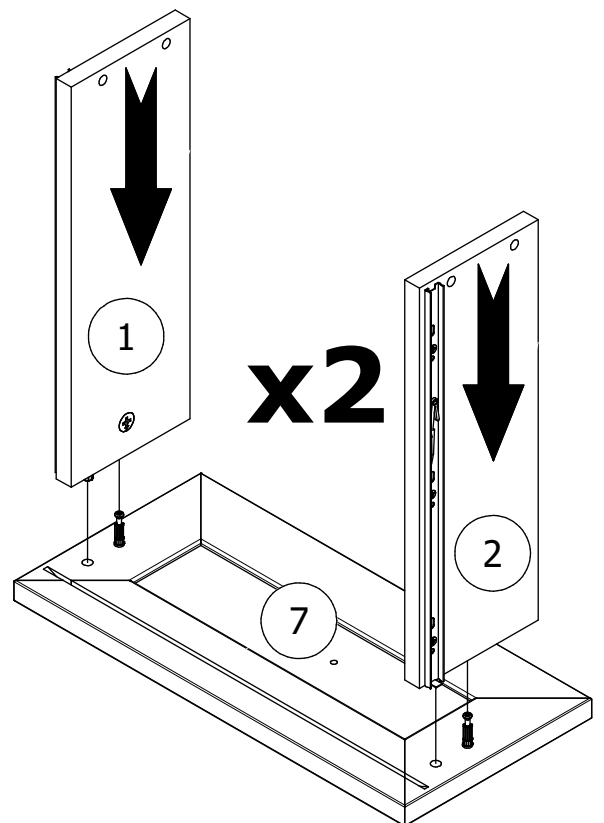
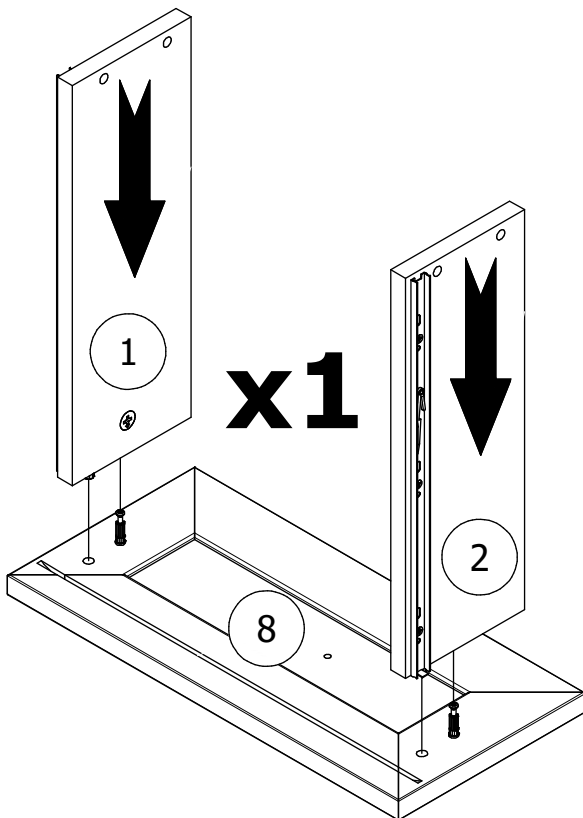
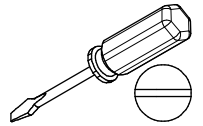
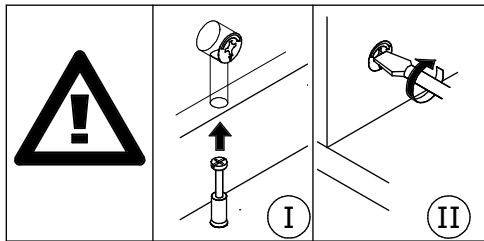

4

K1x12

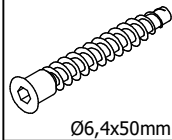

N2x1

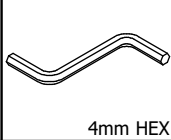

J11x6

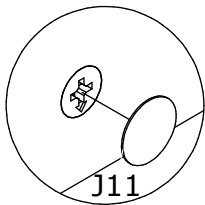
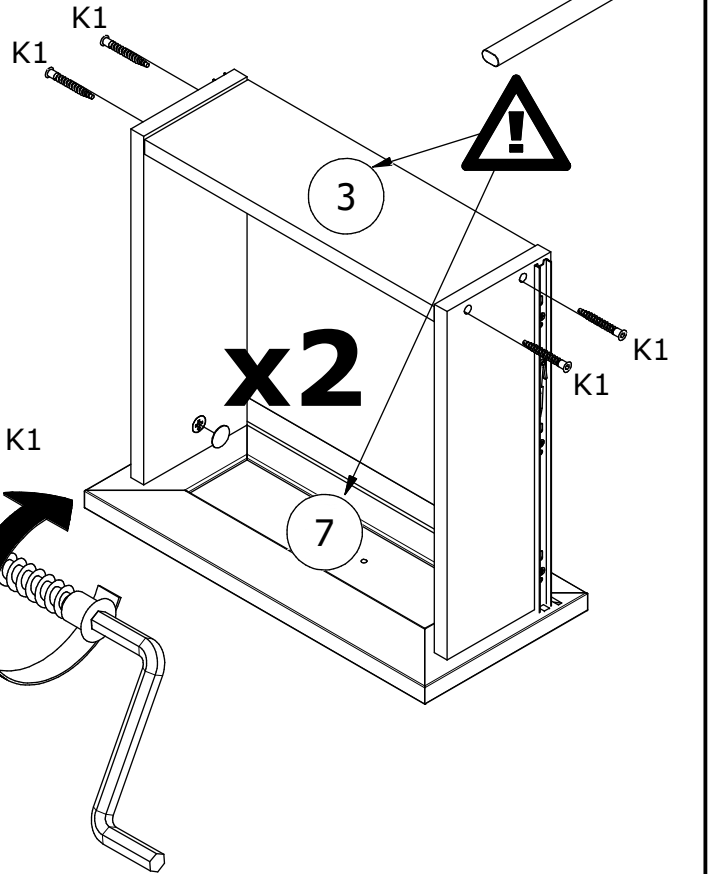
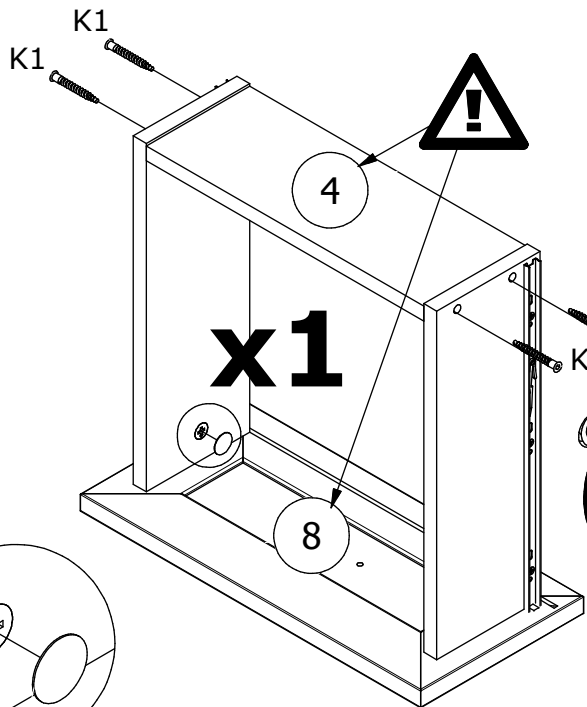
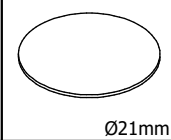

5

W2x27

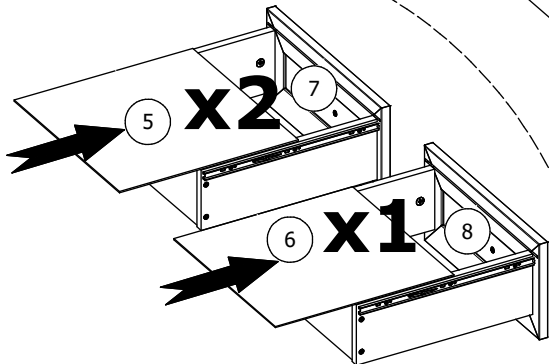
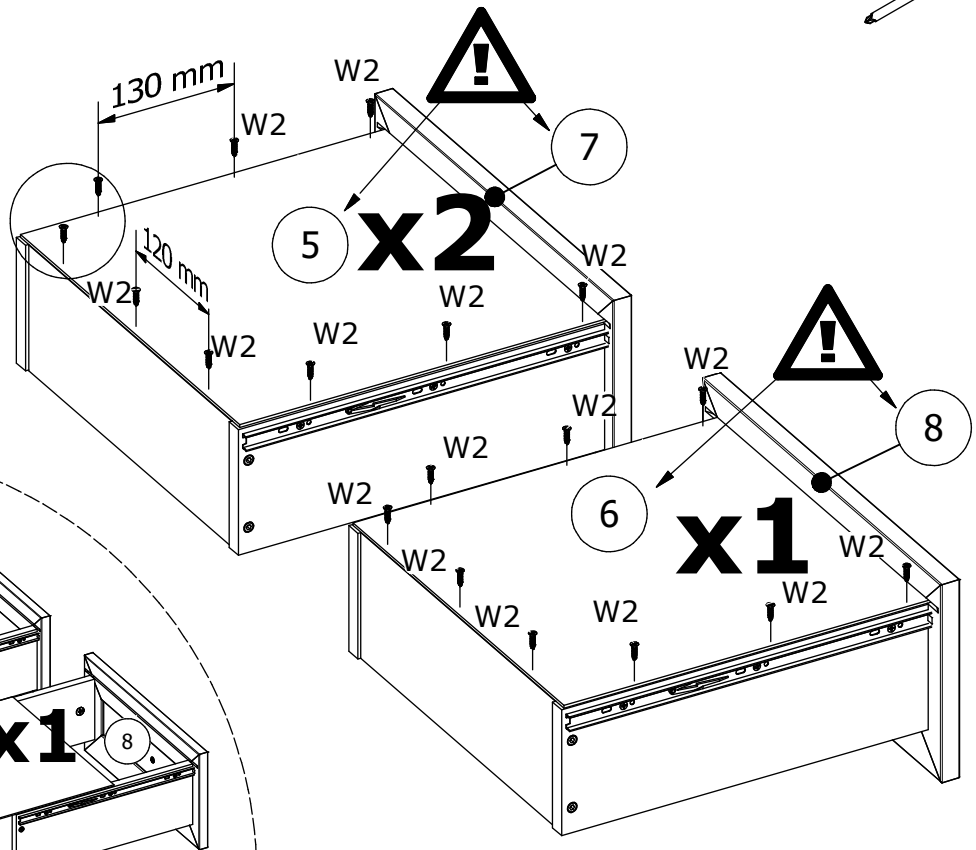
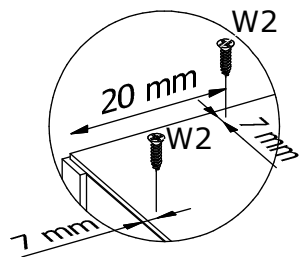
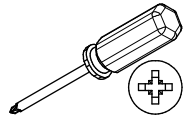
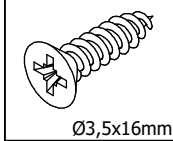

6

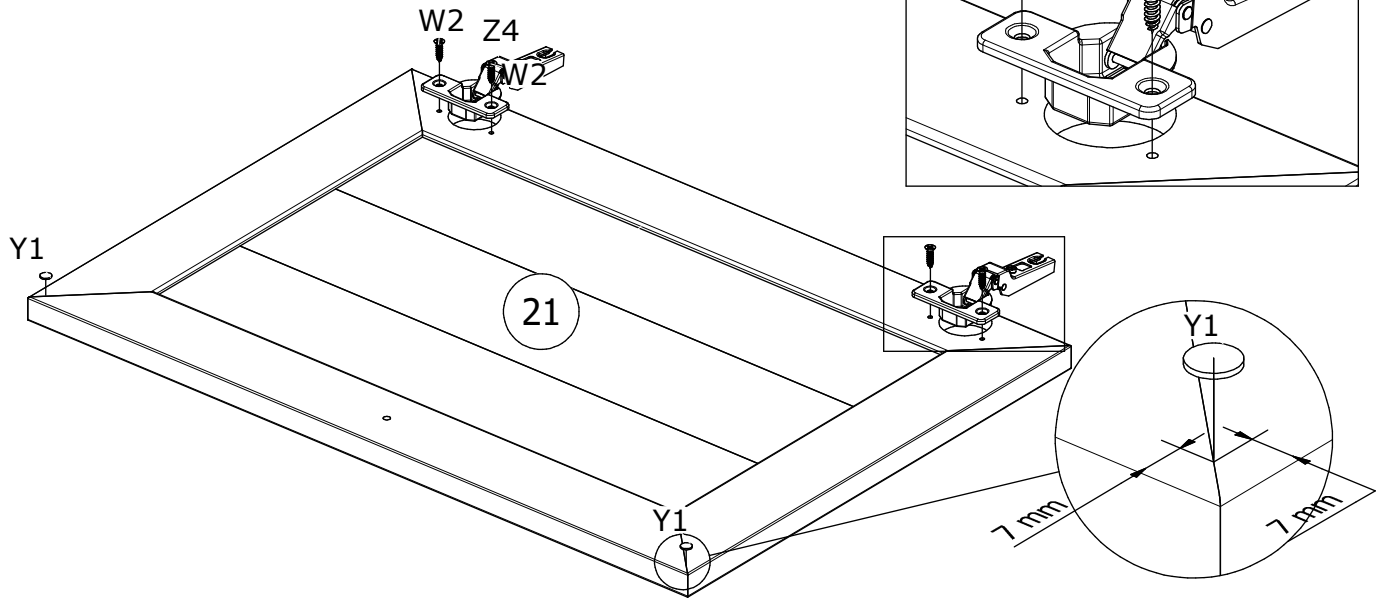
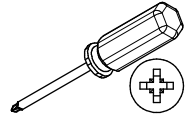
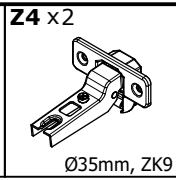
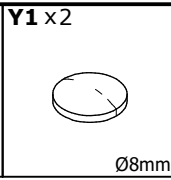
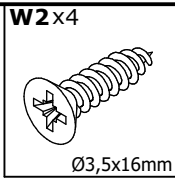

7

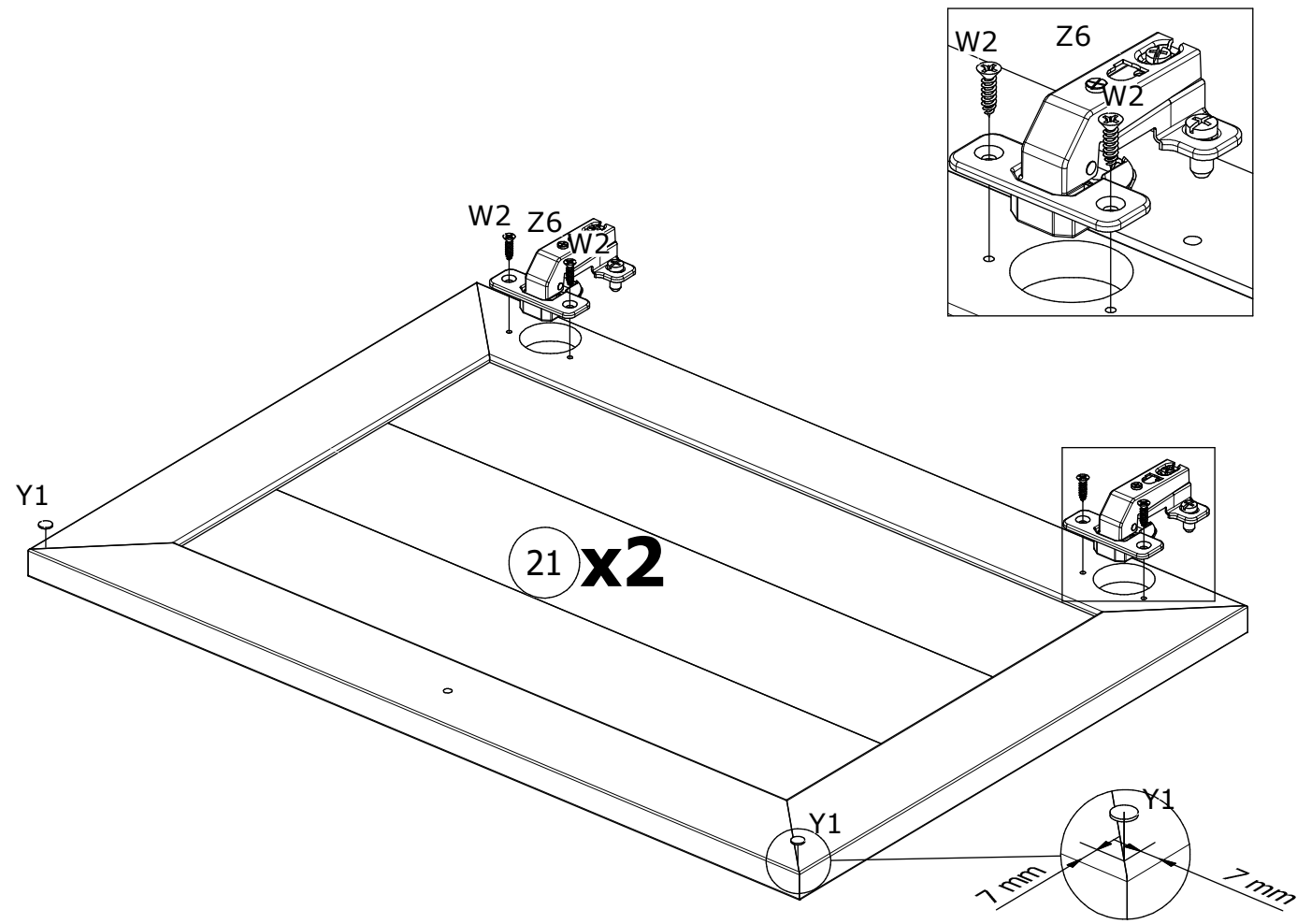
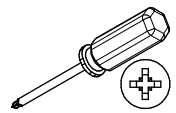
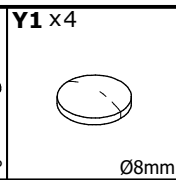
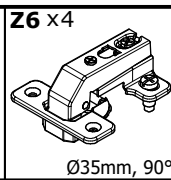
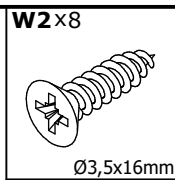

8

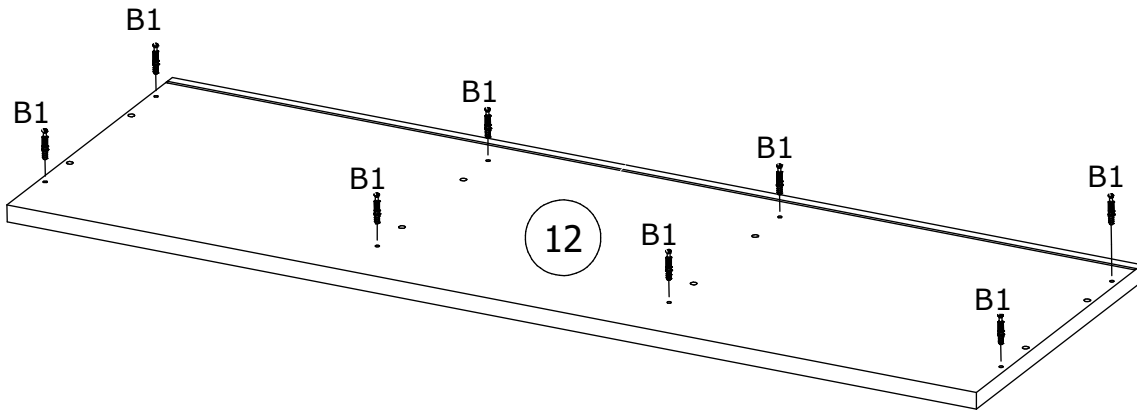
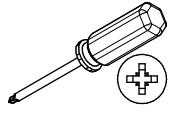
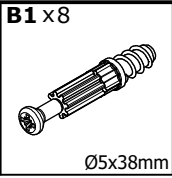

9

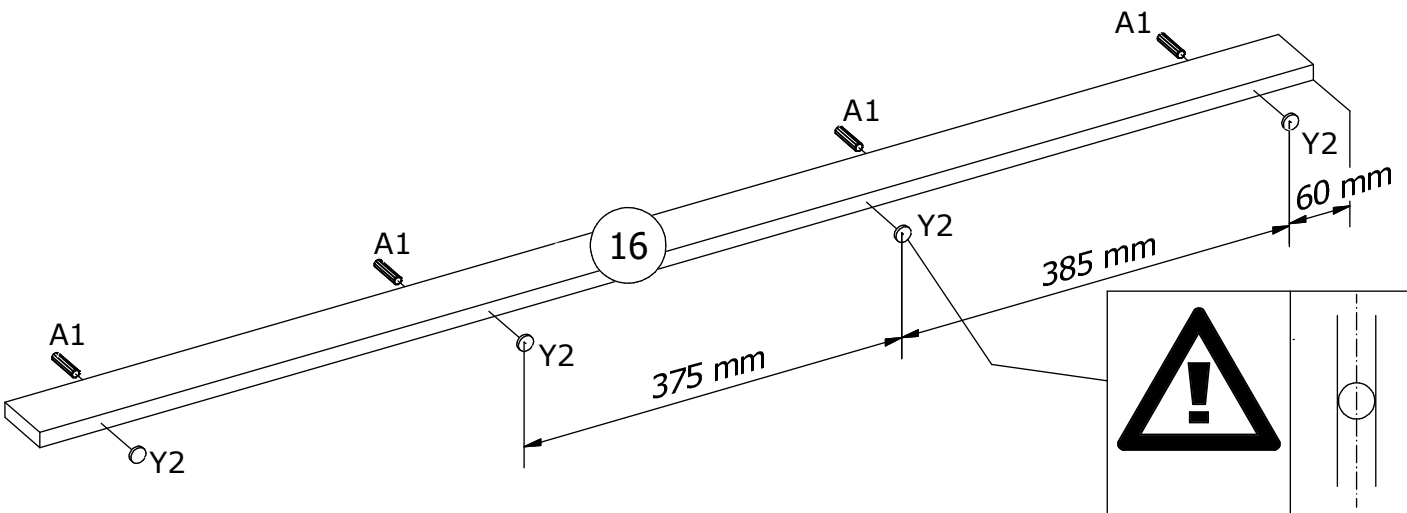
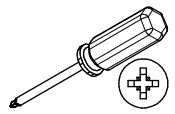
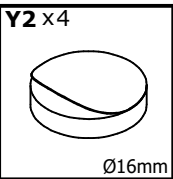
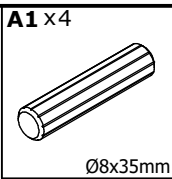

10

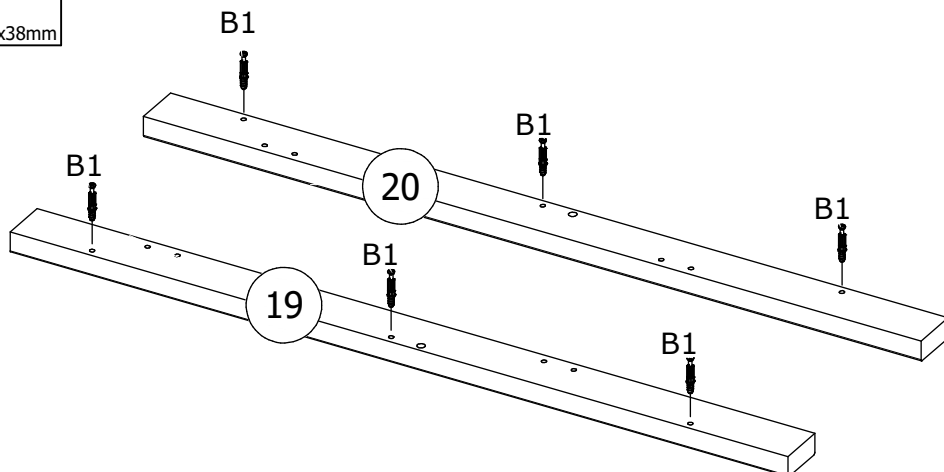
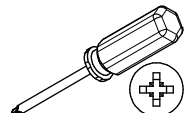
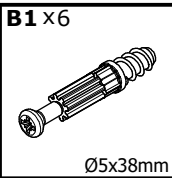

12

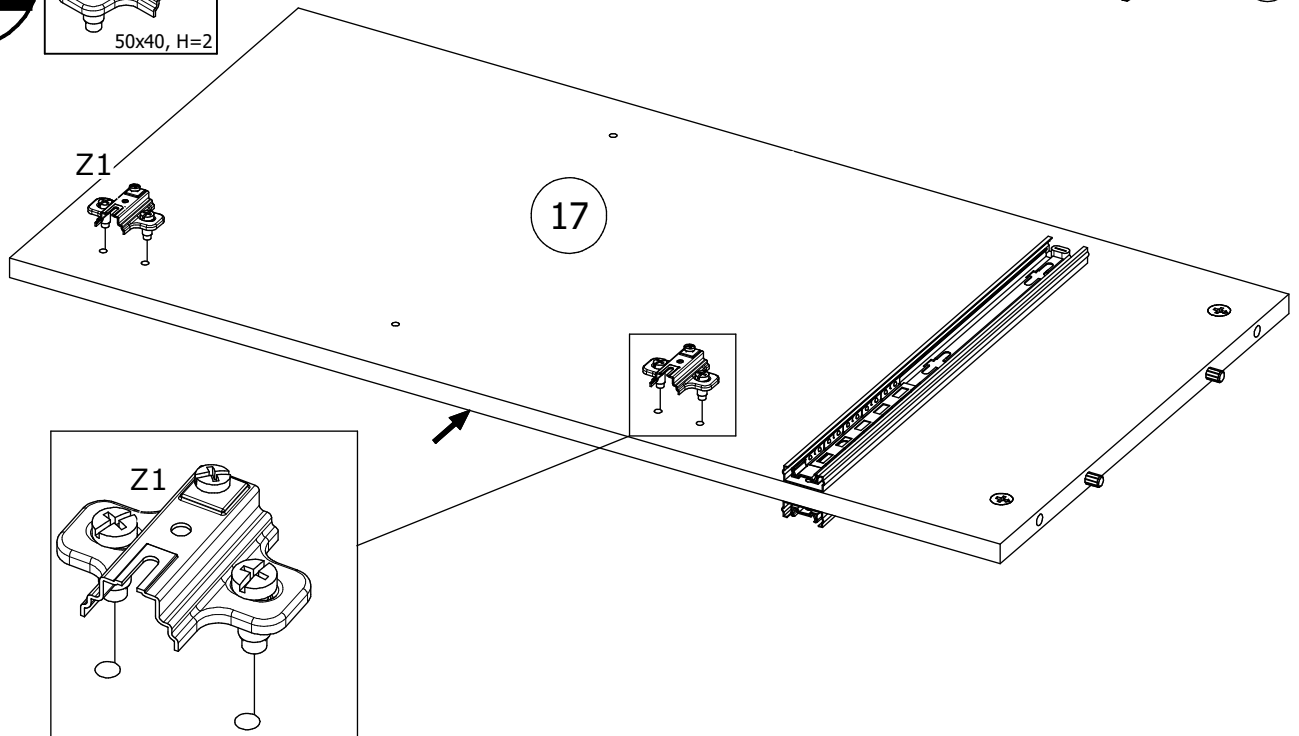
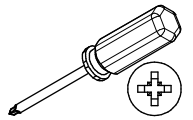
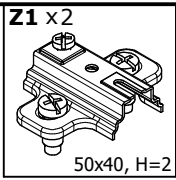

13

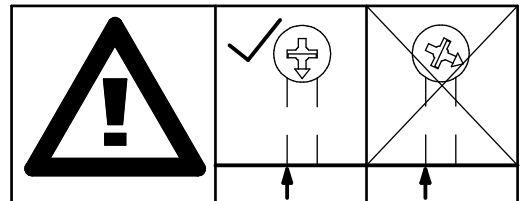
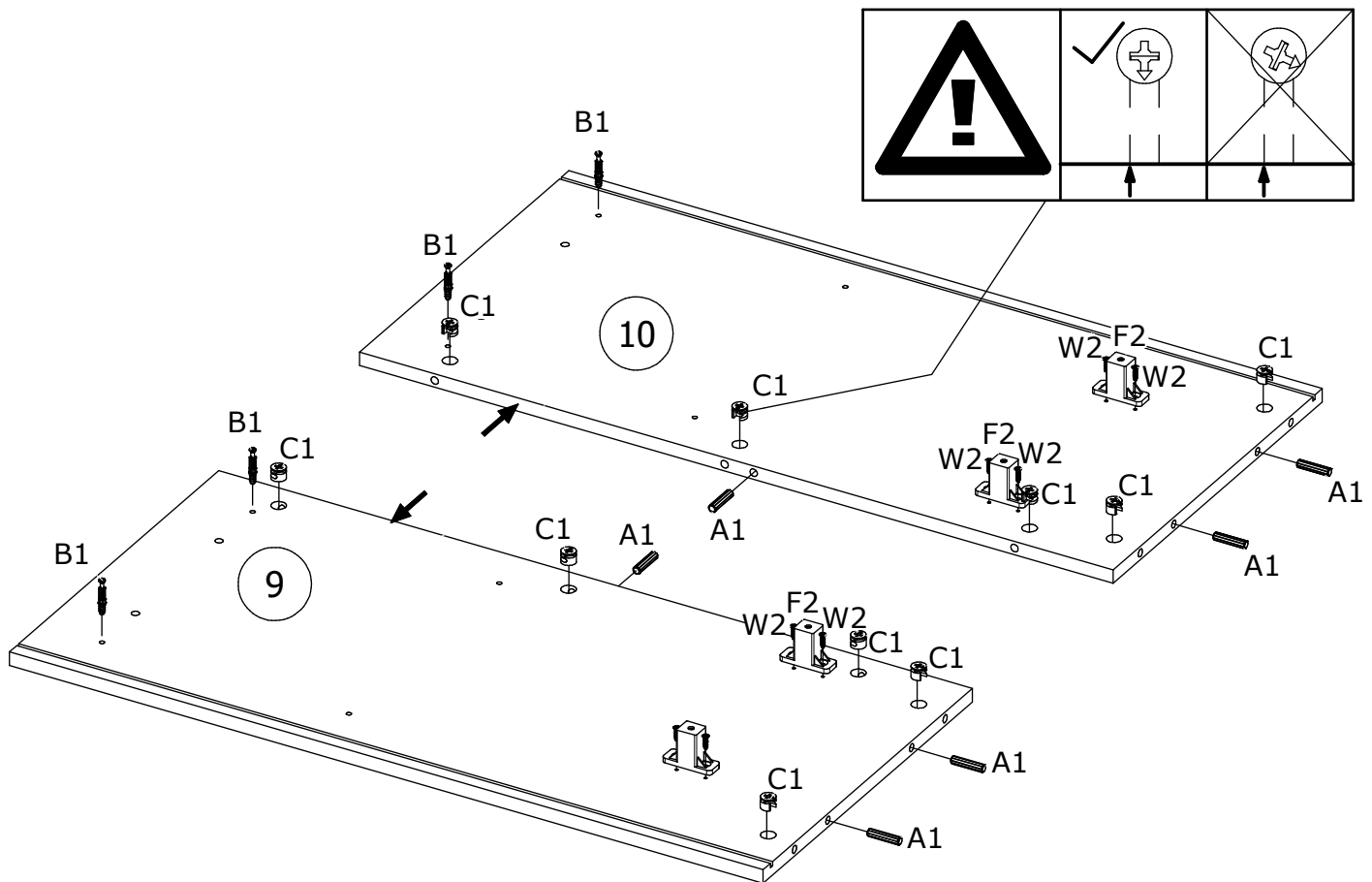
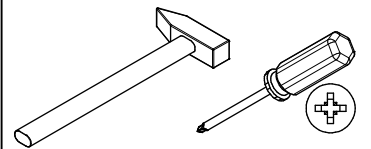
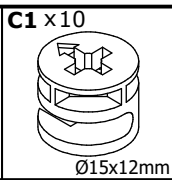
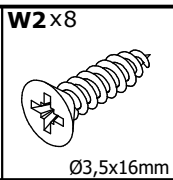
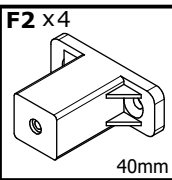
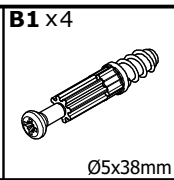
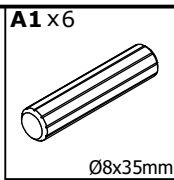

14

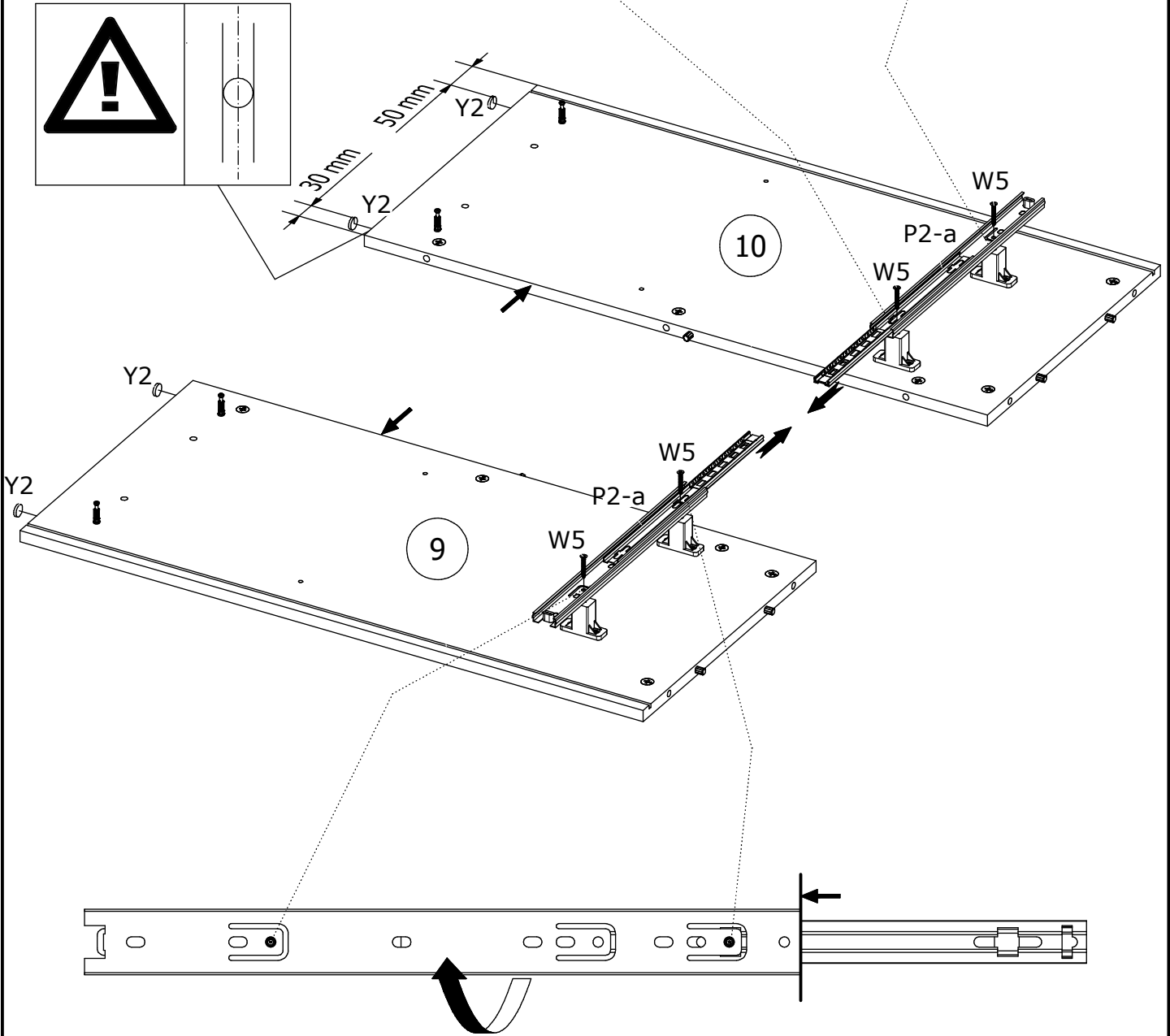
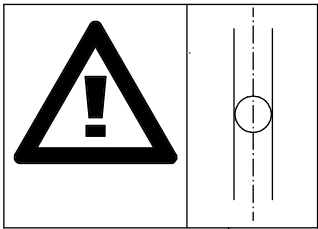
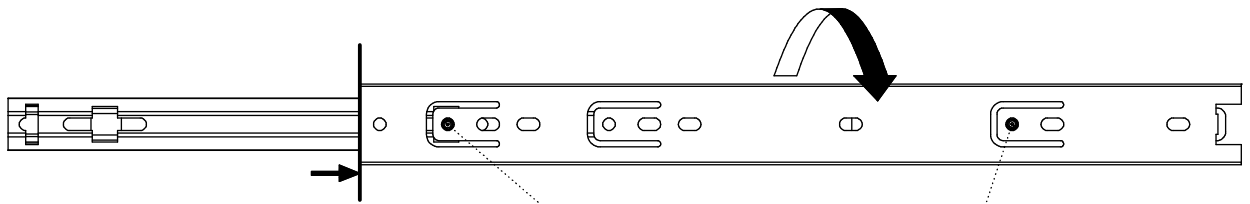
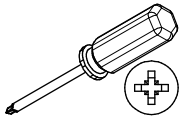
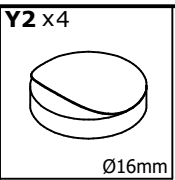
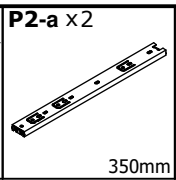
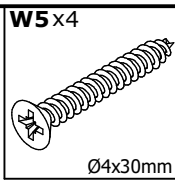

15

A1 x4

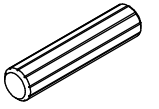

Ø8x35mm

C1 x4



Ø15x12mm

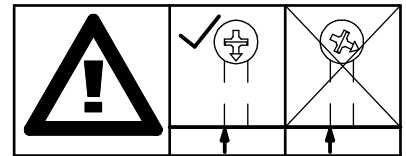
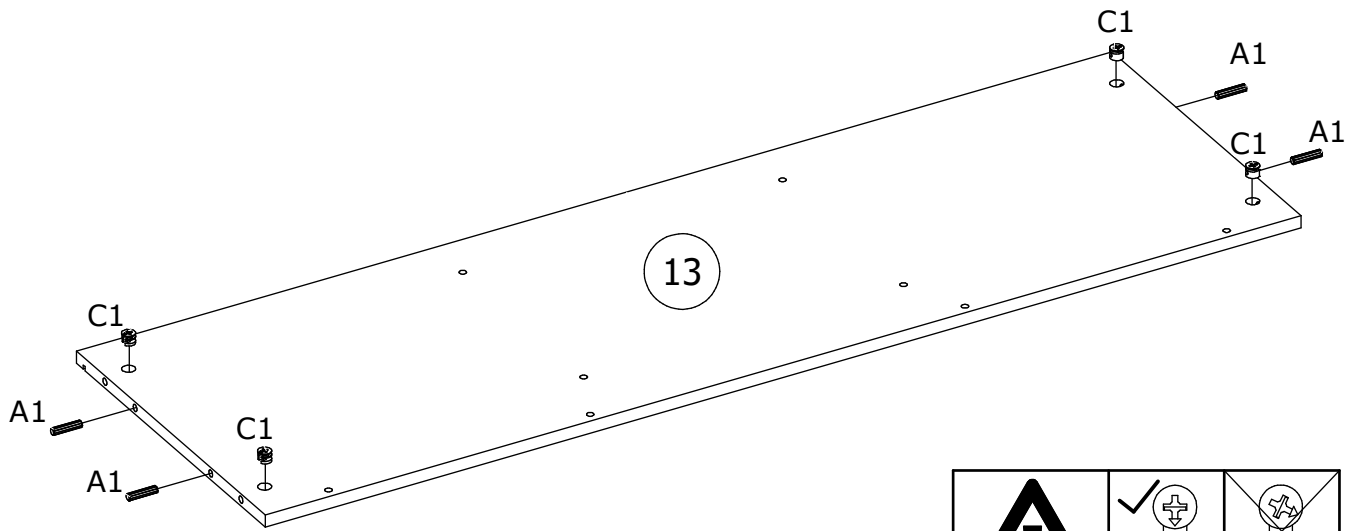
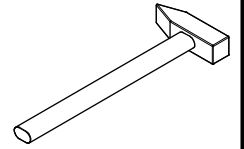

16

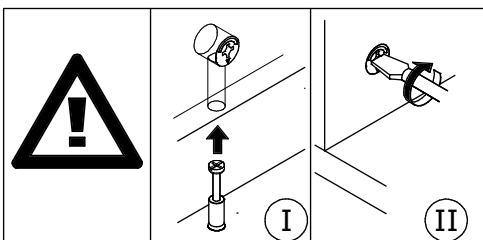
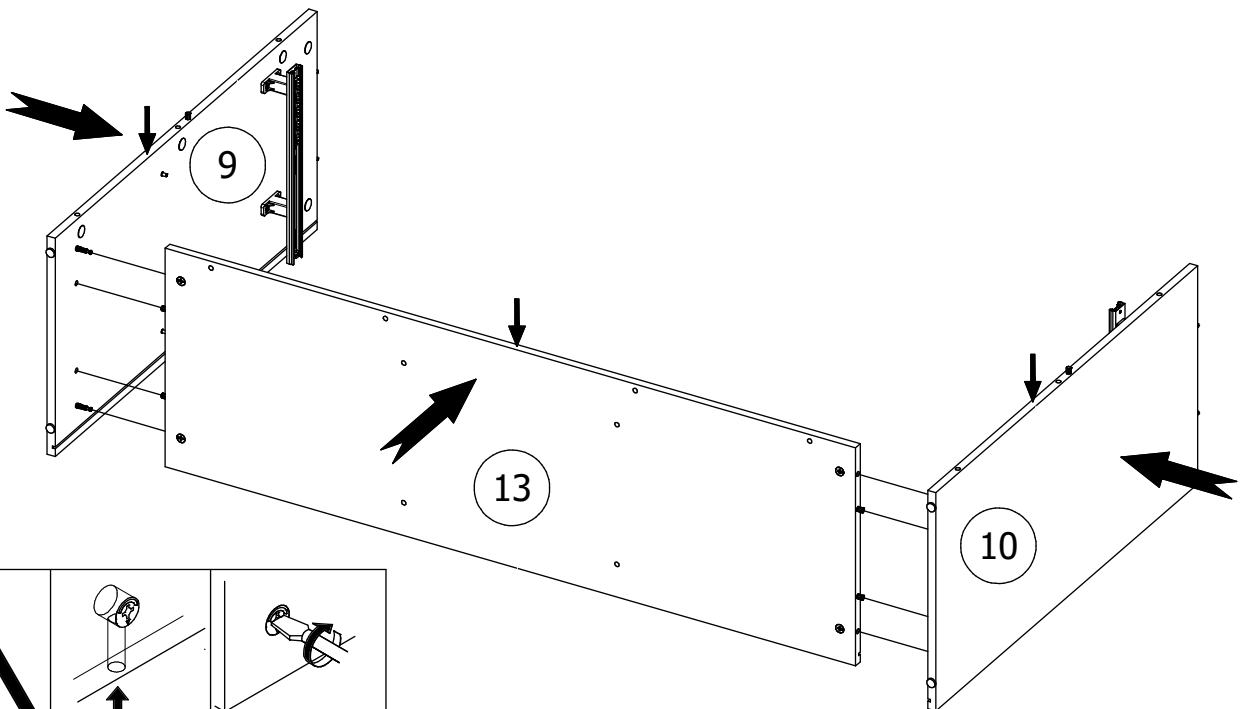
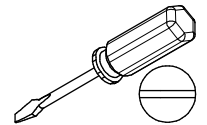

17

K1 x4

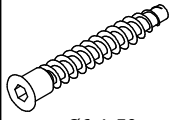

Ø6,4x50mm

N2x1



4mm HEX

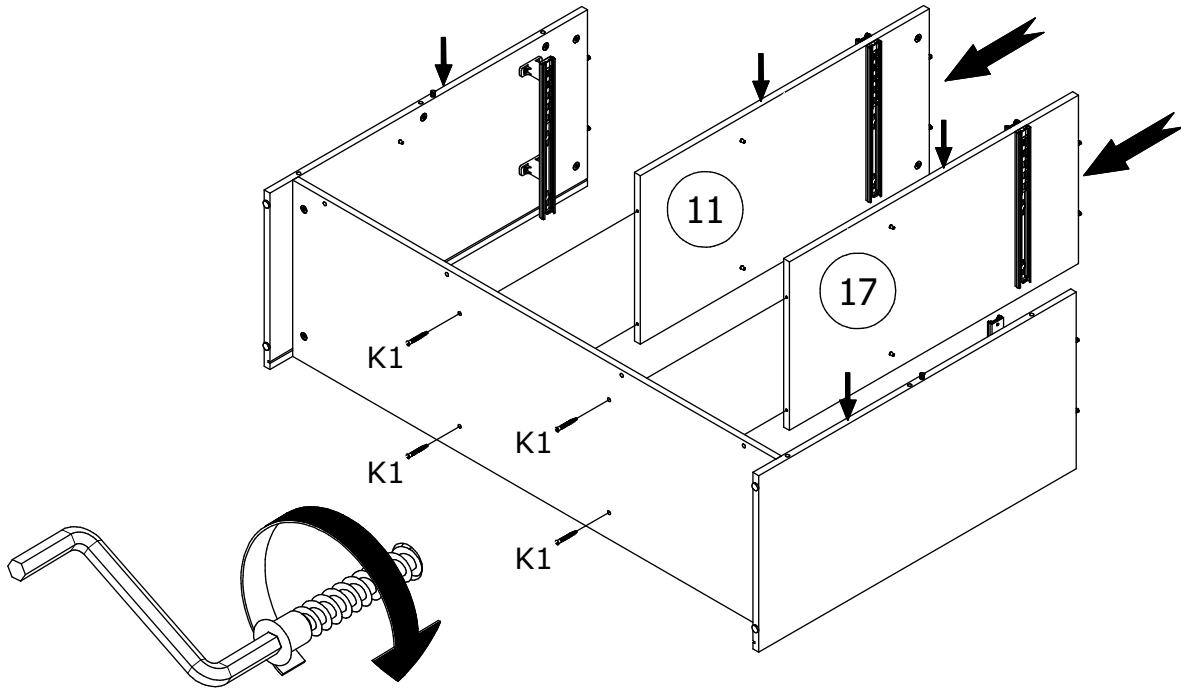

18

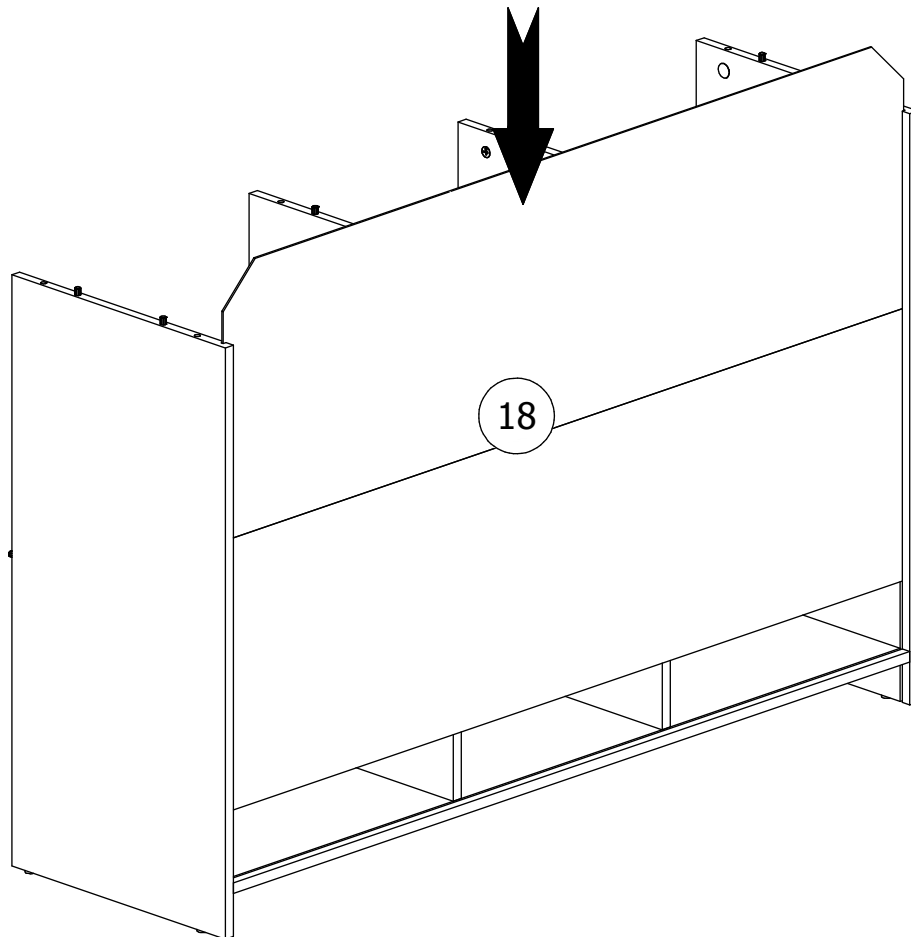

19

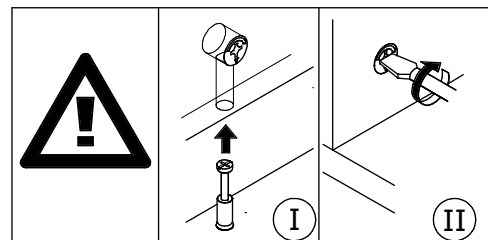
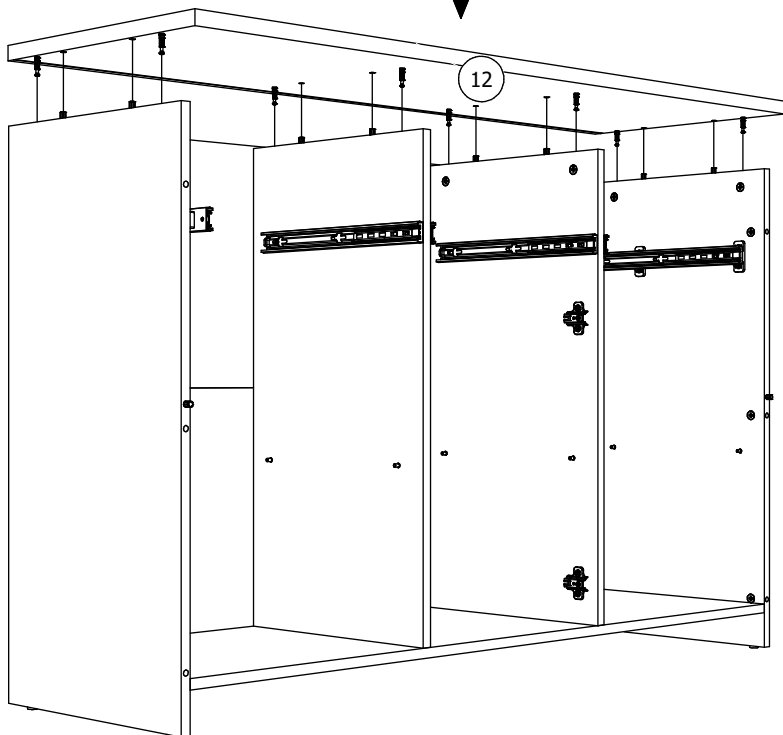
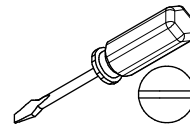

20

G2x18

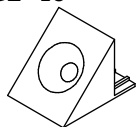

14x14mm

W2x18

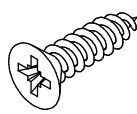

Ø3,5x16mm

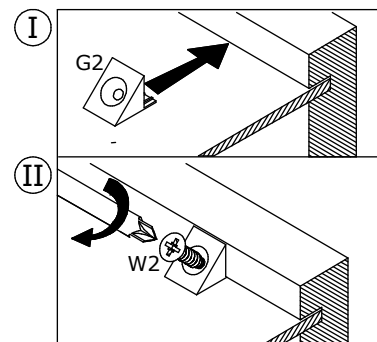
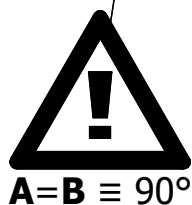
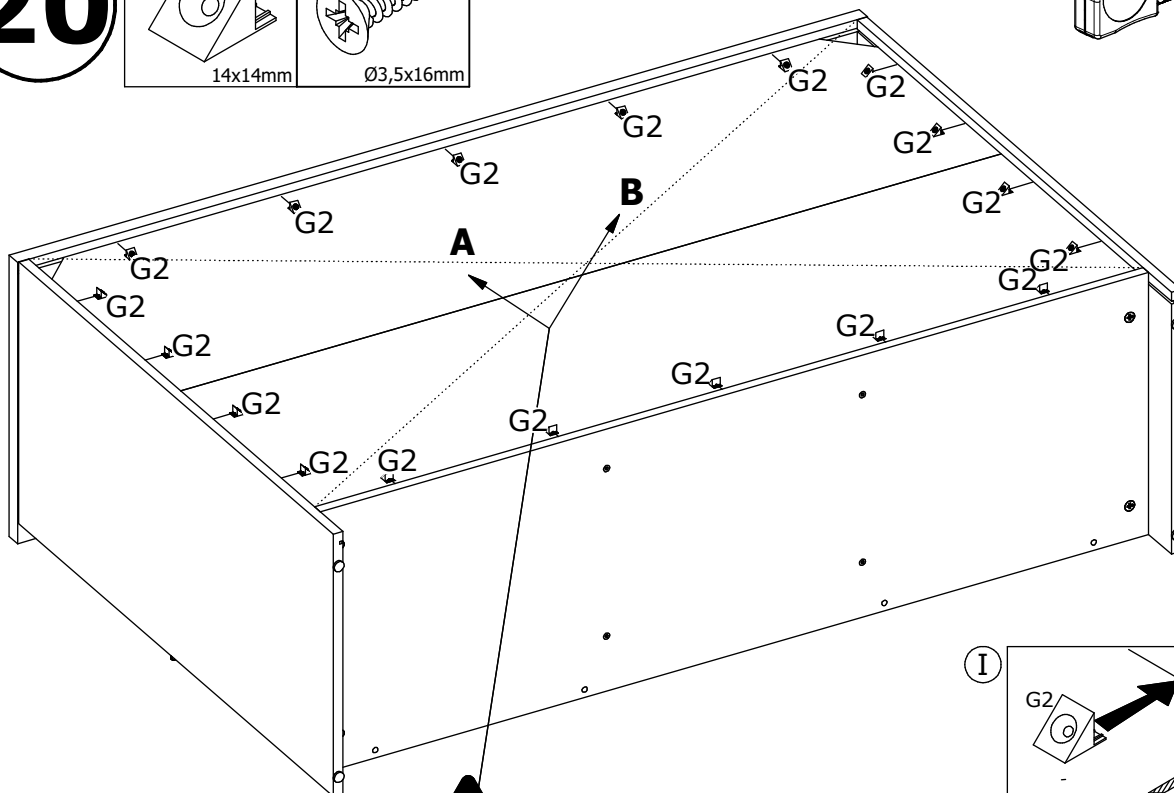
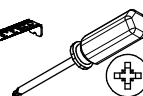
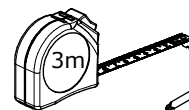

21

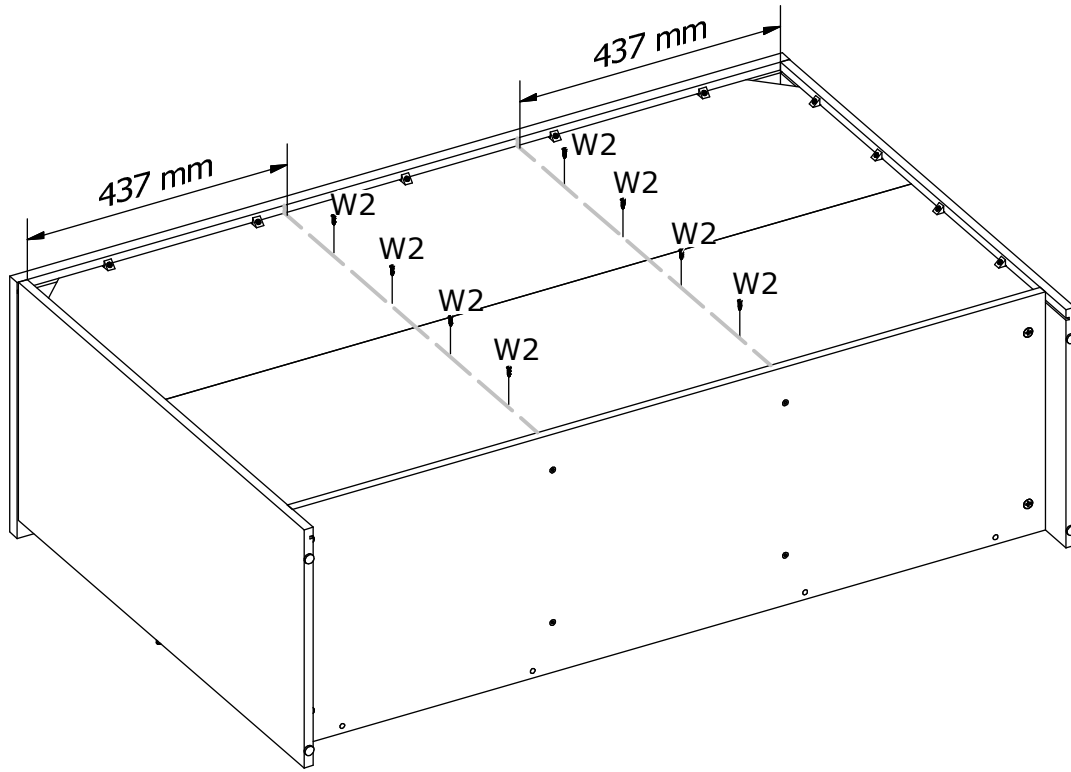
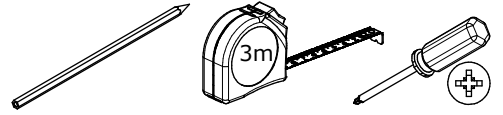
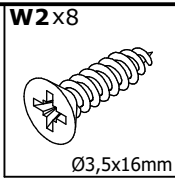

22

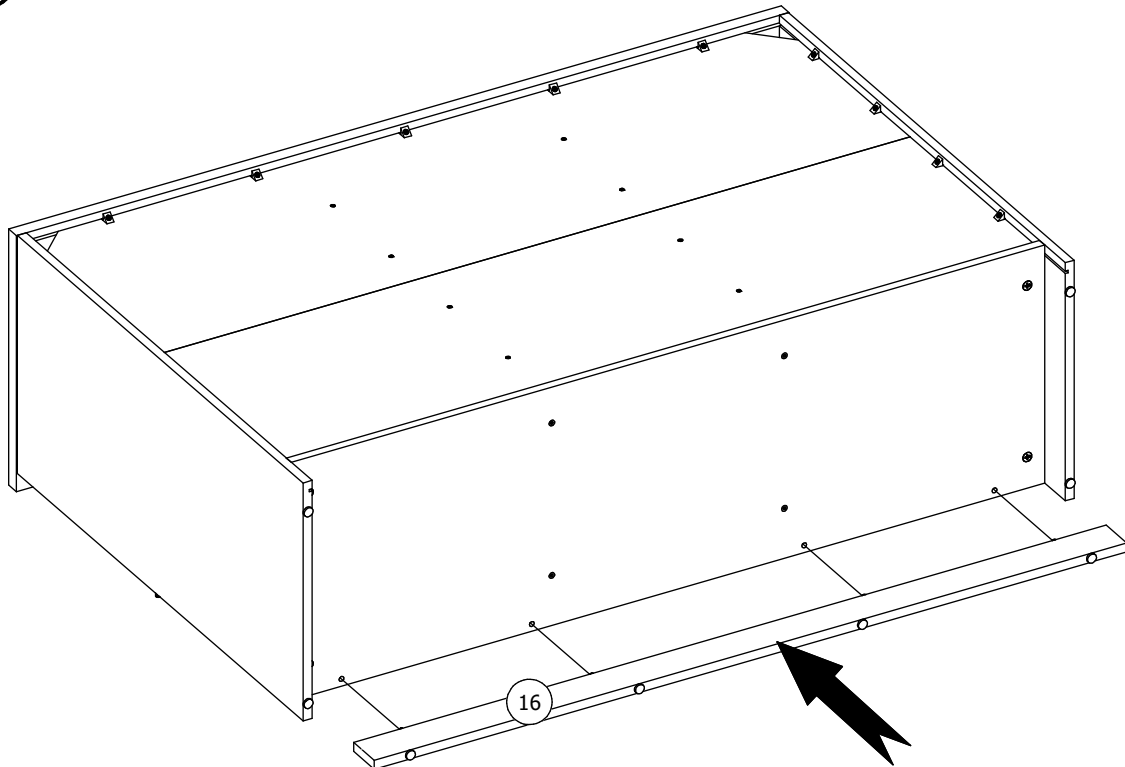

23

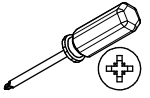
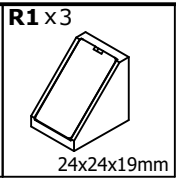
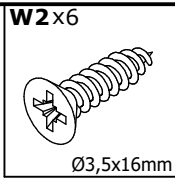

I

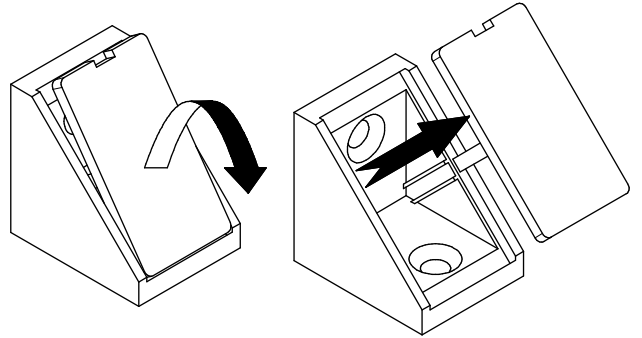

II

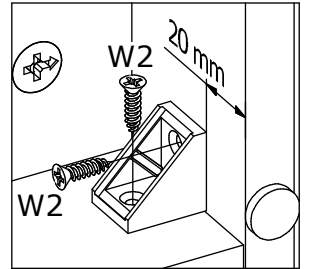
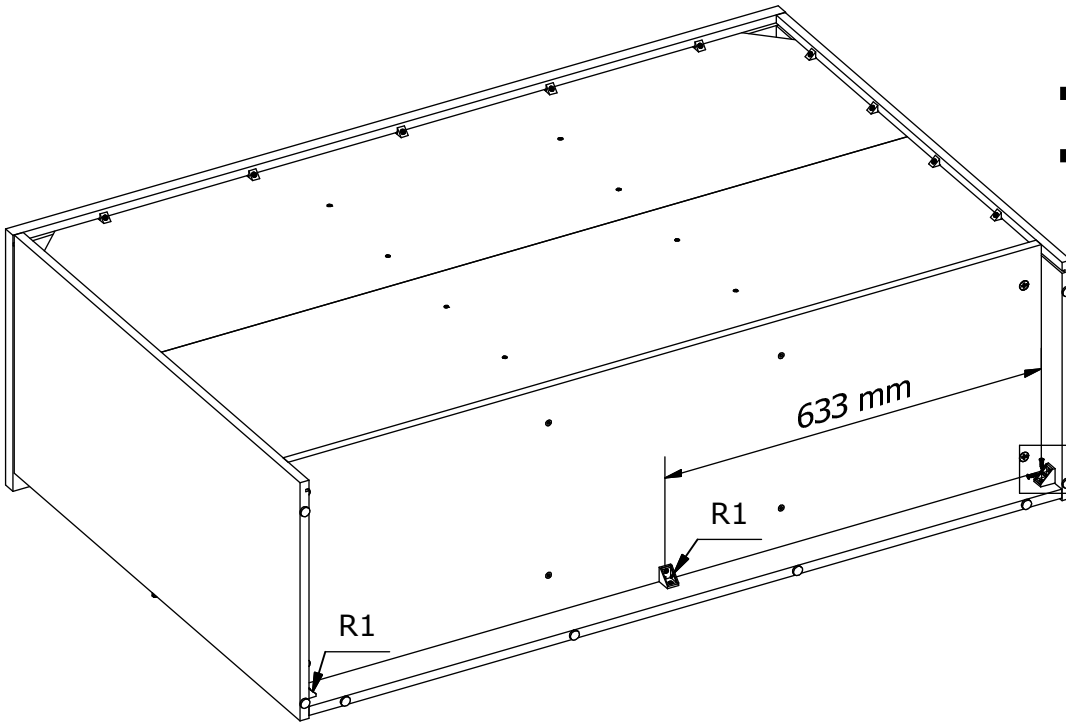

III

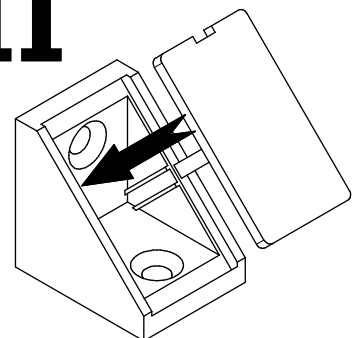

24

T1 x2

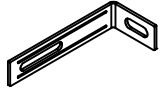

76x15mm

W2 x4

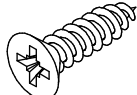

Ø3,5x16mm

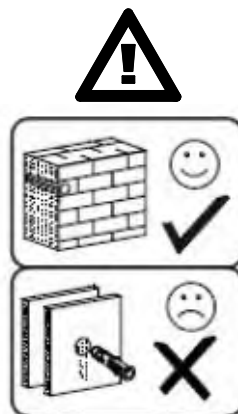
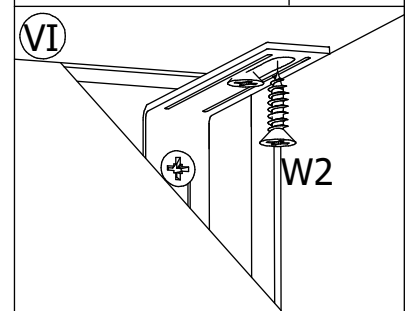
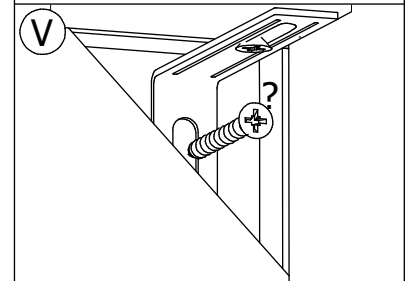
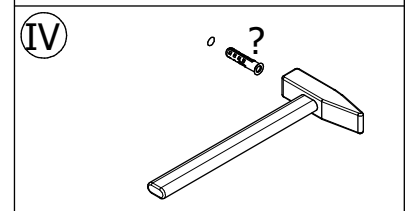
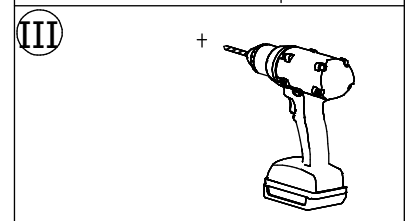
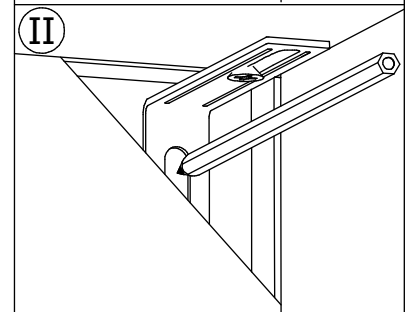
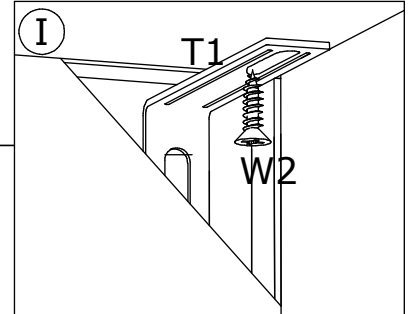
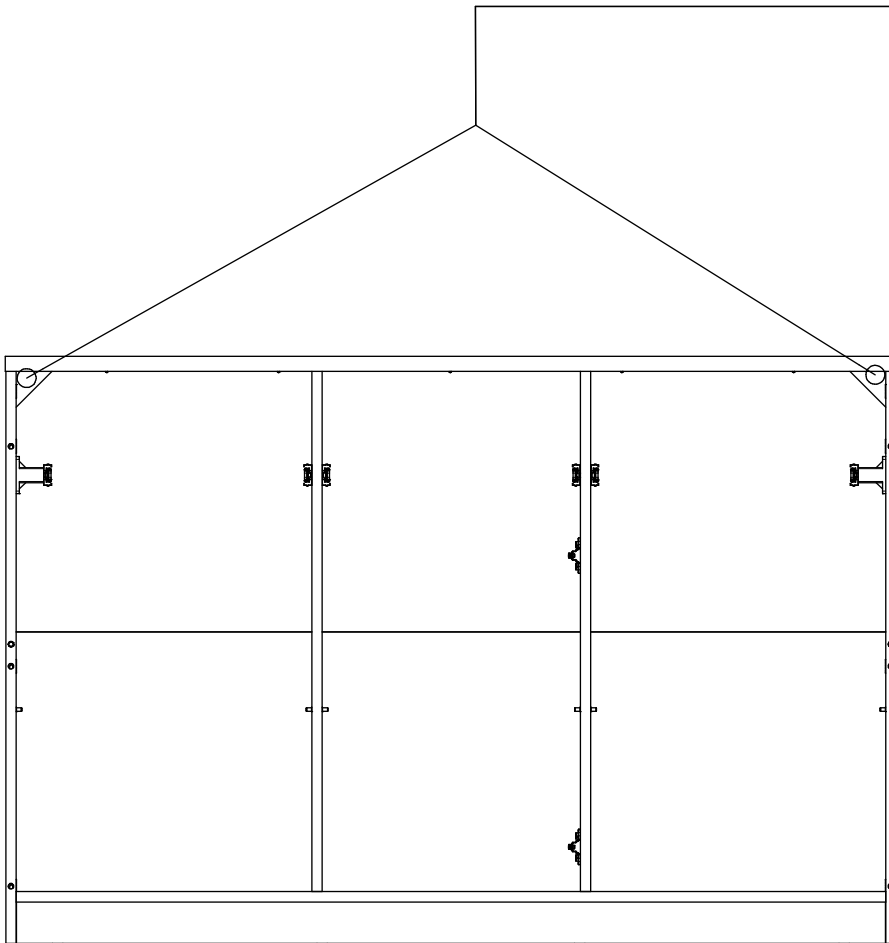
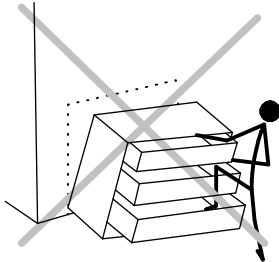
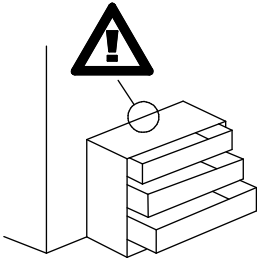
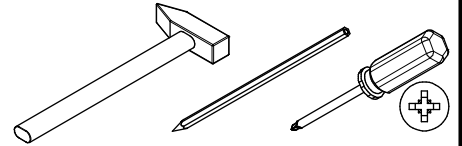

25

E1 x12

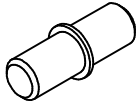

Ø5x16mm

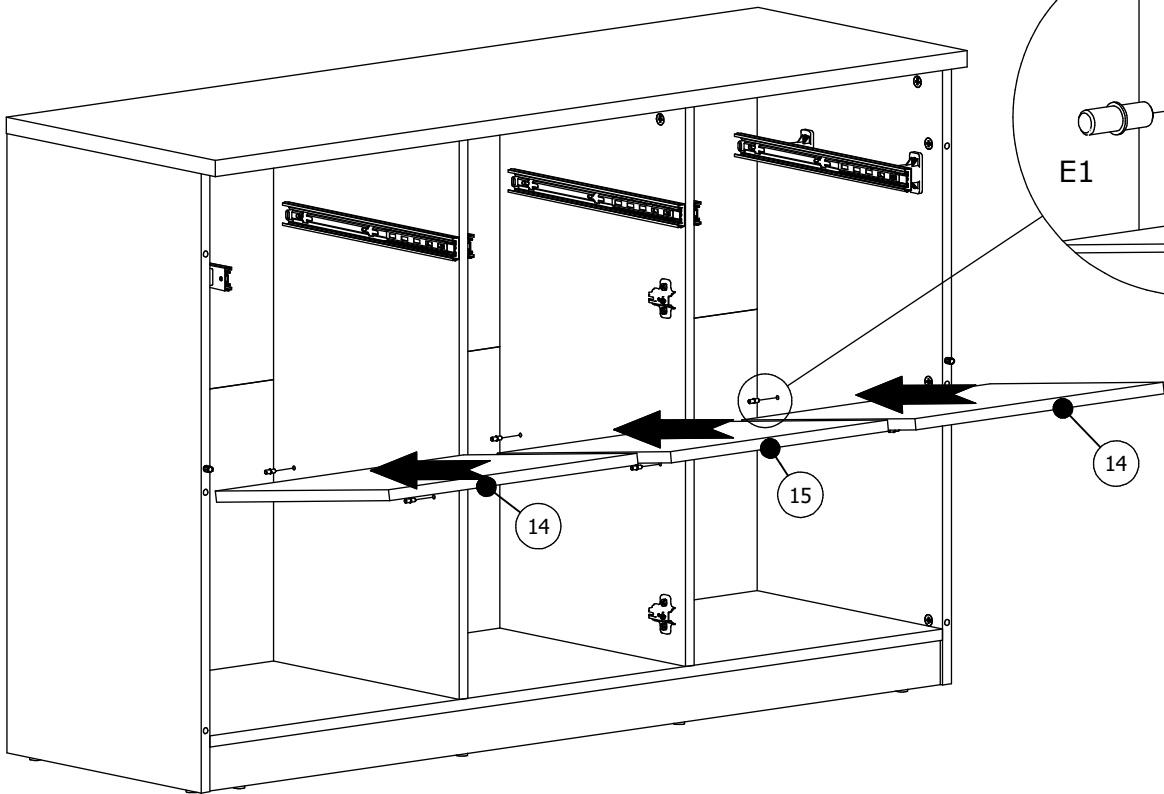

26

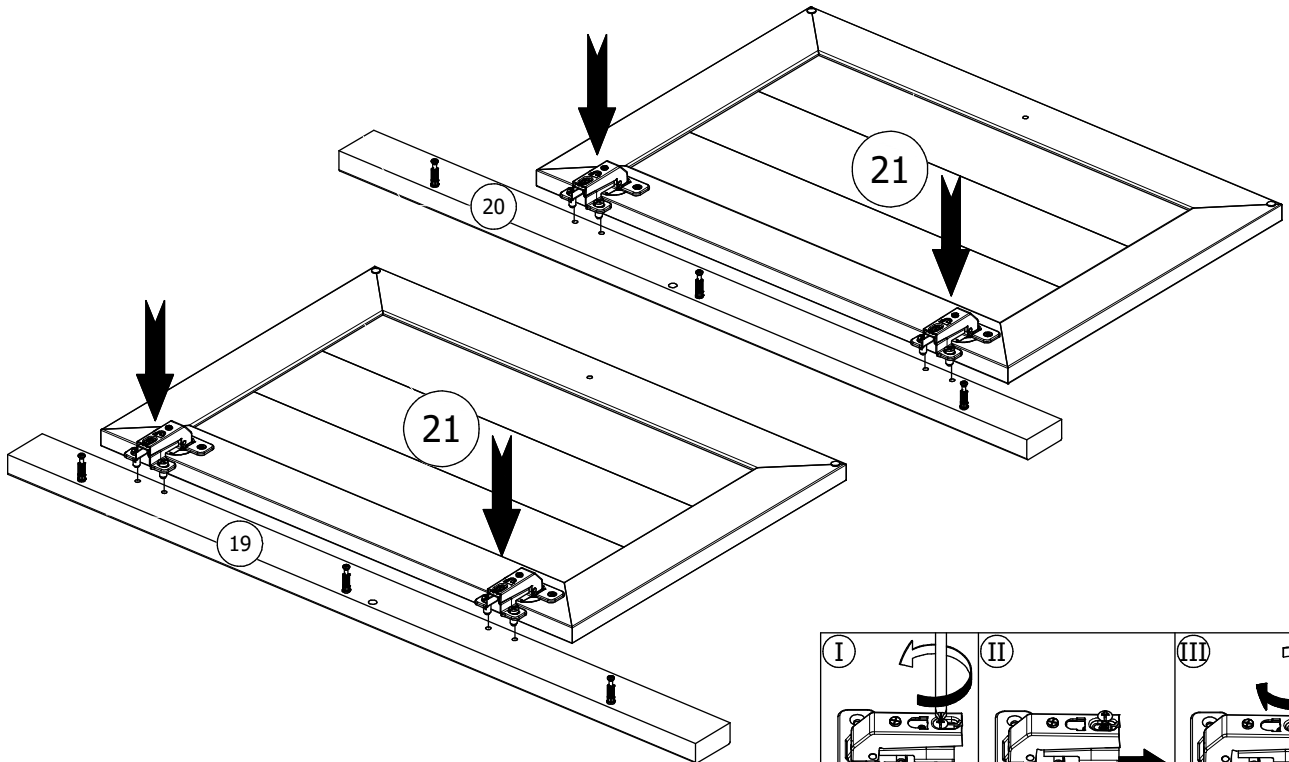
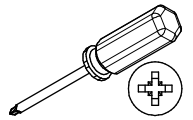

27

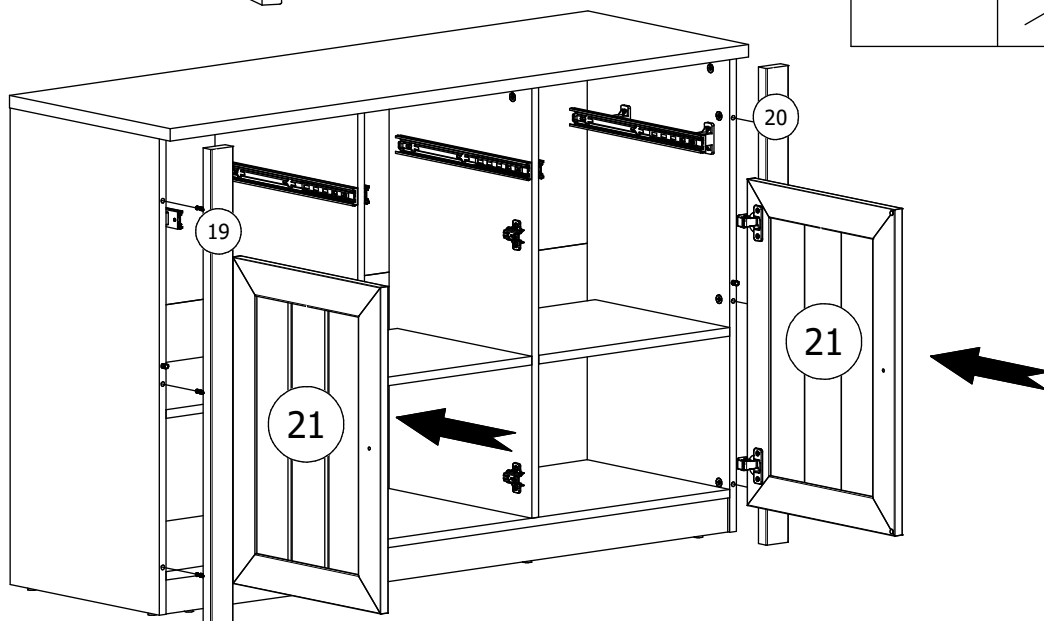
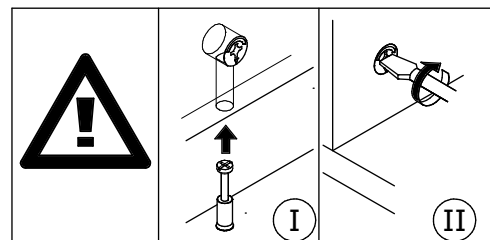
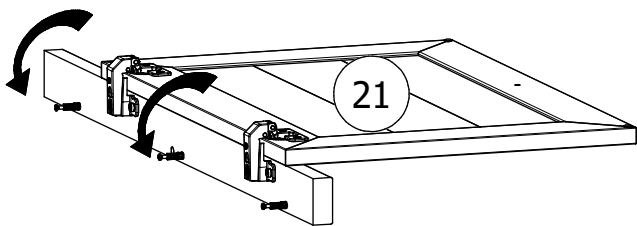
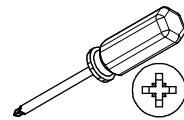

28

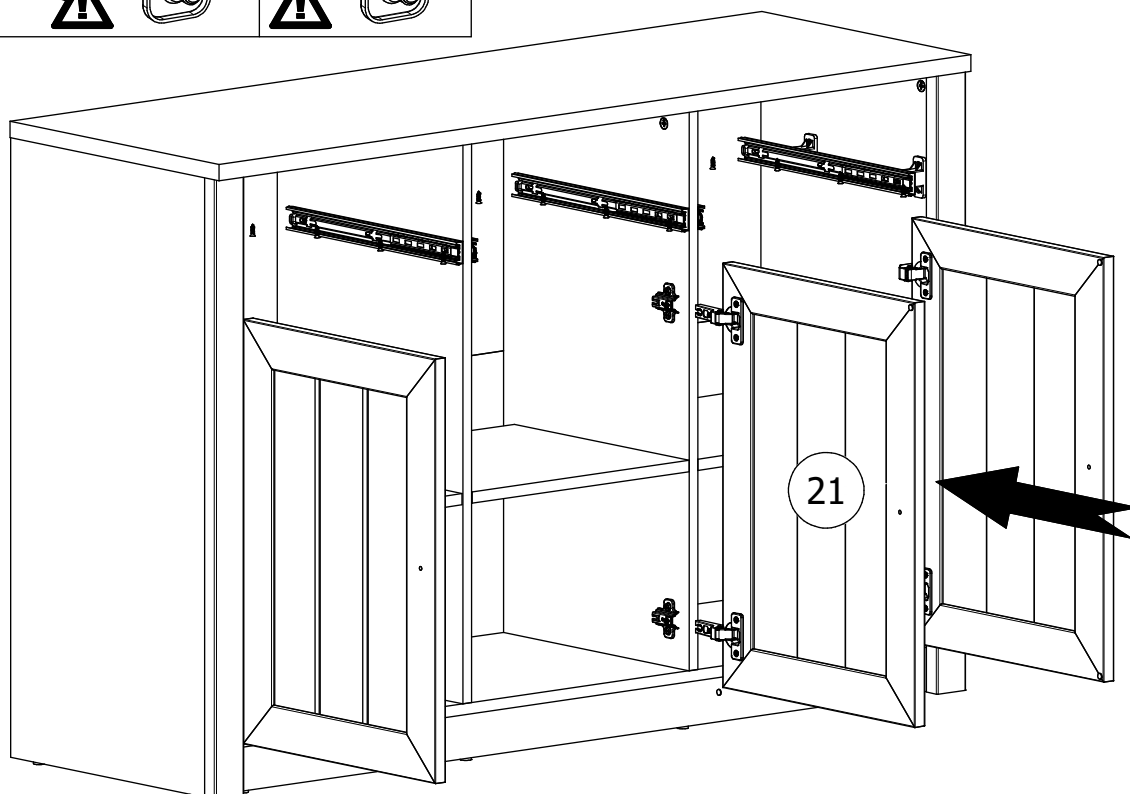
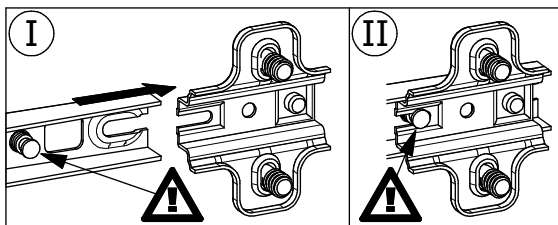
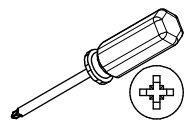

29

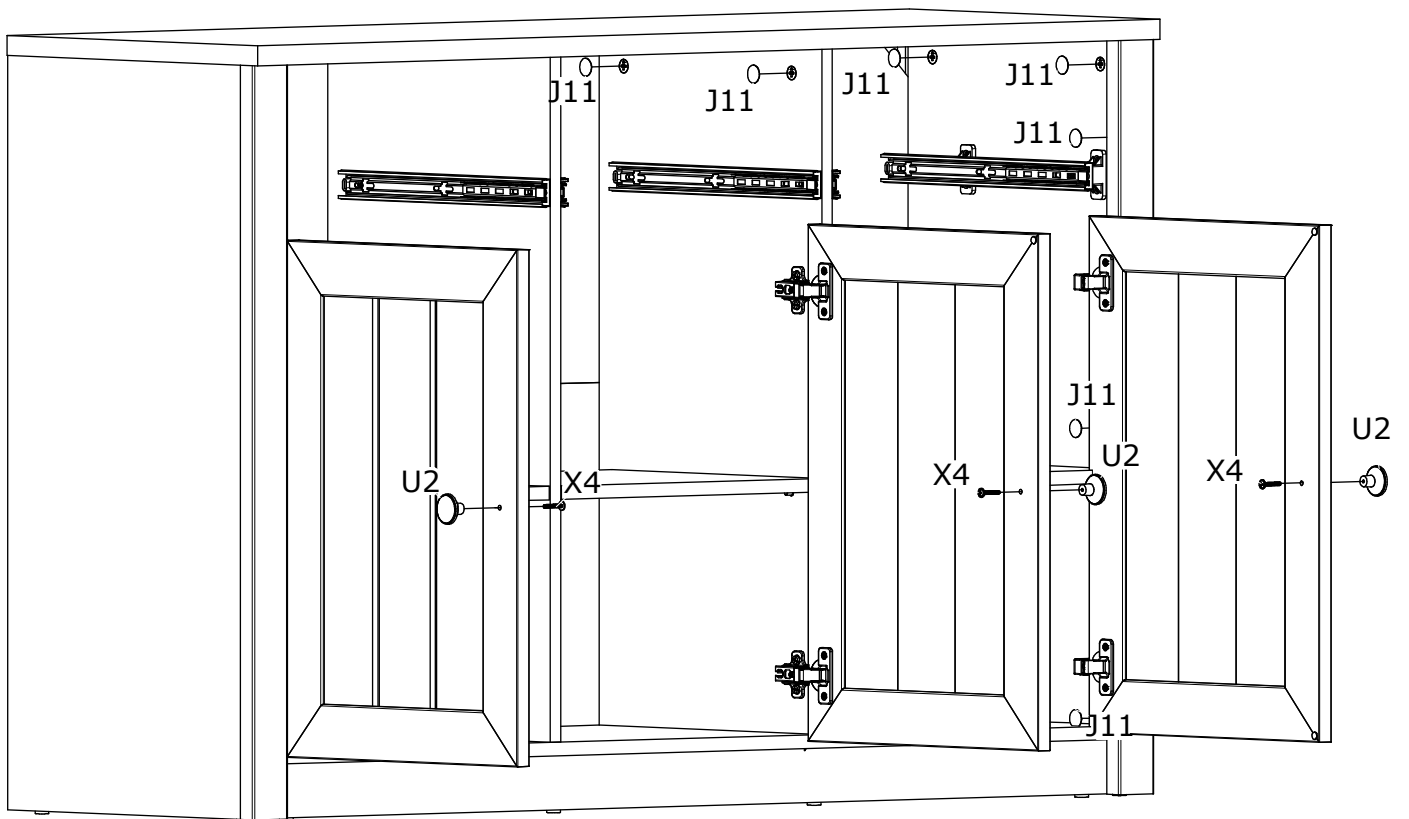
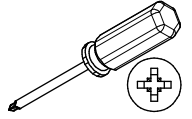
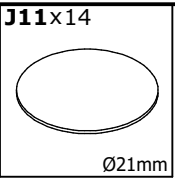
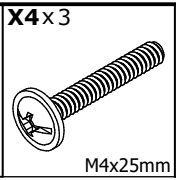
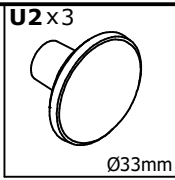

30

W2x6

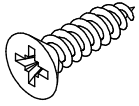

Ø3,5x16mm

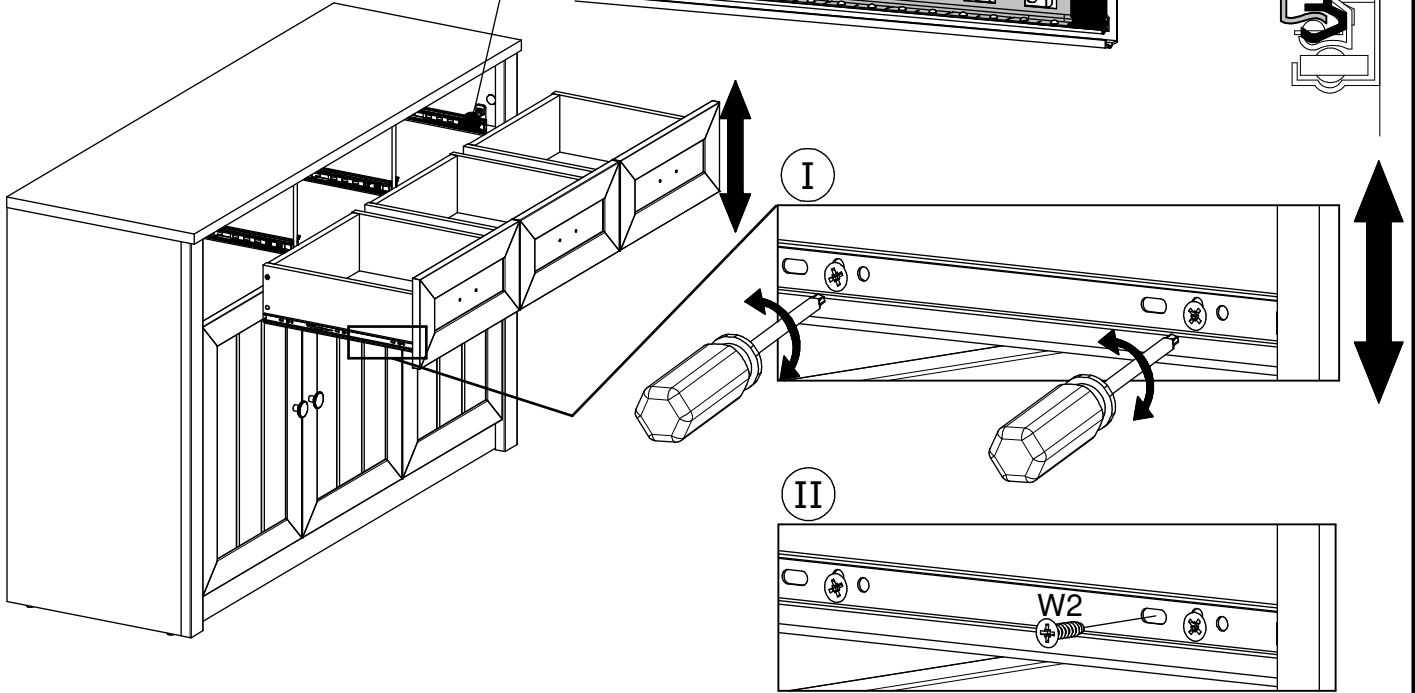
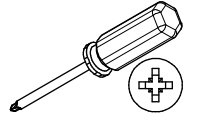
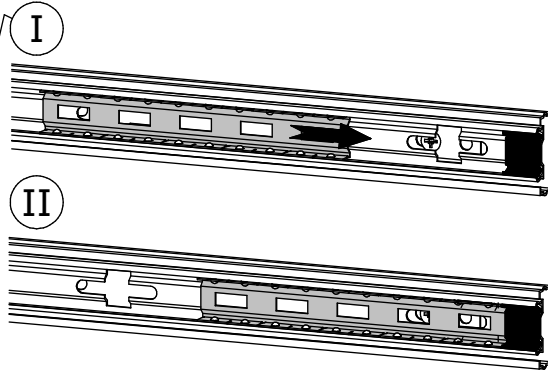

31

U4x3

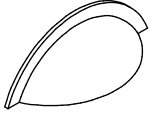

92x33mm

X2x6

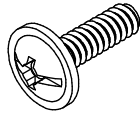

M4x16mm

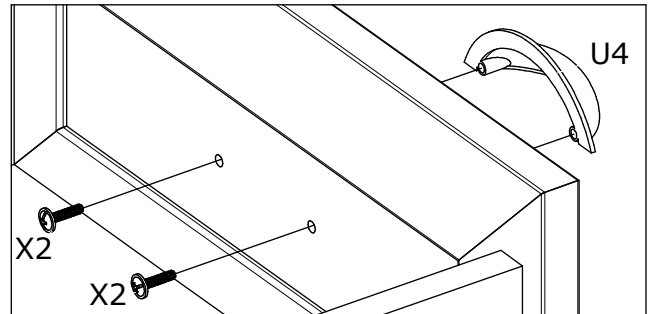
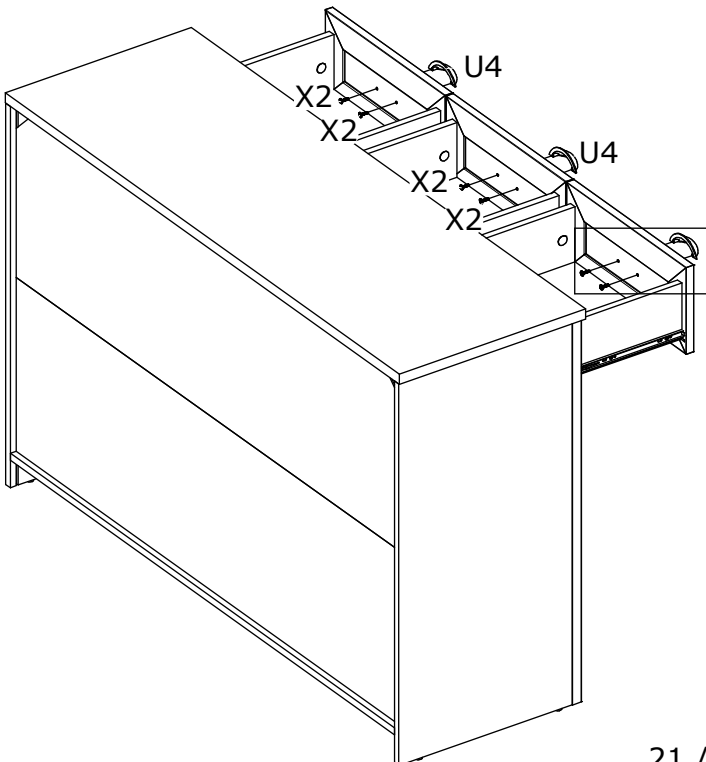
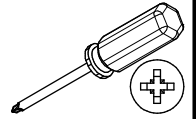

32

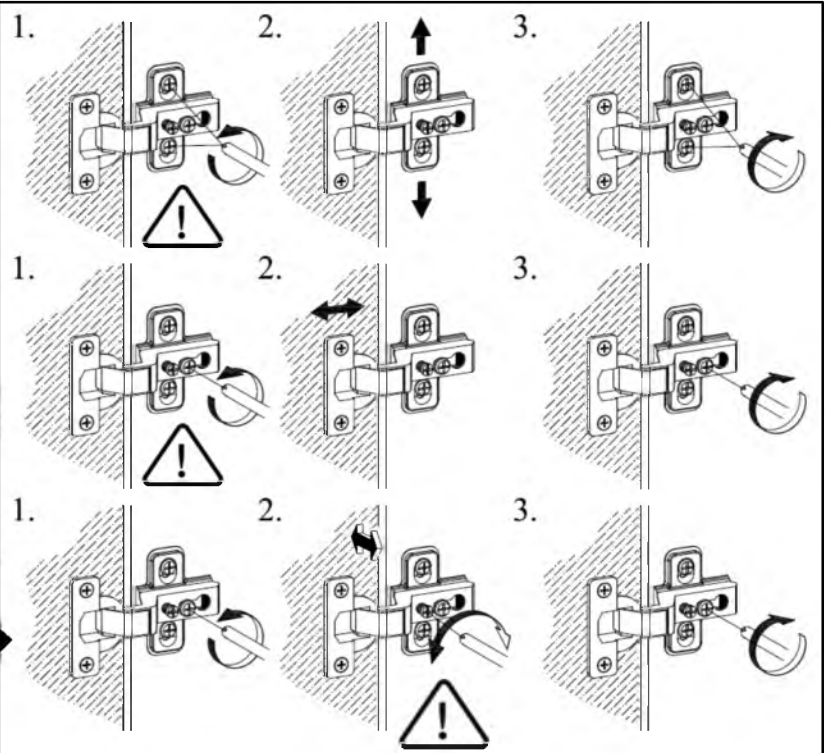
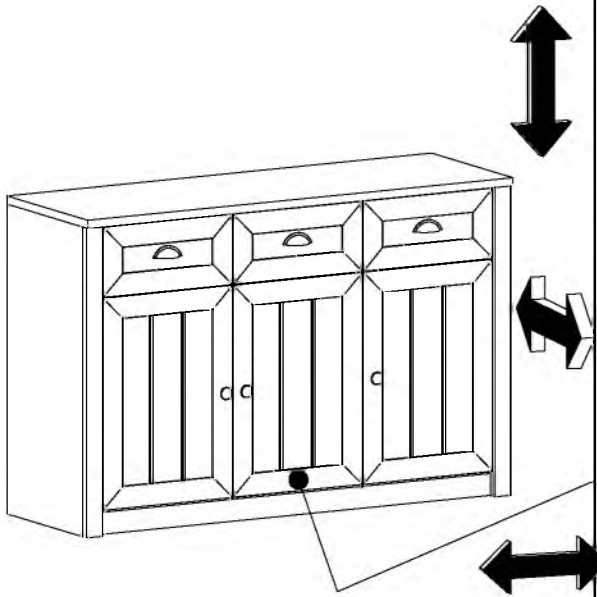
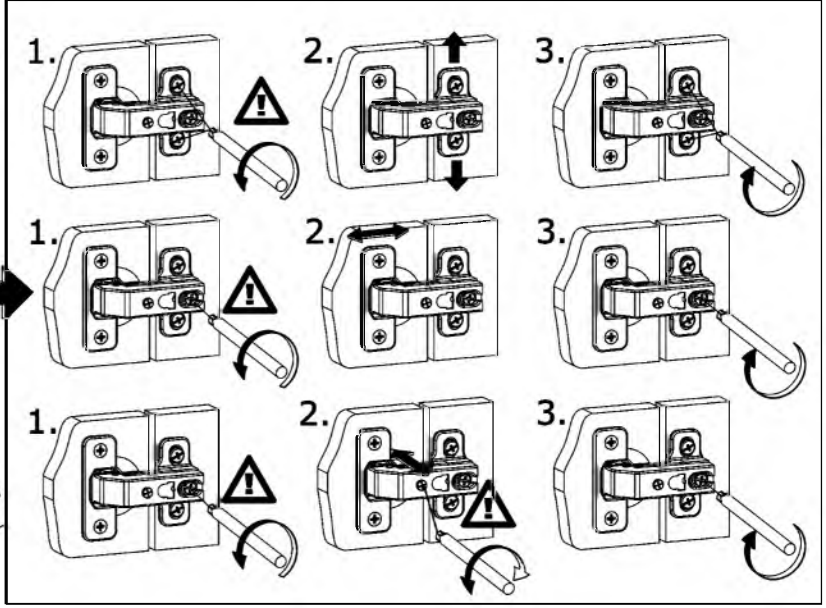
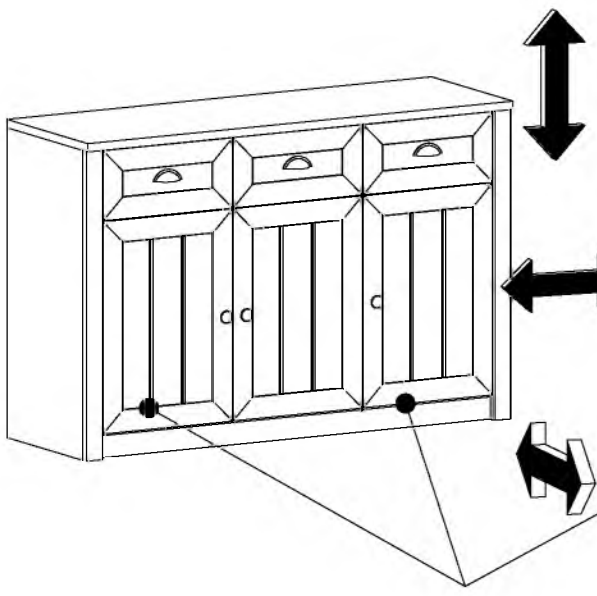

Name • Nom • Nome • Naam • Nazwa • Ἰσὲνο •
•Názov •Név • Denumire •Isim •Извание

Nr • No • N° • Номер • Č • Sz

Typ • Type • Tip • Τίπος • Тип • Tun

D

Unser Direktservice für Beschlagteile

Sollte Ihnen ein Beschlagteil fehlen, können Sie diese Servicekarte direkt an die untersahende Nummer senden. Wir können allerdings nur Beschlagteile auf diesem Weg verschicken. Sollen Sie eine andere Beanspruchung an Ihrem Möbelsstück haben, so wenden Sie sich bitte direkt an Ihr Möbelhaus.

GB

Our direct order service for fitting

If a fitting should be missing to you, you know this service map directly following number boxes. We can in this way send away however only fitting. If you should have another objection to your piece of furniture, then they turn please to your furniture house.

CZ

Naše přímé služby pro kování

Chybí-li vám nějaký díl z kování, můžete tuto servisní kartu odfaxovat přímo na níže uvedené číslo. Touto cestou však můžeme zaslát jen díly kování. Pokud byste reklamovali jiný díl nábytku, obraťte se přímo na svého prodejce nábytku.

F

Bien étudier la notice de montage

Repérez les pièces constituant votre meuble. Regroupez et contrôlez la quincaillerie. Munissez-vous de l'outillage nécessaire. Aménagez-vous une zone de montage. Procédez au montage. Ne jamais forcer les assemblages. Resserrez les vis après quelques temps d'usage. Garder votre notice de montage, si une pièce venait à manquer, elle serait le plus clair moyen de communiquer avec votre magasin.

I

Il nostro servizio diretto per l'ordine della ferramenta

Nel caso vi mancherà del pezzo, potete spedire questa carta di servizi direttamente al seguente numero. Per altri reclami al vostro mobile, potete rivolgervi al vostro mobilificio.

BG

Директно обслуженије на фиделитетни делови

Ако вам нешто недостаје од делова мобила, можете послати ову сервисну картицу директно на доле наведено број. Овај начин може само послати делове мобила. Ако имате друге претензије на ваш мобил, обратите се директно на ваш трговински покривач.

NL

Onze directservice voor losse onderdelen

Wanneer er een onderdeel mist kunt u deze servicekaart direct aan onderstaand faxnummer sturen. Wij kunnen alleen langs deze weg onderdelen versturen. Mocht u een ander probleem aan uw meubel hebben verzoeken wij u contact op te nemen met uw meubeldealer.

PL

Nasz bezpośredni serwis części montażowych

Jeżeli brakuje części koniecznych do montażu, prosimy o przesłanie nam tej karty serwisowej na niżej podany numer faxu. Możemy w ten sposób przysłać jedynie te części, których brakujemy. W przypadku innych objętości dotyczących mebla, prosimy o zgłoszenie ich do salonu meblowego w którym został dokonany zakup.

HR

Servis za okove

U slučaju da nedostaje neki od dijelova molimo vas da na dolje nevedeni broj posaljete ovaj servisni obrazac. Na ovaj način mogu se dostaviti samo okovi. U slučaju da imate dodatne prigovore vezane uz komad namještaja molimo vas da se obratite izravno trgovini namještaja gdje je isti kupljen.

HU

Direktszoállításunk vészetek esetén

Ha hiányzik egy vészet, ezt a kártyát közvetlenül elfaxolhatja az alább található faxszámra. Azonban csak a vészeteket tudunk így küldeni. Amennyiben másfajta reklamáció áll fenn bútorrészegyekkel szemben, forduljon közvetlenül a bútorháznál.

SK

Naše priamy servis pre časti kovania

Ak by Vám chýbala nejaká časť kovania, môžete poslať túto servisnú kartu poslať faxom priamo na nižšie uvedené číslo. Díly kovania vieme poslať iba týmto spôsobom. Ak by ste mali inú reklamáciu ohľadom Vášho nábytku, obraťte sa priamo na Vašu predajnú nábytku.

SLO

Naše direktno služne storitve za okovje

Ce vam manjka kakšno okovje, lahko to serviso kartico pošljete po faxu direktno na spodnjo številko. Po tej poti vam lahko pošljemo samo okovje. Če želite reklamirati kakšen drug del pohištva, se obrnite neposredno na vašo trgovino pohištva.

RO

Service-ul nostru direct pentru feronerie

În cazul în care vă lipsește o piesă de feronerie puteți să trimiteți direct această card de service pe fax la numărul de mai jos. Noi nu putem expedia piese de feronerie decât pe această cale. Dacă aveți o altă reclamație referitoare la piesa de mobilier, atunci vă rugăm să vă adresați direct la magazinul dvs. de mobilă.

RUS

Наш прямой сервис для поставок фурнитуры

Если окажется, что Вам не хватает того или иного элемента фурнитуры, Вы можете отправить сервисную карту по факсу непосредственно на нижеприведенный номер. Однако, таким образом мы можем переслать лишь фурнитуру. Если же у Вас возникнут иные претензии относительно приобретенной мебели, пожалуйста, обращайтесь непосредственно в организацию, осуществлявшую продажу.

S

Vår direktservice för beslagdelar

Om du saknar en beslagdel kan du faxa detta servicekort direkt till numret som anges ned. Tänk på att detta är den enda möjligheten att skicka beslagdelar till dig. Om du vill reklamera din möbel av en annan anledning måste du kontakta ditt möbelhus direkt.

ES





Nuestro servicio directo para accesorios

Si le falta algún accesorio, puede enviar esta tarjeta de servicio directamente a la siguiente dirección. No obstante, por este método solo podemos enviar accesorios. Si tiene alguna otra objeción sobre su mueble, consulte directamente con su mueblería.

TR

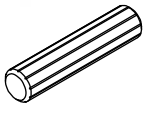
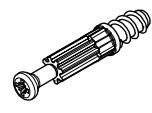
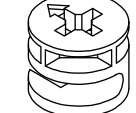
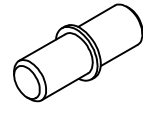
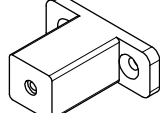
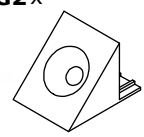
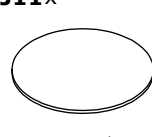
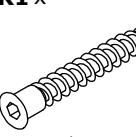
Donatılar için doğrudan servisimiz

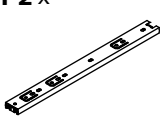
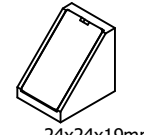
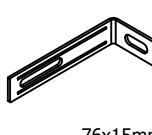
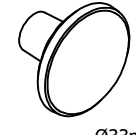
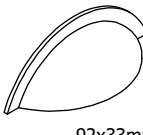
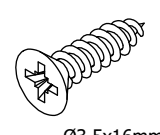
Bir donatınız eksikse bu servis kartını doğrudan aşağıda bulunan adrese doğrudan mail yazabilirsiniz. Sadece bu yolla donatıları gönderebiliriz. Mobilyanızda başka şikayetleriniz varsa lütfen doğrudan mobilya satıcınıza danışın.

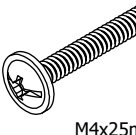
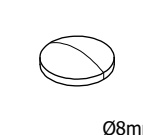
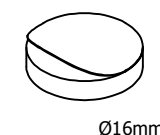
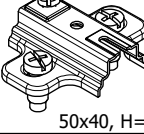
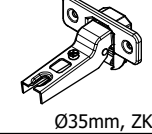
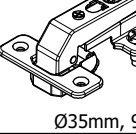
A1 x  Ø8x35mm	B1 x  Ø5x38mm	C1 x  Ø15x12mm	E1 x  Ø5x16mm	F2 x  40mm
G2 x  14x14mm	J11 x  Ø21mm	K1 x  Ø6,4x50mm	N2 x  4mm HEX	P2 x  350mm
R1 x  24x24x19mm	T1 x  76x15mm	U2 x  Ø33mm	U4 x  92x33mm	W2 x  Ø3,5x16mm
W5 x  Ø4x30mm	X2 x  M4x16mm	X4 x  M4x25mm	Y1 x  Ø8mm	Y2 x  Ø16mm
Z1 x  50x40, H=2	Z4 x  Ø35mm, ZK9	Z6 x  Ø35mm, 90°		



Name • Nom • Nome • Naam • Nazwa • Όνομα
• Názov • Név • Denumire • Isim • Имя

Nr • No • N° • Номер • Č • Sz

Typ • Type • Tip • Típus • Tipo • Tur

— —

D

Unser Direktservice für Beschädigte
Sollte Ihnen ein Beschädigter fehlen, können Sie diese Servicekarte direkt an die untenstehende Nummer senden. Wir können allerdings nur Beschädigte auf diesem Weg verschicken. Sollen Sie eine andere Beanstandung an Ihrem Möbelsstück haben, so wenden Sie sich bitte direkt an Ihr Möbelhaus.

GB

Our direct order service for fitting
If a fitting should be missing to you, you know this service map directly following number boxes. We can in this way send away however only fitting. If you should have another objection to your piece of furniture, then they turn please to your furniture house.

CZ

Naše přímé služby pro kování
Chybí-li vám nějaký díl z kování, můžete tuto servisní kartu odfaxovat přímo na níže uvedené číslo. Touto cestou však můžeme zaslát jen díly kování. Pokud byste reklamovali jiný díl nábytku, obraťte se přímo na svého prodejce nábytku.

F

Bien étudier la notice de montage
Repérez les pièces constituant votre meuble. Regroupez et contrôlez la quincaillerie. Munissez-vous de l'outillage nécessaire. Aménagez-vous une zone de montage. Procédez au montage. Ne jamais forcer les assemblages. Resserrez les vis après quelques temps d'usage. Garder votre notice de montage, si une pièce venait à manquer, elle serait le plus clair moyen de communiquer avec votre magasin.

I

Il nostro servizio diretto per l'ordine della ferramenta
Nel caso vi mancassero dei pezzi, potete spedire fax questa carta di servizio direttamente al seguente numero. Per altri reclami al vostro mobile, potete rivolgervi al vostro mobilificio.

BG

Директно обслужити не събитите отули "Обзор"
Ако ви липне некои дел од кованието, можете директно да испратите оваа сервисна картичка на адресот подолу. Можеме да ви испратим само делови од кованието. Ако имате друга забелешка за вашиот мебел, молиме да се обратите директно на вашиот продавач на мебел.

NL

Onze directservice voor losse onderdelen
Wanneer er een onderdeel mist kunt u deze servicekaart direct aan onderstaand faxnummer sturen. Wij kunnen alleen langs deze weg onderdelen versturen. Mocht u een ander probleem aan uw meubel hebben verzaken wij u contact op te nemen met uw meubeldealer.

PL

Nasz bezpośredni serwis części montażowych
Jeżeli brakuje części koniecznych do montażu, prosimy o przesłanie nam tej karty serwisowej na niżej podany numer faxu. Możemy w ten sposób przysłać państwu tylko brakujące części. W przypadku innych obiekcyj dotyczących mebla, prosimy o zgłoszenie ich do salonu meblowego w którym został dokonany zakup.

HR

Servis za okove
U slučaju da nedostaje neki od dijelova molimo vas da na dalje nevedeni Fax broj posaljete ovaj servisni obrazac. Na ovaj način mogu se dostaviti samo okovi. U slučaju da imate dodatne prigovore vezane uz komad namještaja molimo vas da se obratite izravno trgovini namještaja gdje je isti kupljen.

HU

Direktszolgálatunk vesztlak esetén
Ha hiányzik egy vesztlak, ezt a kártyát közvetlenül elfaxolhatja az alább található faxszámra. Azonban csak a vesztlakokat tudunk így küldeni. Amennyiben másfajta reklamációt áll fenn bűtorárábját illetően, forduljon közvetlenül a bűtorházhoz.

SK

Naše priamy servis pre besit kovania
Ak by Vám chýbala nejaká časť kovania, môžete poslať túto servisnú kartu poslať faxom priamo na nižšie uvedené faxové číslo. Diely kovania vieme poslať iba týmto spôsobom. Ak by ste mali inú reklamáciu ohľadom Vášho nábytku, obráťte sa priamo na Vašu predajnú nábytku.

SLO

Naše direktne služne storitve za okovje
Ce vam manjka kakšno okovje, lahko to servisno kartico pošljete po faxu direktno na spodnjo številko. Po tej poti vam lahko pošljemo samo okovje. Če želite reklamirati kakšen drug del pohištva, se obrnite neposredno na vašo trgovino pohištva.

RO

Service-ul nostru direct pentru fieronerie
In cazul in care va lipsesc o piesa de fieronerie puteti sa trimitemi direct acest card de service pe fax la numarul de mai jos. Noi nu putem expedia piese de fieronerie decat pe acestul cale. Decit aveți o altă reclamație referitoare la piese de mobilier, atunci vă rugăm să vă adresați direct la magazinul dvs. de mobilă.

RUS

Наш прямой сервис для поставок фурнитуры
Если окажется, что Вам не хватает того или иного элемента фурнитуры, Вы можете отправить сервисную карту по Факсу непосредственно на нижеприведенный номер. Однако, таким образом мы можем переслать лишь фурнитуру. Если же у Вас возникнут иные претензии относительно приобретенной мебели, пожалуйста, обращайтесь непосредственно в организацию, осуществляющую продажу.

S

Vår directservice för beslagdelar
Om du saknar en beslagdel kan du faxa detta servicekort direkt till numret som anges ned. Tänk på att detta är den enda möjligheten att skicka beslagdelar till dig. Om du vill reklamera din möbel av en annan anledning måste du kontakta ditt möbels hus direkt.

ES

Nuestro servicio directo para accesorios
Si le falta algún accesorio, puede enviar esta tarjeta de servicio directamente a la siguiente dirección. No obstante, por esta vía sólo podemos enviar accesorios. Si tiene alguna otra objeción sobre su mueble, consulte directamente con su mueblería.

TR

Donatilar için doğrudan servisimiz
Bir donatınız eksikse bu servis kartını doğrudan aşağıda bulunan adrese doğrudan mail yazabilirsiniz. Sadece bu yolla donatılar gönderiliriz. Mobilyanızda başka şikayetiniz varsa lütfen doğrudan mobilya satışınıza danışın.

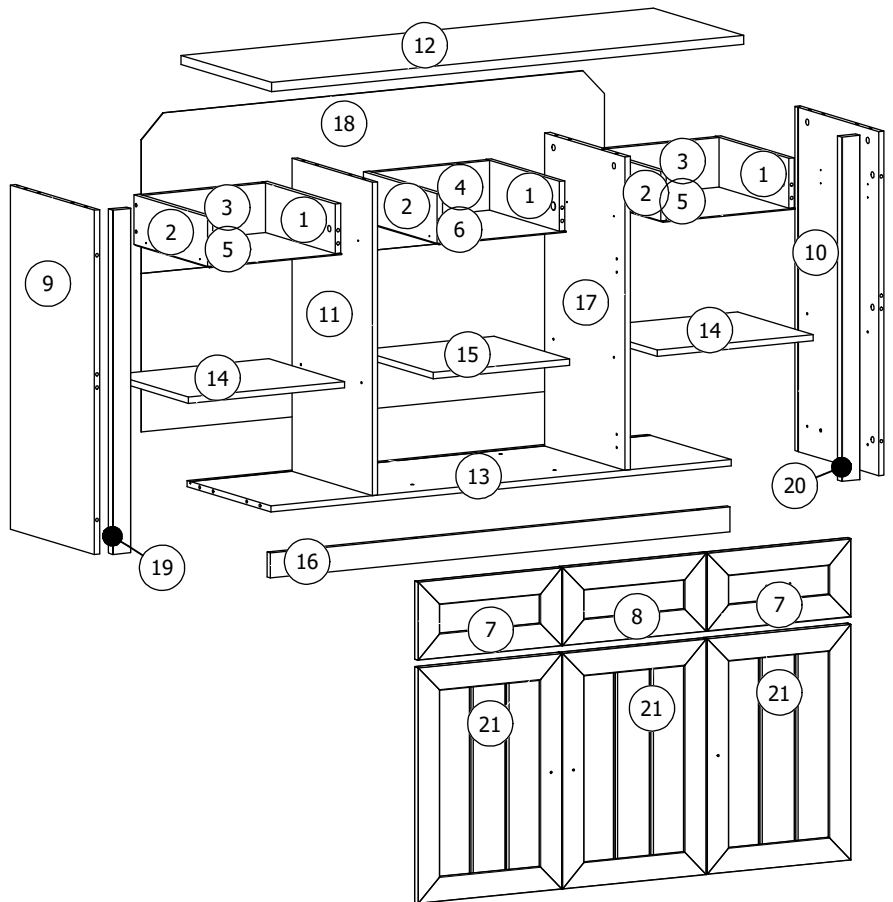

nr	L[mm]	B[mm]	T[mm]	Menge	Colli
1	120	350	15	3	3/3
2	120	350	15	3	3/3
3	120	336	15	2	3/3
4	120	322	15	1	3/3
5	363	355	2,5	2	1/3
6	349	355	2,5	1	1/3
7	395	189	18	2	2/3
8	395	189	18	1	2/3
9	832	400	15	1	1/3
10	832	400	15	1	1/3
11	757	382	15	1	1/3
12	1299	430	22	1	3/3
13	1266	400	15	1	3/3
14	429	360	15	2	1/3
15	375	360	15	1	1/3
16	1265	60	15	1	3/3
17	757	382	15	1	1/3
18	766	1274	2,5	1	3/3
19	832	50	22	1	1/3
20	832	50	22	1	1/3
21	395	570	18	3	2/3

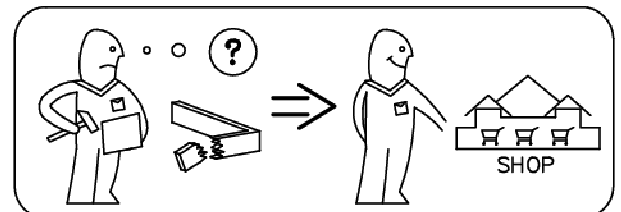



Achtung • Opgelet • Uwaga • Dikkat • Вниманіе •
Attention • Upozorneni • Figyelem • Allenzione • Atentie



D	Überschreiten Sie die angegebenen Maximalbelastungen nicht. Andernfalls kann das Möbelstück beschädigt oder zerstört werden.
GB	Do not exceed the maximum loads specified. Otherwise, the furniture may sustain damage or be irreparably damaged.
NL	Overschrijd de aangegeven maximale belastingen niet. Anders kan het meubelstuk worden beschadigd of vernield.
PL	Nie wolno przekraczać podanych maksymalnych wartości obciążenia. W innym przypadku można mebel uszkodzić lub zniszczyć.
TR	Belirtilen azami yuk degerini asmayiniz, aksi taktirde mobilya parcasi zarar gorebilir veya kullanilamazehale gelebilir.
RU	Не допускается превышение указанных максимальных нагрузок. В противном случае возможно повреждение или разрушение мебели.
FR	Ne dépassez pas les charges maximum indiquées. Sinon, le meuble peut être endommagé ou détruit.
CZ	Nepřekračujte uvedené maximální zatížení. V opačném případě může dojít k poškození nebo zničení nábytku.
HU	Tartsa be az engedélyezett maximális terhelhetőséget/tejesítményt. Különben a bútor és annak alkatrészei megsérülhetnek, tönkre mehetnek.
IT	Non superare il carico massimo indicato. Altrimenti il mobile rischia di rovinarsi o frantumarsi.
RO	Nu depasiti sarcile maxime specificate. Altfel puteti sa deteriorati sau sa distrugeti piesa de mobilier.
SK	Neprekročte uvedené maximálne zaťaženia. V opačnom prípade sa môže nábytok poškodiť alebo zničiť.

D	Die Befestigung des Möbelstückes an der Wand muss von einer fachkundigen Person vorgenommen werden, da für die Montage an die Wand angepasste Dübel erforderlich sind.
GB	A qualified professional is required when mounting furniture to the wall since dowels corresponding to the wall are required for this.
NL	Een vakkundige persoon dient het meubelstuk aan de muur te bevestigen; voor de montage aan de muur zijn immers aangepaste pluggen vereist.
PL	Mocowanie mebla do ściany mogą przeprowadzić wyłącznie wykwalifikowane osoby, z uwagi na zastosowanie odpowiednio dopasowanych kołków do rodzaju ściany.
TR	Mobilya parçasının duvara sabitlenmesi, duvar montajı için özel uyulanmış dübeller gerektirdiğinden bu iş sadece bu konuda uzman bir kişi tarafından gerçekleştirilmelidir.
RU	Поскольку для монтажа на стене необходимо использовать специальные дюбеля, мебель должна быть закреплена на стене квалифицированным персоналом.
FR	La fixation du meuble contre le mur doit être effectuée par une personne compétente car, pour le montage mural, il faut utiliser des chevilles adaptées.
CZ	Montáž nábytku na stěnu musí provést odborník, protože k montáži na stěnu jsou zapotřebí upravené hmoždinky.
HU	A bútorlemek falra rögzítését szakembernek kell végeznie, mert a rögzítéshez megfelelő tiplít kell használni.
IT	Il fissaggio del mobile alla parete deve essere eseguito esperte, dato che occorrono tasselli adeguati.
RO	Fixarea la perete a piesei de mobilier se realizeaza numai de catre personal competent, deoarece montajul de perete necesita dibluri adecvate.
SK	Upevnenie nábytku na stenu musí vykonať odborník, nakoľko sú pre montáž na stenu potrebné vhodné hmoždinky.