









# ASSEMBLY INSTRUCTIONS & PARTS IDENTIFICATION COUNTER STOOL

Thank you for purchasing this quality product. Be sure to check all packing material carefully for small parts that may have come loose inside the carton during shipment.

Hardware kit Description				
No		Description		Q'Ty
A		Hexa Nut	Ø8	4 pcs
B		Lock Washer	Ø8	10 pcs
C		Flat Washer	Ø8	10 pcs
D		Long Bolt	Ø7.8 x 80mm	4 pcs
E		Short Bolt	Ø7.8 x 35mm	2 pcs
F		Allen Key		1 pc
G		Key Wrench		1 pc
H		Screw	Ø4 x 40mm	6 pcs

Key Parts			
No	Code	Description	Q'Ty
1		Chair Back	1 pc
2		Complete Seat	1 pc
3		Right Facing Front Leg	1 pc
4		Left Facing Front Leg	1 pc
5		Right Facing Side Stretcher	1 pc
6		Left Facing Side Stretcher	1 pc
7		Front Facing Side Stretcher	1 pc
8		Floor glide	4 pcs

## STEP 1

- Carefully lay Chair Back flat on a smooth flat surface to prevent scratches.
- Attach Complete Seat to Chair Back by inserting a Flat Washer (C), Lock Washer (B) with Short Bolt (E) into each of the hole on the back rail of the seat. Attach the Long Bolt (D), Lock Washer (B) and Flat Washer (C) into each of 2 holes in the Complete Seat corners. (See Detail A & B).
- Tighten screws with provided Allen Key (F) by turning clockwise until secure.

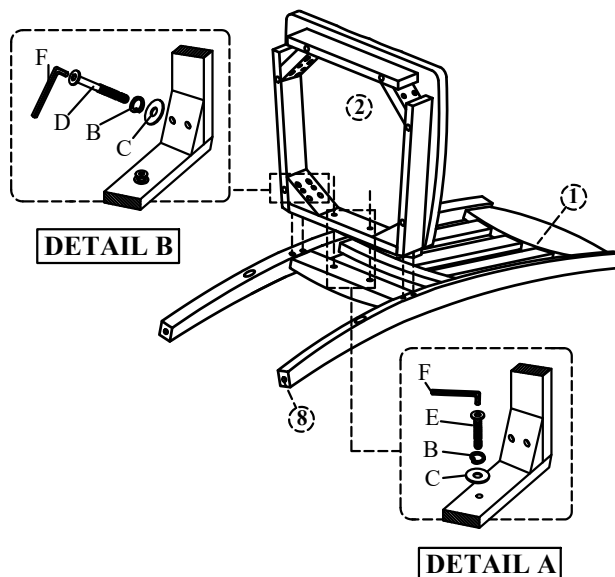

## DETAIL D

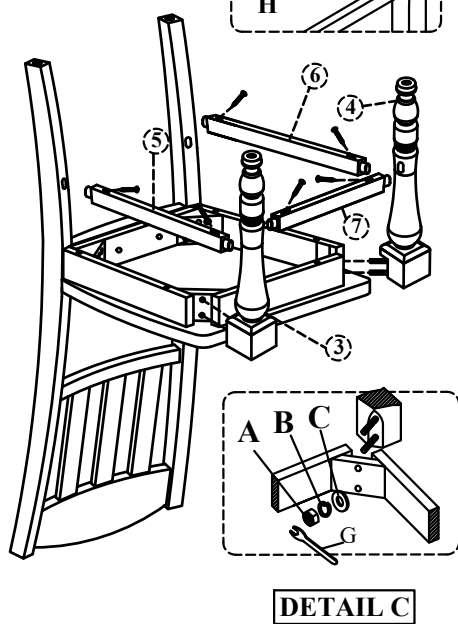
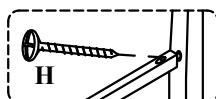

## DETAIL C

## STEP 2

- Carefully turn Chair upside down and attach each Leg to the front corners of the Complete Seat.
- Place Flat Washer (C), Lock Washer (B) and Nut (A) on for each bolt, using provided Key Wrench (G).
- Do not fully tighten the Nuts at this stage until all the parts are in position (See Detail C).
- Insert 2 Side Stretchers between the Front Legs, fasten with Wood Screw using phillip-head screwdriver. (not provided). (See Detail D)
- Be sure to tighten all screws and nuts prior to using Chair.

