

Metal Storage Shed 8'x8' FT

Instructions for Assembly

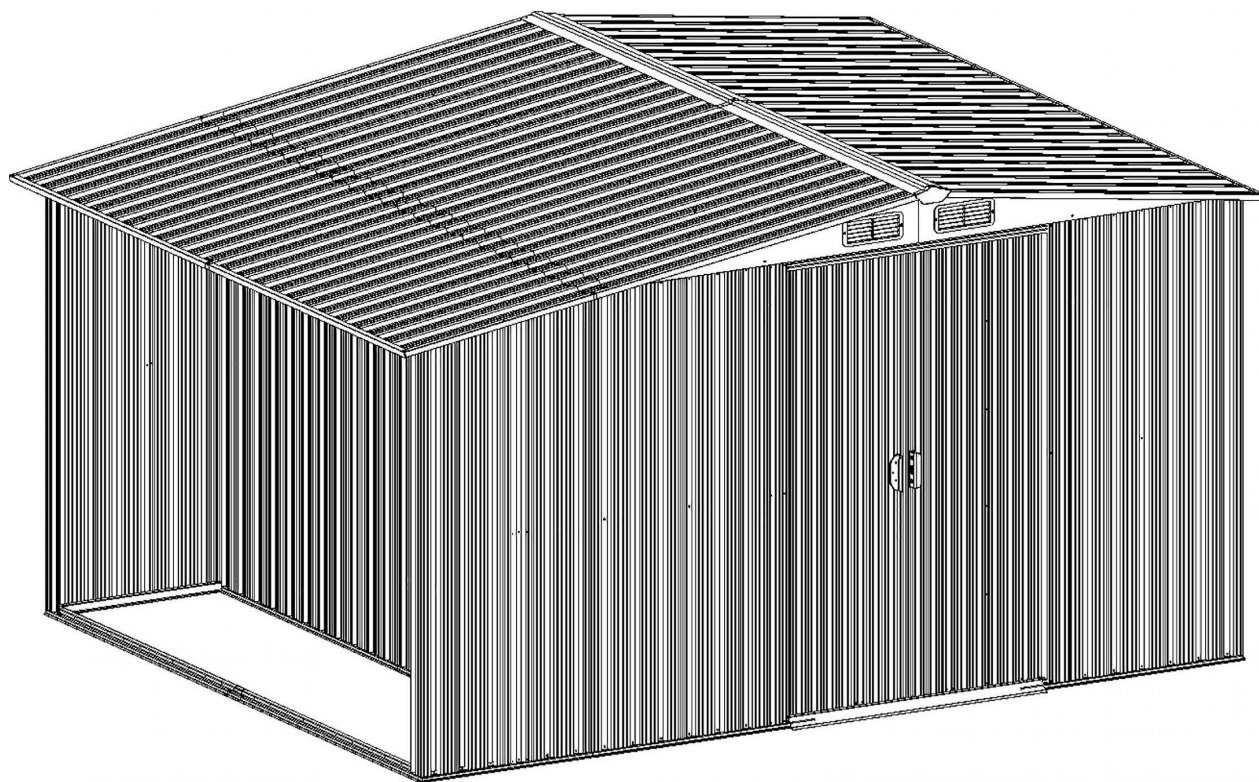

It will take 2-3 hours for 2 people to install.

WARNING

Please read the instruction manual carefully before assembly

Please assembly strictly in accordance with the instruction

Please double-check to ensure that all parts of the package contents intact

To avoid injury , work gloves are recommended during assembly

Owner's Manual

Before beginning construction, check local building codes regarding footings, location and other requirements. Study and understand this owner's manual. Important information and helpful tips will make your construction easier and more enjoyable.

Assembly Instructions: Instructions are supplied in this manual and contain all appropriate information for your building model. Review all instructions before you begin, and during assembly, follow the step sequence carefully for correct results.

Parts and Parts List: Check to be sure that you have all the necessary parts for building .

Separate contents of the carton by the part number while reviewing parts list.

The first few steps show how to join related parts to make larger sub assemblies which will be used later.

Familiarize yourself with the hardware and fasteners for easier use during construction.

These are packaged within the carton. Note that extra fasteners have been supplied for your convenience.

PLAN AHEAD

Watch the Weather: Be sure the day you select to install your building is dry and calm.

Do not attempt to assemble your building on a windy day.

Teamwork: Whenever possible, two or more people should work together to assemble your building. One person can position parts or panels while the other is able to handle the fasteners and the tools.

Tools and Materials: These are some basic tools and materials you will need for the construction of your building. Decide which method of anchoring and the type of foundation you wish to use in order to form a complete list of the materials you will need.

CARE & MAINTENANCE

Finish: For long lasting finish, periodically clean and wax the exterior surface. Touch-up scratches as soon as you notice them on your unit. Immediately clean the area with a wire brush; wash it and apply touch-up paint per manufacturer's recommendation.

Roof: Keep roof clear of leaves and snow with long handled, soft-bristled broom. Heavy amounts of snow on roof can damage building making it unsafe to enter. In snow country, Roof Strengthening Kits are available for most Arrow Buildings for added protection against heavy snow accumulation.

Doors: Always keep the door tracks clear of dirt and other debris that prevent them from sliding easily. Lubricate door track annually with furniture polish or silicone spray. Keep doors closed and locked to prevent wind damage

Fasteners: Use all washers supplied to protect against weather infiltration and to protect the metal from being scratched by screws. Regularly check your building for loose screws, bolts, nuts, etc. and retighten them as necessary.

Moisture: A plastic sheet (vapor barrier) placed under the entire floor area with good ventilation will reduce condensation.



















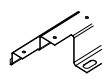

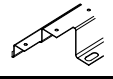
Other Tips....



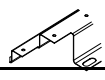
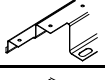















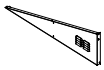
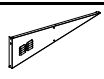



Wash off inked part numbers on coated panels with soap and water.



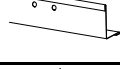













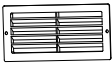
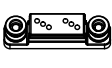

Silicone caulking may be used for watertight seals throughout the building.

Do not store swimming pool chemicals in your building. Combustibles and corrosives must be stored in air tight approved containers.

Wood Storage 8' x8'

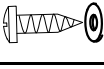

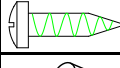





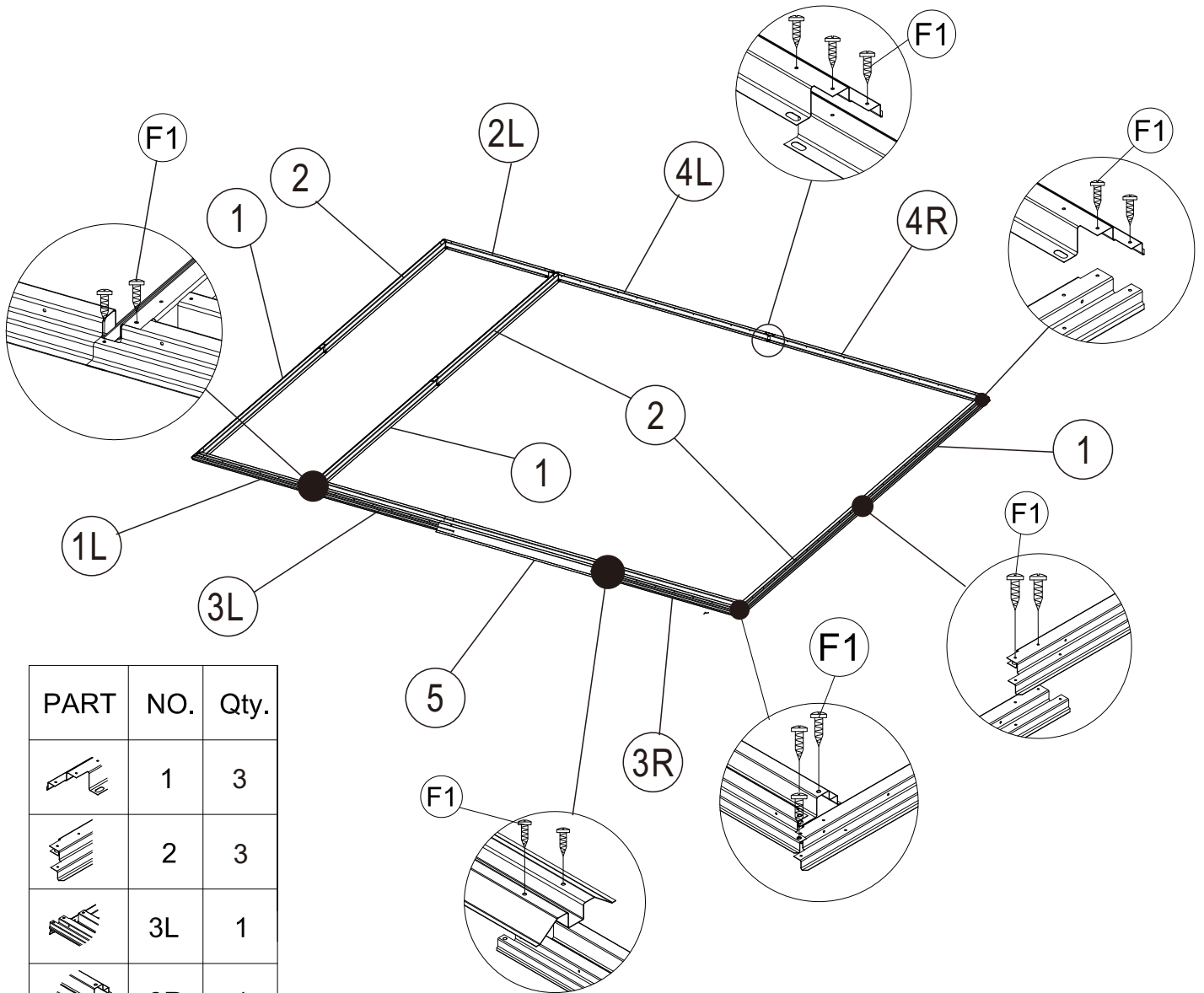

NO	PART	QTY
P3		14
6		1
19		2
28L		1
28R		1
7		1
8		1
13		4
1		3
2		3
1L		1
2L		1
3L		1
3R		1
4L		1
4R		1
5		1
9		2
9R		1
9L		1
11		2
10L		1

NO	PART	QTY
P1		2
P2		2
P1R		1
P1L		1
P2A		2
P2R		1
P2L		1
P4B		2
21L		2
21R		2
14		4
P5		6
P6		6
10R		1
15		4
17		2
18		2
20		4
22		2
23		2
24L		1
24R		1
B1		8

NO	PART	QTY
P5A		2
P6A		2
P5A-1		1
P6A-1		1
17A		1
18A		1
25L		1
25R		1
27		2
D1		1
D2		1
GF		4
G2		4
GB		2
GC		4
GD		4
GE		2
F1		522
F2		80
F3		8
S1		170
S2		600





1. Put foundation 1-5 as order shown in the pic with bolts F1.

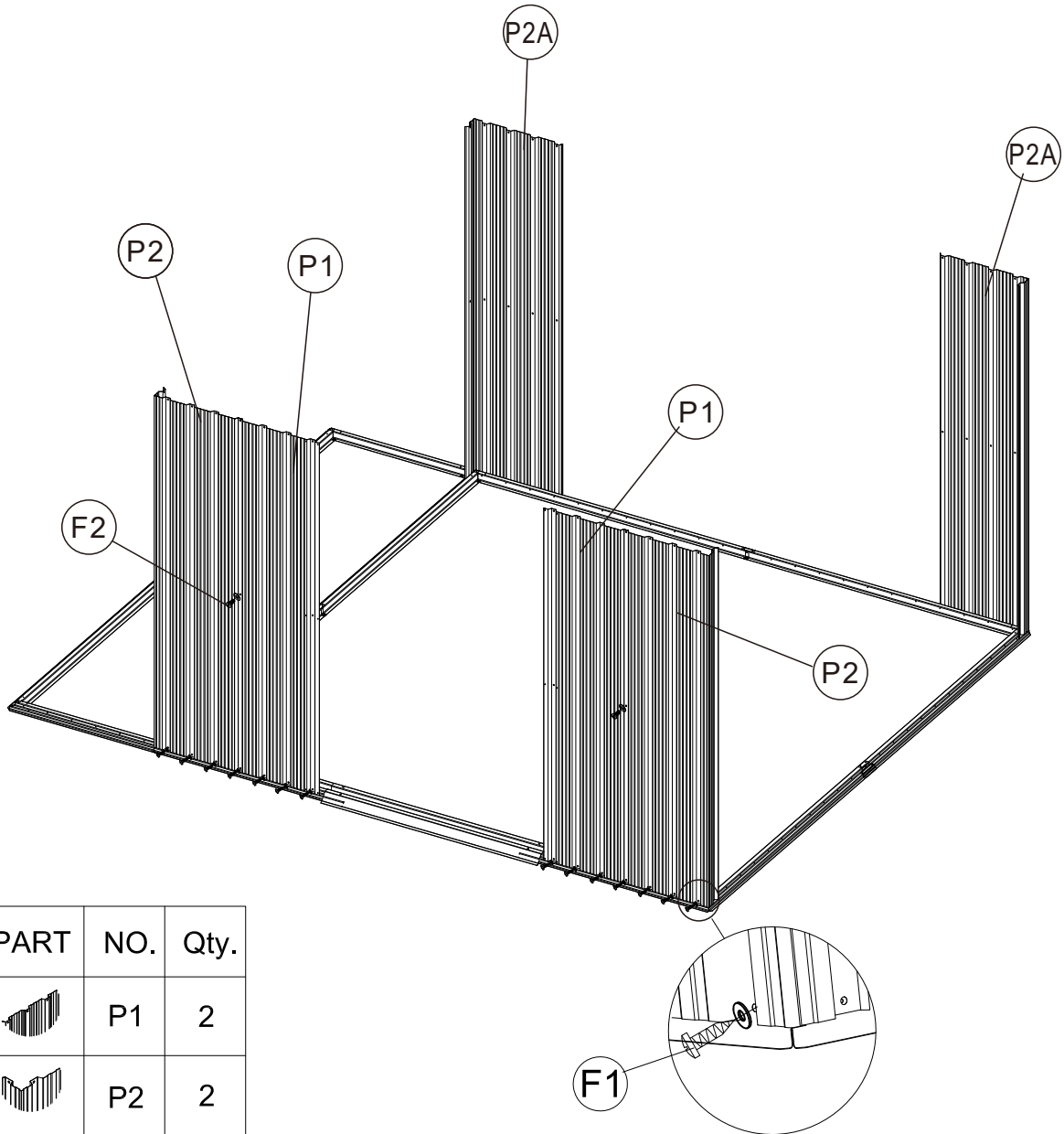

PART	NO.	Qty.			
	1	3			
	2	3			
	3L	1			
	3R	1			
	4L	1		1L	1
	4R	1		2L	1
	5	1		F1	32

2. Install the wall panels P1,P2,P2A onto the foundation as shown in the pic,and fix them with bolts F1.
 Fix wall panels with F2.







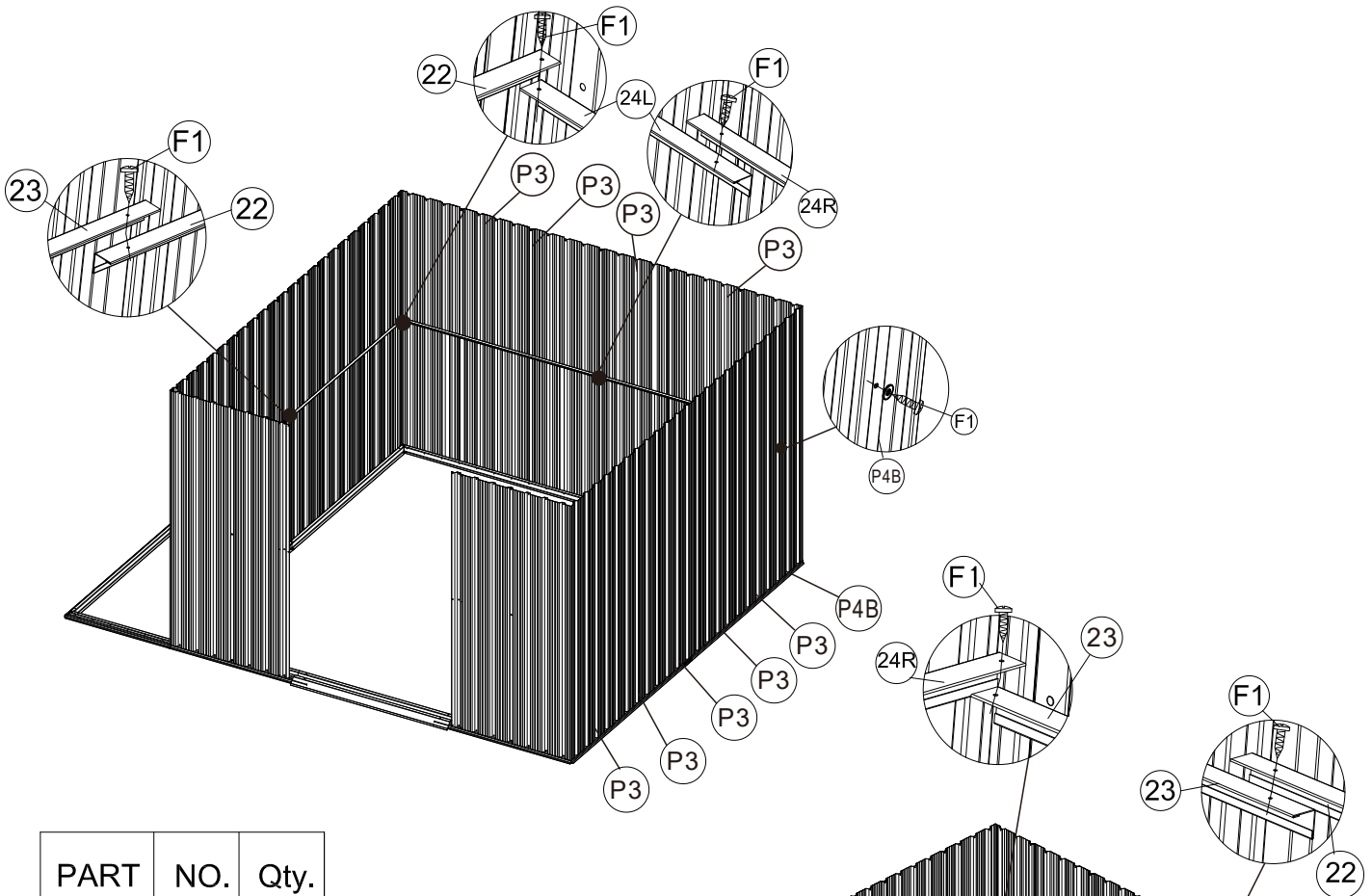

PART	NO.	Qty.
	P1	2
	P2	2
	P2A	2
	F1	22
	F2	2

3.

Fix 22,23,24L,24R onto wall panels as order shown in the pic with bolts F1. Fix wall panels P3,P4B onto foundation as shown in the pic and connect them with 22,23,24L,24R--with bolts F1.





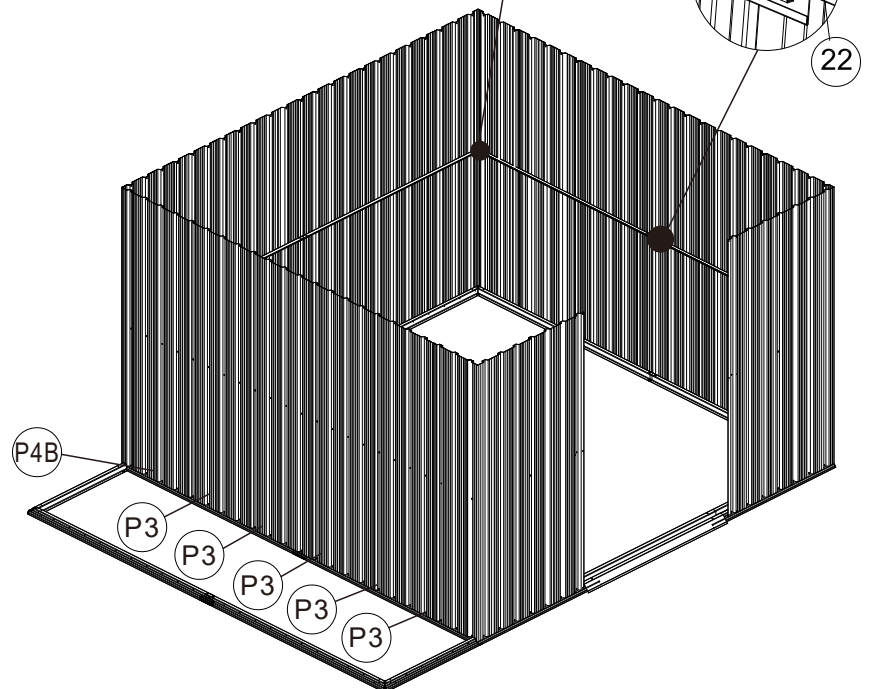

PART	NO.	Qty.
	22	2
	23	2
	24L	1
	24R	1
	P3	14
	P4B	2
	F1	133

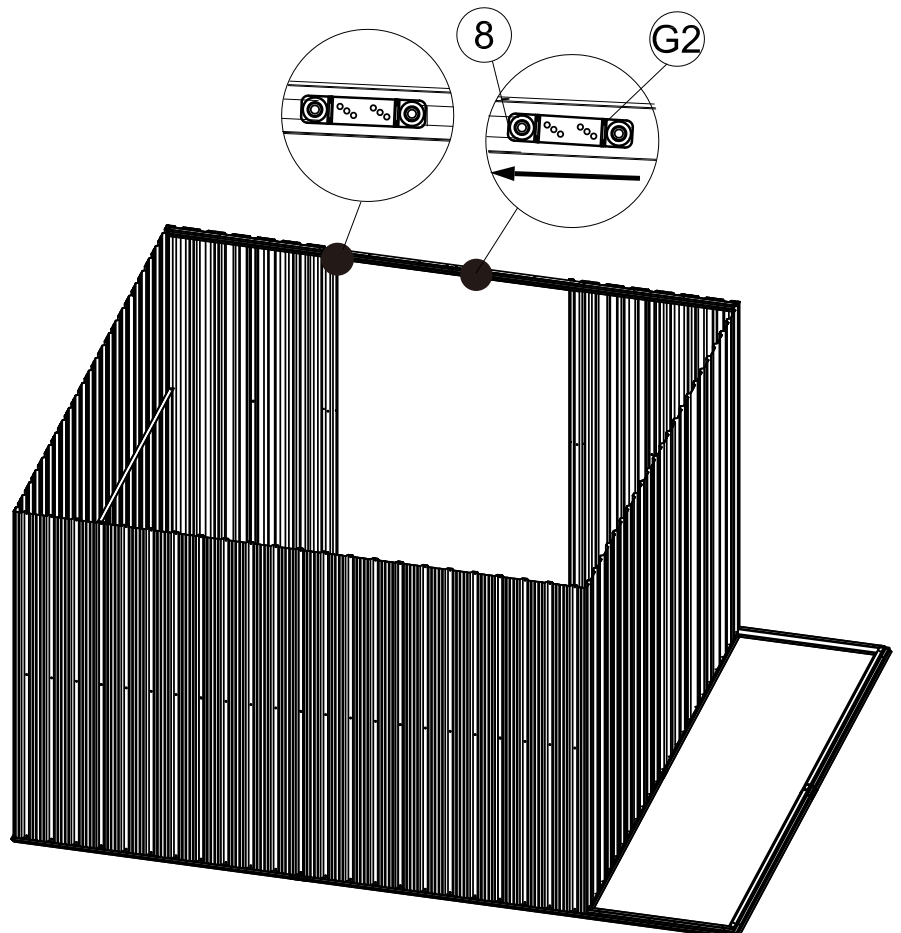
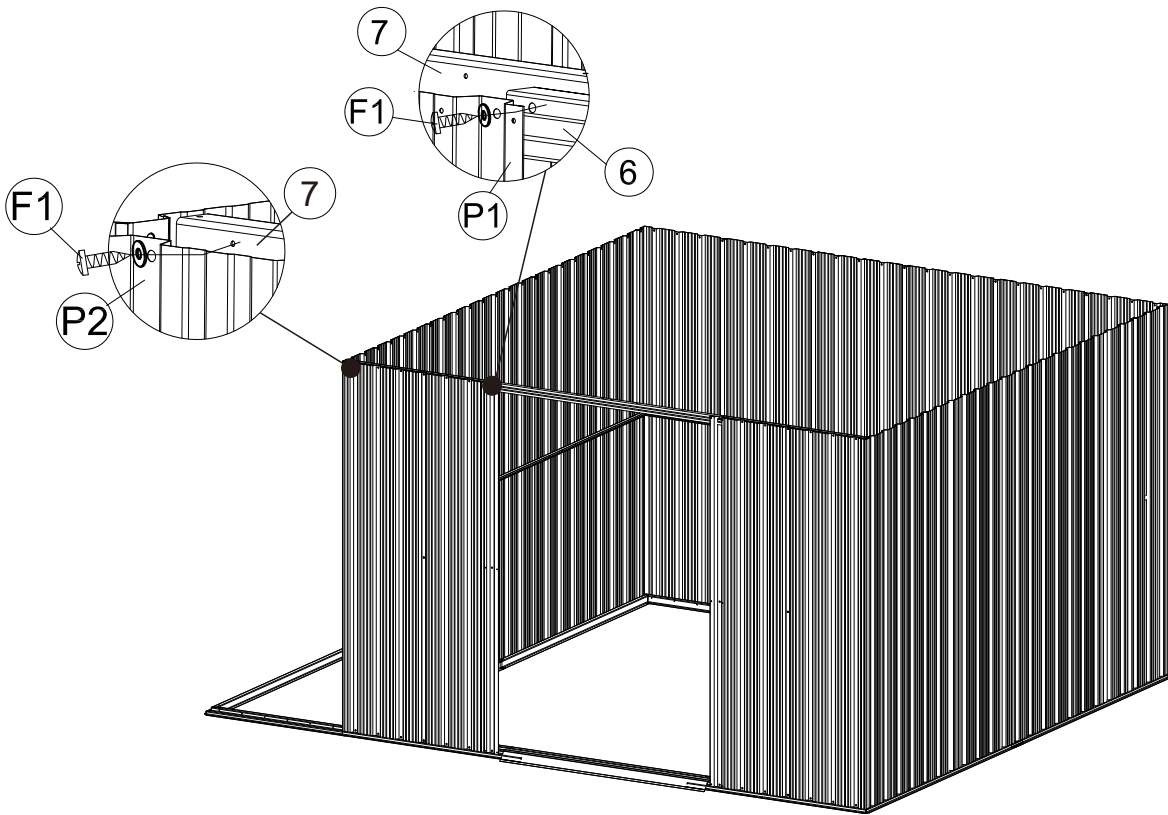





4. Slide 2pcs of G2 into channel 7 and 8 separately, fix 7 and 8 onto front wall panels with bolts F1.
 Fix 6 onto 7, 8 and front wall panels with bolts F1.
 PS: There is no holes on 7 and 8 since that they are very soft. It is very easy to fix them.

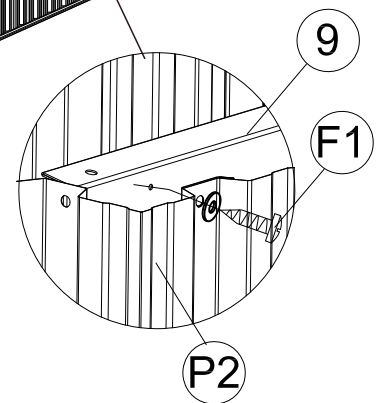
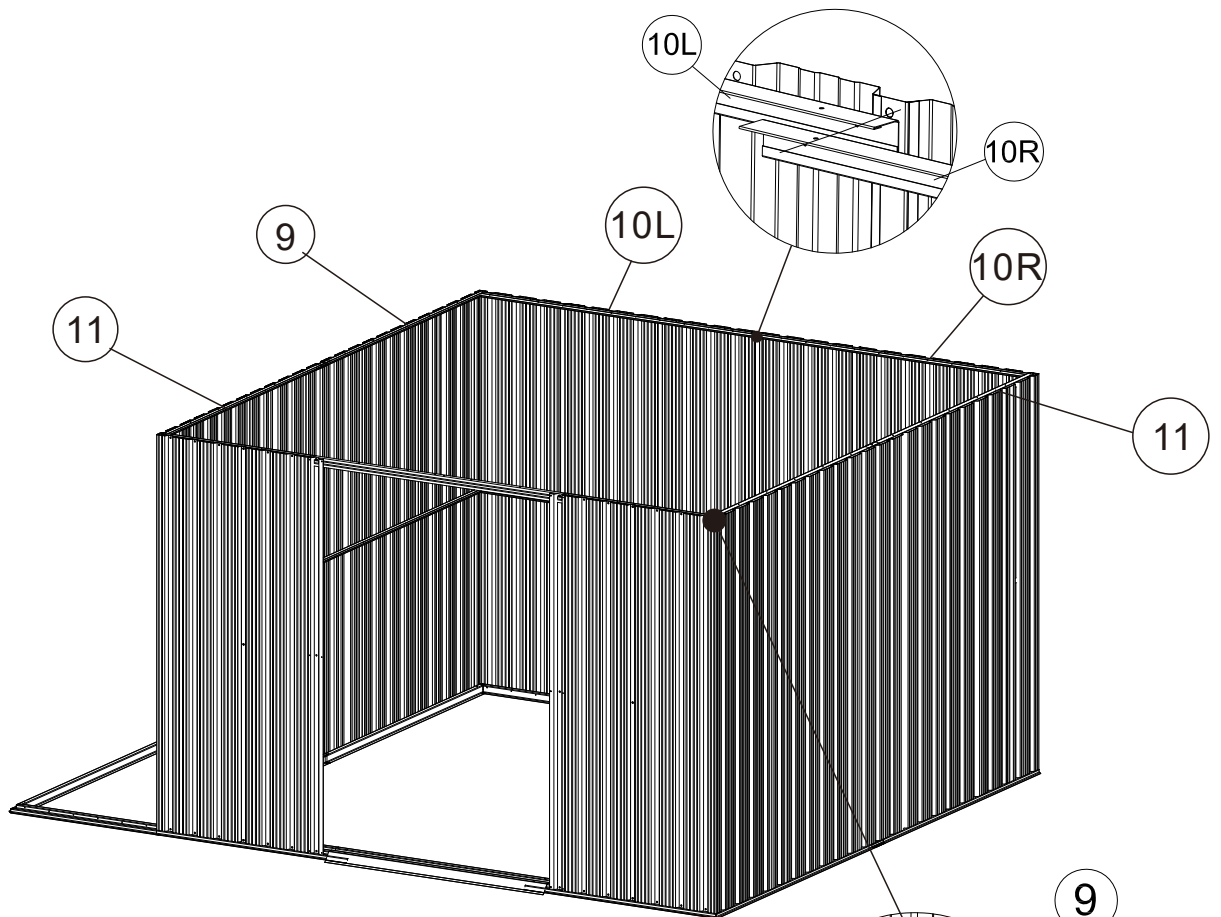

PART	NO.	Qty.
	6	1
	7	1
	8	1
	G2	4
	F1	12

5. Fix 9,11,10L,10R onto wall panels as shown in the pic with bolts F1.



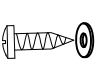

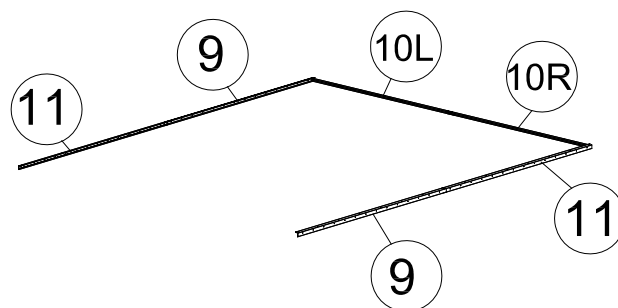
PART	NO.	Qty.
	9	2
	10L	1
	10R	1
	11	2
	F1	71



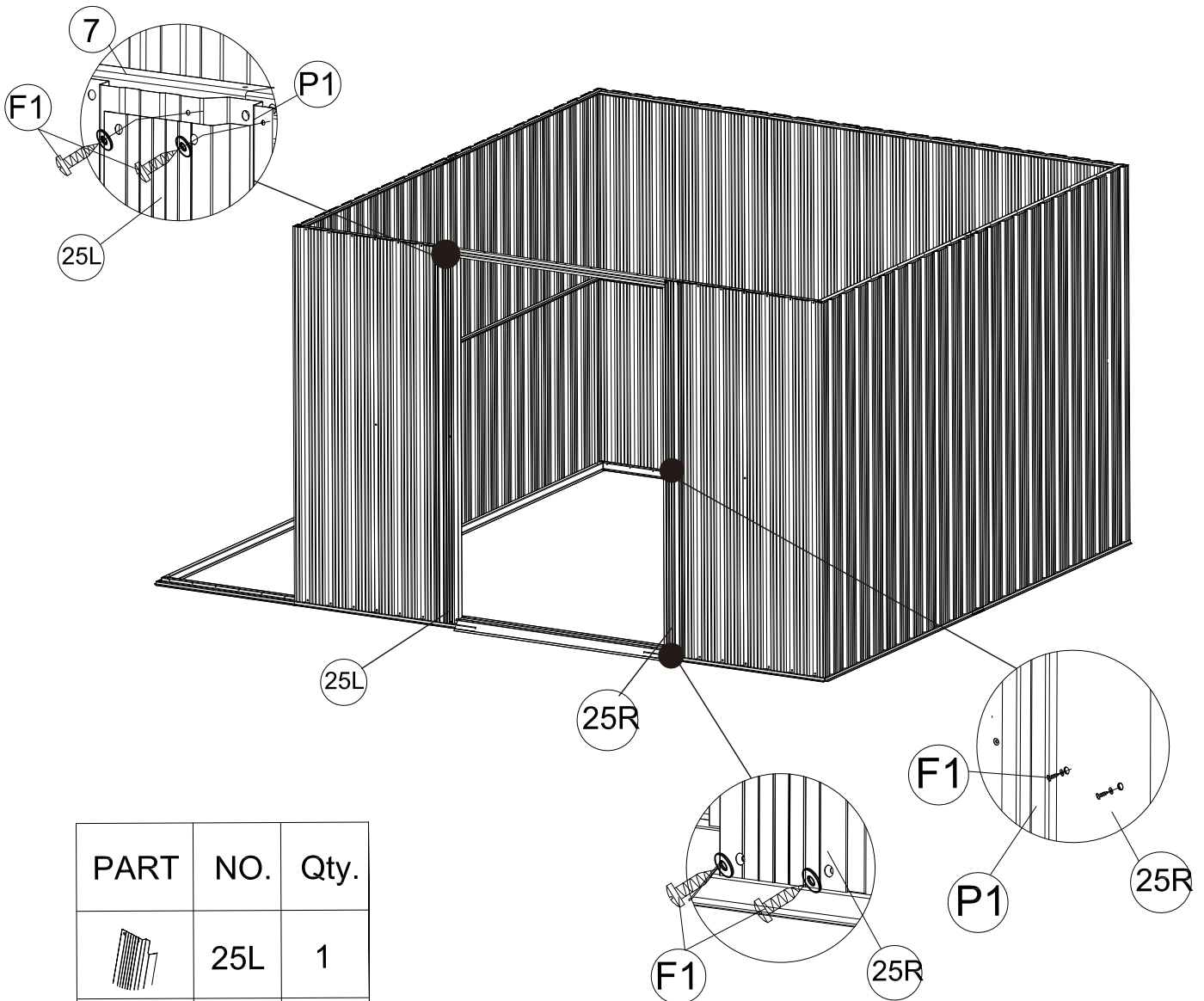





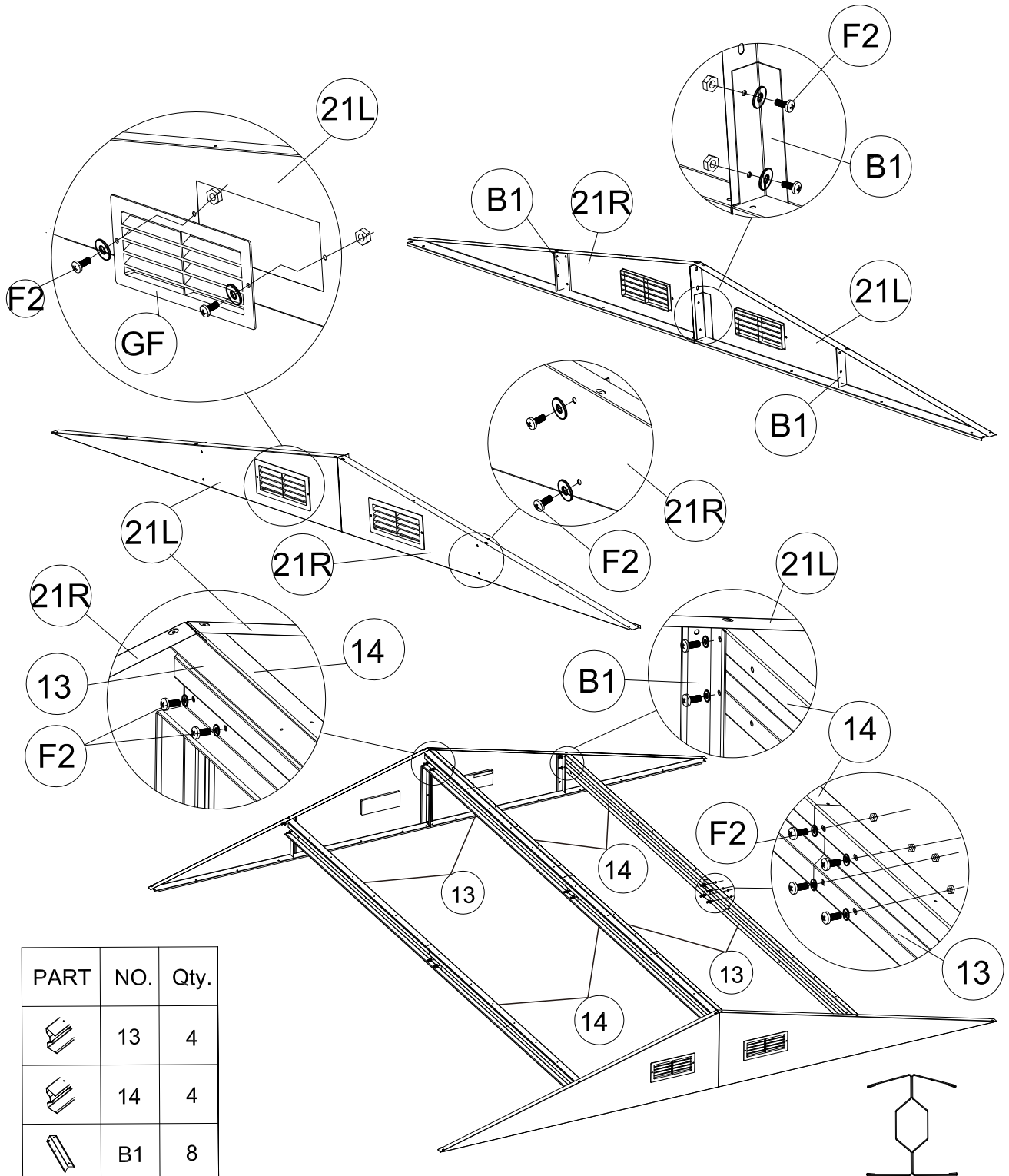

6. Put door frames 25L and 25R as order shown in the pic, and fix them onto wall panels with bolts F1.



PART	NO.	Qty.
	25L	1
	25R	1
	F1	12

7. Fix 1pc of 21L,21R and 4pcs of B1 as shown in the pic with bolts F2.
 Same for other 21L,21R and B1.
 Fix four windows GF onto the window holes with bolts F2.
 Fix beam 13 and 14 as shown in the pic with bolts F2.
 Install fixed beam onto the set squares with bolts F2.



PART	NO.	Qty.			
	13	4			
	14	4			
	B1	8			
	21L	2		GF	4
	21R	2		F2	40

8. Install the fixed beam in the last step onto the shed top with bolts F1.

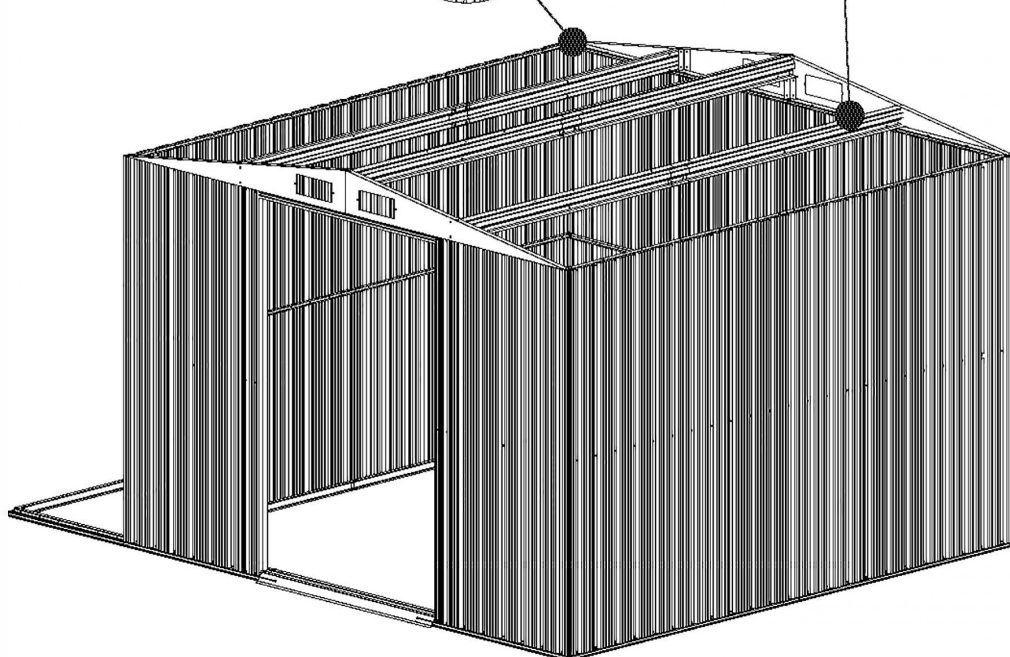
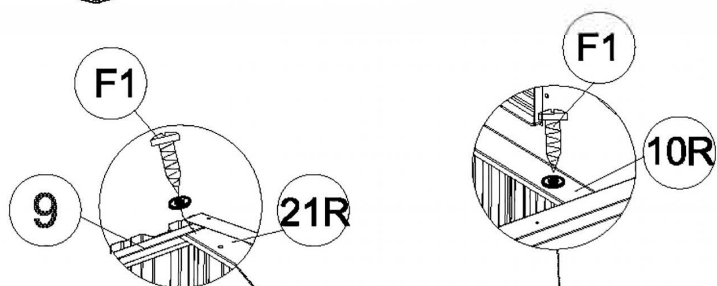
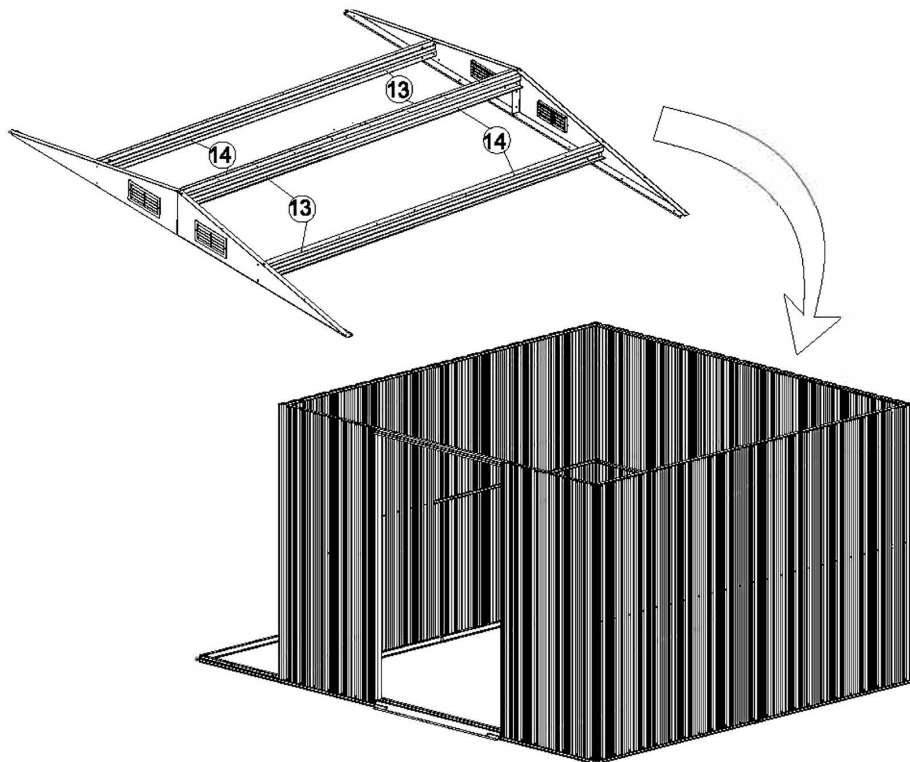

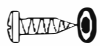

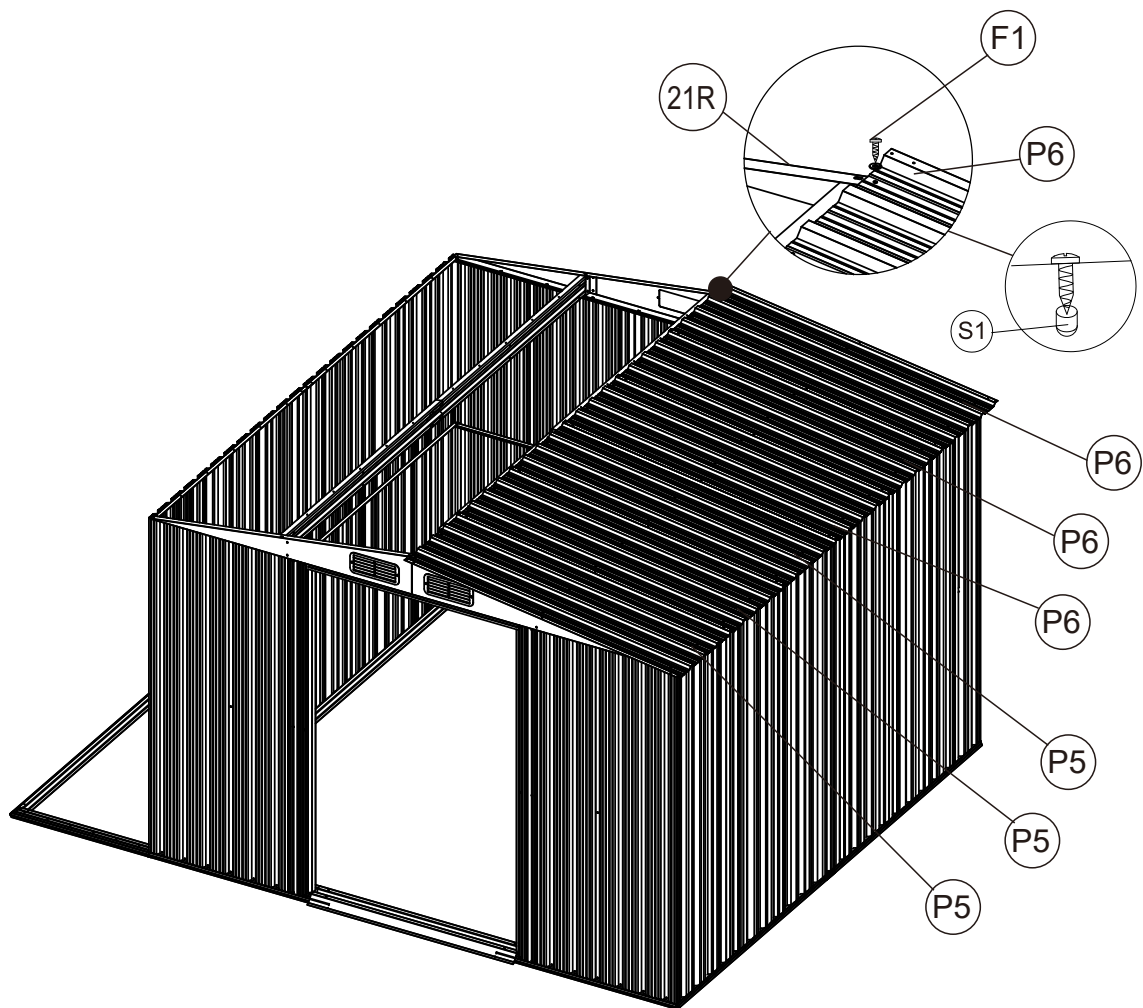

PART	NO.	Qty.
	F1	28

9.

Fix roof panels P5,P6 as shown in the pic with bolts F1.
Screw S1 ont bolts F1 to avoid scratch.









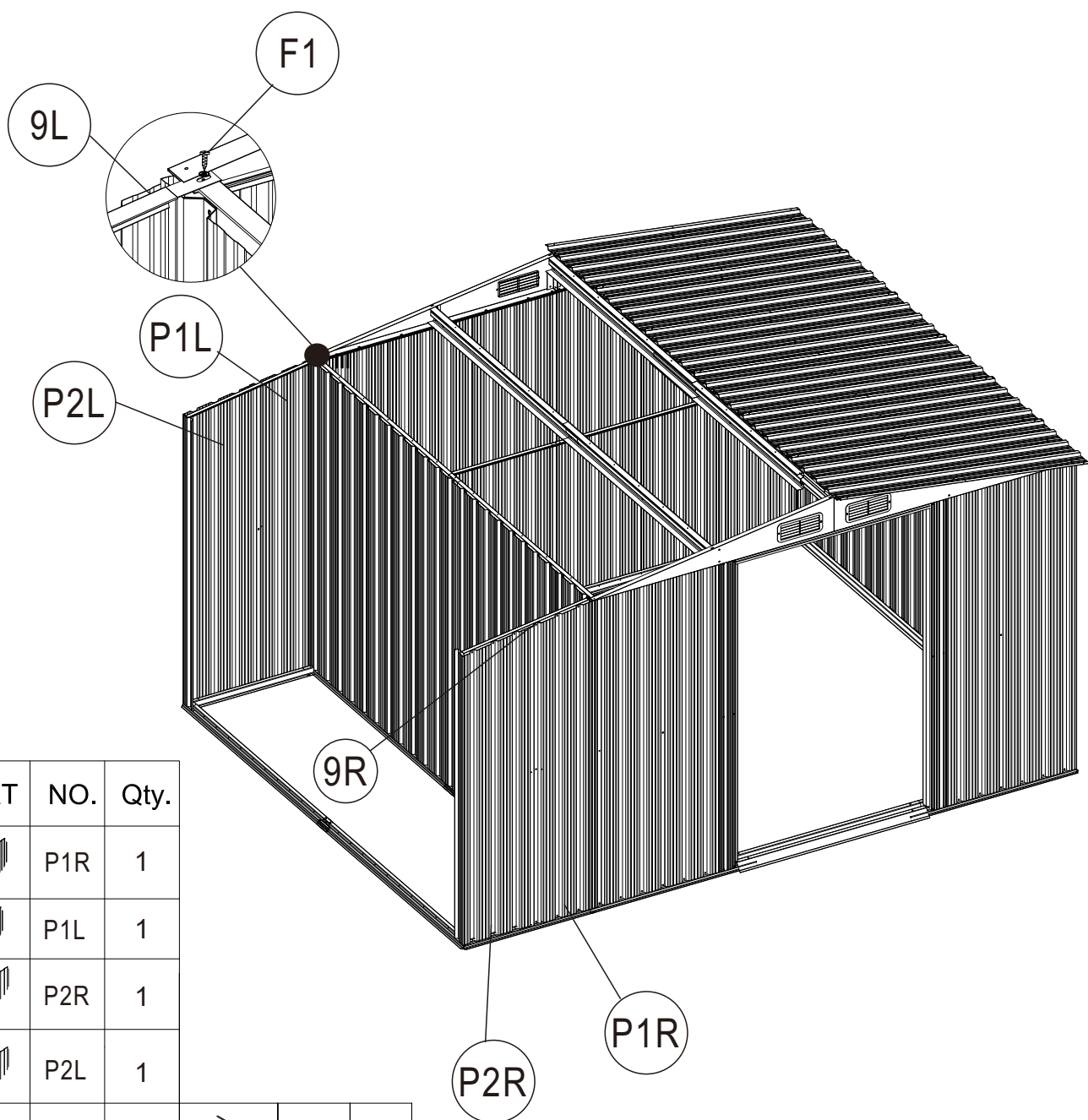

PART	NO.	Qty.
	P5	3
	P6	3
	F1	61
	S1	170

10.

Fix P1L,P1R,P2L,P2R onto foundation as shown in the pic with bolts F1, and fix panels with bolts F2.
Then fix 9L and 9R onto wall panels as shown in the pic with bolts F1.





PART	NO.	Qty.			
	P1R	1			
	P1L	1			
	P2R	1			
	P2L	1			
	F1	32		9R	1
	F2	4		9L	1

11.

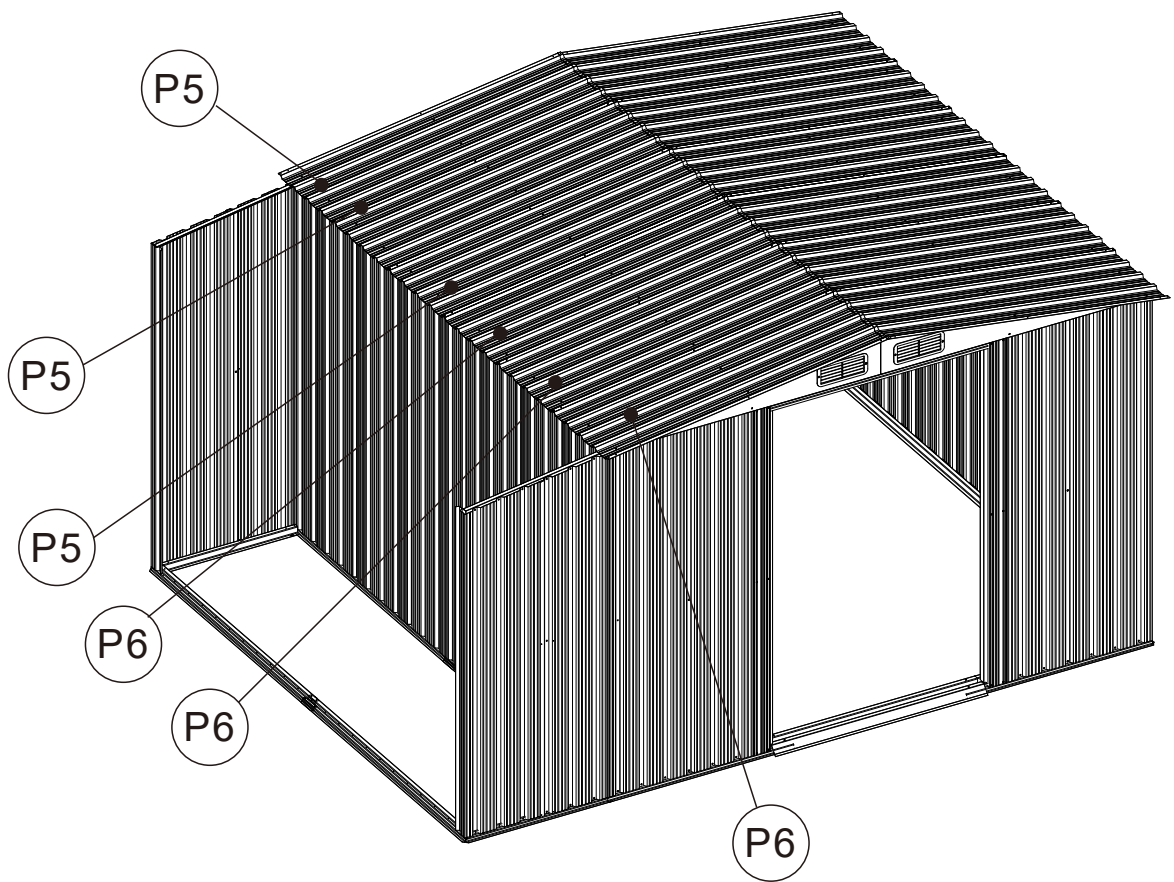



Fix roof panels P5,P6 as shown in the pic with bolts F1.

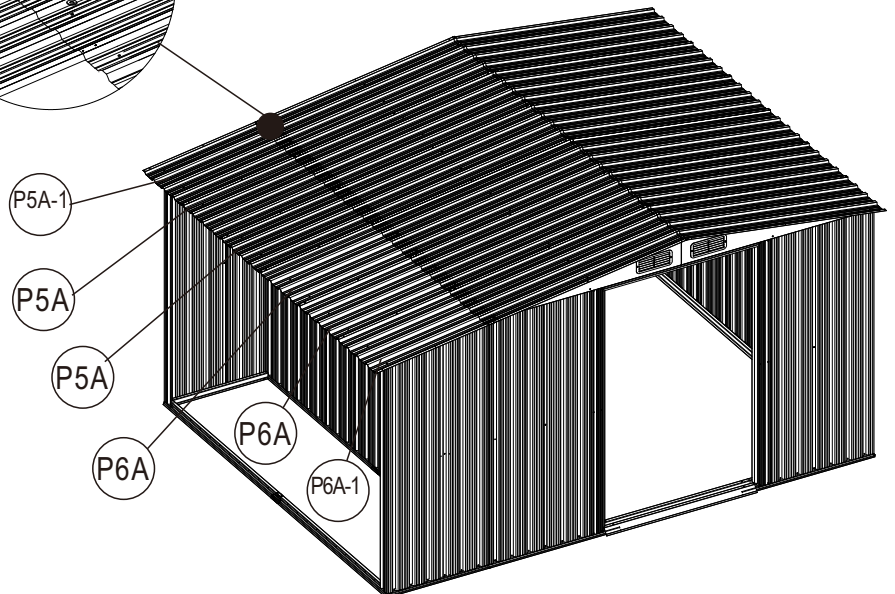
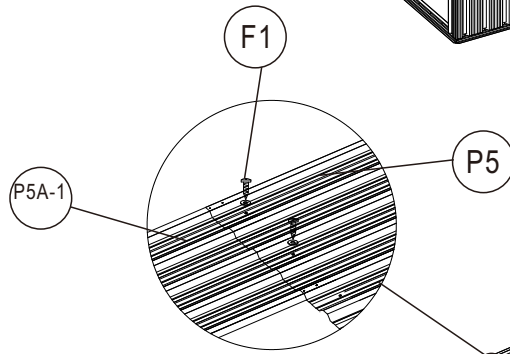
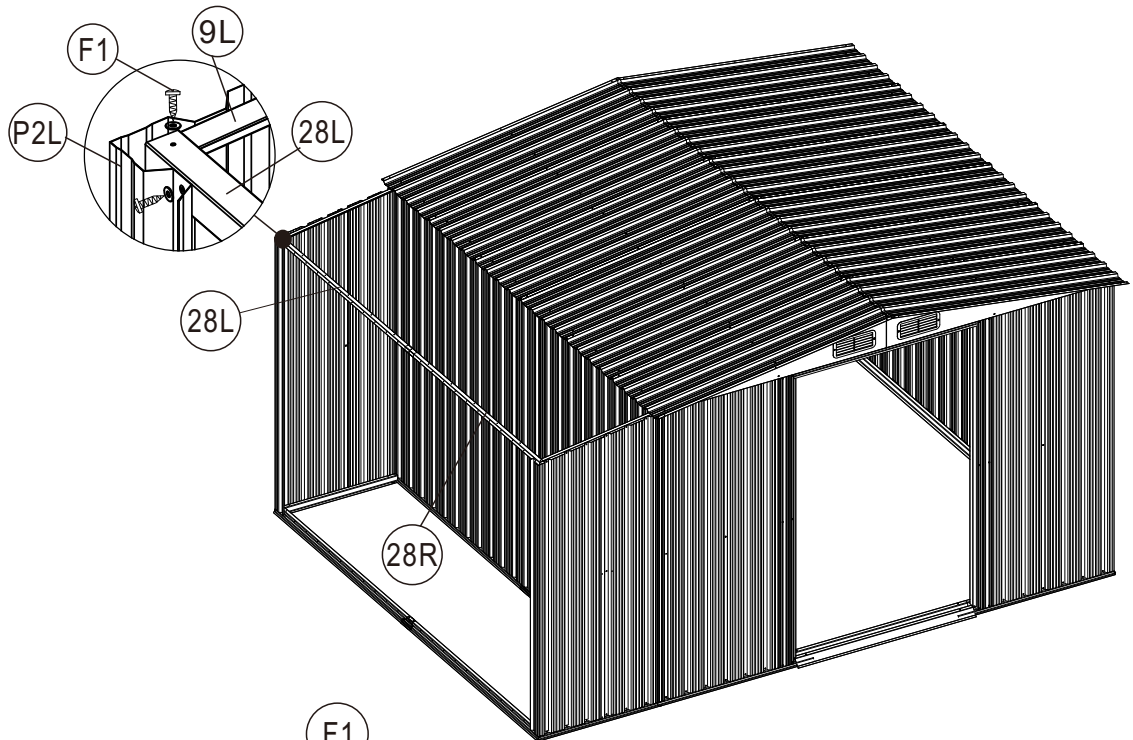

PART	NO.	Qty.
	P5	3
	P6	3
	F1	40







12. Fix 28L,28R as shown in the pic with bolts F1.
 Fix roof panels P5A,P6A as shown in the pic with bolts F1.

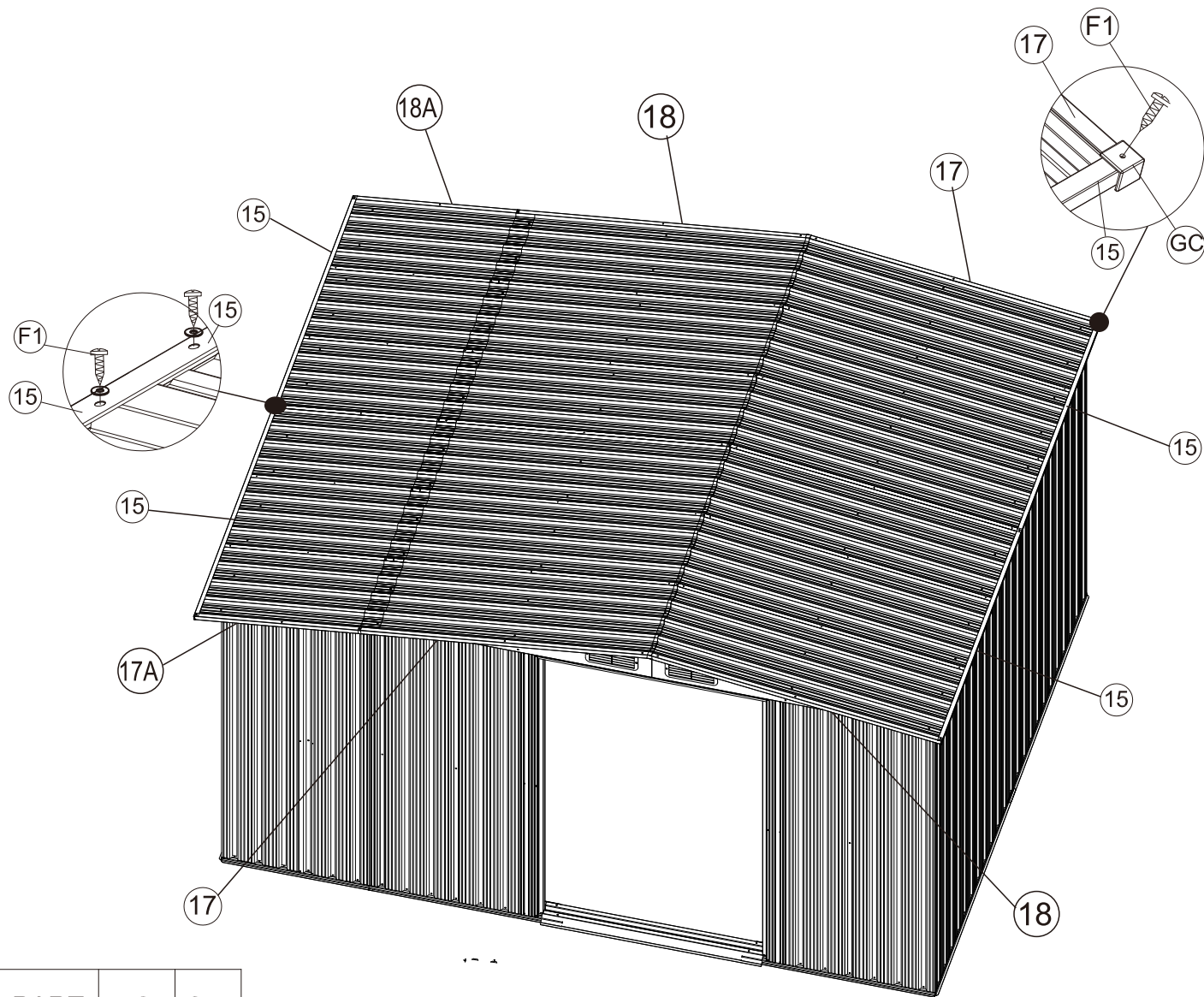

PART	NO.	Qty.
	P5A P5A-1	2 1
	P6A P6A-1	2 1
	28R	1
	28L	1
	F1	50

13. Fix protective edge 15,17,18,17A,18A and protective corner GC as shown in the pic with bolts F1.



PART	NO.	Qty.			
	15	4			
	17	2			
	18	2			
	GC	4		17A	1
	F1	20		18A	1

14.

Fix 2pcs of 19 with bolts F1 and F2 and put this onto roof.
Fix two ends of roof and 19 with bolts F1.
Fix GE onto two ends of 19 with bolts F1.

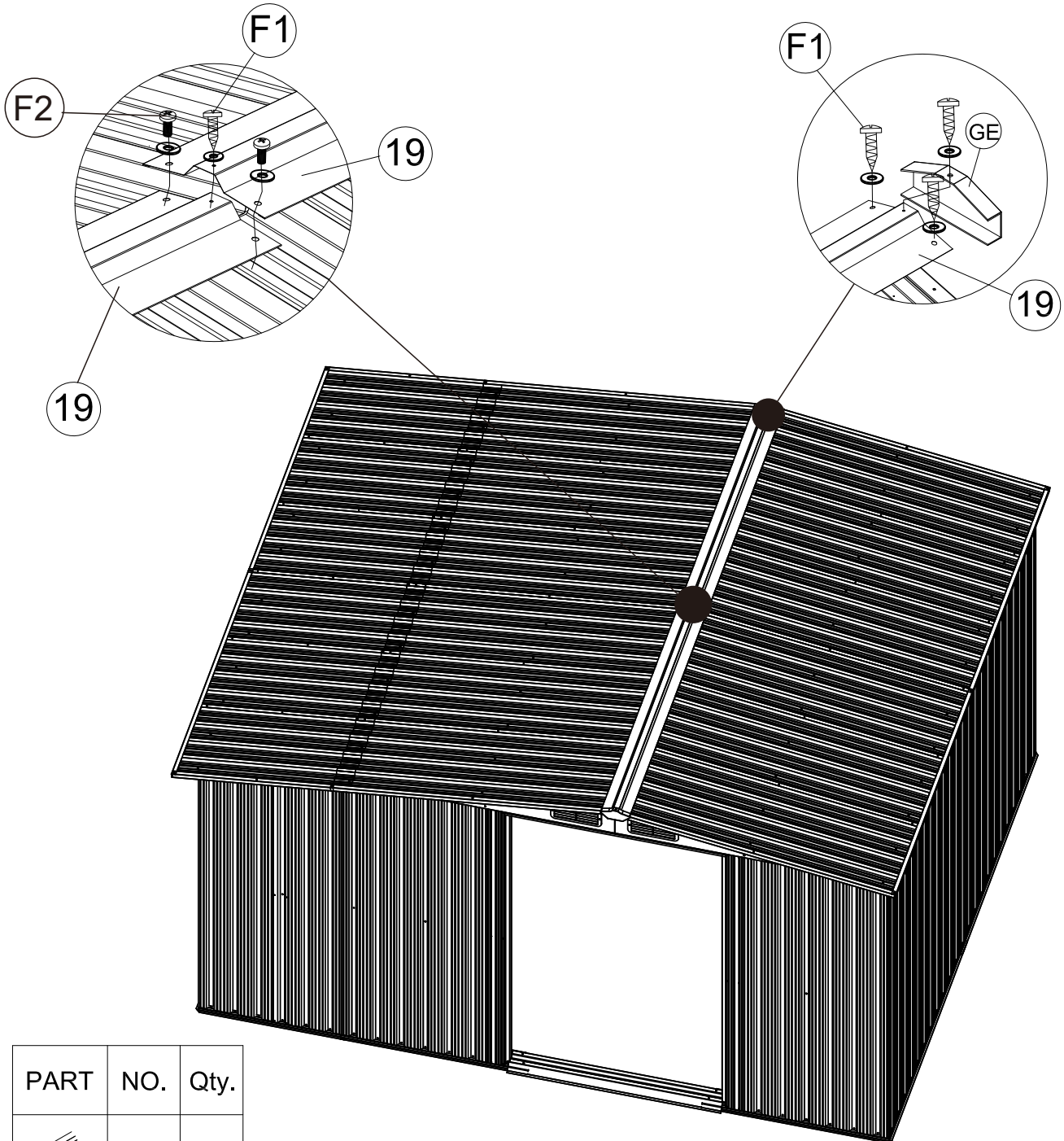





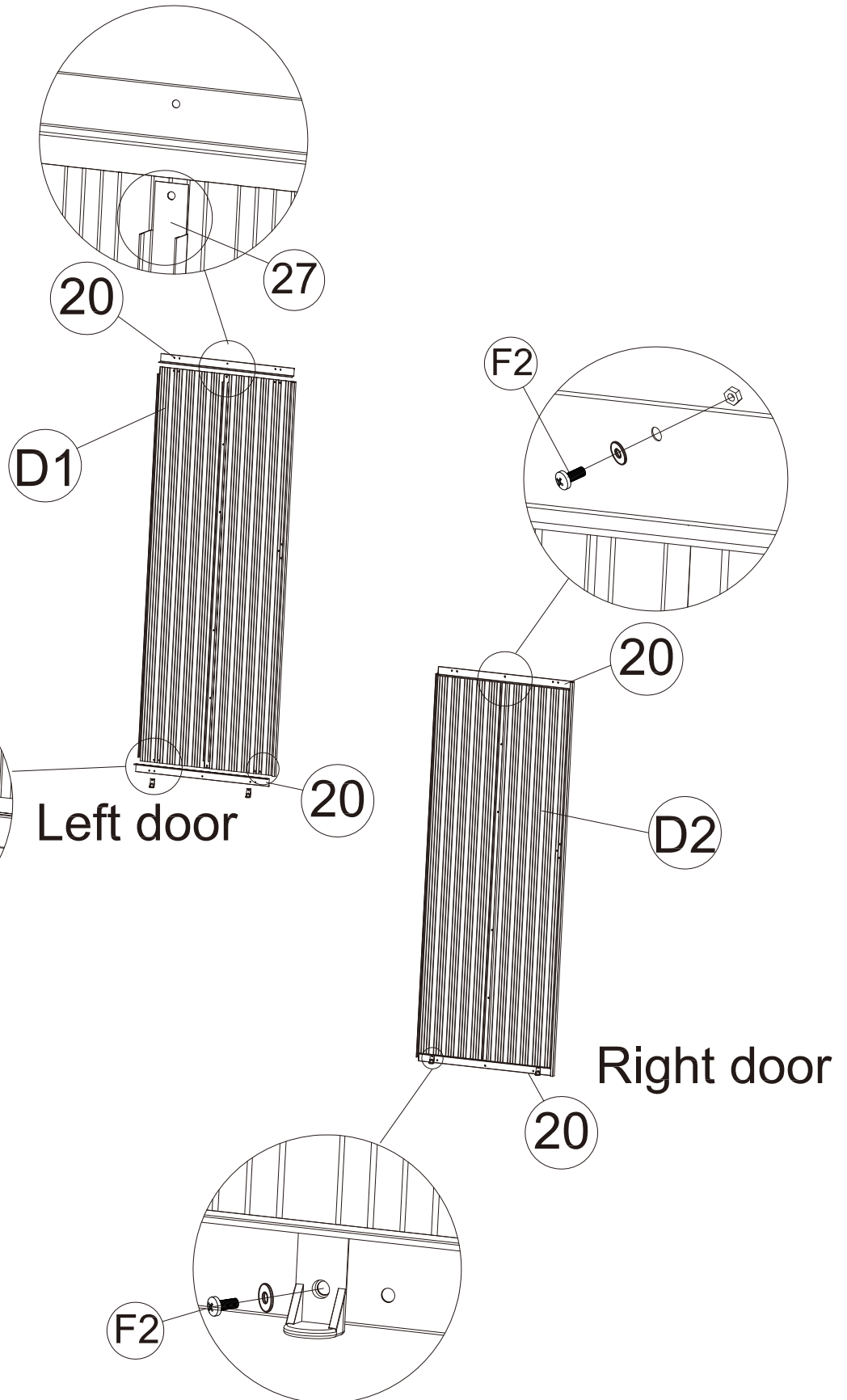

PART	NO.	Qty.
	19	2
	GE	2
	F1	9
	F2	2

15.

Fix 2pcs of 20, 1pc of 27, 2pcs of GD onto door panel D1 as shown in the pic with bolts F2.

Same way to other door D2.

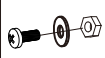

PART	NO.	Qty.
	27	2
	20	4
	D1	1
	D2	1
	GD	4
	F2	16

16.

Fix door bar GB onto door panels D1,D2 with bolts F2.

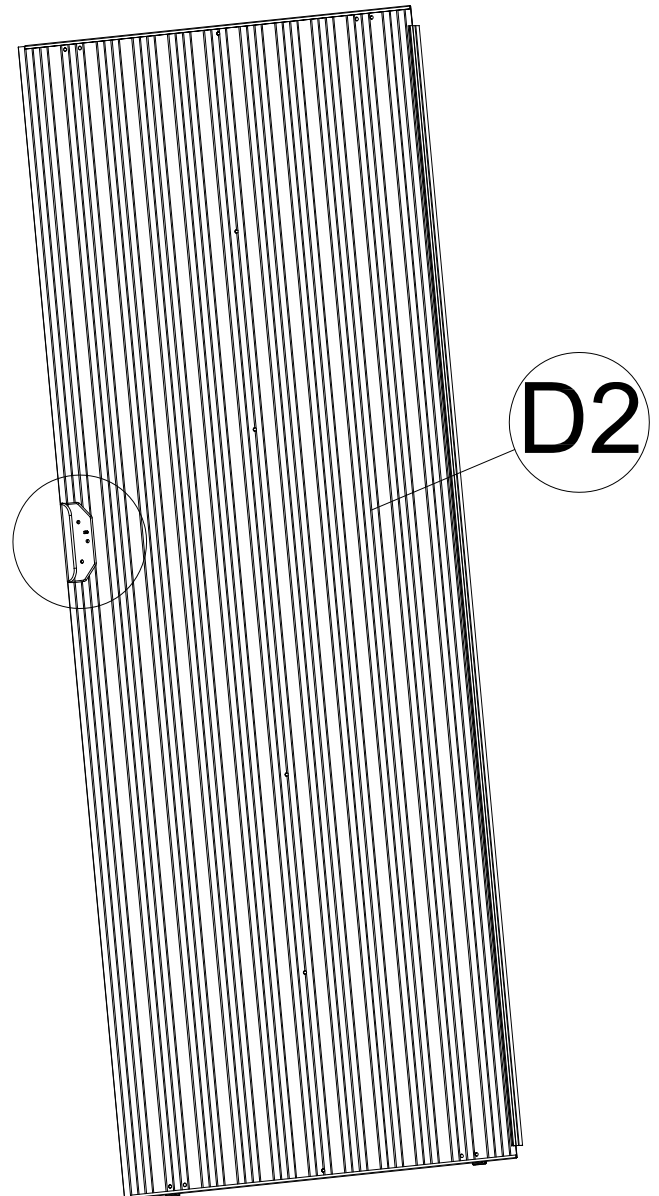
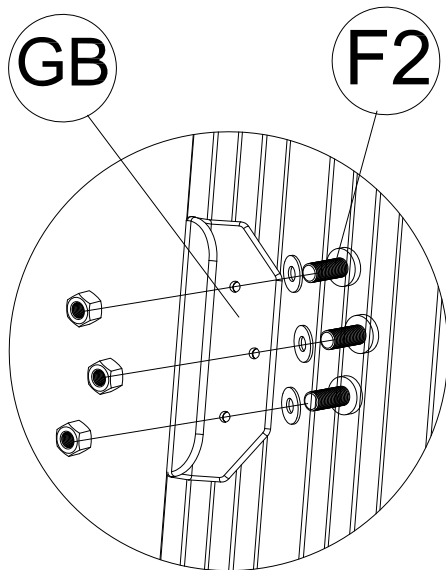

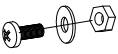
PART	NO.	Qty.
	GB	2
	F2	3

17.

Fix door panels D1,D2 as shown in the pic with bolts F3.

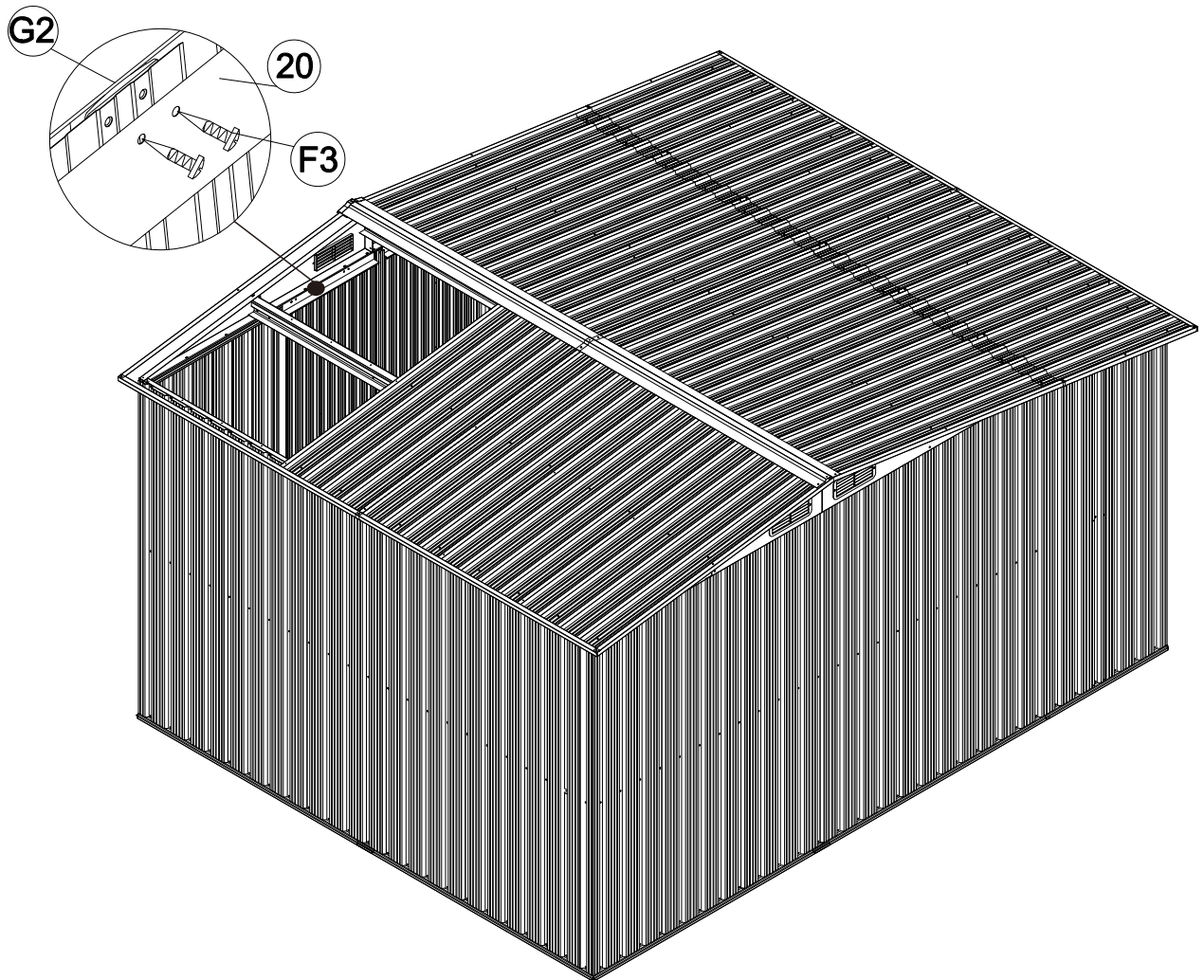

PART	NO.	Qty.
	F3	8