

Rustler2 - 4Burner/6Burner/Drop In Model#BG2211C4 /BMRUSDI4 Model#BG2211C6 /BMRUSDI6

WARNING
FOR YOUR SAFETY:
For Outdoor Use Only
(Outside any enclosure)

WARNING
FOR YOUR SAFETY:

- Improper Installation, adjustment, alteration, service or maintenance can cause injury or property damage.
- Read the installation, operation, and maintenance instructions thoroughly before installing or servicing this equipment.
- Failure to follow these instruction could result in fire or explosion, which could cause property damage, personal injury, or death.
- This instruction manual contains important information necessary for the proper assembly and safe use of the appliance.
- Read and follow all warnings and instructions before assembling and using the appliance.
- Follow all warnings and instructions when using the appliance.
- Keep this manual for future reference.

WARNING

- Do NOT store or use gasoline or other flammable liquids or vapors in the vicinity of this or any other appliance.
- An LP cylinder not connected for use shall NOT be stored in the vicinity of this or any other appliance.

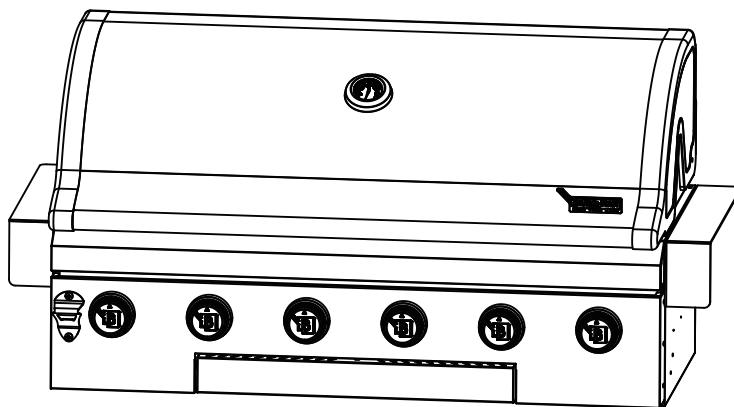
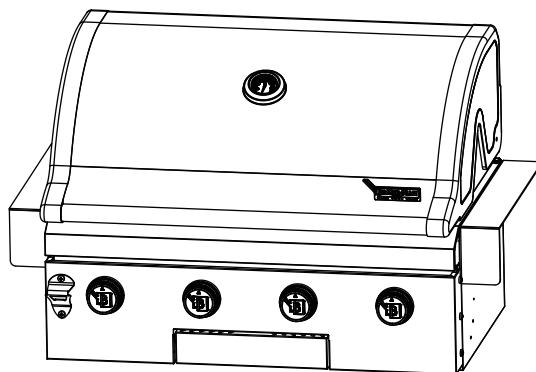

Keep this manual for future reference.

This instruction manual contains important information necessary for the proper assembly and safe use of the appliance.

Read and follow all warnings and instructions before assembling and using the appliance.

Follow all warnings and instruction when using the appliance

DANGER

If you smell gas -

- Shut off gas to appliance.
- Extinguish any open flame.
- Open lid.
- If odor continues, keep away from the appliance and immediately call your gas supplier or your fire department.



Manufacturer:
H&H Asia Limited 27F, No 4013, Shennan Rd, Shenzhen, China

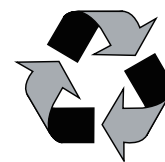

Made from 75% Bagasse
(environmentally-friendly sugar cane
pulp by-product)

Important Safeguards

⚠ DANGER: Failure to follow the dangers, warnings and cautions in this manual may result in serious bodily injury or death, or in a fire or an explosion causing damage to property

⚠ WARNINGS:

- ⚠ This Barbecue is for outdoor use only, and should not be used in a building, garage or any other enclosed area.
- ⚠ For residential use only. This Barbecue is NOT for commercial use.
- ⚠ This BBQ is not intended for and should never be used as a heater. TOXIC fumes can accumulate and cause asphyxiation.
- ⚠ **This Barbecue is safety certified for use in any other location. Modification will result in a safety hazard and will void your warranty.**
- ⚠ Do NOT insert any tool or foreign object into the valve outlet or safety relief valve. You may damage the valve and cause a leak. **Leaking propane may result in an explosion, fire, severe personal injury or death.**
- ⚠ Do NOT block holes in sides or back of Barbecue.
- ⚠ Keep the fuel supply hose away from any heated surfaces.
- ⚠ **A fire causing serious injury or damage to property may occur if the above is not followed exactly.**
- ⚠ **Never use charcoal, lighter fluid, lava rocks, gasoline, kerosene or alcohol with this product.**
- ⚠ Your Barbecue has been checked at all factory connections for leaks. Re-check all connections as described in the "Operating Instructions"- section, as shipping can loosen connections.
- ⚠ Check for leaks even if your unit was assembled for you by someone else.
- ⚠ **Do NOT operate if a gas leak is present. Gas Leaks may cause a fire or explosion.**
- ⚠ You must follow all instructions in the "Checking for Leaks" section **before operating. To prevent fire or explosion hazard when testing for a leak:**
 - a. Always perform a leak test before lighting the BBQ and each time the cylinder is connected for use.
 - b. No smoking. Do NOT use or permit sources of ignition in the area while conducting a leak test.
 - c. Conduct the leak test outdoors in a well-ventilated area.
 - d. **Do NOT use matches, lighters, or a flame to check for leaks.**
 - e. The use of alcohol, prescription or non-prescription drugs may impair the consumer's ability to properly assemble or safely operate the appliance.
 - f. Strong odors, colds, sinus congestion, etc. may prevent the detection of propane. Use caution and common sense when testing for leaks.
 - g. Do NOT use Barbecue until any and all leaks are corrected. If you are unable to stop a leak, disconnect the NG gas supply. Call a gas appliance serviceman or your local NG gas supplier.
- ⚠ This Barbecue is designed to operate at an inlet pressure of 11 inches water column.
- ⚠ **Do NOT store or use gasoline or other flammable liquids or vapors within 25 feet (7.62 m) of this appliance.**
- ⚠ Do NOT use in an explosive atmosphere. Keep Barbecue area clear and **free from combustible materials, gasoline and other flammable vapors and liquids.**
- ⚠ Minimum clearance from sides and back of unit to combustible construction is 30 inches (76.2 cm). Do NOT use this appliance under any type of overhang or roof.
- ⚠ It is essential to keep the Barbecue's valve compartment, burners and circulating air passages clean.
- ⚠ Inspect Barbecue before each use.
- ⚠ Do NOT alter Barbecue in any manner. Any alteration will void your warranty.
- ⚠ Do NOT use the Barbecue unless it is COMPLETELY assembled and all parts are securely fastened and tightened.
- ⚠ Do NOT build this model of Barbecue in any built-in or slide-in construction. **Ignoring this warning could cause a fire or an explosion that can damage property and cause serious bodily injury or death.**
- ⚠ This Barbecue should be thoroughly cleaned and inspected on a regular basis.
- ⚠ Clean and inspect the hose before each use of the appliance. If there is evidence of abrasion, wear, cuts or leaks, the hose must be replaced prior to operation.
- ⚠ Use only the regulator and hose assembly provided. Use only the **placement regulator and hose assembly specified by Captivate Brands USA Inc.**
- ⚠ Use only Captivate Brands USA Inc factory authorized parts. The use of any part that is not factory authorized can be dangerous and will void your warranty.
- ⚠ Do NOT operate this appliance without reading "Operating Instructions" in this manual.
- ⚠ Move gas hoses as far away as possible from hot surfaces and dripping hot grease.
- ⚠ The installation must conform with local codes or, in the absence of local codes, with either the National Fuel Gas and Propane Installation Code, CSA B149.1.

- ▲ Do NOT touch metal parts of Barbecue until they have completely cooled to avoid burns, unless you are wearing protective gear (pot holders, gloves, BBQ mittens, etc.)
- ▲ Do NOT install or use in or on boats or recreational vehicles.
- ▲ **When cooking, fire extinguishing materials should be readily accessible. In the event of an oil/grease fire, do NOT attempt to extinguish with water. Use type BC dry chemical fire extinguisher or smother with dirt, sand or baking soda.**
- ▲ Do NOT use Barbecue i high winds.
- ▲ Never lean over the Barbecue when lighting.
- ▲ Do NOT leave a lit Barbecue unattended. Keep children and pets away from Barbecue at all times.
- ▲ **Do NOT leave Barbecue unattended while preheating or burning off food residue on high. If Barbecue has not been cleaned, a grease fire can occur that may damage the product.**
- ▲ DO NOT place empty cooking vessels on the appliance while in operation.
- ▲ Use caution when placing anything on the Barbecue while the appliance is in operation.
- ▲ Do NOT attempt to move Barbecue when in use. Allow the Barbecue to cool before moving or storing.
- ▲ NG gas supply must be properly disconnected and removed prior to moving this Barbecue.
- ▲ Keep all electrical cords away from a hot Barbecue.
- ▲ After a period of storage and/or nonuse, check for leaks, burner obstructions and inspect for any abrasion, wear or cuts to the hose.
- ▲ Failure to open side shelves while igniting the Barbecue's burners, or not waiting 5 minutes to allow the gas to clear if the Barbecue does not light, **may result in an explosive flame-up.**
- ▲ Always use a meat thermometer to ensure food is cooked to a safe temperature.
- ▲ Use protective gloves when assembling this product.
- ▲ Do NOT force parts together as this can result in personal injury or damage to the product.
- ▲ Never cover entire cooking area with aluminium foil.
- ▲ Deaths, serious injury or damage to property may occur if the above is not followed exactly.
- ▲ Do not modify the appliance.
- ▲ **This appliance must be kept away from flammable materials during use.**
- ▲ This outdoor cooking gas appliance is not intended to be installed in or on boats. For other than RV grills, a statement that this appliance is not intended to be installed in or on recreational vehicles.



WARNING: This product can expose you to chemicals including formaldehyde and lead, which is known to the State of California to cause cancer, and carbon monoxide and lead, which is known to the State of California to cause birth defects or other reproductive harm. For more information go to WWW.P65WARNINGS.CA.GOV.

Expanded

4B

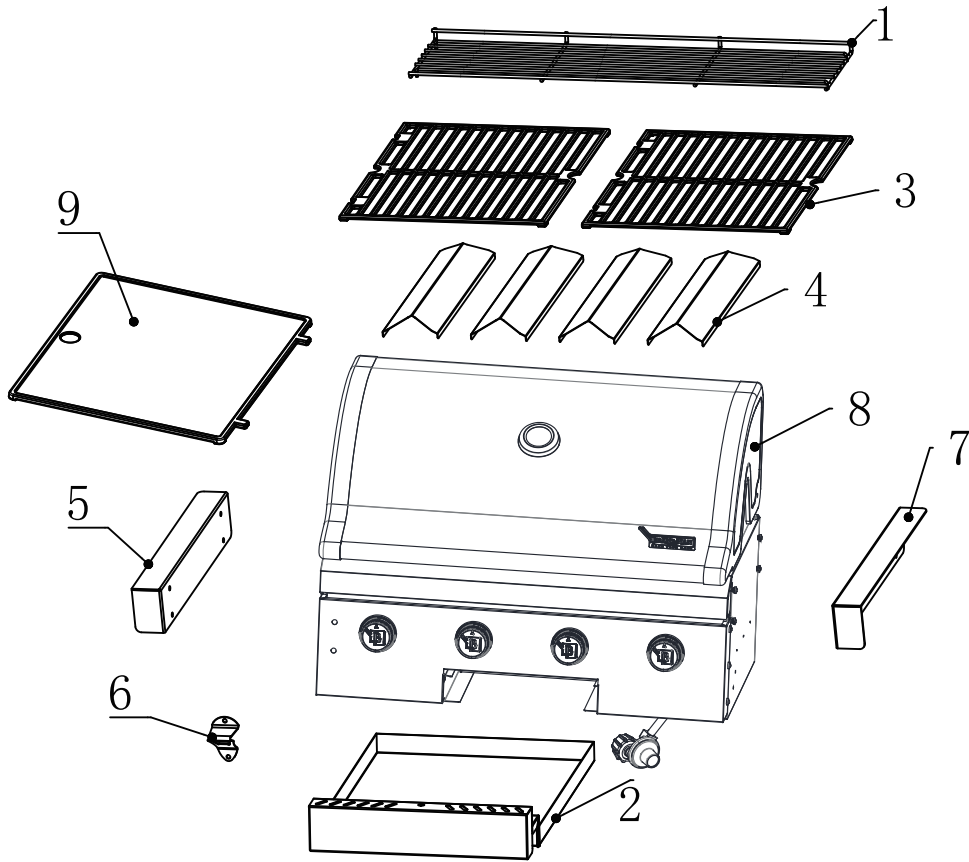



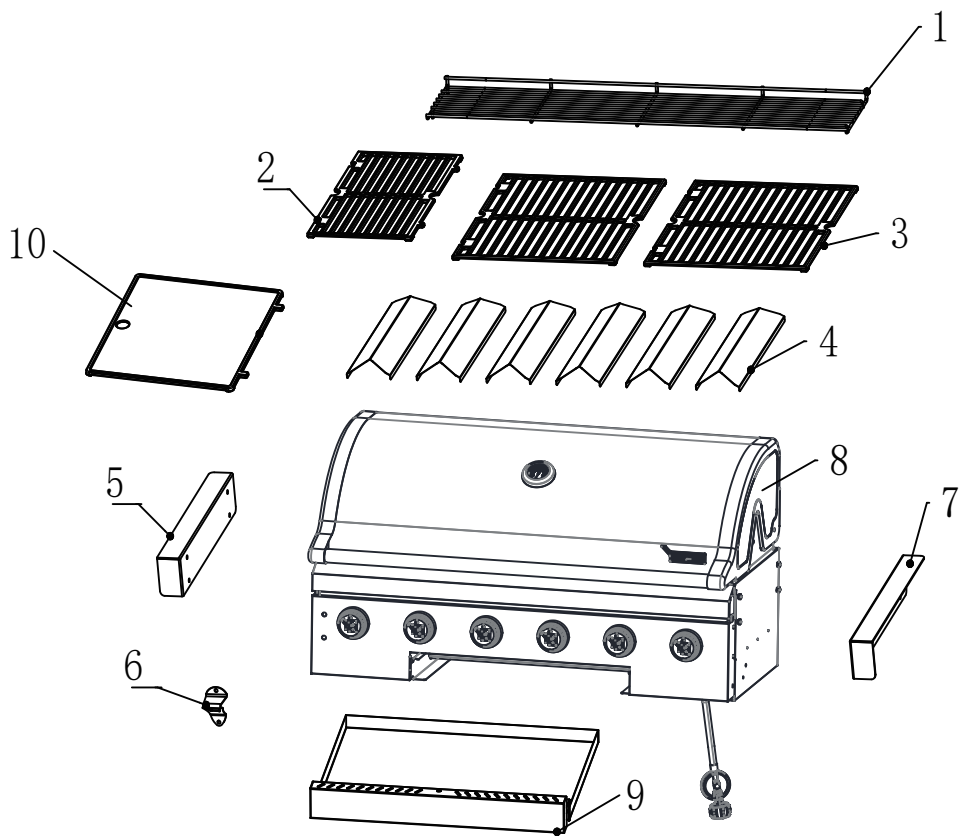





6B





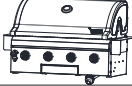



PART LIST

4B

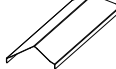
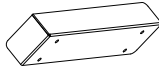
	ITEM DESCRIPTION	QUANTITY	PICTURE
1.	Warming Rack	1	
2.	Grase Tray	1	
3.	Cooking grill	2	
4.	Flame Tamer	4	
5.	In-built Bracket - Left	1	
6.	Bottle opener	1	
7.	In-built Bracket - Right	1	
8.	Barbecue Unit	1	
9.	Hotplate	1	

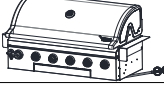
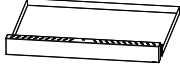
6B

	ITEM DESCRIPTION	QUANTITY	PICTURE
1.	Warming Rack	1	
2.	Cooking grill	1	
3.	Cooking grill	2	
4.	Flame Tamer	6	
5.	In-built Bracket-left	1	
6.	Bottle Opener	1	
7.	In-built Bracket-Right	1	
8.	Barbecue Unit	1	
9.	Grease Tray	1	
10.	Hotplate	1	

ASSEMBLY INSTRUCTIONS

Step 1

4B

- 1) With the help of another person, put the Barbecue unit (8) on a flat area.
- 2) Install the Bottle opener (6) on the barbecue control panel with two screws as shown.
- 3) Attach the In-built Bracket - Left (5) and In-built Bracket - Right (7) with four screws each side as shown below.

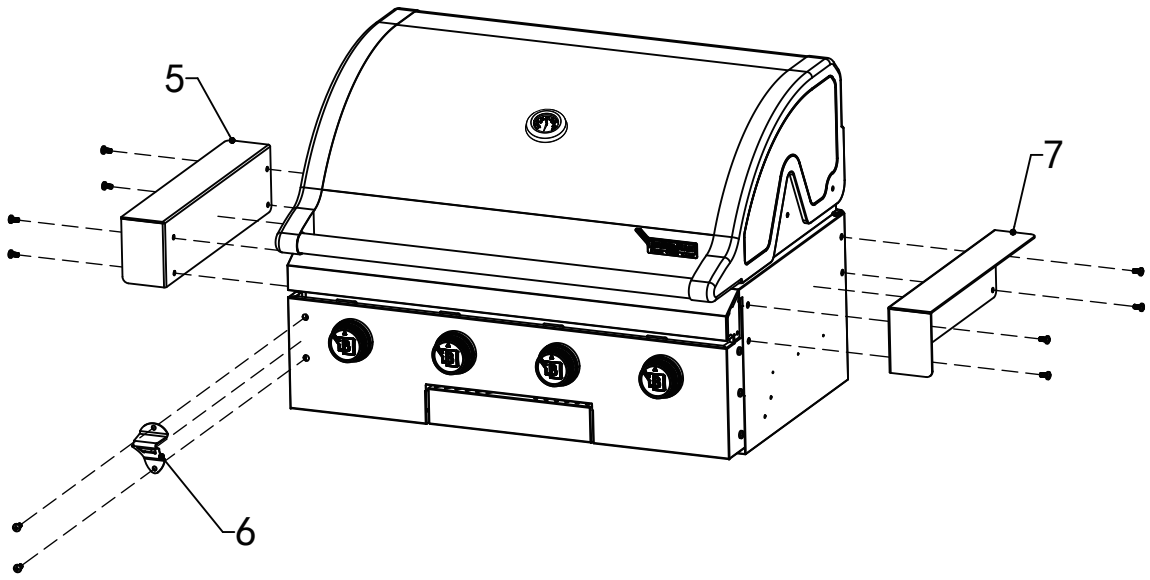

6B

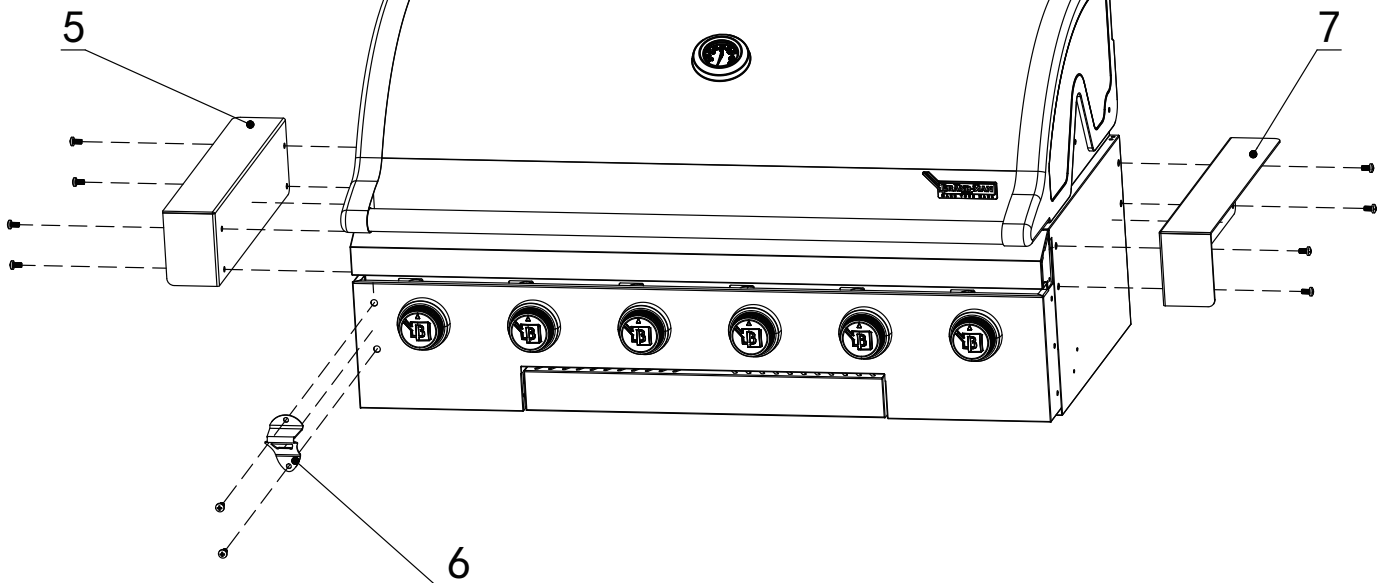

ASSEMBLY INSTRUCTIONS

Step 2

4B

- 1) Open the hood.
- 2) Place Flame Tamers (4) on top of each burner.
- 3) Then place Cooking grills into the firebox as shown.
- 4) Lastly, place the Warming Rack (1).

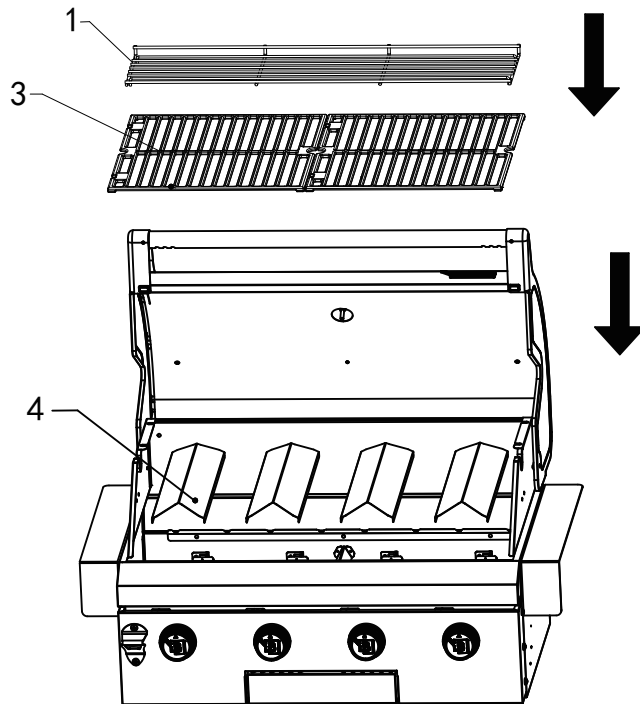

6B

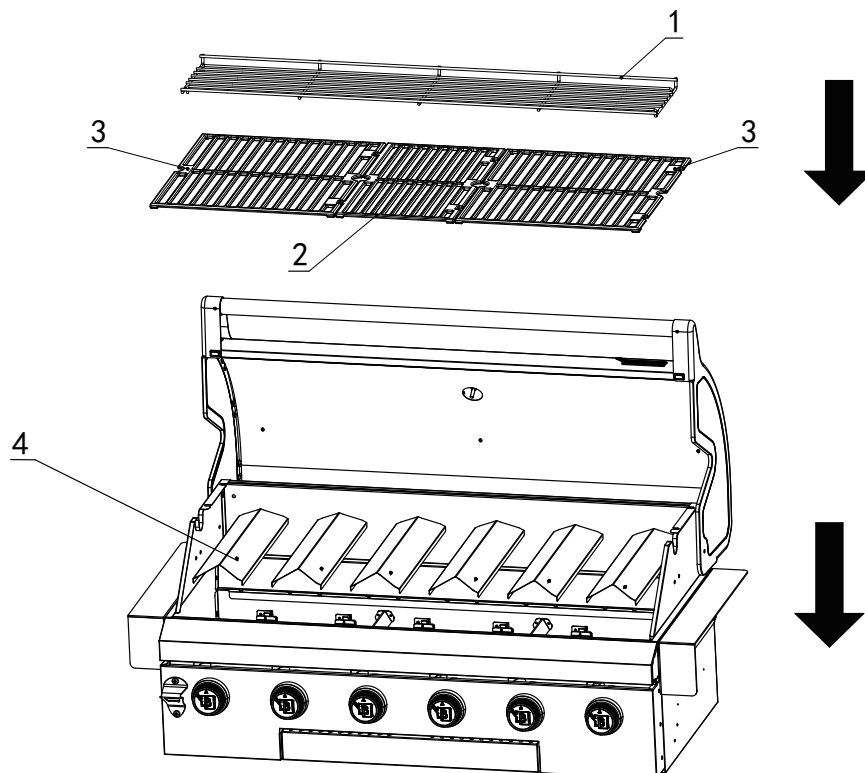

ASSEMBLY INSTRUCTIONS

Step 3

4B

1) Full assembly and recommended In-Built cabinet dimensions.

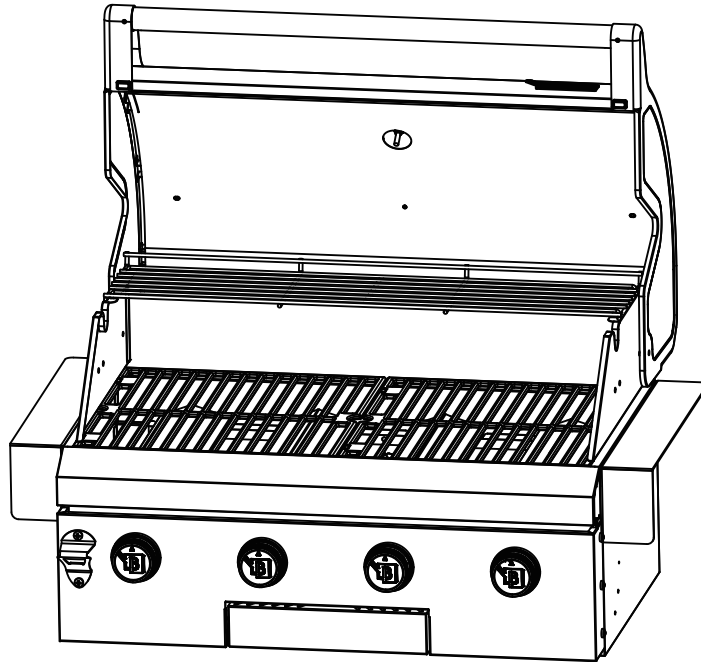

6B

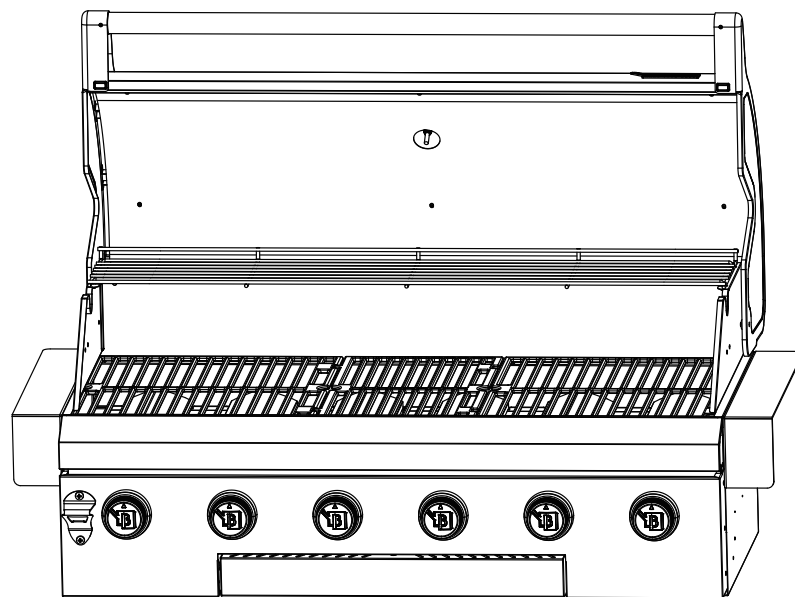

ASSEMBLY INSTRUCTIONS

In-Built cabinet dimensions.

The appliance is only for installation in a built-in enclosure constructed of non-combustible materials.

4B

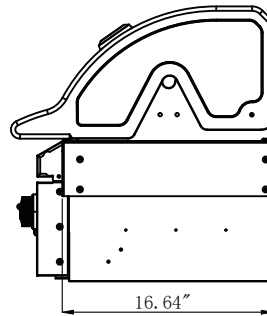
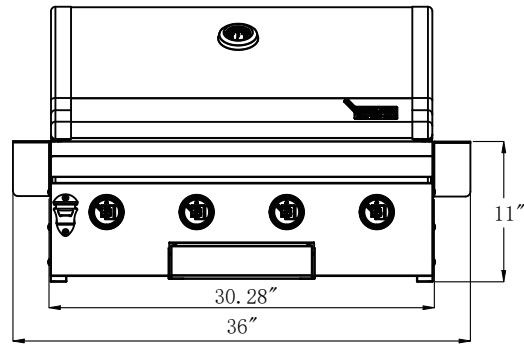
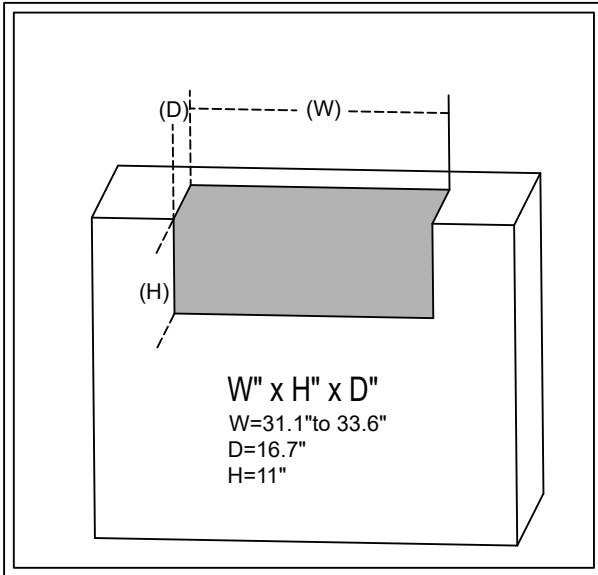

Cut Out Dimensions

W=31.1" to 33.6"
 D=16.7"
 H=11"

Rustler2 BMRUSDI4

6B

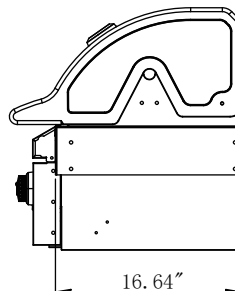
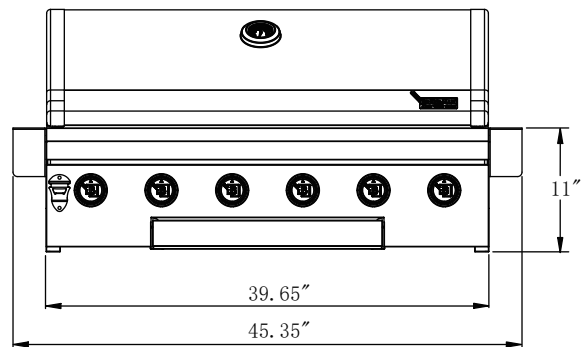
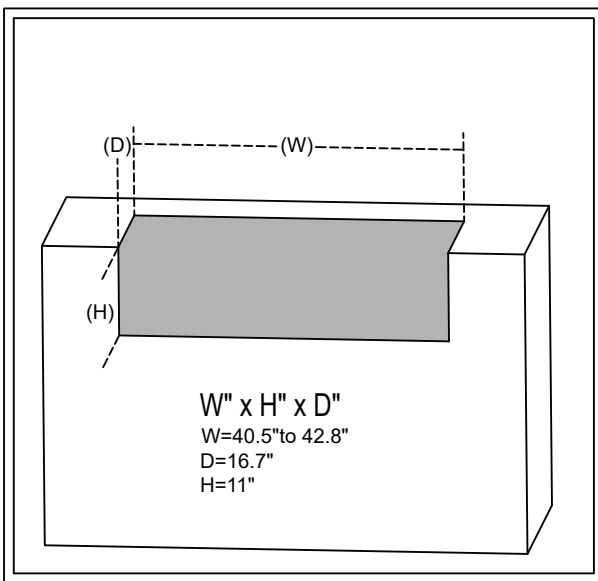

Cut Out Dimensions

W=40.5" to 42.8"
 D=16.7"
 H=11"

Rustler2 BMRUSDI6

ASSEMBLY INSTRUCTIONS (CONTINUE)

Seasoning Barbecue

Important: season your Barbecue cooking surface every time you use it.

Chefs at Japanese steakhouses and short-order restaurants do it all the time, and it is critical for you to do it too. Seasoning helps prolong the life of your Barbecue cooking surface, makes the cooking surface non-stick and helps prevent rust.

Tools needed for seasoning:

- Metal scraper or metal spatula
- Cooking oil, such as vegetable oil or extra virgin olive oil
- Paper towels
- BBQ stone or steel wool
- Finishing oil such as flaxseed oil

CAUTION: Do NOT use corn oil as it contains a high level of sugar, which can caramelize and burn onto the surface.

- 1) While the Barbecue is off and cold, scrap off all excess food or rust using a metal scraper or metal spatula if any. If there are excessive of rust, use a BBQ stone and some cooking oil to scrap the rust out.
- 2) Clean up the Barbecue with paper towels.
- 3) Seasoning the Barbecue by applying a small amount of oil onto the top of Barbecue and spread it around evenly using paper towel. We recommend using flax oil if available.
- 4) Turning the burner to middle high heat and after awhile, the oil will start to smoke and the top of the Barbecue will start to discolor. Let it continue to burn until the surface become dark brown, matt gray or bronze, which take about 30mins and is ready to cook.
- 5) Once finish cooking, let the Barbecue cool down.
- 6) Once the Barbecue has cooled, apply a layer of cooking oil evenly again. This will help prevent rusting.

USING, CONNECTING & DISCONNECTING LP GAS TANK

The installation must conform with local codes or, in the absence of local codes, with either the National Fuel Gas Code, ANSI Z223.1/NFPA 54, or the Natural Gas and Propane Installation Code CSA B149.1, or Propane Storage and Handling Code, CSA B149.2, or the Standard for Recreational Vehicles, ANSI A119.2/NFPA 1192, and CSA 2240 RV Series, Recreational Vehicle Code as applicable.

- ⚠ Use standard flexible tube with length less than 1.5 m. the tube shall be readily visible across its entire length for inspection after installation.

To operate, you will need on precision-filled standard barbecue grill LP gas tank with external valve threads.

- ⚠ CAUTION: LP gas tank must be properly disconnected and removed prior to moving this appliance

Installing LP Gas Tank

1. Before connecting, be sure there is no debris caught in the head of the LP gas tank, head of the regulator valve or in the head of the burner or burner ports.
2. Connect regulator/hose assembly to tank by turning knob clockwise until it stops. The cylinder supply system must be arranged for vapor withdrawal.

Disconnecting LP Gas Tank

1. Before disconnecting, make sure the LP gas tank valve is "CLOSED."
2. Disconnect regulator/hose assembly from LP gas tank by turning knob counterclockwise until it is loose.

- ⚠ CAUTION: LP gas tank must be properly disconnected and removed prior to moving this appliance.

3. Place the protective cap cover on the LP tank and store the tank outdoors in a well ventilated area out of direct sunlight.

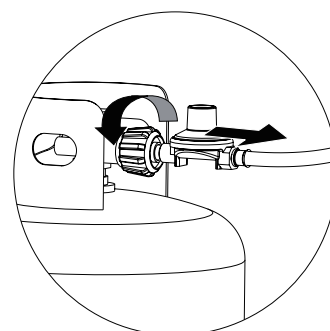
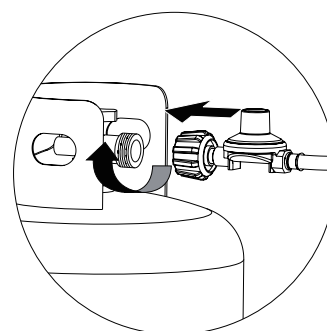
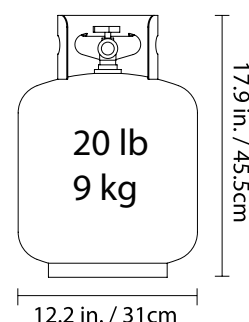

OPERATING INSTRUCTIONS

Burner Connections

1. Make sure the regulator hose and valve connections are securely fastened to the burner and the tank.
2. Visually check the connection between the burner/venturi tube and orifice.
3. Make sure the burner/venturi tube fits over the orifice.

- ⚠ WARNING: Failure to inspect this connection or follow these instructions could cause a fire or an explosion which can cause death, serious bodily injury or damage to property.

4. Please refer to diagram for proper installation (Figure 1).
5. If the burner/venturi tube does not rest flush to the orifice, as shown, please contact Captivate Brands USA Inc for assistance.

Figure 1

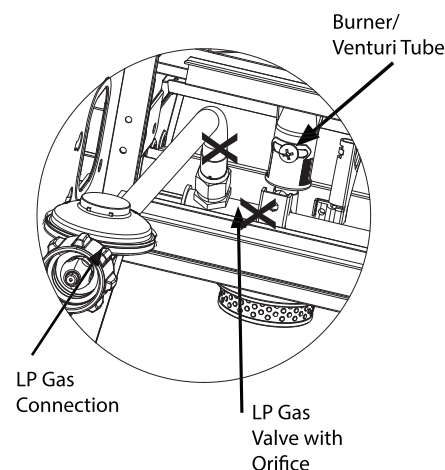

OPERATING INSTRUCTIONS (CONTINUE)

Checking For Leaks

1. Make 2-3 oz. of leak detection solution by mixing one part liquid dish washing soap with three parts water.
2. Make sure control knobs are in the "OFF" position (Figure 2).
3. Connect LP gas tank per "Installing LP Gas Tank" section.
4. Turn LP gas tank valve to "OPEN."
5. Spoon several drops of solution, or use a squirt bottle, at all "X" locations (Figures 1 and 3).
 - a. If any bubbles appear, turn LP gas tank valve to "CLOSED," reconnect and re-test.
 - b. If you continue to see bubbles after several attempts, turn LP gas tank valve to "CLOSED" and disconnect LP gas tank, per "Disconnecting LP Gas Tank" section. Contact Captivate Brands USA Inc for assistance.
 - c. If no bubbles appear after one minute, turn LP gas tank valve to "CLOSED," wipe away solution and proceed.

Operating Main Burners

First Use

1. Make sure all labels, packaging and protective films have been removed from the Barbecue.
2. Light Barbecue per "Lighting" section.
3. Remove manufacturing oils before cooking on this Barbecue for the first time.
4. Season your Barbecue cooking surface per "Seasoning Barbecue" section.

Lighting

- ⚠ **CAUTION:** Keep outdoor gas cooking appliance area clear and free from combustible materials, gasoline and other flammable vapors and liquids.
- ⚠ **CAUTION:** Do NOT obstruct the flow of combustion and ventilation air.
- ⚠ **CAUTION:** Check and clean burner/venturi tubes for insects and insect nests. A clogged tube can lead to a fire.
- ⚠ **CAUTION:** Do NOT use non-stick cooking sprays because they contain a lot of water and can burn onto the Barbecue, damaging the surface.
- ⚠ **CAUTION:** Do NOT use corn oil as it contains a high level of sugar, which can caramelize and burn onto the surface.

1. Check for obstructions of airflow to the burners. Spiders, insects and webs can clog the burner/venturi tube. A clogged burner tube can lead to a fire.
2. All control knobs must be in the "OFF" position (Figure 2).
3. Connect LP gas tank per "Installing LP Gas Tank" section.

Figure 2

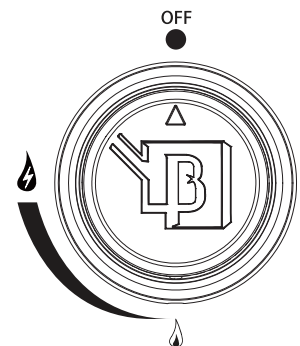

Figure 3

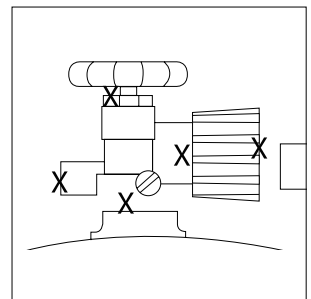
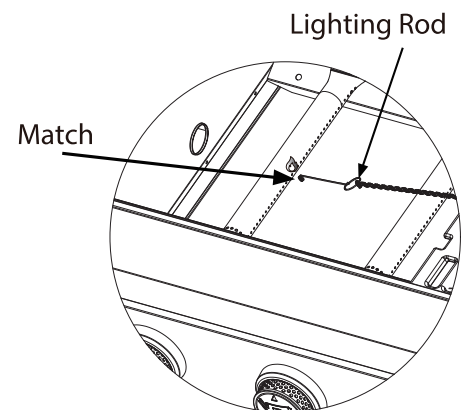

Figure 4



OPERATING INSTRUCTIONS (CONTINUE)

- Turn LP gas tank valve to "OPEN."
- Push and turn any control knob to 🔥 (HIGH). The burner should light. If it does not, repeat up to three times.
- If ignition does not occur in 5 seconds, turn burner control knob "OFF," wait 5 minutes, and repeat lighting procedure.
- If igniter does not light burner, use a lit match secured with the Lighting Hook (included with the Barbecue) to light burners. Position lit match near side of burner (Figures 4).

Important: Always use the Lighting Hook (included) when lighting burners with a match.

- After lighting, observe the burner flame. Make sure all burner ports are lit and flame height matches illustration (Figure 5).

Note: Each burner lights independently - repeat steps 5-9 for the other burners.

⚠ CAUTION: If burner flame goes out during operation, immediately turn the control knobs to the "OFF" position, turn the LP gas tank valve to "CLOSED" and open lid to let the gas clear for 5 minutes before relighting.

Turning Off

- Turn LP gas tank valve to "CLOSED".
- Turn all control knobs clockwise to OFF position.

Note: A "poof" sound is normal as the last of the LP gas is burned.

- Disconnect LP gas tank per "Disconnecting LP Gas Tank" section.

Controlling Flare-ups

CAUTION:

- If a grease fire develops, turn control knobs to the "OFF" position and LP gas tank valve to "CLOSED." Do NOT use water on a grease fire. This can cause the grease to splatter and could result in serious burns, bodily harm or other damage.**
- Do NOT leave Barbecue unattended while preheating or burning off food residue on 🔥 (HIGH). If Barbecue has not been cleaned, a grease fire can occur.**

WARNING: When cooking, fire extinguishing materials should be readily accessible. In the event of an oil/grease fire, use type BC dry chemical fire extinguisher or smother with dirt, sand or baking soda.

Do NOT attempt to extinguish with water.

Flare-ups are a part of cooking meats on a Barbecue and add to the unique flavor of grilling.

Excessive flare-ups can over-cook your food and be dangerous.

Important: Excessive flare-ups result from the build-up of grease in the grease cup.

If a grease fire occurs, turn the control knob(s) to "OFF" until the grease burns out.

If excessive flare-ups occur, DO NOT pour water onto the flames.

Minimize Flare-ups:

- Trim excess fat from meats prior to cooking.
- Cook high fat content meats on 🔥 (LOW) setting or indirectly.
- Ensure that your Barbecue is on a hard, level, non-combustible surface and the grease is allowed to drain into grease receptacle.

NOTE: Using pan larger than 240mm diameter in capacity could exceed weight limit of the side burner shelf

Figure 5

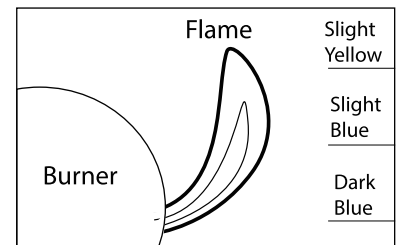

CLEANING AND CARE

⚠ CAUTION:

1. All cleaning and maintenance should be done when Barbecue is cool and with the fuel supply disconnected.
2. Do NOT clean any Barbecue part in self-cleaning oven. The extreme heat will damage the finish.
3. Do Not enlarge valve orifices or burner ports when cleaning the valves or burners.

Notices

1. This Barbecue should be thoroughly cleaned and inspected on a regular basis.
2. Abrasive cleaners will damage this product.
3. Never use oven cleaner to clean any part of Barbecue.

Before Each Use:

1. Keep the Barbecue area clean and free from any combustible materials, gasoline, and other flammable vapors and liquids.
2. Do NOT obstruct the flow of the combustion of LP gas and the ventilation of air.
3. Keep the ventilation opening(s) of the LP gas tank area free and clear from debris.
4. Visually check the burner flames to make sure your Barbecue is working properly (Figure 6).
5. See sections below for proper cleaning and seasoning instructions.
6. Check for obstructions of airflow to the burners. Spiders, insects and webs can clog the burner/venturi tube. A clogged burner tube can lead to a fire.

Cleaning Cart Surfaces

1. Wipe surfaces clean with mild dish washing detergent or baking soda mixed with water.
2. For stubborn surfaces, use a citrus-based degreaser and a nylon scrubbing brush.
3. Rinse clean with water.
4. Allow to air dry.

Cleaning Main Burners

1. Turn LP gas tank valve to "CLOSED."
 2. Turn all control knobs clockwise to the " OFF" position.
- Note: A "poof" sound is normal as the last of the gas is burned.
3. Disconnect LP gas tank per "Disconnecting LP Gas Tank" section
 4. Remove Barbecue by lifting it off the cart.

5. Remove burners by removing the fasteners, which secure the burners to the frame bottom.
6. Lift burners up and away from gas valve orifice.
7. Disconnect wire from spark electrode.

Figure 6

Burner Flame Conditions

Use this chart to see if your burners need to be cleaned

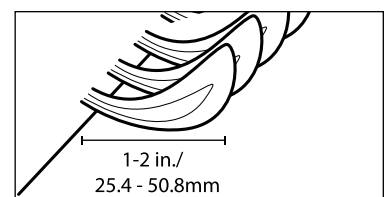

Normal: Soft blue flames with yellow tips between 1 in- 2 in. height

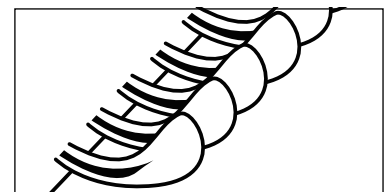

Needs cleaning: Noisy with hard blue flames

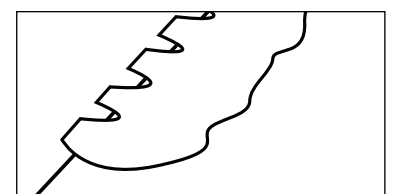

Has to be replaced: Wavy with yellow flames

CLEANING AND CARE

- Clean venturi of each burner with small bottle brush or compressed air.
- Remove all residue and dirt from burner surface.
- Clean any clogged ports with a stiff wire (such as an opened paper clip).
- Inspect burners for any damage (cracks or holes). If damage is found, replace with new burner(s) from manufacturer.
- Re-install burner(s). Checking to insure that gas valve orifice is correctly positioned inside each burner/venturi tube. Also, check position of spark electrode.
- Connect wire to spark electrode.
- Replace Barbecue.
- Connect LP gas tank per "Installing LP Gas Tank" section.
- Perform leak test per "Checking for Leaks" section.

Before Storing

- Turn LP gas tank valve to "CLOSED."
- Turn all control knobs clockwise to the "OFF" position.
Note: A "poof" sound is normal as the last of the gas is burned.
- Disconnect LP gas tank per "Disconnecting LP Gas Tank" section.
- Clean all surfaces.
- Lightly coat the burner(s) with cooking oil to prevent excess rusting.
- Season your Barbecue cooking surface per "Seasoning Barbecue" section.
- If storing the Barbecue indoors, disconnect the LP tank per "Disconnecting LP Gas Tank" section.
- Place the protective cap cover on the LP tank and store the tank outdoors in a wellventilated area out of direct sunlight.
- If storing the Barbecue indoors, cover the Barbecue and store in a cool dry place.
- If storing the Barbecue outdoors, cover the Barbecue with a Barbecue cover for protection from the weather.

Seasoning Barbecue

Important: season your Barbecue cooking surface every time you use it.

Chefs at Japanese steakhouses and short-order restaurants do it all the time, and it is critical for you to do it too. Seasoning helps prolong the life of your Barbecue, makes the cooking surface non-stick and helps prevent rust.

Tools needed for seasoning:

- Metal scraper or metal spatula
- Cooking oil, such as vegetable oil or extra virgin olive oil
- Paper towels
- BBQ stone or steel wool
- Finishing oil such as flaxseed oil

⚠ CAUTION: Do NOT use corn oil as it contains a high level of sugar, which can caramelize and burn onto the surface.

CLEANING AND CARE

First Use

1. Light Barbecue per "Lighting" section.
2. Keep burners on 🔥 (HIGH) for 15 minutes.
3. Turn Barbecue off per "Turning Off" section.
4. Allow Barbecue to cool, but still be slightly warm.
5. Wipe off Barbecue surface, inner and outer walls with paper towels until clean.

Note: While drying you may notice the towel may have some discoloration. This is normal.

6. Apply finishing oil onto Barbecue surface, inner and outer walls and evenly coat with rolled up paper towels.
7. Repeat this process at least twice.

After Each Use

1. Turn Barbecue off per "Turning Off" section.
2. While the Barbecue is still warm, gently scrape off all food residue with a scraper.
3. Wipe down Barbecue surface, inner and outer walls with a towel or paper towels.
4. For stubborn food residue:
 - a. Light Barbecue per "Lighting" section.
 - b. Apply cooking oil onto Barbecue surface.
 - c. Allow oil to "boil" food residue off.
 - d. Repeat steps 1 through 3.
 - e. If necessary, use a BBQ stone and scrub the food residue off.
 - f. Continue with "Seasoning Barbecue" instructions.
5. Wipe off Barbecue surface, inner and outer walls with paper towels until clean.

Note: While drying you may notice the towel has some discoloration. This is normal.
6. Apply finishing oil onto Barbecue surface, inner and outer walls and evenly coat with rolled up paper towels.
7. Light Barbecue per "Lighting" section.
8. Keep burners on and 🔥 (HIGH) for 15 minutes or until finishing oil starts to smoke.
9. Turn Barbecue off per "Turning Off" section.
10. Repeat steps 6-9 a minimum of 2 additional times.
11. Following "Before Storing" section.

Refurbish the Barbecue Surface

1. If Barbecue is off, light per "Lighting" section for 10 minutes. Then turn Barbecue off per "Turning Off" section.
2. If Barbecue is on, turn Barbecue off per "Turning Off" section.
3. While the Barbecue is still warm, use a scraper or metal spatula to remove as much rust and food residue as you can from the Barbecue surface, inner and outer walls.
4. Apply a liberal amount of cooking oil onto the Barbecue surface.
5. Using a BBQ stone, scrub the Barbecue surface. Apply additional cooking oil as need.
6. Wipe off Barbecue surface, inner and outer walls with paper towels.
7. Repeat steps 3-5 until paper towels no longer show any rust.
8. Apply finishing oil onto Barbecue surface, inner and outer walls and evenly coat with rolled up paper towels.
9. Light Barbecue per "Lighting" section.
10. Keep burners on 🔥 (HIGH) for 15 minutes or until finishing oil starts to smoke.
11. Turn Barbecue off per "Turning Off" section.
12. Repeat steps 7-10 until the surface has a nice dark color.
13. Following "Before Storing" section.

REPLACEMENT PARTS

For replacement parts, please contact Captivate Brands USA Inc via 855-200-8445 ext 102

WARRANTY

Captivate Brands USA Inc warrants to the original retail purchaser of this product, and to no other person, that if this product is assembled, maintained, and operated in accordance with the printed instructions accompanying it, then for a period of five (5) year from the date of purchase, the product's components shall be free from defects in material and workmanship, except for the cooking surface which is not covered by the Limited Warranty. Captivate Brands USA Inc may require reasonable proof of your date of purchase. Therefore, you should retain your sales slip or invoice. This Limited Warranty shall be limited to the repair or replacement of parts, which prove defective under normal use and service and which Captivate Brands USA Inc shall determine in its reasonable discretion upon examination to be defective. Before returning any parts, you should contact Captivate Brands USA Inc's Customer Care Department using the contact information listed below. If Captivate Brands USA Inc confirms, after examination, a defect covered by this Limited Warranty in any returned part, and if Captivate Brands USA Inc approves the claim, Captivate Brands USA Inc will replace such defective part without charge. If you return defective parts, transportation charges must be prepaid by you. Captivate Brands USA Inc will return replacement parts to the original retail purchaser, freight or postage prepaid.

This Limited Warranty does not cover any failures or operating difficulties due to accident, abuse, misuse, alteration, misapplication, improper installation or improper maintenance or service by you or any third party, or failure to perform normal and routine maintenance on the product as set out in this owner's manual. In addition, the Limited Warranty does not cover damage to the finish, such as scratches, dents, discoloration, rust or other weather damage, after purchase.

This Limited Warranty is in lieu of all other express warranties. Captivate Brands USA Inc disclaims all warranties for products that are purchased from sellers other than authorized retailers or distributors, including the warranty of merchantability or the warranty of fitness for a particular purpose. CAPTIVATE BRANDS USA INC ALSO DISCLAIMS ANY AND ALL IMPLIED WARRANTIES, INCLUDING WITHOUT LIMITATION THE IMPLIED WARRANTIES OF MERCHANTABILITY AND FITNESS FOR A PARTICULAR PURPOSE. CAPTIVATE BRANDS USA INC SHALL HAVE NO LIABILITY TO PURCHASER OR ANY THIRD PARTY FOR ANY SPECIAL, INDIRECT, PUNITIVE, INCIDENTAL, OR CONSEQUENTIAL DAMAGES.

Captivate Brands USA Inc further disclaims any implied or express warranty of, and assumes no responsibility for, defects in workmanship caused by third parties.

This Limited Warranty gives the purchaser specific legal rights; a purchaser may have other rights depending upon where he or she lives. Some jurisdictions do not allow the exclusion or limitation of special, incidental or consequential damages, or limitations on how long a warranty lasts, so the above exclusion and limitations may not apply to everyone.

Captivate Brands USA Inc does not authorize any person or company to assume for it any other obligation or liability in connection with the sale, installation, use, removal, return, or replacement of its equipment, and no such representations are binding on Captivate Brands USA, Inc.

Captivate Brands USA, Inc.

25541 Arctic Ocean Drive Lake Forest, CA. 92630

If you have any questions or problems, you can

contact our customer service at

855-200-8445 ext 102 or help@supportandspares.com

from 9AM to 5PM Monday to Friday (Pacific)

All emails and voice-mail calls will be answered within 24 hours.

TROUBLESHOOTING

Problem	Possible Cause	Prevention/Cure
Burner will not light using igniter	LP gas tank valve is closed	Make sure regulator is securely attached to the LP gas tank per "Installing LP Gas Tank," then turn LP gas tank valve to "OPEN"
	LP gas tank low or empty	Exchange, refill or replace LP gas tank
	LP gas	1. Turn LP gas tank valve to "CLOSED" 2. Wait 5 minutes for gas to clear 3. Follow "Checking for Leaks" section
	Wires or electrode covered with cooking residue	Clean wire and/or electrode with rubbing alcohol
	Electrode and burners are wet	Wipe dry with cloth
	Electrode cracked/broken - sparks at crack	Replacement part(s) may be needed - contact Customer Care
	Wire loose or disconnected	Reconnect wire or replacement part(s) may be needed - contact Customer Care
	Wire is shorting (sparking) between igniter and electrode Bad igniter	Replacement part(s) may be needed - contact Customer Care Replacement part(s) may be needed - contact Customer Care
Burner will not light with match	No gas flow	Check if LP gas tank is empty A. If empty, exchange, refill or replace LP gas tank B. If LP gas tank is not empty, refer to "Sudden drop in gas flow or reduced flame height" (see below)
	LP gas tank is low or empty	Exchange, refill or replace LP gas tank
	LP gas	1. Turn LP gas tank valve to "CLOSED" 2. Wait 5 minutes for gas to clear 3. Follow "Checking for Leaks" section
	Coupling nut and regulator not fully connected	Turn the coupling nut about one-half to three-quarters additional turn until solid stop. Tighten by hand only - do NOT use tools
	Obstruction of gas flow	1. Clear burner/venturi tube 2. Check for bent or kinked hose
	Disengagement of burner to valve	Re-engage burner and valve
	Spider webs or insect in venturi Burner ports clogged or blocked	Clean burner/venturi tube Clean burner ports
Sudden drop in gas flow or reduced flame height	Out of gas	Exchange, refill or replace LP gas tank
	Overfilling prevention device may have been activated	1. Turn control knob to "OFF" 2. Wait 30 seconds and light Barbecue 3. If flames are still too low, reset the overfilling prevention device: a. Turn control knob(s) "OFF" b. Turn LP gas tank valve to "CLOSED" c. Disconnect regulator d. Turn control knobs to ⚡ (HIGH) e. Wait 1 minute f. Turn control knobs to "OFF" g. Reconnect regulator and leak check connections, being careful not to fully open valve h. Light Barbecue per "Lighting" section
Sudden drop in gas flow or reduced flame height	Burner ports are clogged or blocked	Clean burner ports
Flame is yellow or orange	New burner may have residual manufacturing oils	Burn Barbecue for 15 minutes on ⚡ (HIGH) with the lid closed
	Spider webs or insect nest in venturi	Clean venturi
	Food residue, grease, etc. on burners	Clean burner
	Poor alignment of valve to burner/venturi tube	Ensure burner/venturi tube is properly engaged with valve
Flame goes out	High or gusting winds	Do not use Barbecue in high wind
	Low on LP Gas	Exchange, refill or replace LP gas tank
	Overfilling prevention device may have been activated	Refer to "Sudden drop in gas flow or reduced flame height" (see above)
Flare-up	Grease buildup	Remove and clean Barbecue parts per "Cleaning and Care" Section
	Excess fat in meat	Trim fat from meat before cooking
	Excessive cooking temperature	Adjust to lower cooking temperature
Persistent grease fire	Excessive cooking temperature	1. Turn control knobs to "OFF" 2. Turn LP gas tank valve to "CLOSED" 3. Leave lid in closed position and let fire burn out 4. After Barbecue cools, remove and clean all parts per "Cleaning and Care" section
Flashback (fire in burner tube(s))	Burner and/or burner/venturi tube are blocked	Adjust to lower cooking temperature
Barbecue Surface	Barbecue has started to rust	With use the Barbecue surface will rust, this is normal. Follow the "Refurbish the Barbecue Surface" instructions in the "Seasoning Barbecue" section to season your Barbecue surface.
	Barbecue surface looks dull	The cooking surface has gotten too hot, and is no longer seasoned. Season grill per "Seasoning Barbecue" section

For assistance, please contact Captivate Brands USA Inc via 855-200-8445 ext 102