

# Round Coffee Table

## Instruction Manual

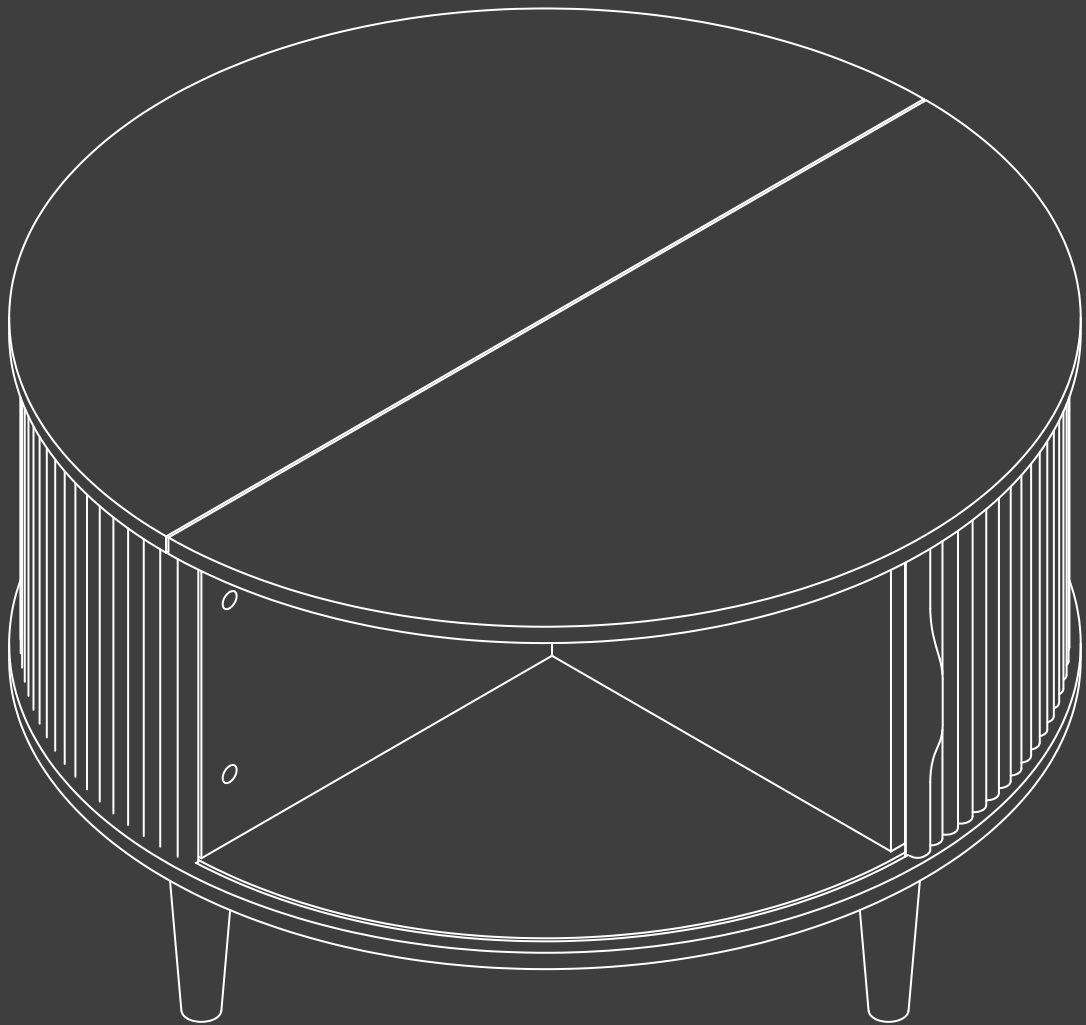

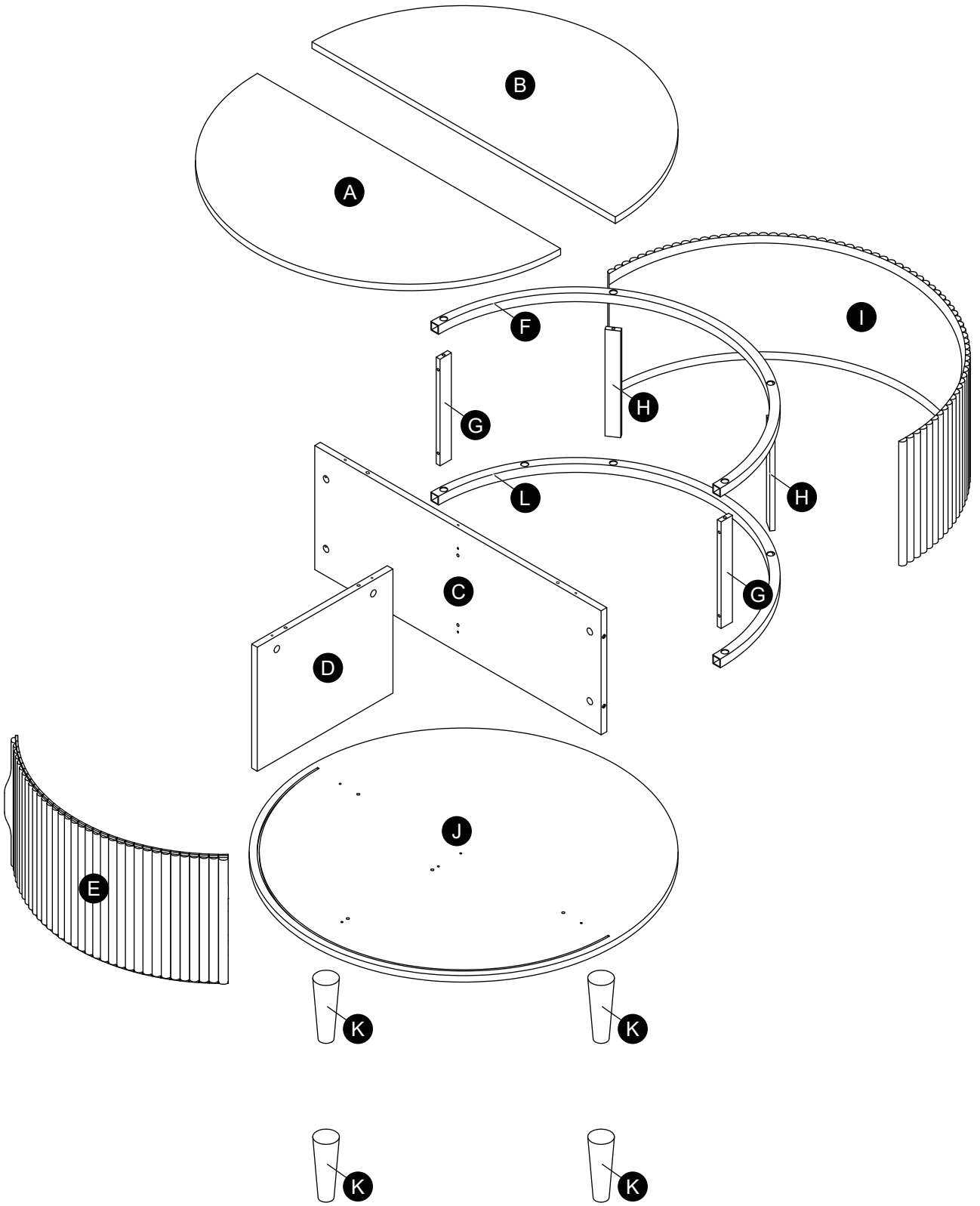

# PARTS LIST

---

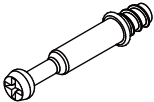

M6x35mm

**1** x9



Φ15x9.5mm

**2** x9

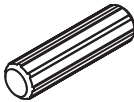

Φ8x30mm

**3** x10

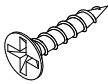

Φ4x12mm

**4** x36



Φ4x40mm

**5** x19

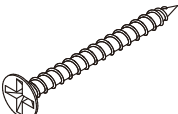

Φ4x30mm

**6** x3



**7** x4

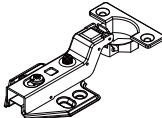

**8** x2

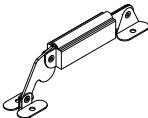

**9** x1

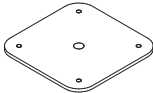

**10** x4



**11** x4

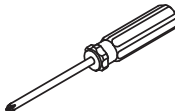

**12** x1

# ASSEMBLY INSTRUCTION

## Step 1

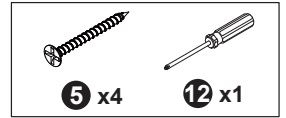
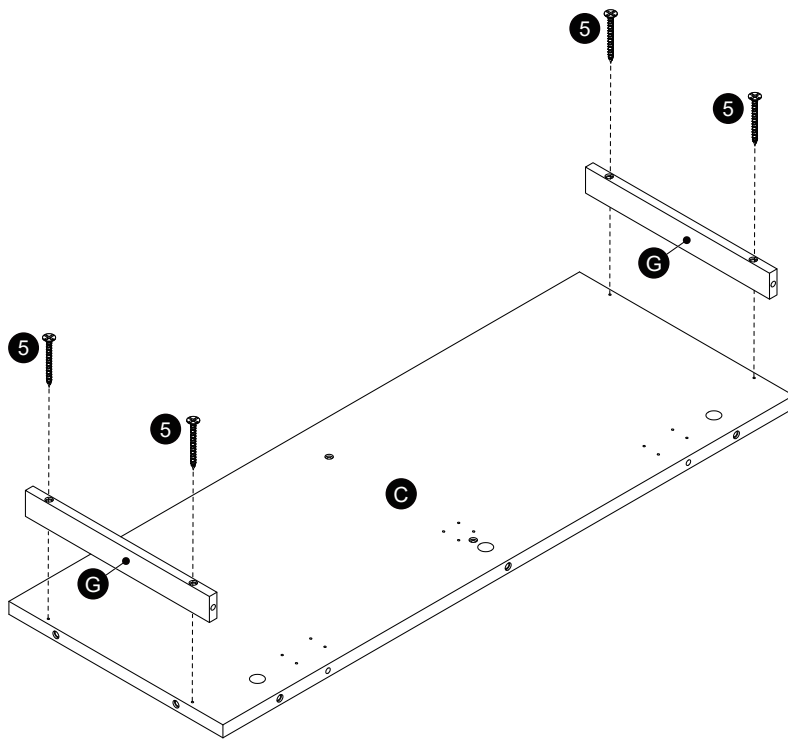

## Step 2

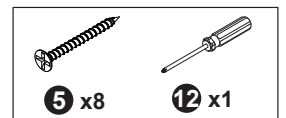
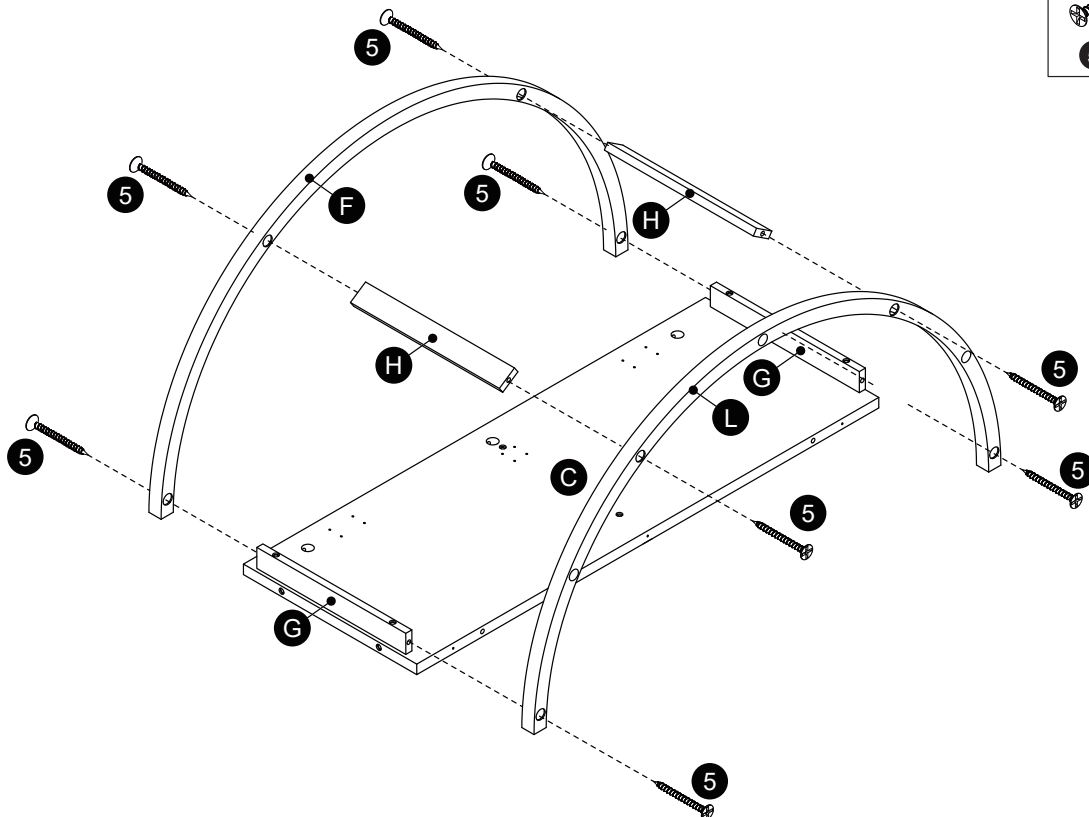

# Step 3

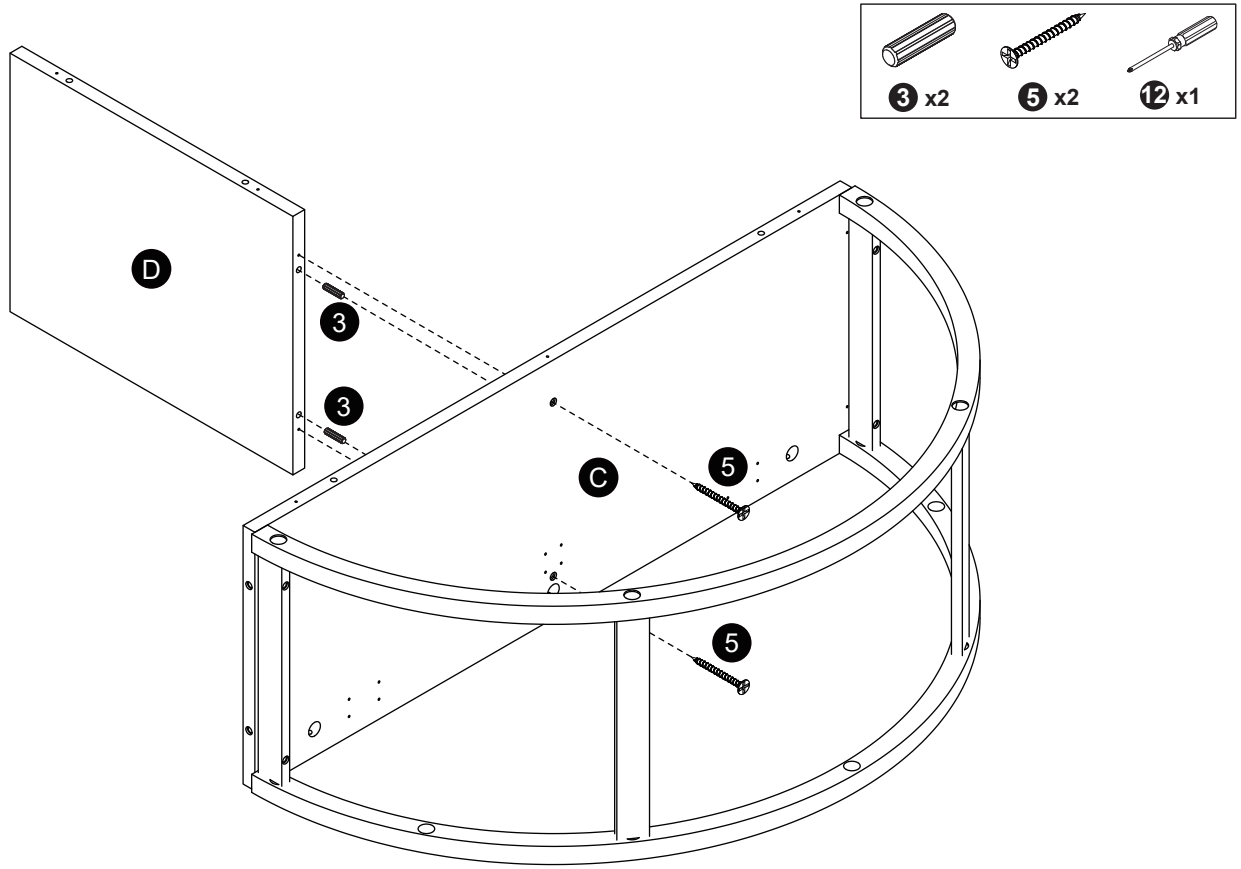

# Step 4

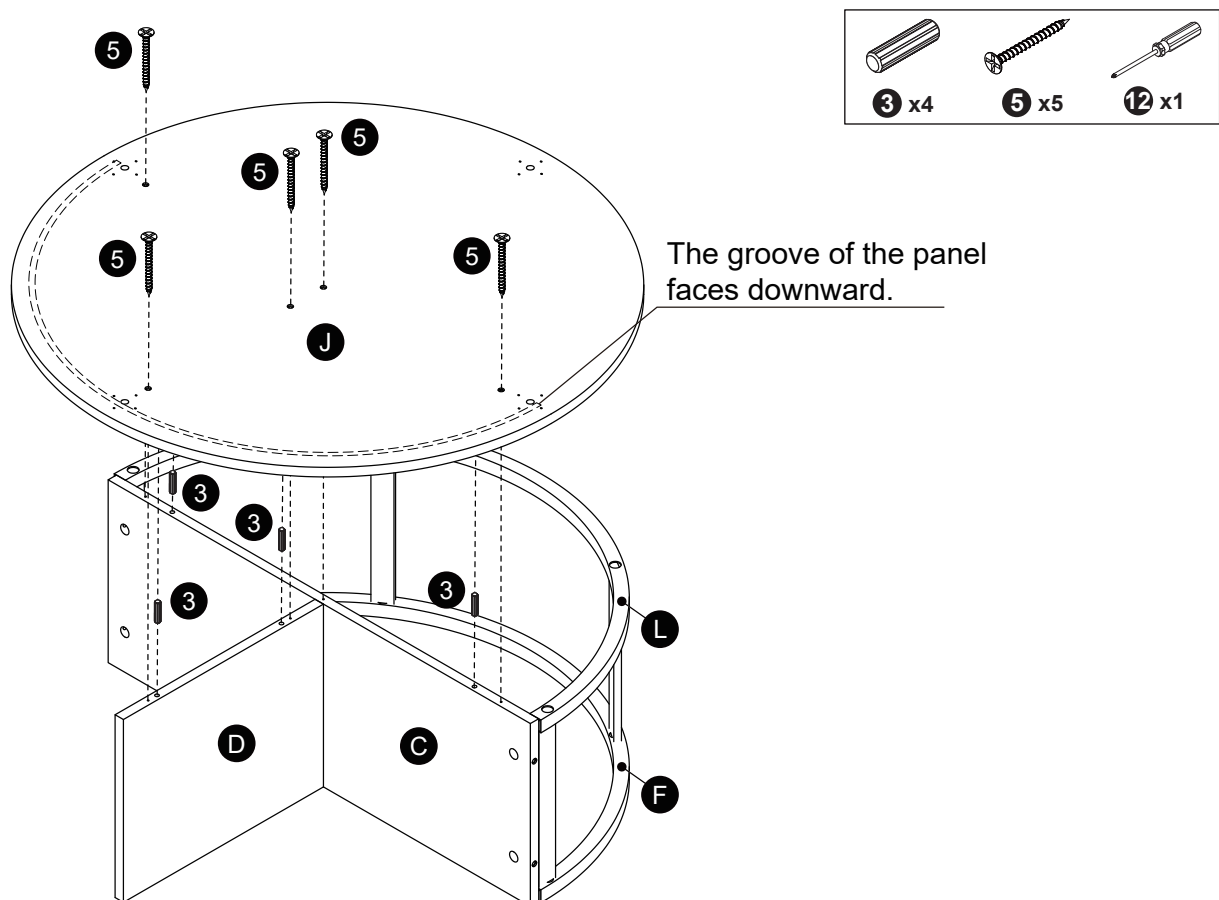

# Step 5

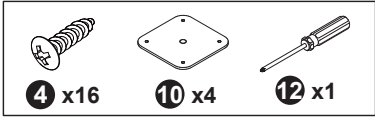
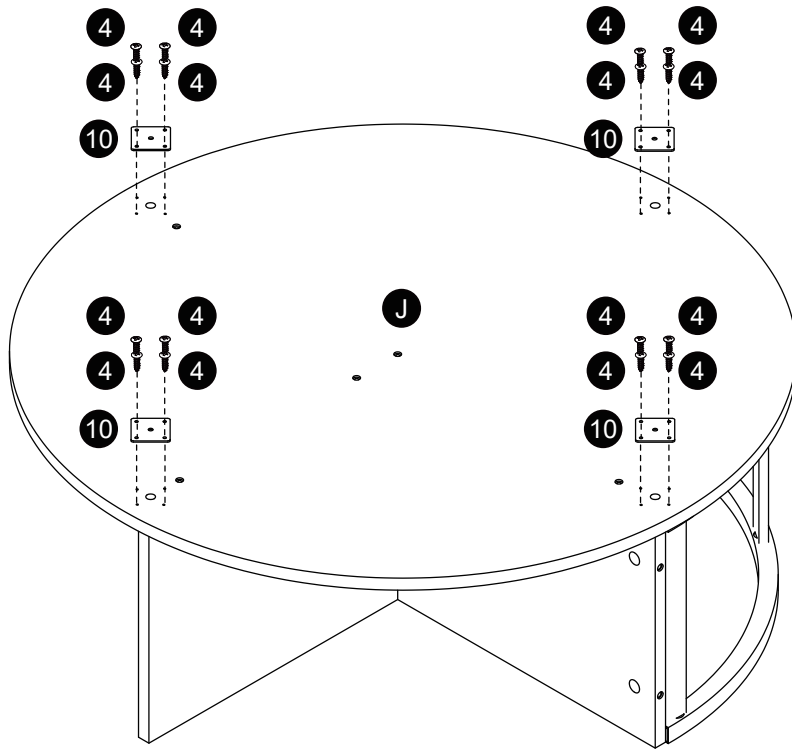

# Step 6

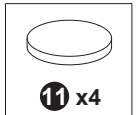
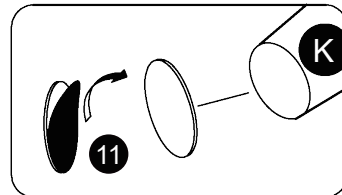
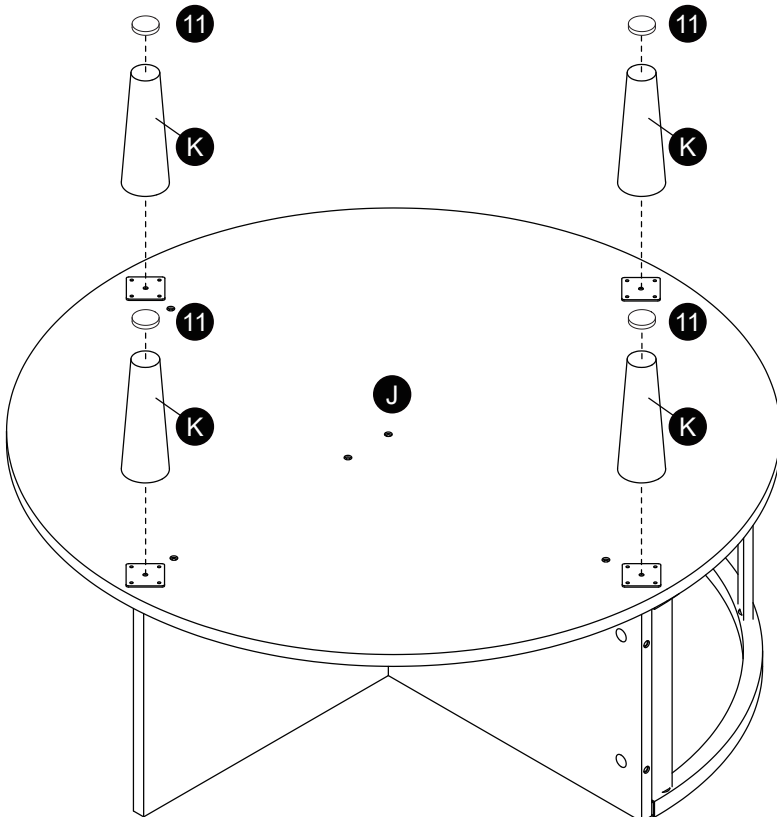

# Step 7

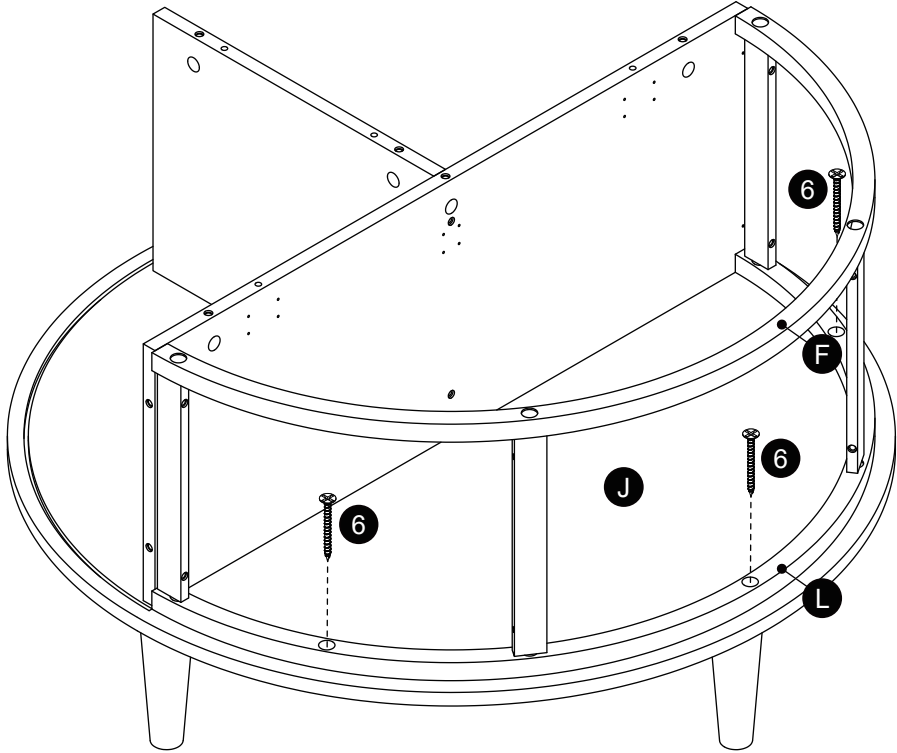
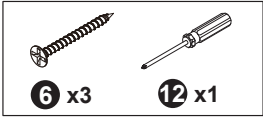

# Step 8

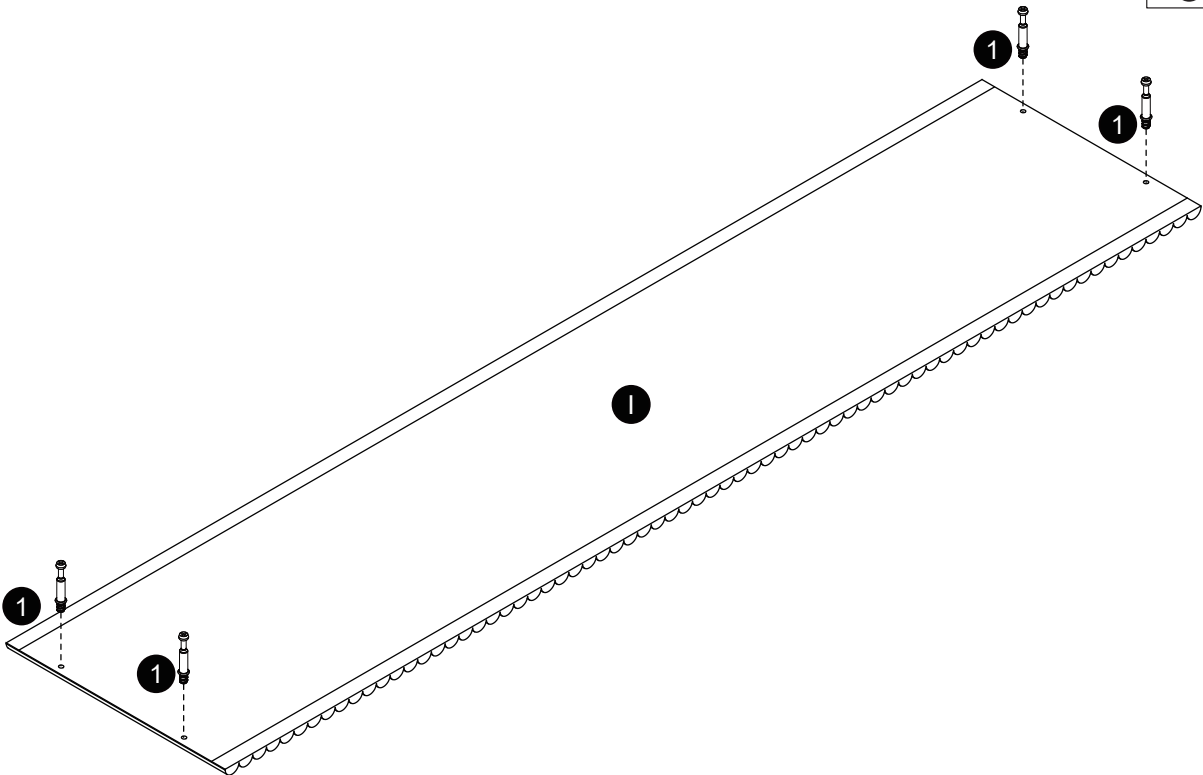
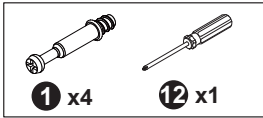

# Step 9

I .First insert the screw on one side.

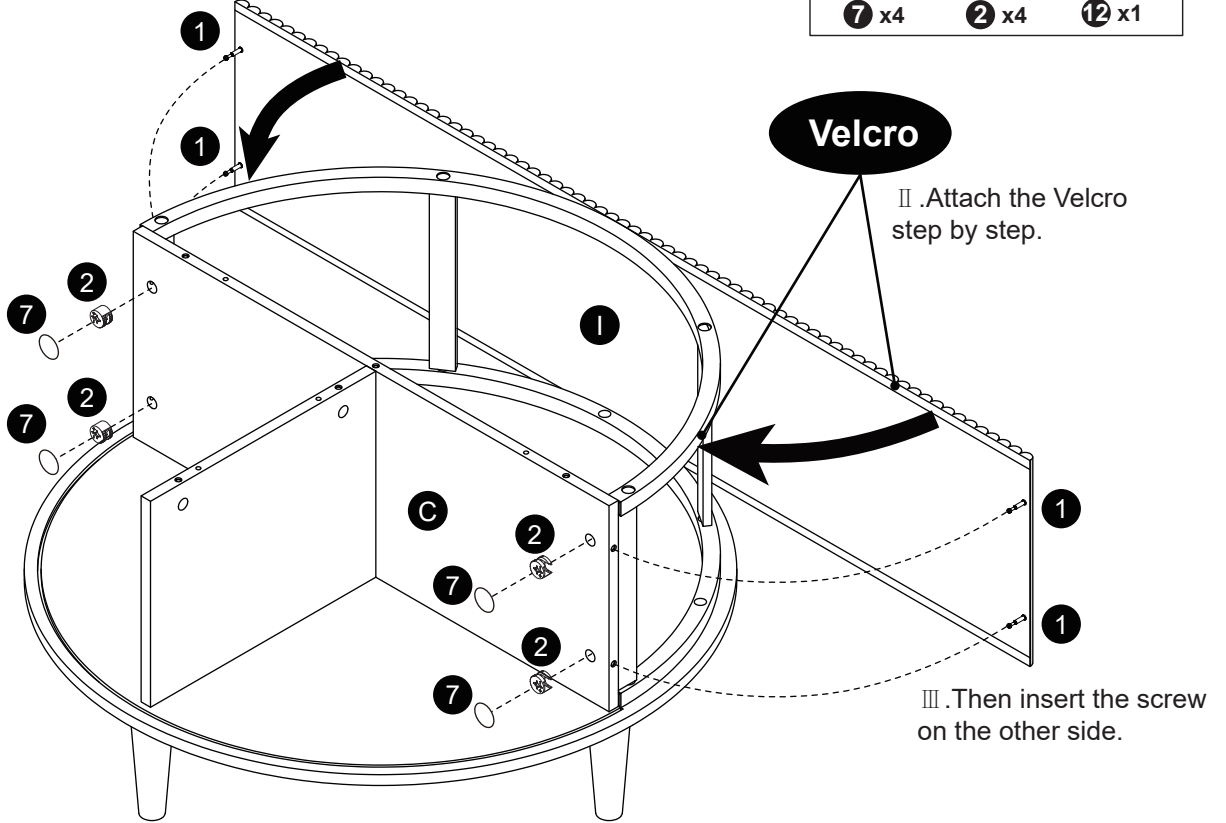
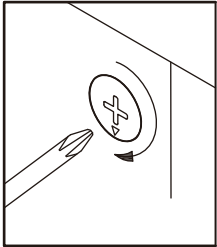
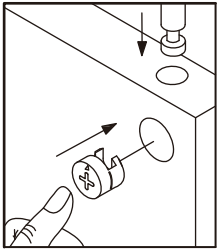

# Step 10

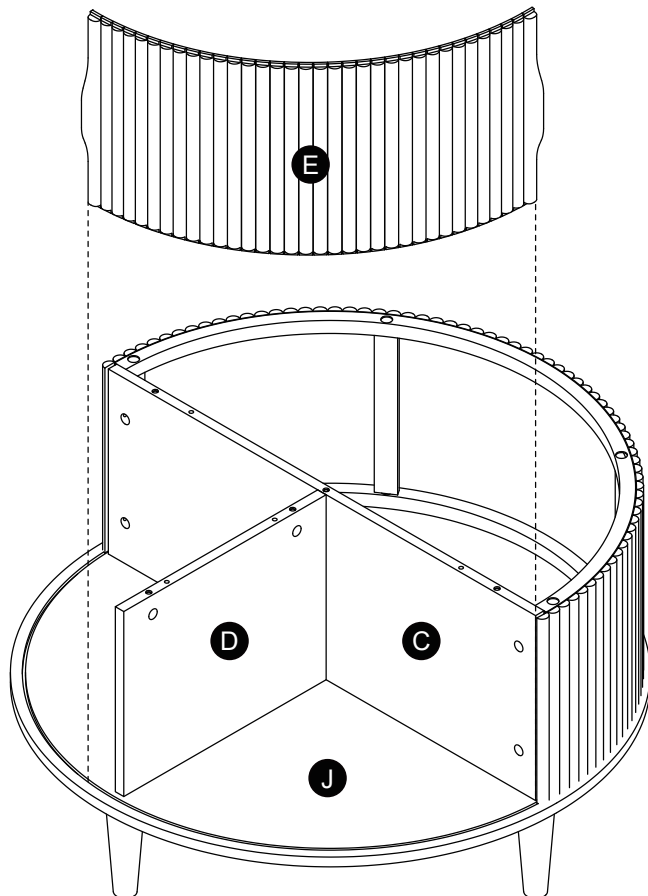

# Step 11

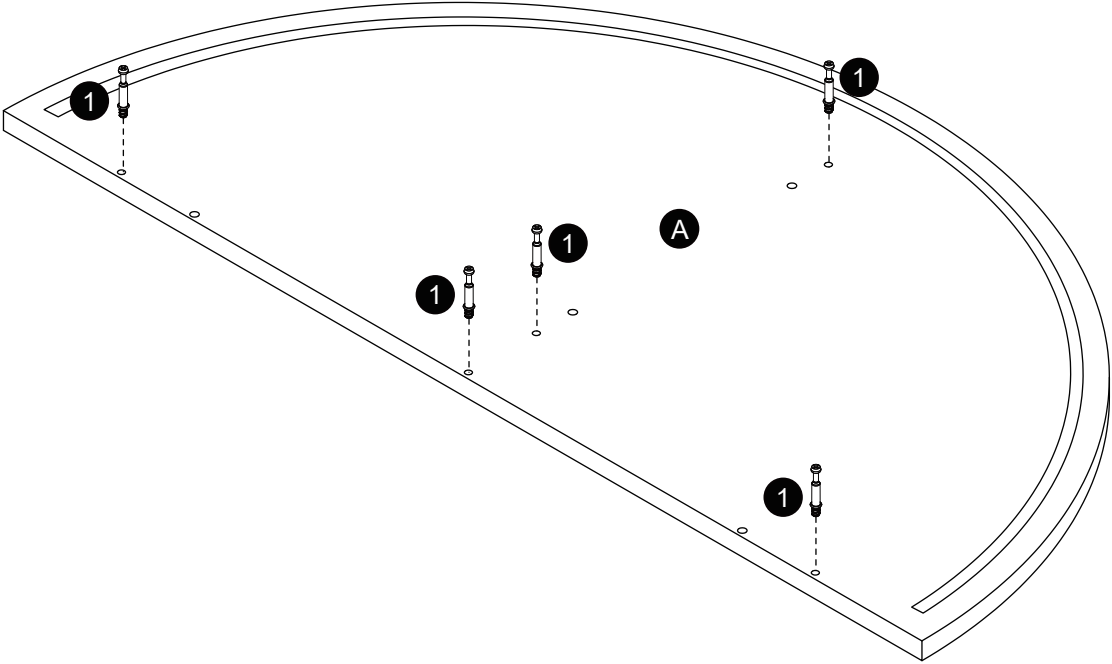
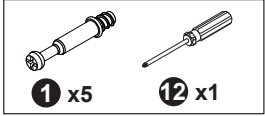

# Step 12

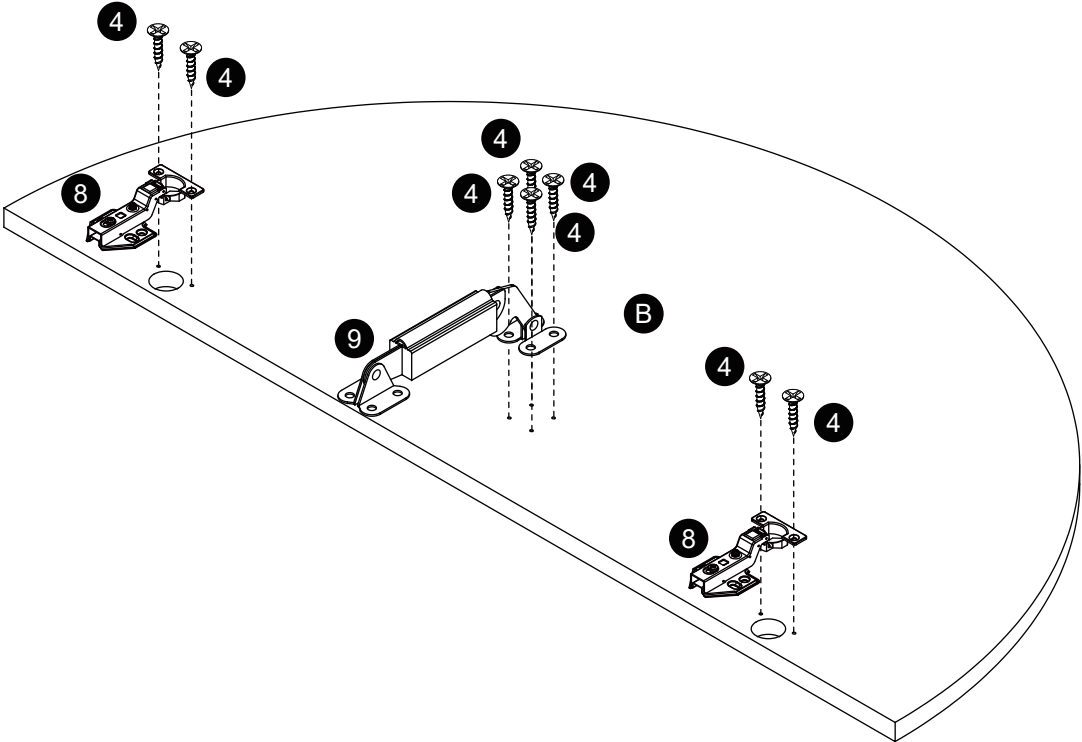
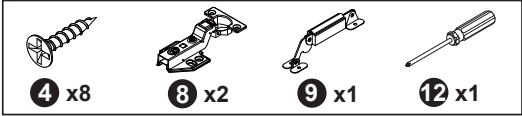

# Step 13

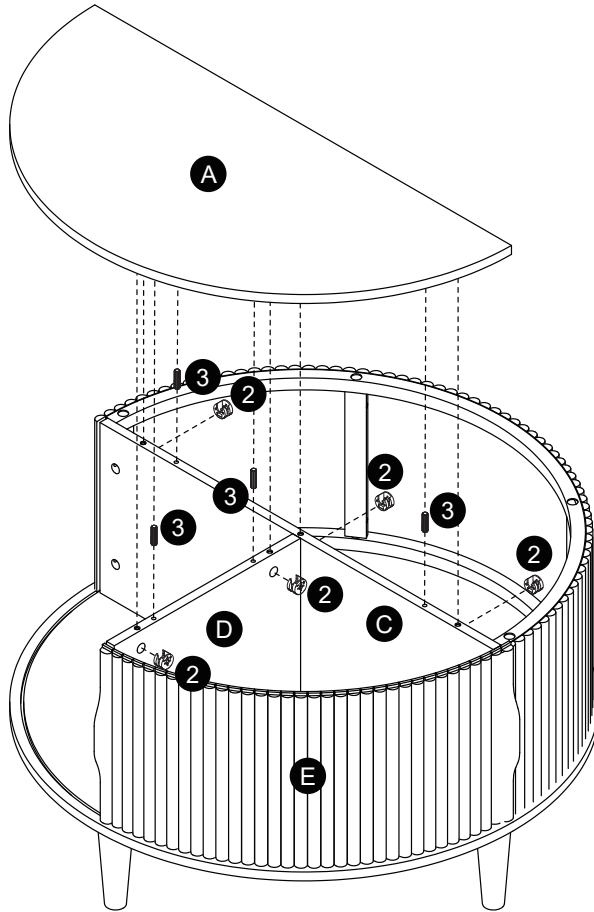

# Step 14

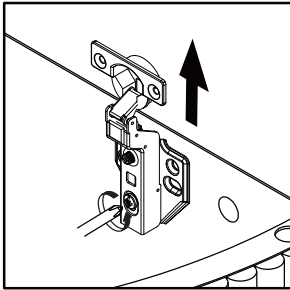

Use the lower screw to adjust the gap between board **B** & **C**.

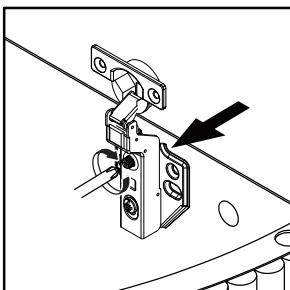

Use the upper screw to adjust the gap between board **A** & **B**.

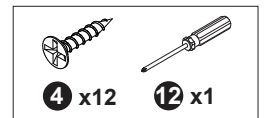
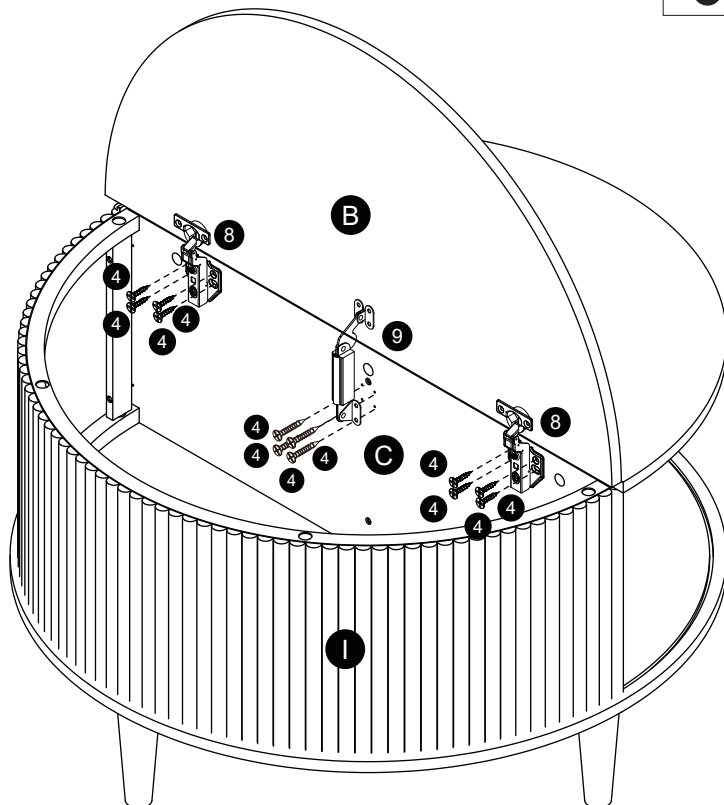

# Step 15

---

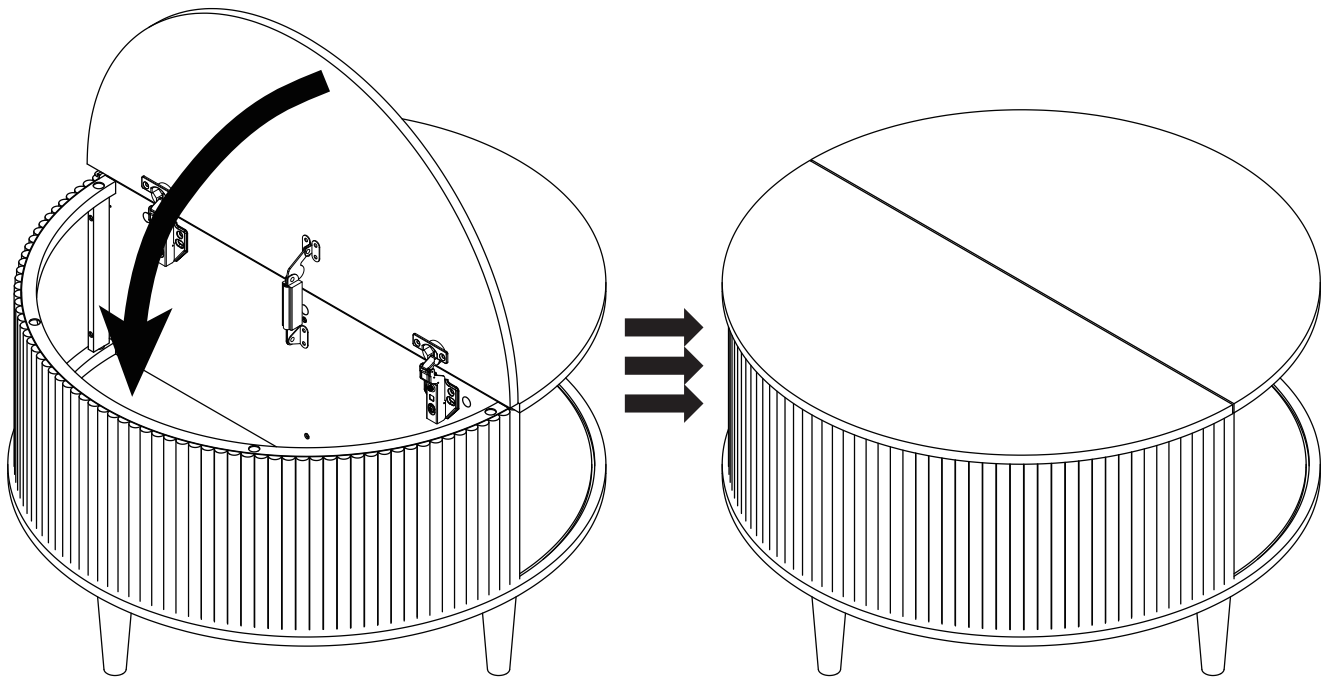

# Step 16

---

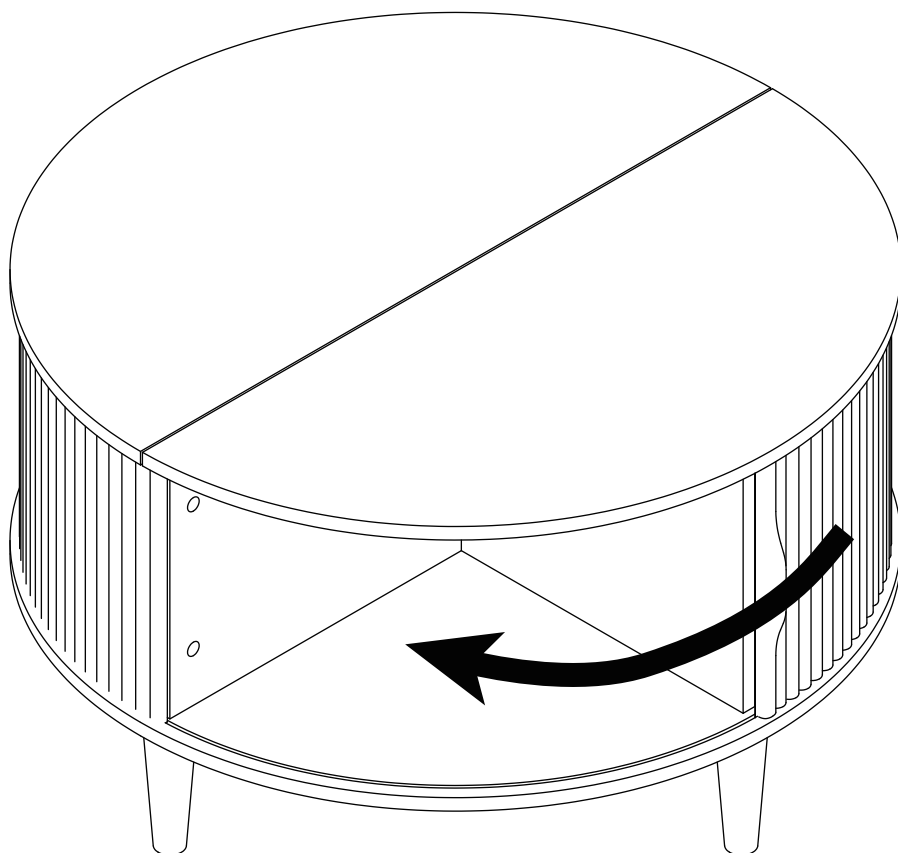

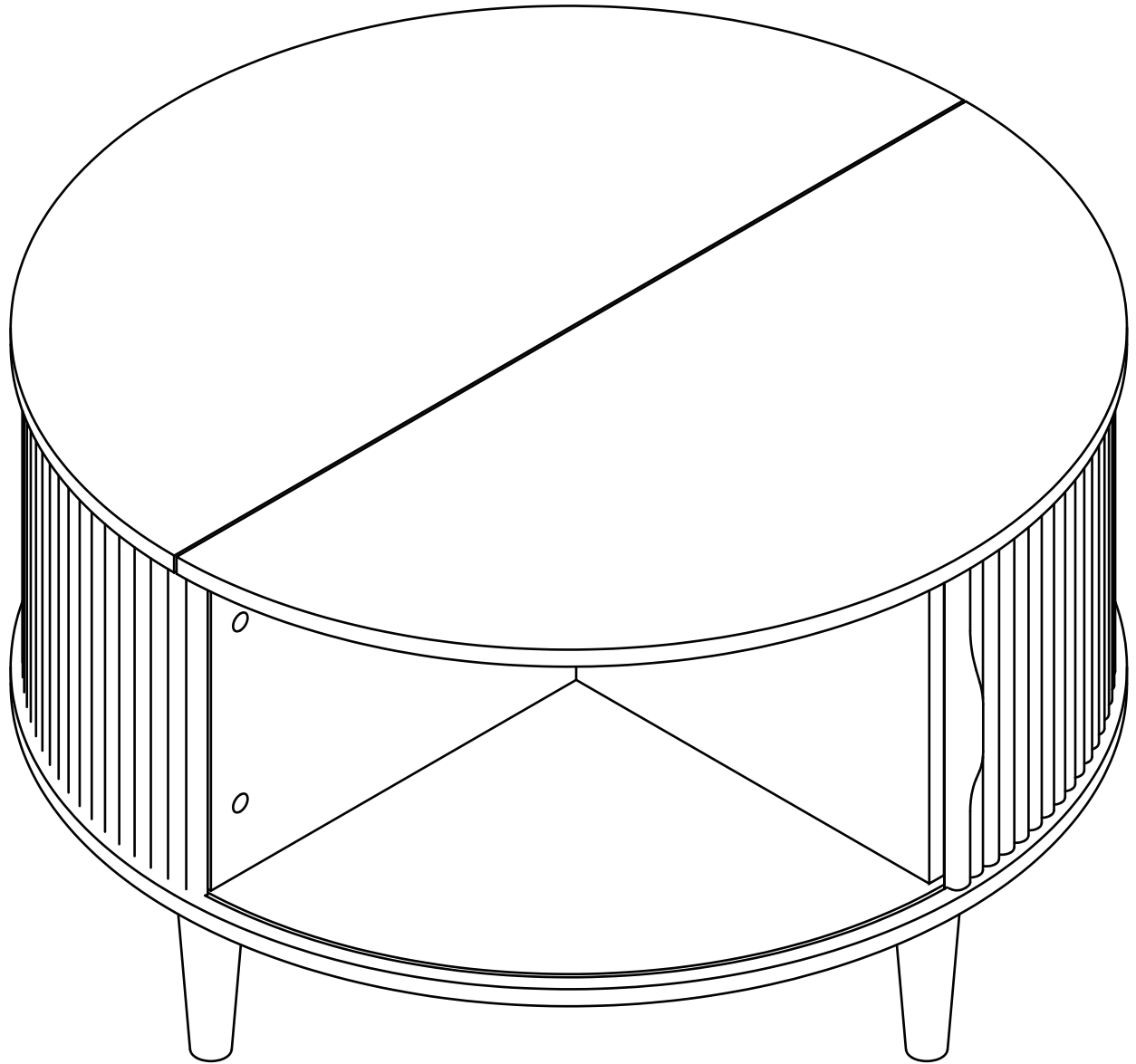

Thank you for choosing this product. We strive to provide you with the best quality products and service in the industry. Should you have any issues, please don't hesitate to contact us.