

Side table

Assembly Instruction - Please keep properly for future reference.

If you find any missing boxes, damaged parts, or accessory shortages, please contact the customer service team of your purchasing channel immediately. We will resolve the issue as quickly as possible.

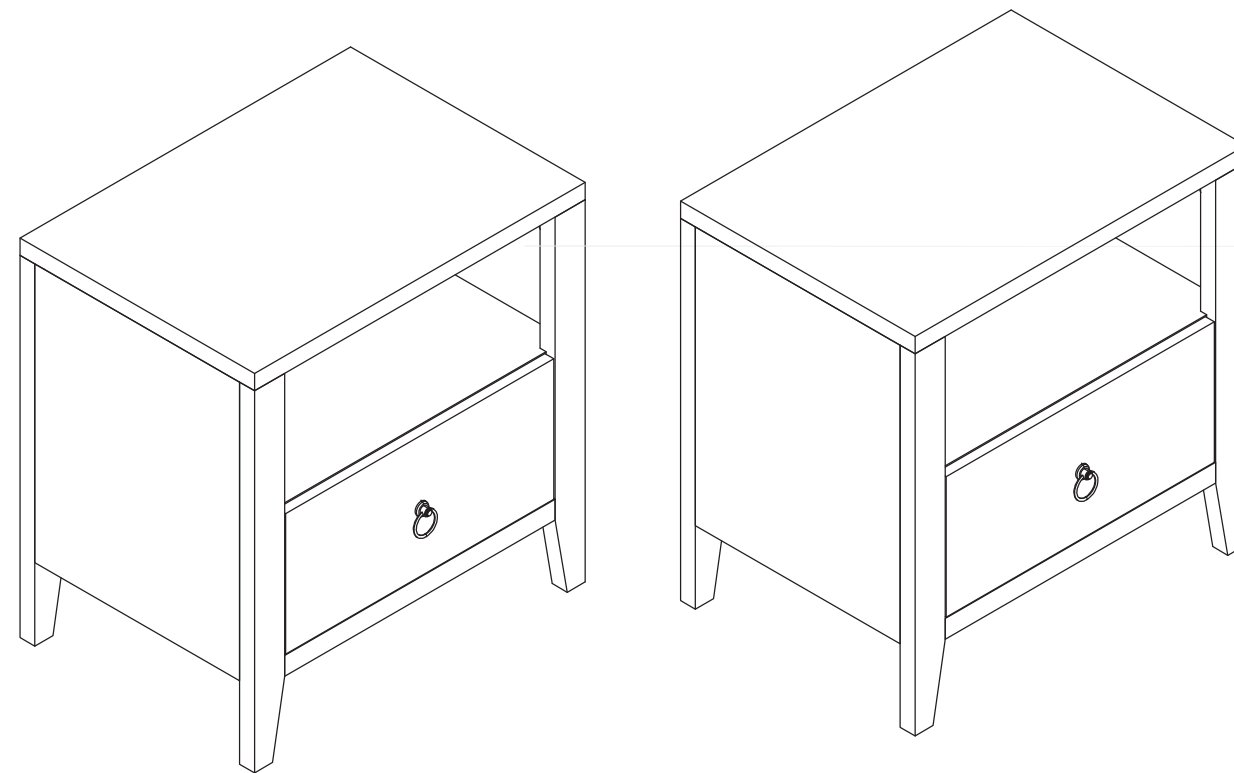

THE FOLLOWING INFORMATION:

- Order number
- Purchase platform
- Purchase date
- Detailed description of the issue along with photos (if applicable)

Important – Please read these instructions carefully before starting the installation.

EN

Before Assembly



Thank you for choosing our product!

To ensure a smooth installation process, please read this guide carefully to familiarize yourself with the required tools, materials, and installation steps. Follow the relevant sections to avoid any damage caused by improper installation, and make sure to review all operation and safety guidelines for correct installation procedures.

Packaging Notice:

If you find any missing boxes, damaged parts, or accessory shortages, please contact the customer service team of your purchasing channel immediately. We will resolve the issue as quickly as possible.

Safety and Care Advice



Important :

Please read these instructions fully before starting assembly.

- Check you have all the components and tools listed on the following pages.
- Remove all fittings from the plastic bags and separate them into their groups.
- Keep children and animals away from the work area, small parts could choke if swallowed.
- Make sure you have enough space to layout the parts before starting.
- During assembly do not stand or put weight on the product, this could cause damage.
- Assemble the item as close to its final position (in the same room) as possible.
- Assemble on a soft level surface to avoid damaging the unit or your floor.
- Parts of the assembly will be easier with 2 people.



- To reduce the likelihood of damaging your product please ensure that your power drill is set on a low torque setting.

Care and maintenance

- Only clean using a damp cloth and mild detergent, do not use bleach or abrasive cleaners.
- From time to time check that there are no loose screws on this unit.
- This product should not be discarded with household waste. Take to your local authority waste disposal center.

Handy Hints

- Assemble all parts and bolts loosely during assembly, only once the product is complete should you fully tighten the bolts.
- Regularly check and ensure that all bolts and fittings are tightened properly.

Warning

In order to help prevent overturning, please follow these instructions.

- Use the anti tip strap or wall fixing method provided (if applicable).
- Do not allow children to climb or hang on the furniture.
- Do not open more than one drawer at a time.
- Do not place heavy items in the top drawers.
- Do not place heavy items on top of the furniture, unless the furniture has been designed for this purpose.
- Please note that only the anti tip strap is provided. You will need to provide wall plugs and screws applicable for your wall type.

Customer Service Guide



Thank you for choosing our product! We are committed to providing you with excellent service. If you find any missing parts, damaged packaging, or product damage after receiving all packages, please follow the steps below to quickly contact our customer service team. We will do our best to resolve your issue.

1. Missing Parts

Verify Parts:

1. Refer to the “Parts List” in the manual to verify the name, specifications, and quantity of the missing parts.
2. Take a clear photo of the parts list and mark the missing parts with detailed information, e.g., “Missing 5 pieces of M6×30mm screws.”

Contact Us:

By Email:

Send an email with the subject line ‘Missing Parts Issue.’ Include the following in the email:

- A description of the missing parts and a photo of the parts list.
- Order details (order number, purchase platform, purchase date).

2. Product or Packaging Damage

If it affects normal use:

Steps:

1. Take clear photos or videos showing the damaged parts and the extent of the damage (multi-angle shots are recommended).
2. Email the photos/videos along with order details to [redacted] with the subject line “Product Damage Issue.”

Resolution:

After verification, we will arrange for a replacement part, product exchange, or refund as quickly as possible.

If it does not affect normal use:

Steps:

1. Contact our customer service team [redacted]
2. Provide a description of the damage and include relevant photos or videos.

Resolution:

We will provide repair guidance or an appropriate compensation plan based on the specific situation.

Helpful Tips

To process your issue efficiently, please prepare the following information:

- Order details (order number, purchase platform, purchase date).
- Clear photos or videos.
- We are committed to providing quick and professional solutions, no matter the size of the issue, to ensure your satisfaction.

Thank you for your trust and support!
We hope you enjoy using our product!

Parts List

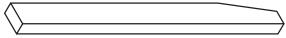
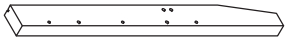
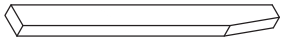
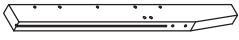
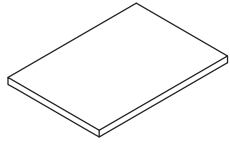
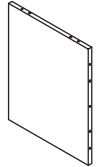
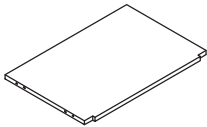
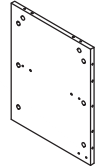
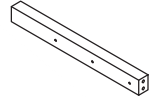
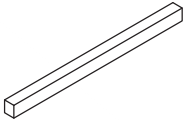
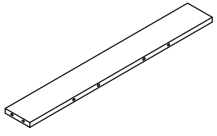
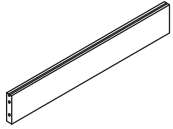

Please check you have all the panels listed below.

		
1 550x50x25mm x2	2 550x50x25mm x2	3 550x50x25mm x2
		
4 550x50x25mm x2	5 550x390x25mm x2	6 430x340x12mm x2
		
7 524x347x12mm x2	8 430x340x12mm x2	9 340x35x25mm x4
		
10 450x30x25mm x2	11 525x70x12mm x2	12 450x70x15mm x2

Parts List



Please check you have all the panels listed below.

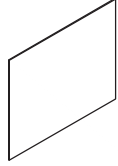
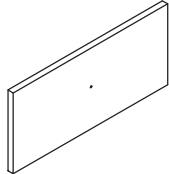
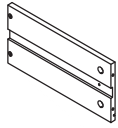
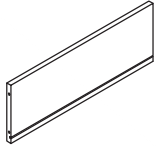
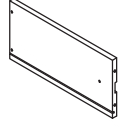
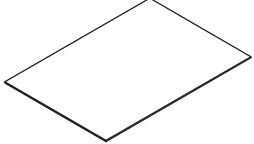



		
13 457x368x3mm x2	14 442x195x15mm x2	15 297x145x12mm x2
		
16 410x145x12mm x2	17 297x145x12mm x2	18 417x292x3mm x2

Parts List - Fittings

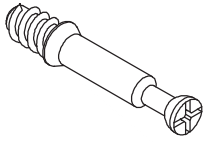
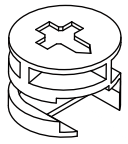
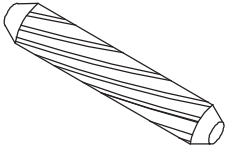
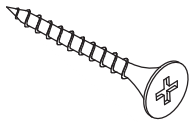

Please check you have all the fittings listed below.

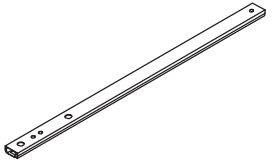
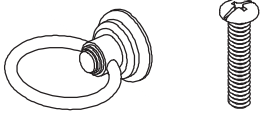
Note: The quantities below are the correct amount to complete the assembly. In some cases more fittings may be supplied are required.

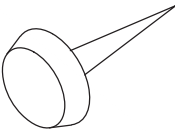
		
A x68	B x68	C \varnothing 6x30mm x52
		
D \varnothing 4x35mm x8	E \varnothing 3x12mm x12	F x4
		
G \varnothing 4x16mm x2	H \varnothing 4x10mm x4	J \varnothing 3x14mm x8
		
K x8		

Tools required

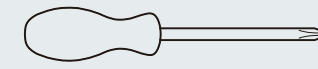

Phillips screwdriver
(medium & large)

Ruler

Use this ruler to help correctly identify the screws

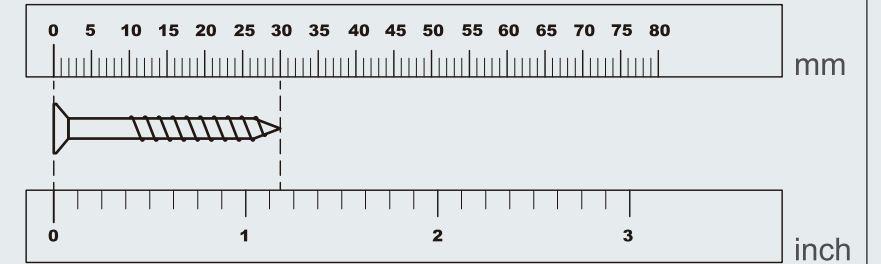

The screws length is measured from the head to the point (30mm screw shown).



Using Camlocks

Step 1

Connect the male camlock as directed in the assembly instructions using a screwdriver.

1

DO NOT OVER TIGHTEN.
NE PAS SERRER EXCESSIVEMENT.

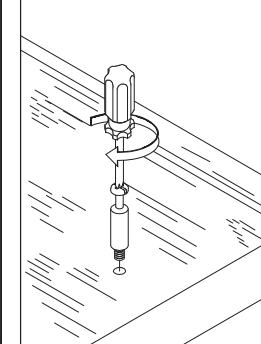

Step 2

Push the male camlock into the entry hole.

2

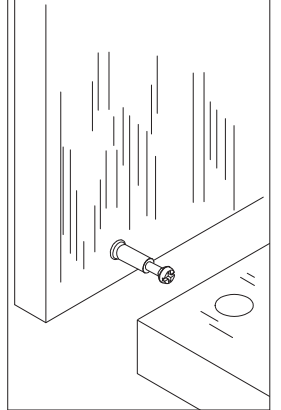

Step 3

Insert the female camlock as shown in the instruction.

Note: ensure that the arrow on the top of the camlock points towards the entry hole for the male camlock.

3

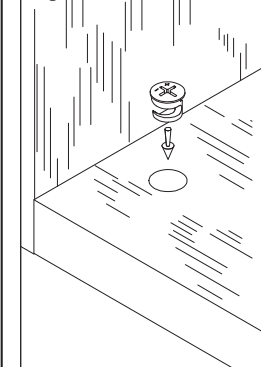

Step 4

Turn the female camlock clockwise with a screwdriver.

You should feel a click when the camlock is locked in place.

The joint is now secure.

4

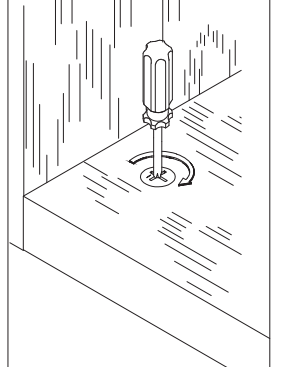

Assembly Instructions



X2

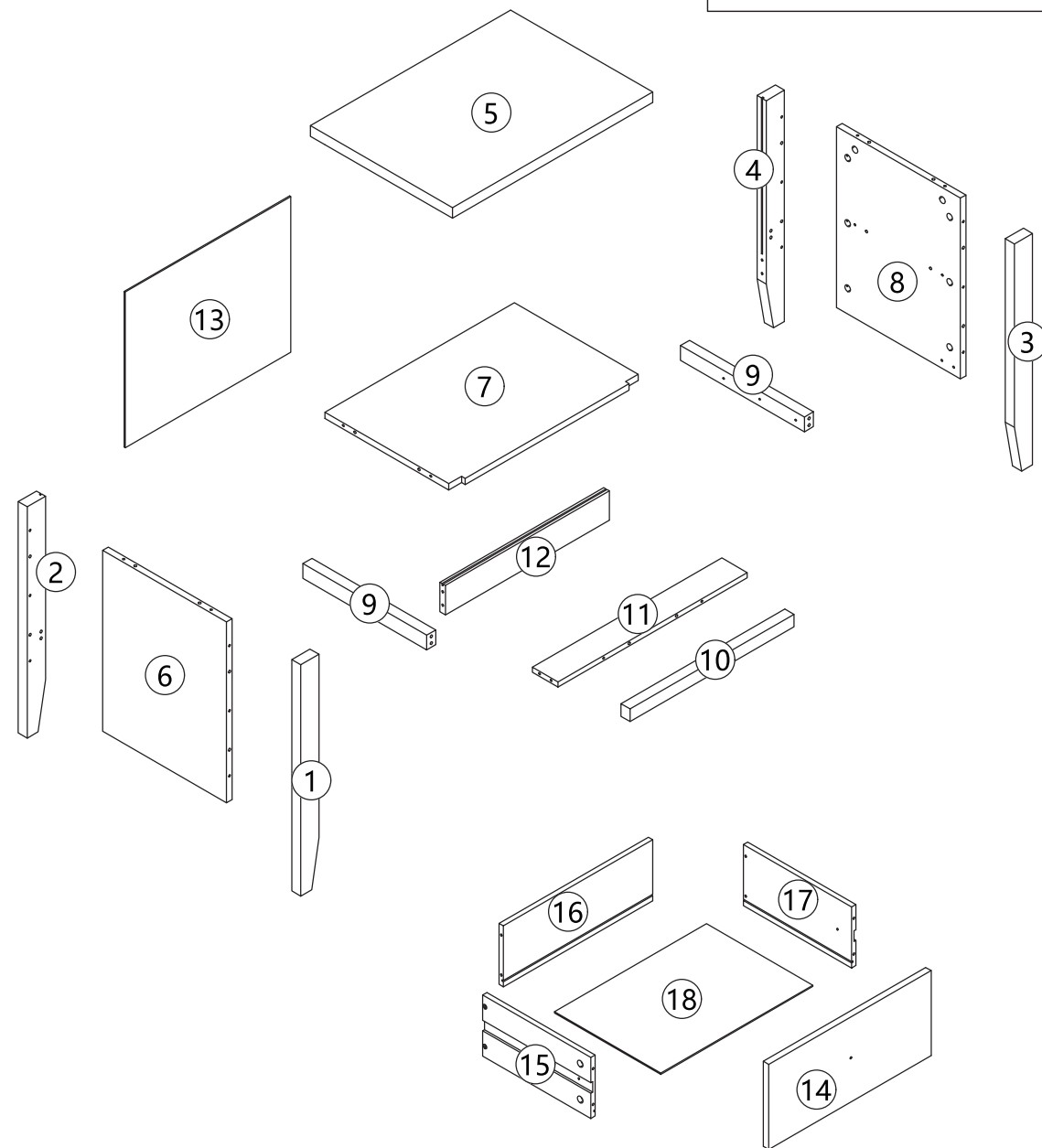
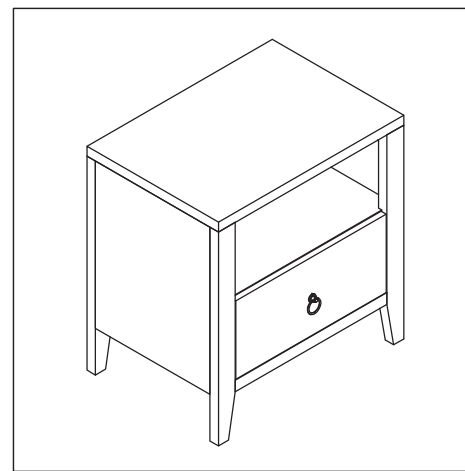

Step 1

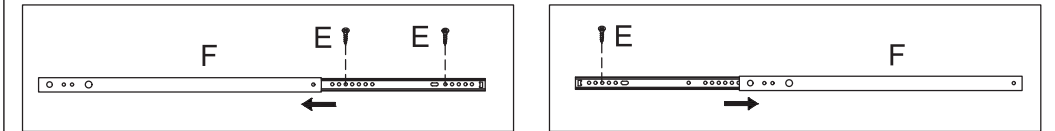
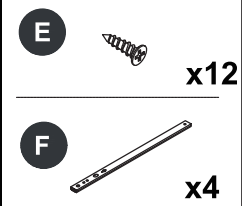

X4

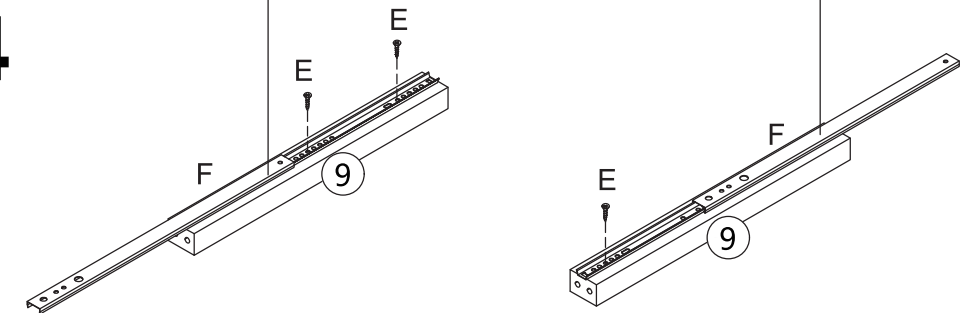

Place rail (F) onto part (9) and secure it with screws (E). Repeat this procedure for two additional sets.

Step 2

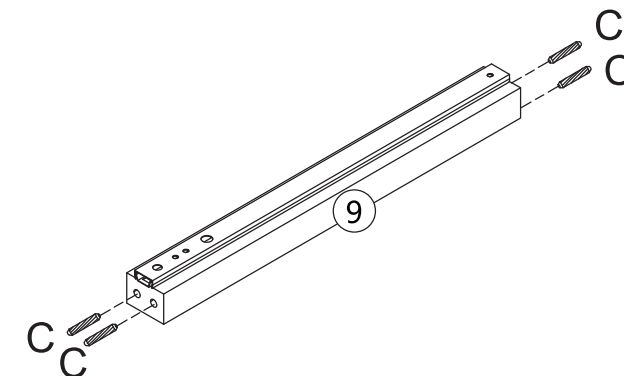

X4

Insert dowels (C) into the holes at both ends of part (9). Repeat the same procedure for two additional sets.

Step 3

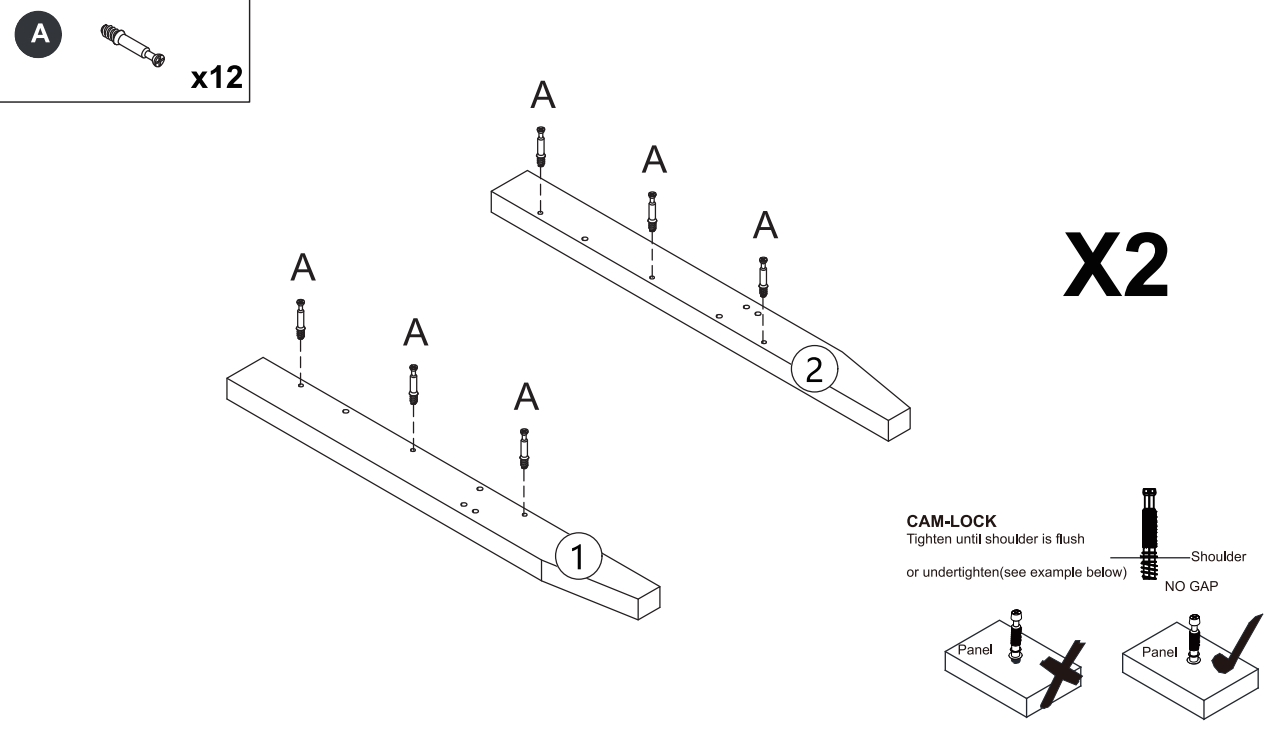

Screw hardware (A) into the holes of parts (1) and (2).

Step 4

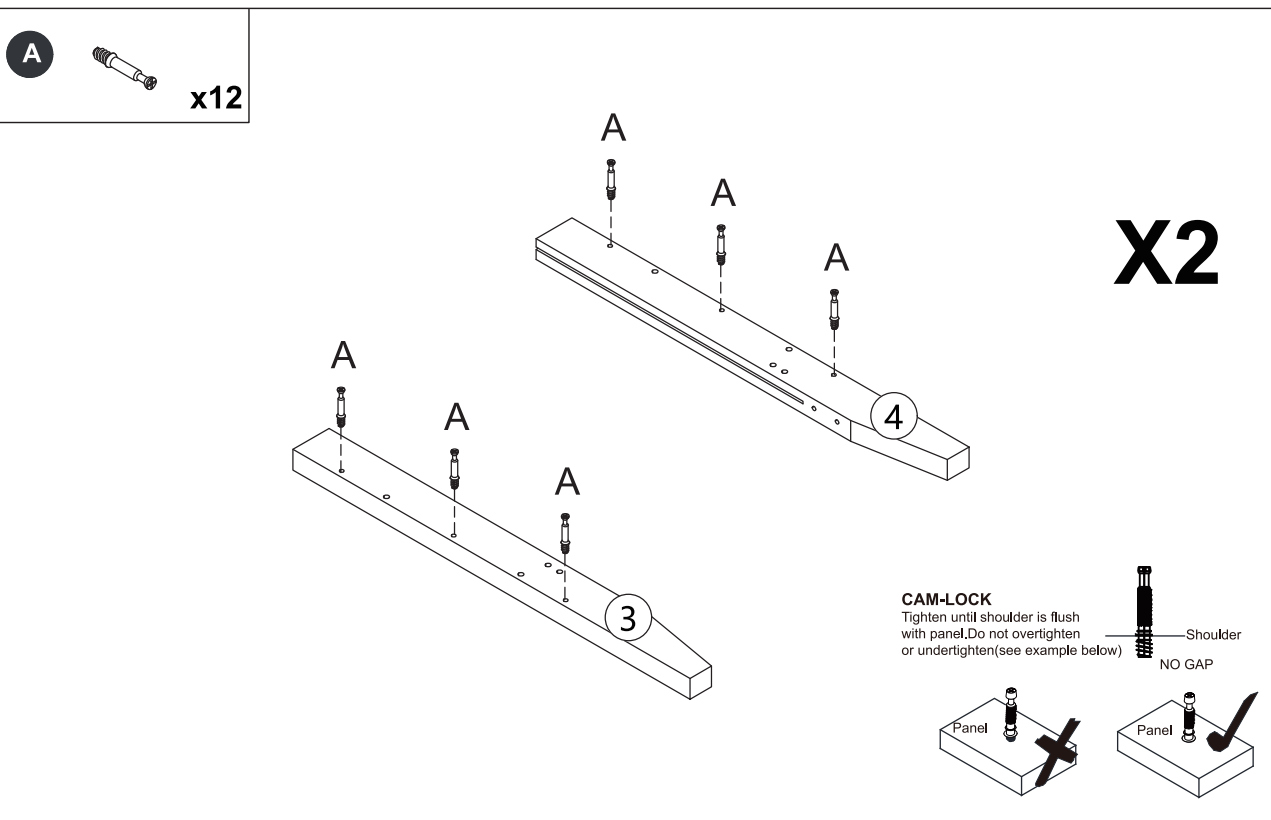

Screw hardware (A) into the holes of parts (3) and (4).

Step 5

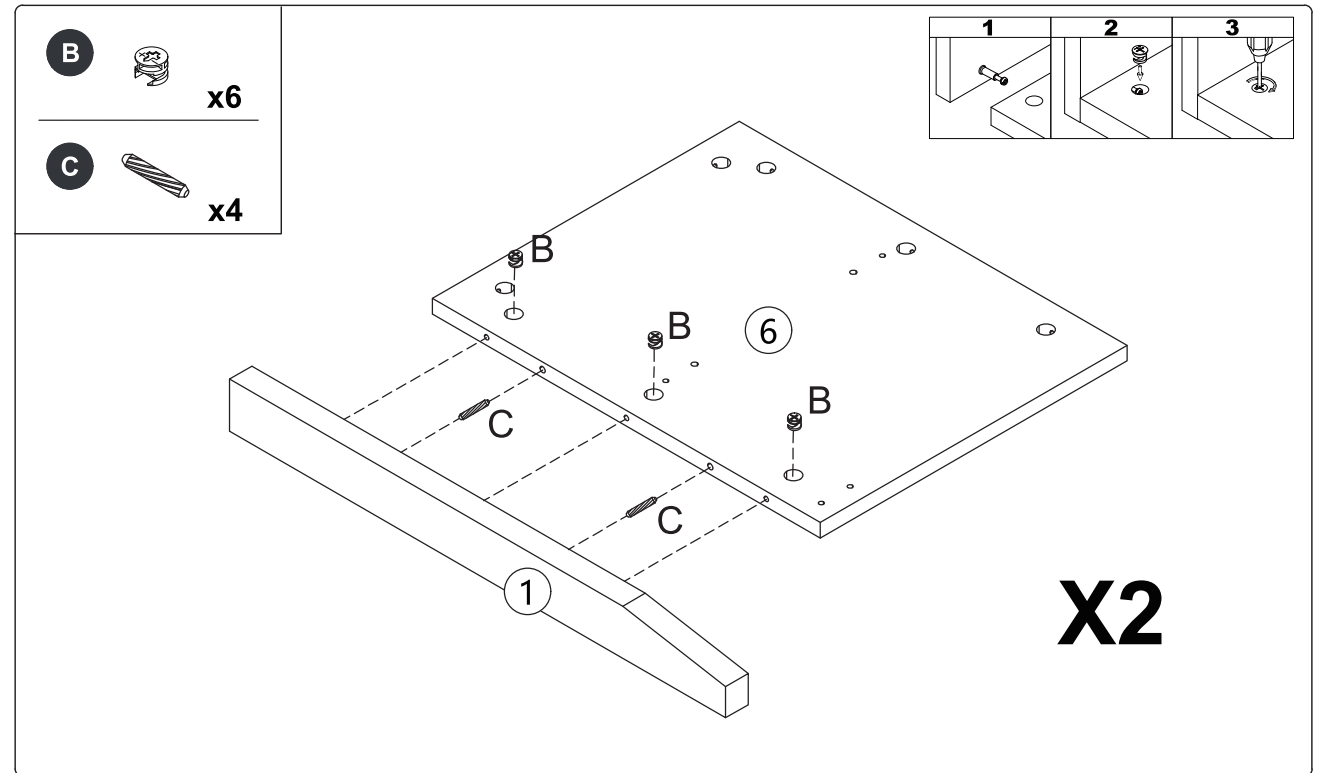

Connect parts (1) and (6) using dowels (C) and secure them with hardware (B).

Step 6

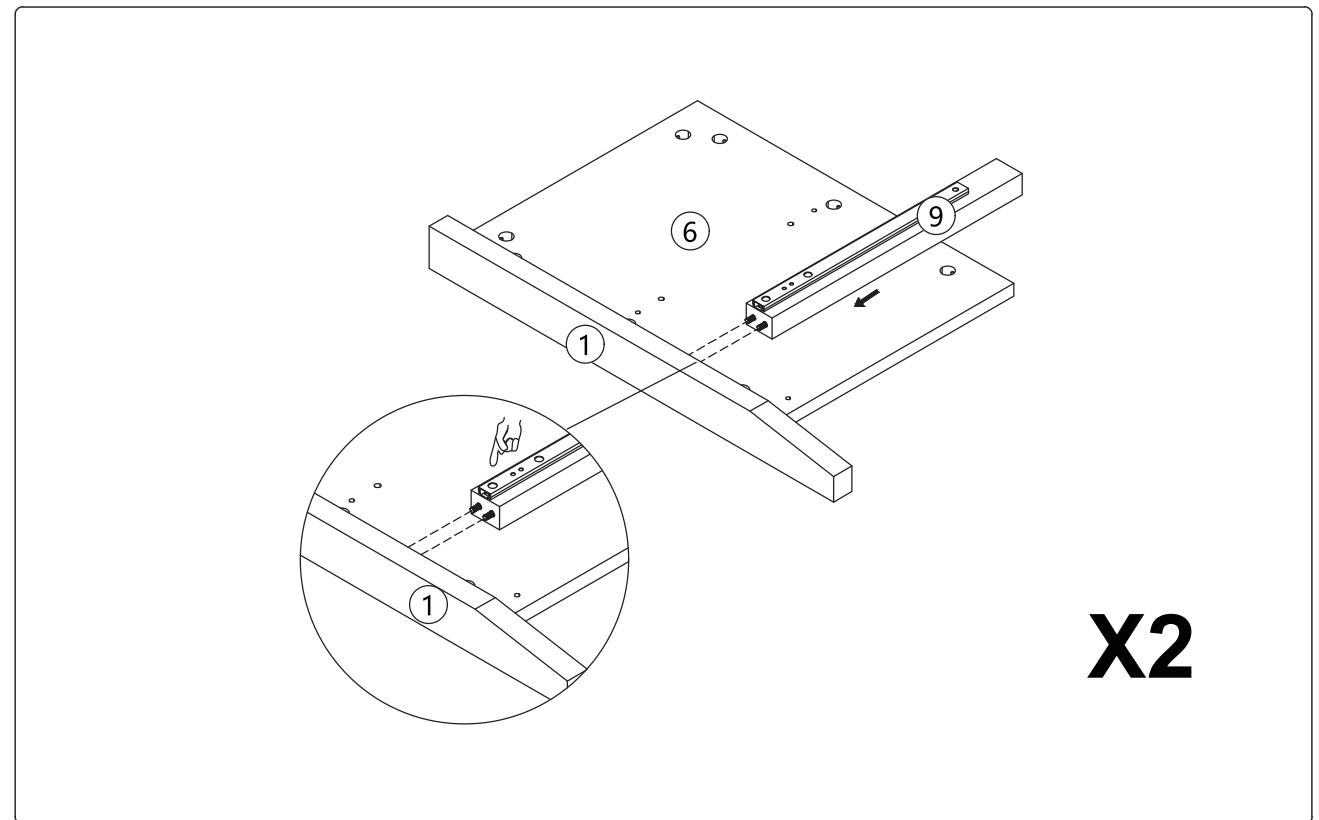

On part (6), connect parts (1) and (9), following the arrow direction and ensuring that the side with more rail holes faces part (1).

Step 7

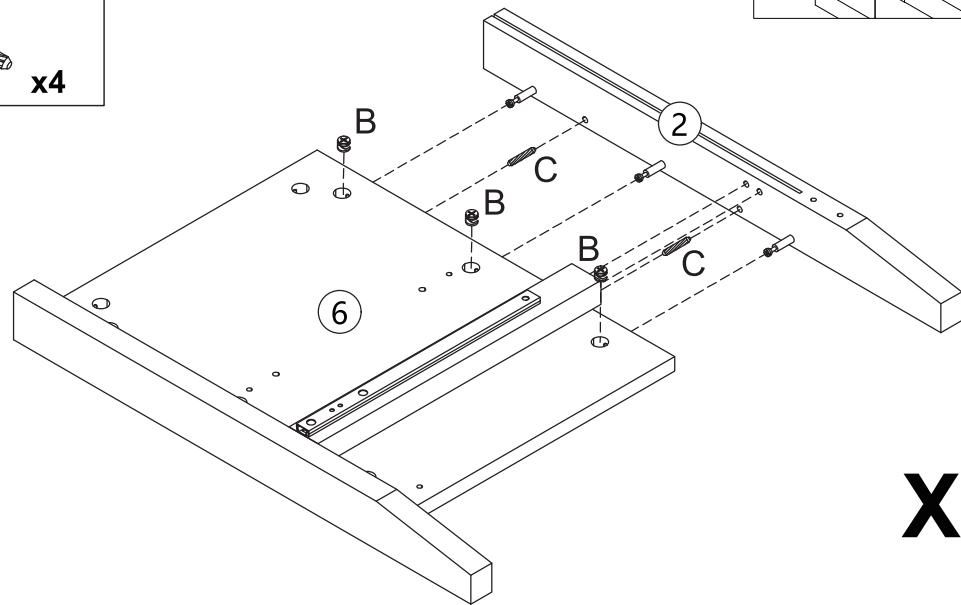
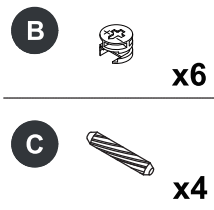

Connect parts (2) and (6) using dowels (C) and secure them with hardware (B).

Step 8

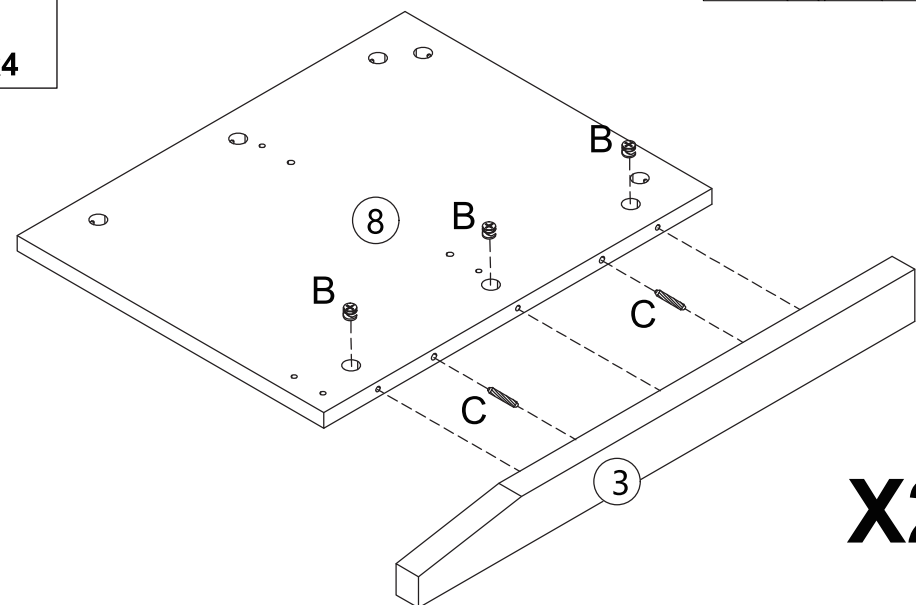
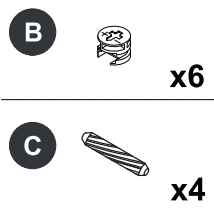

Connect parts (3) and (8) using dowels (C) and secure them with hardware (B).

Step 9

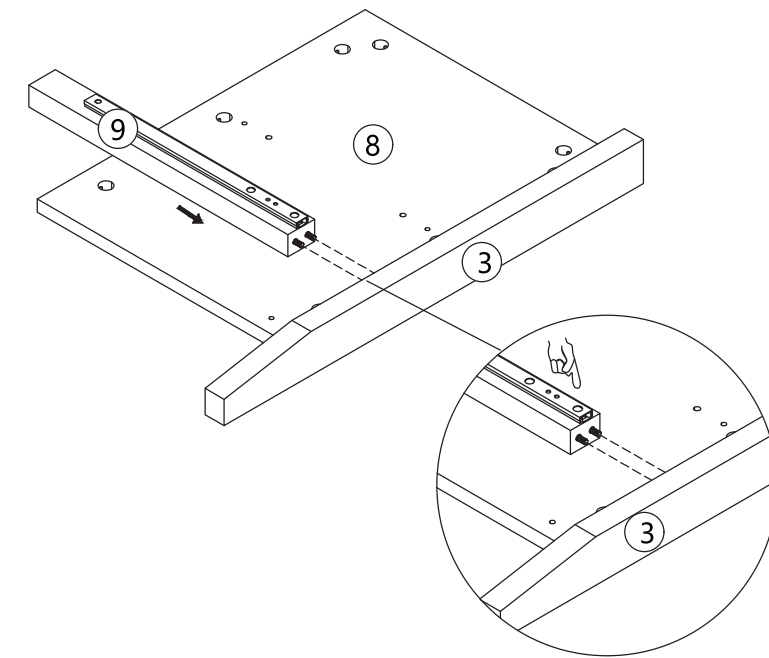

On part (8), connect parts (3) and (9), following the arrow direction and ensuring that the side with more rail holes faces part (3).

Step 10

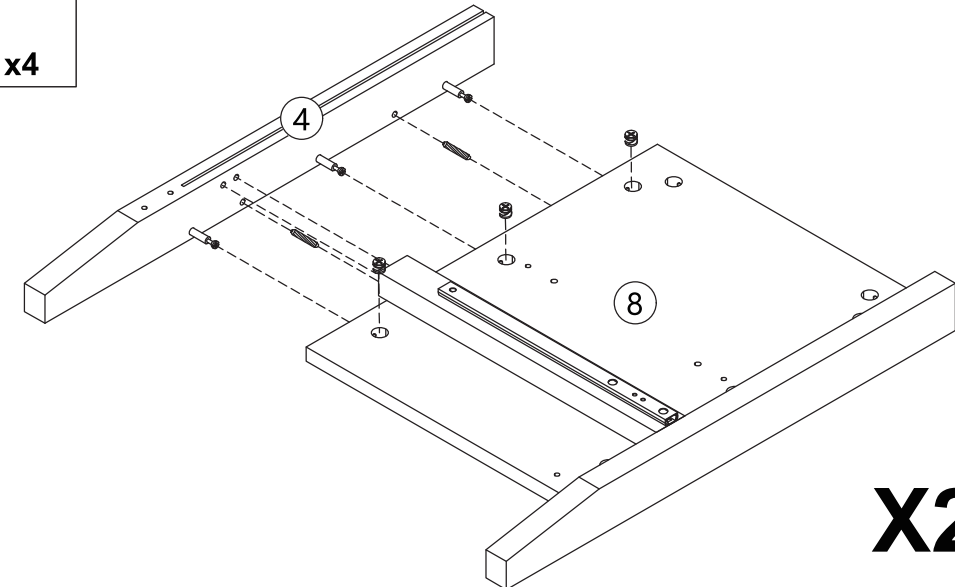
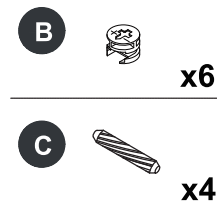

Connect parts (4) and (8) using dowels (C) and secure them with hardware (B).

Step 11

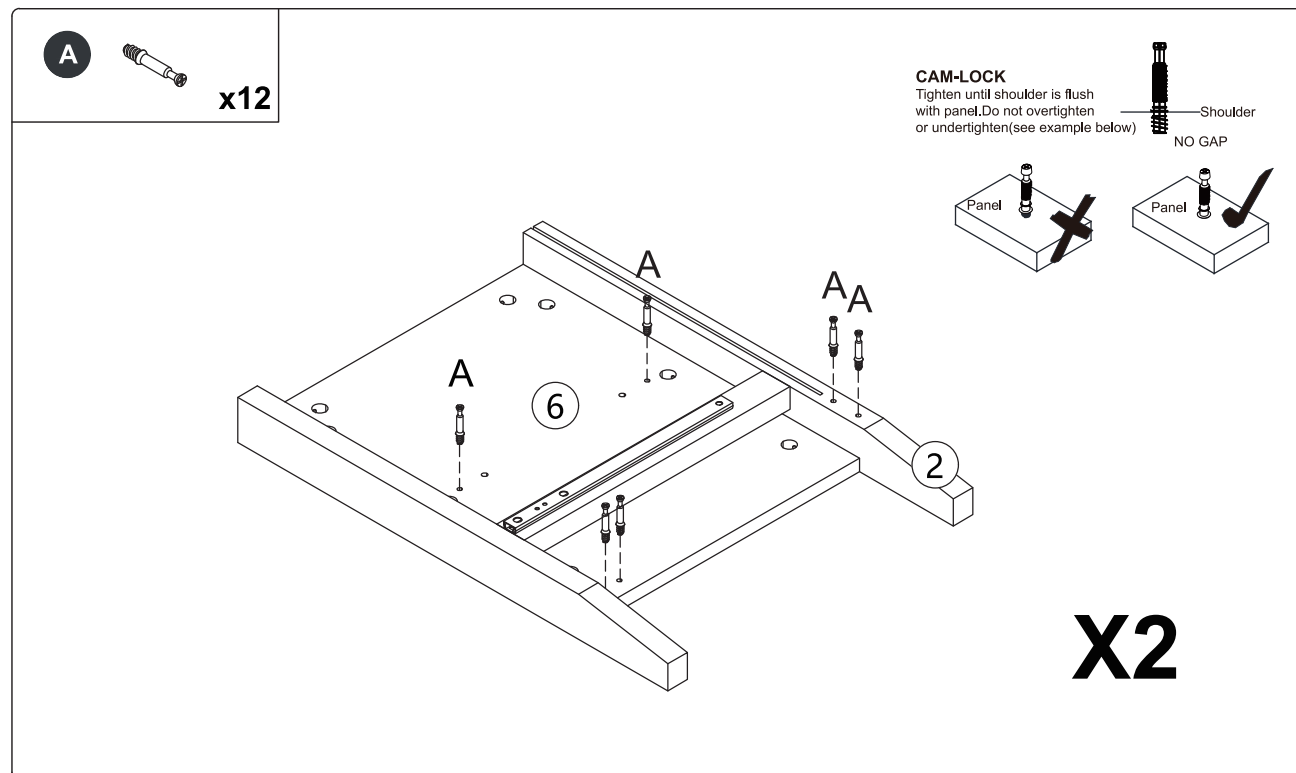

Screw hardware (A) into the holes of parts (2) and (6).

Step 12

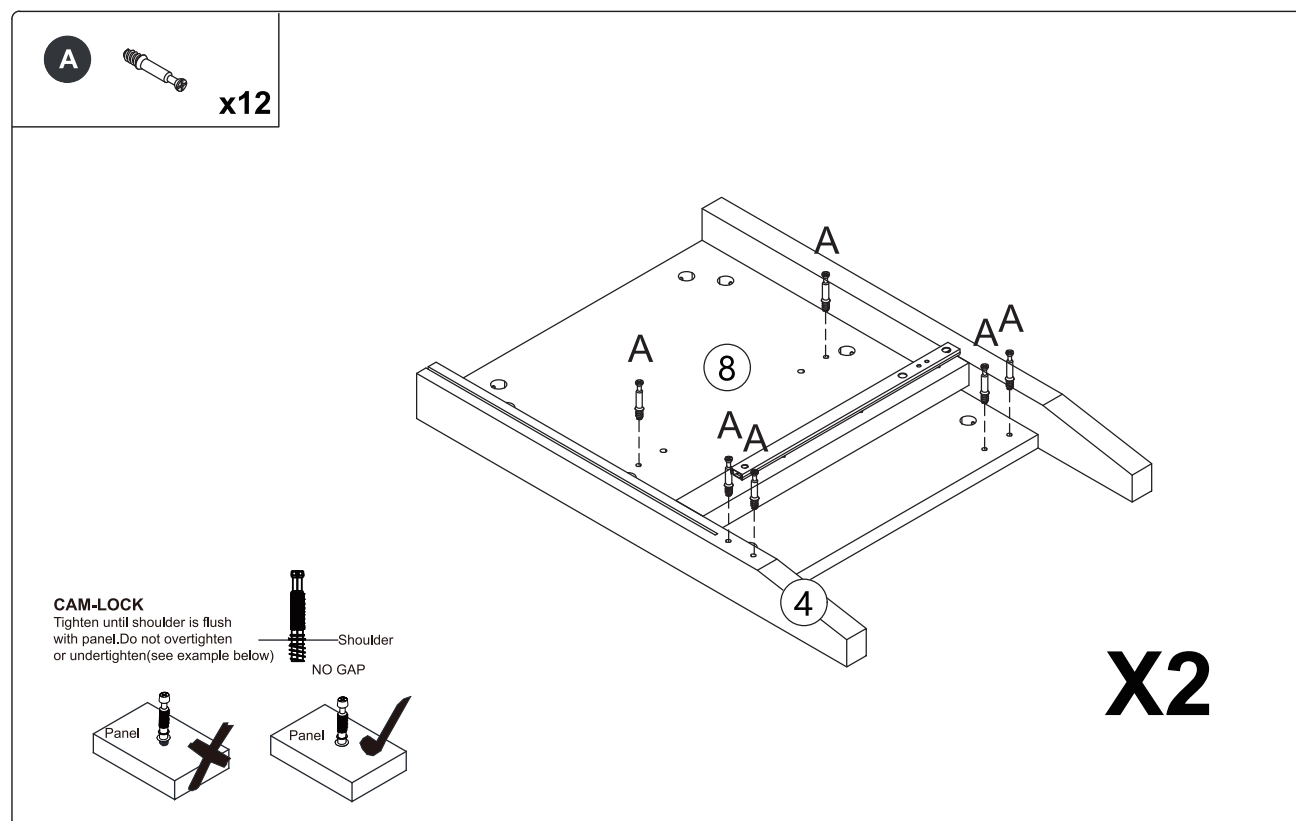

Screw hardware (A) into the holes of parts (4) and (8).

Step 13

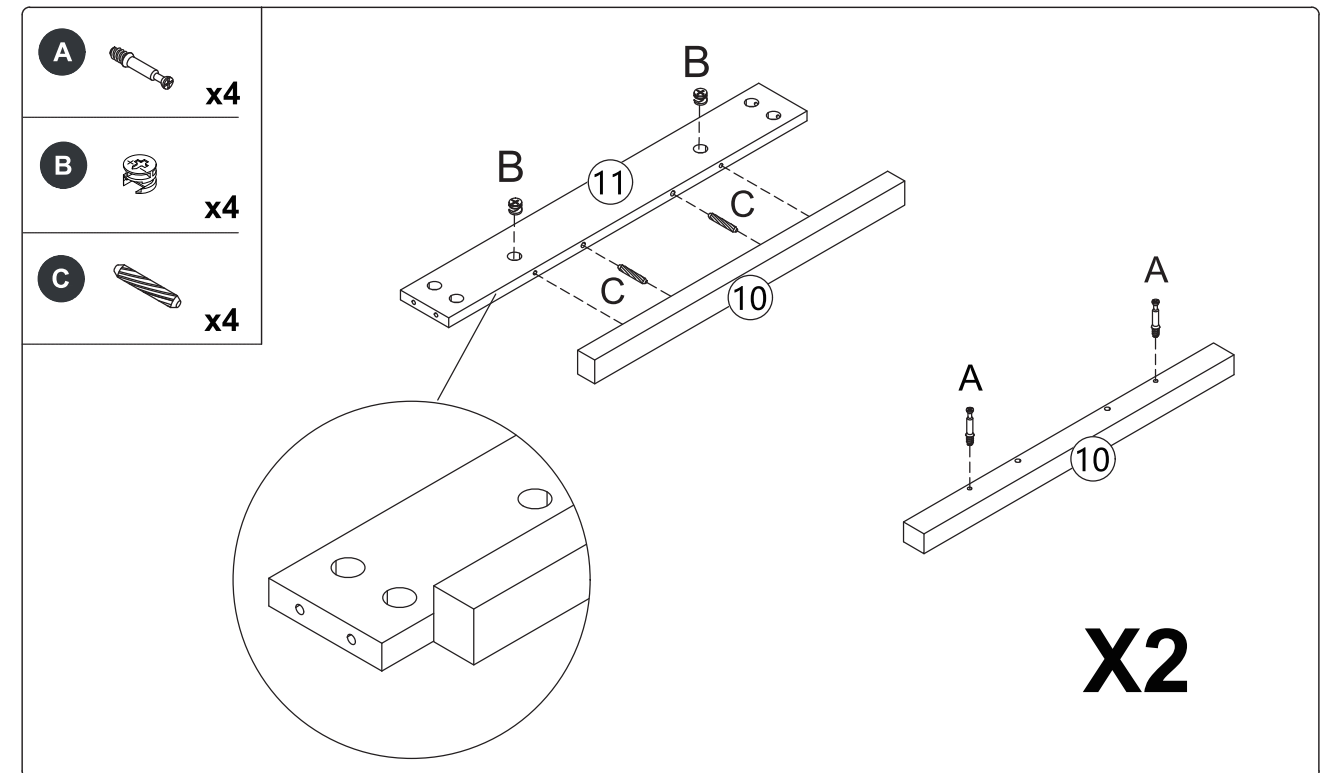

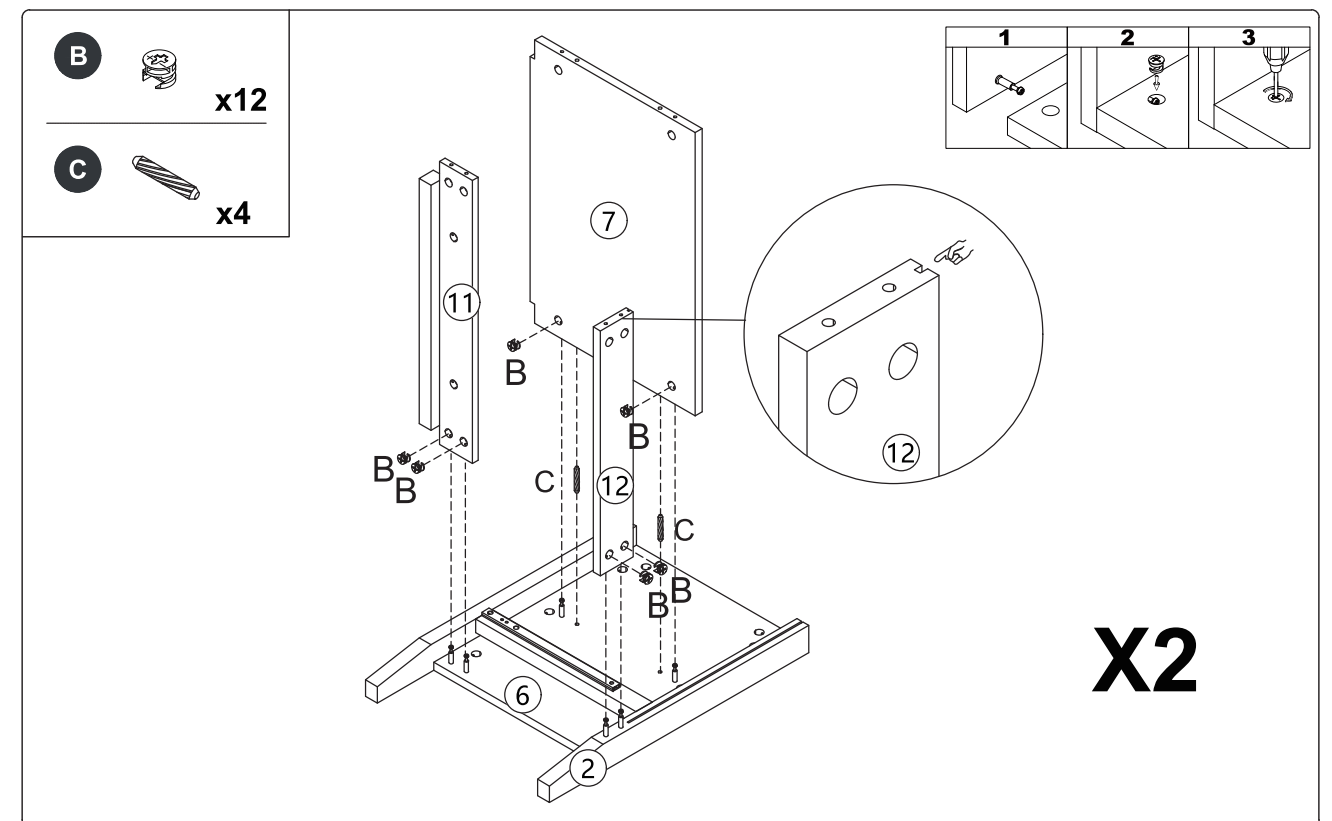

Screw hardware (A) into the holes of part (10). Insert dowels (C) to connect part (11) and part (10), then secure them with hardware (B).

Step 14



1. Insert dowels (C) into part (7) and connect it to part (6).
2. Connect parts (11) and (6), and parts (12) and (2). 3. Secure them with hardware (B).

Step 15

- B**  x12
- C**  x4

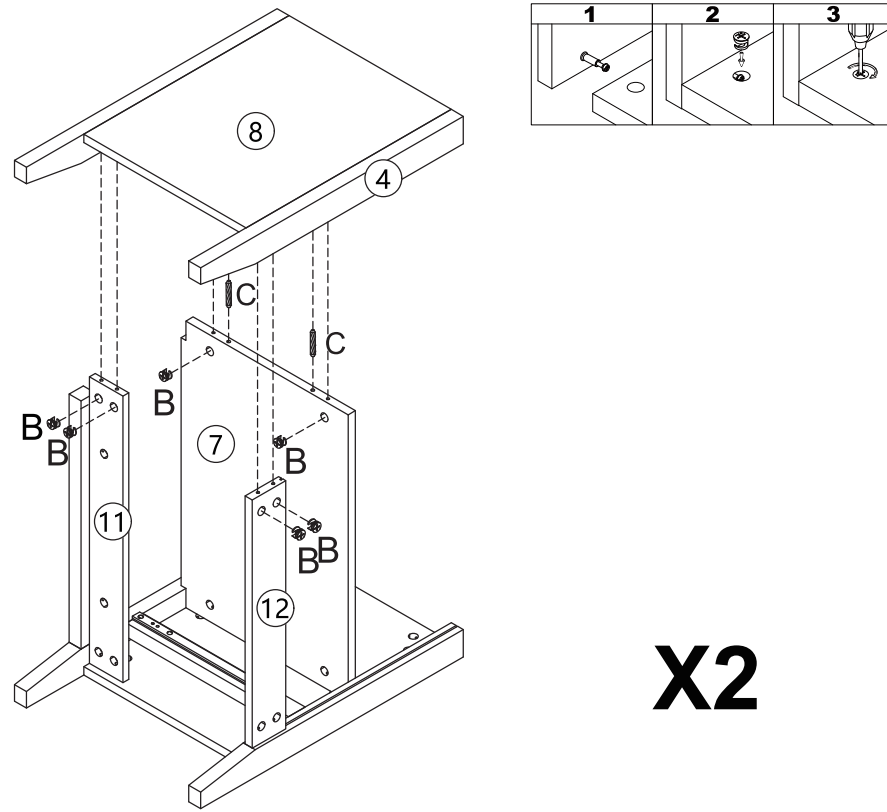

1. Insert dowels (C) into part (7) and connect it to part (8).
2. Connect parts (11) and (8), parts (12) and (4). 3. Secure with hardware (B).

Step 16

- K**  x8

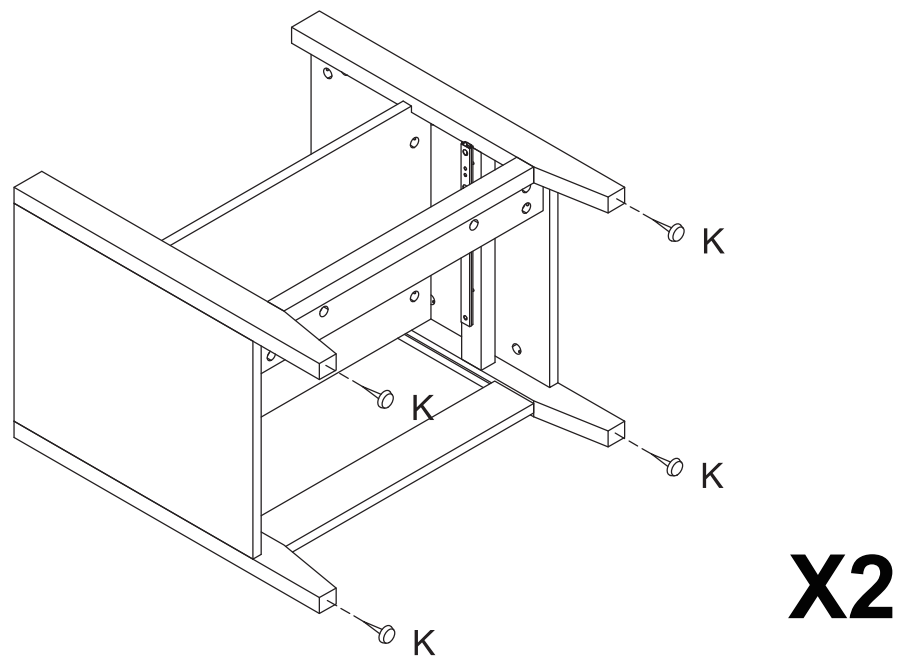

Tap foot pegs (K) into the bottoms of all four legs.

Step 17

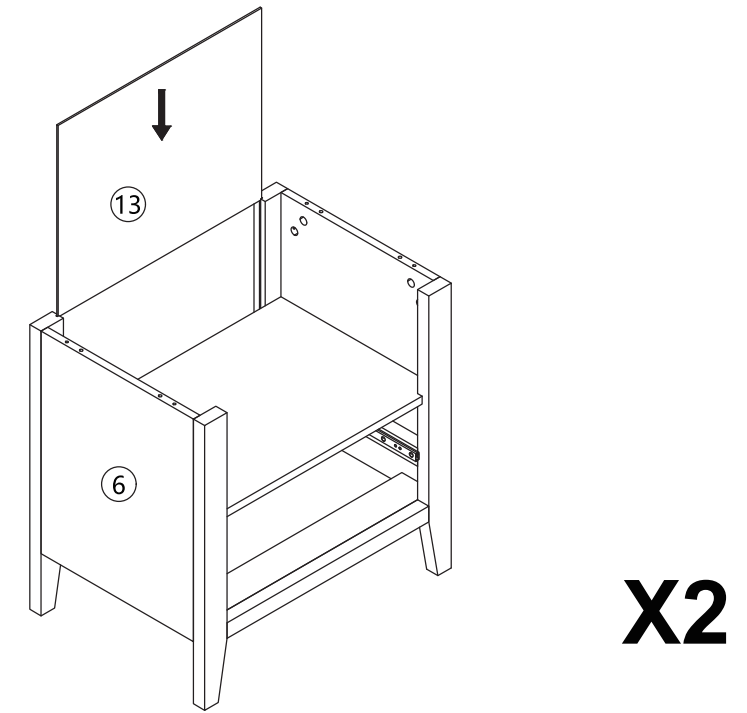

Insert part (13) into the designated slot.

Step 18

- A**  x8

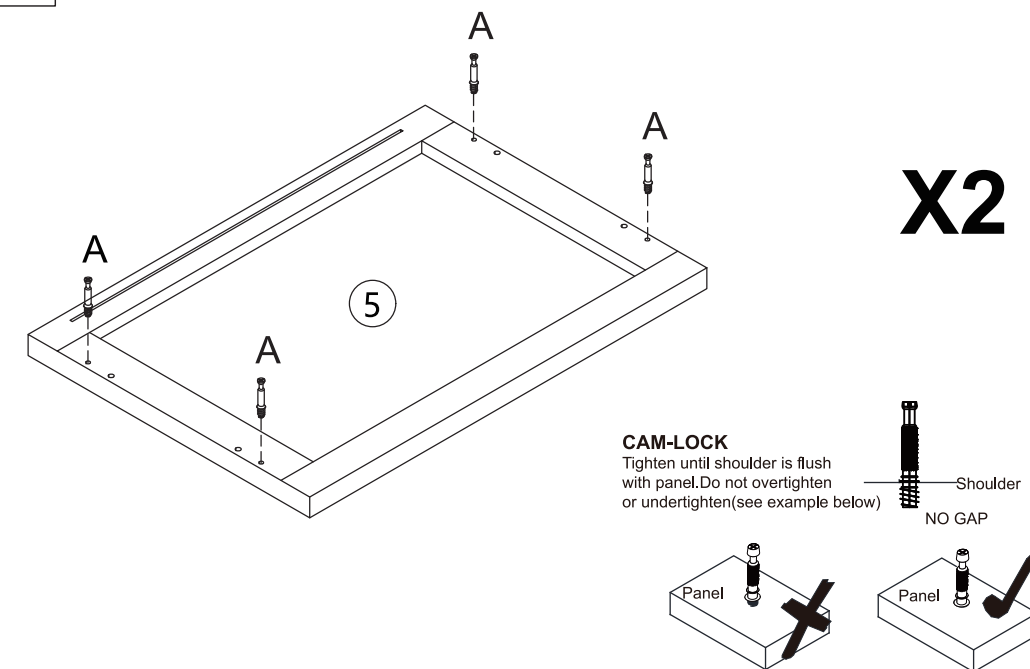

Screw hardware (A) into the holes of part (5).

Step 19

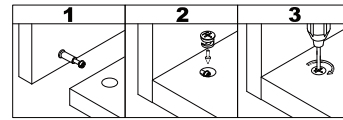
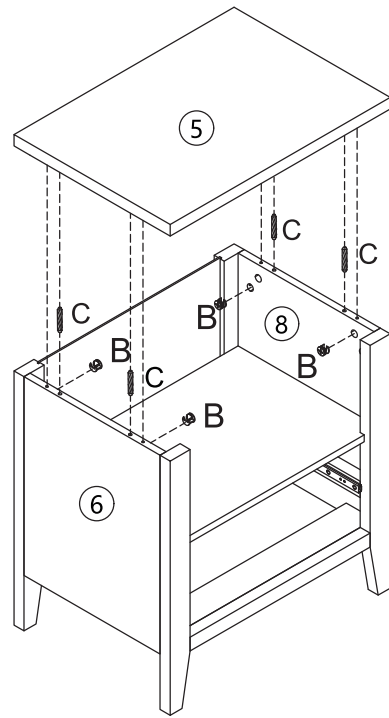
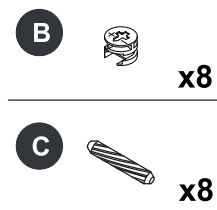

X2

Insert dowels (C) into parts (6) and (8), connect them to part (5), and secure with hardware (B).

Step 20

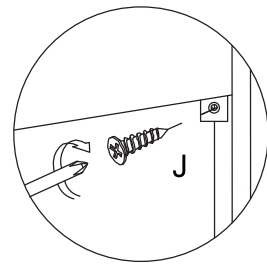
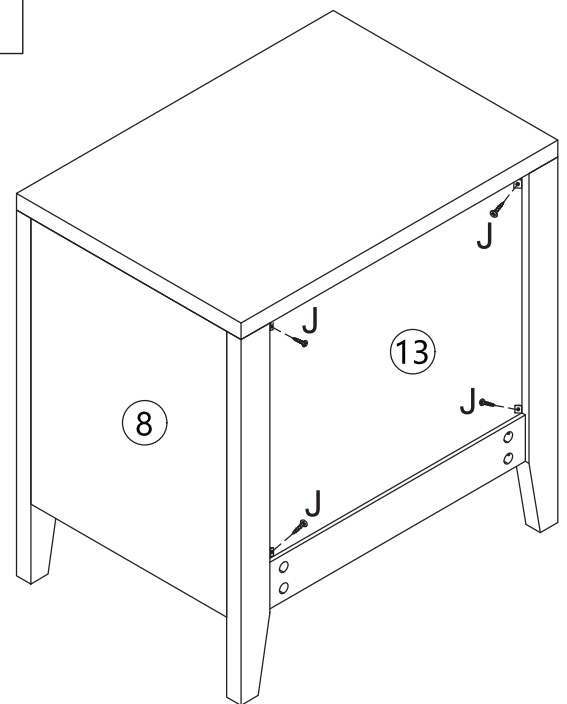

X2

Use screws (J) to secure the white clips to part (13), fixing the back panel in place.

Step 21

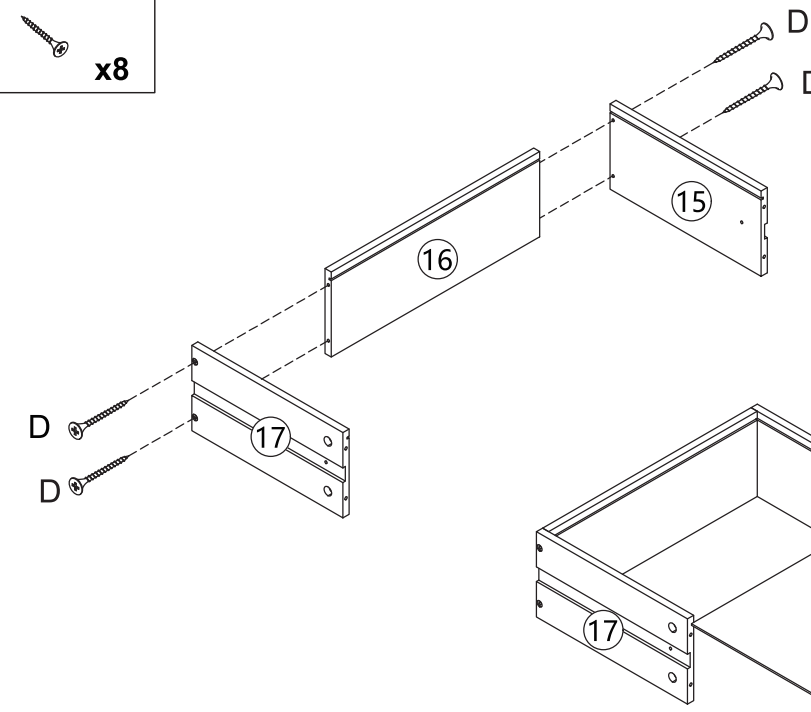

X2

1. Use screws (D) to connect parts (15), (16), and (17), securing them in place.
2. Insert part (18).

Step 22

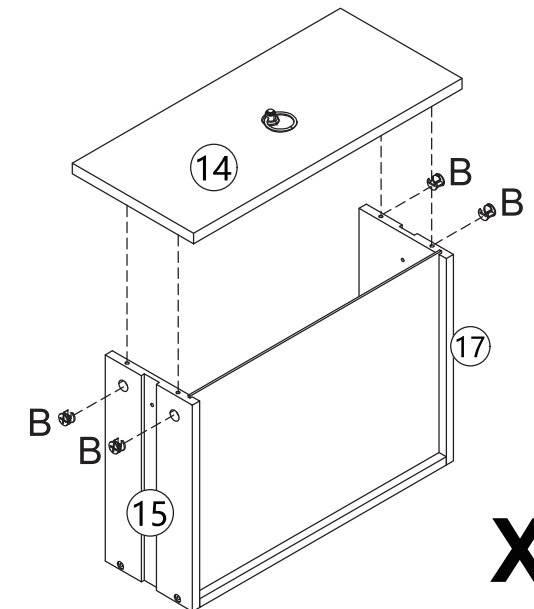
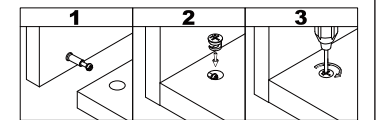
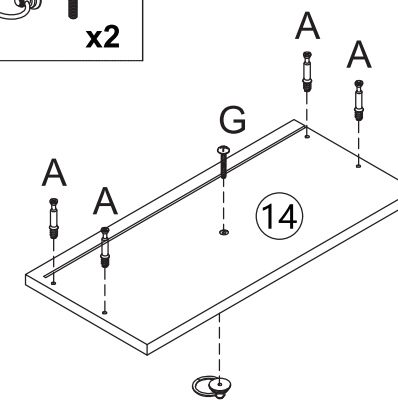
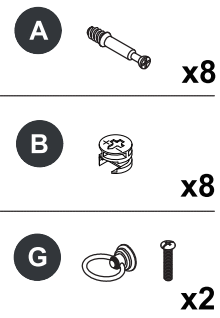

X2

1. Screw hardware (A) into the holes of part (14).
2. Install the handle using screws (G) into the middle hole.
3. Connect parts (14), (15), and (17), and secure them with hardware (B).

Step 23

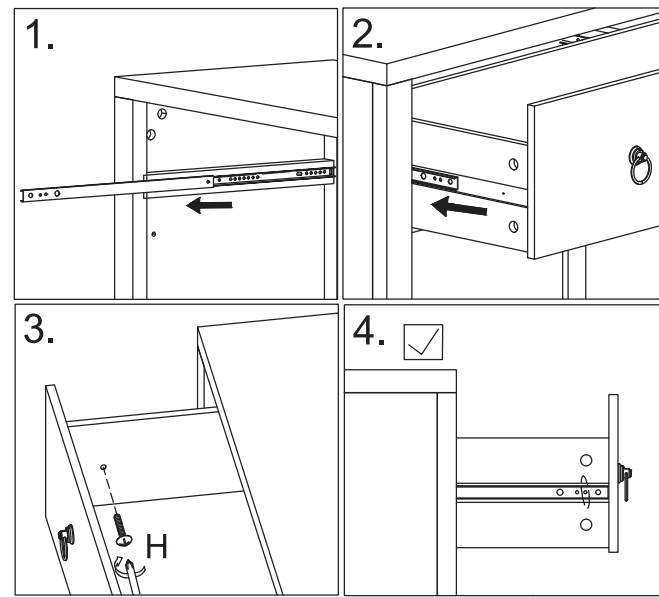
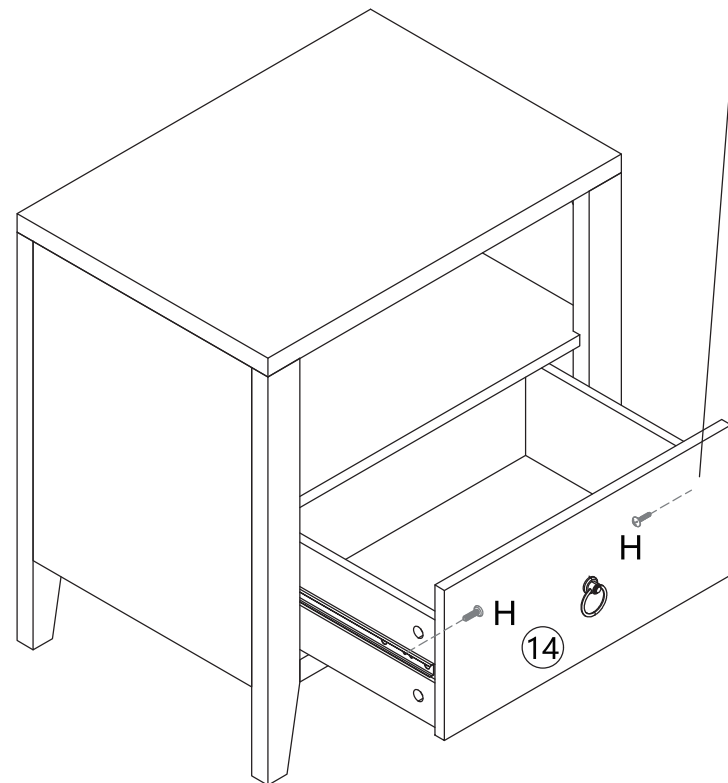
H
 x4
**X2**

1. Pull out the rail and push the groove on the side of the drawer into the rail track.
2. Use screws (H) to secure the rail from the inside of the drawer outward.
3. The rail holes are counted from right to left, using the second hole.

Step 24

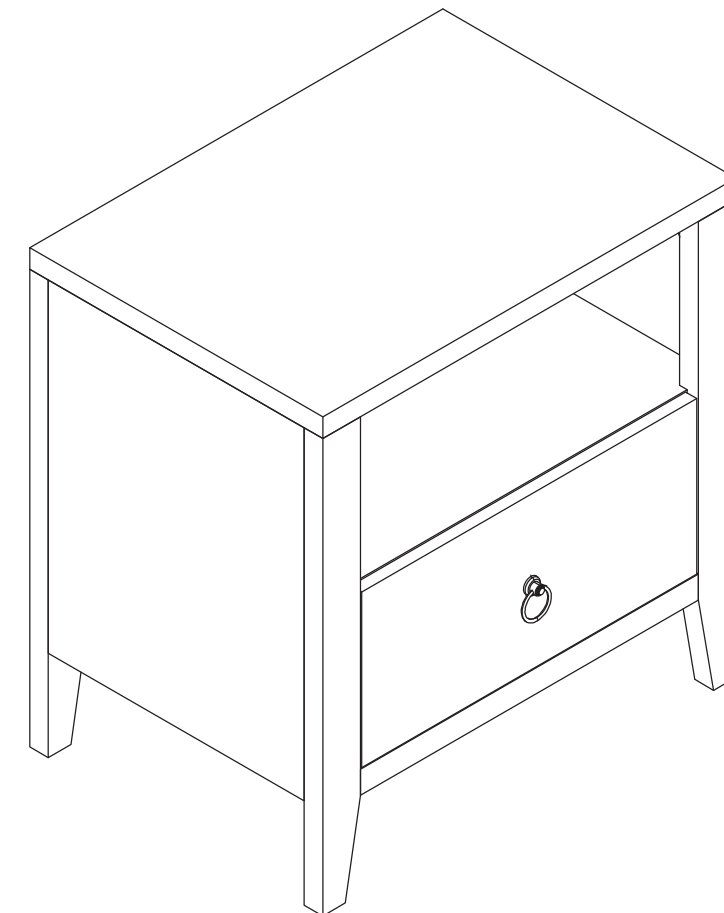

Assembly is complete