

INSTALLATION INSTRUCTIONS

L519S and L519L – 120V LED TRACK WALL WASH/FLOOD



Read and understand these instructions before installation

This product is intended for installation in accordance with the National Electric Code and local regulations. To assure full compliance with local codes and regulations, check with your local electrical inspector before installation.

To prevent electrical shock, turn off electricity at fuse box before proceeding.

No consumer serviceable parts. Contact factory if service is required.

For use in dry locations only.

Retain these instructions for maintenance reference.

Jesco luminaire compatibility is designated by its prefix (H2, L2 or J2). Refer to the appropriate instructions below for the product you have.

H2 Series

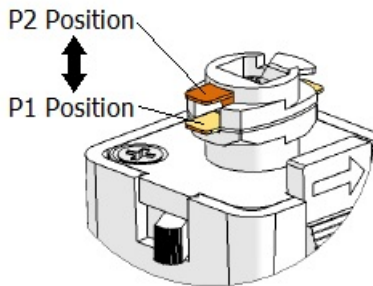

L2 Series

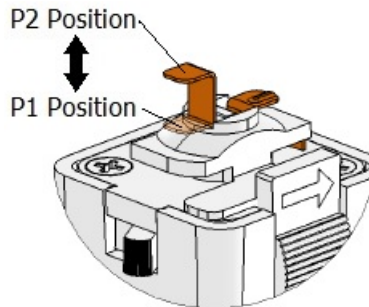

J2 Series

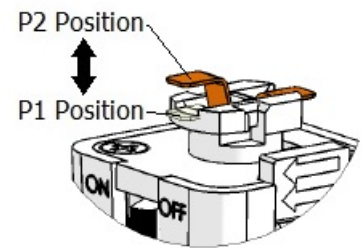

P1 = Lowered position. Single circuit track or circuit #1 of two circuit track. (Factory setting)

P2 = Raised position. Circuit #2 of two circuit track.

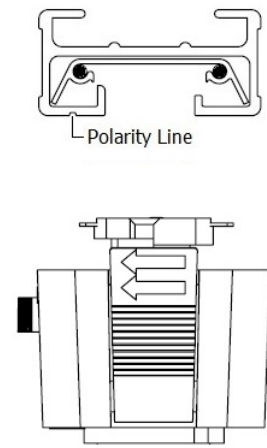
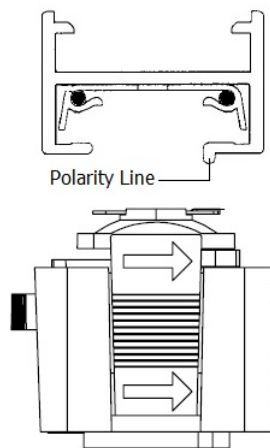
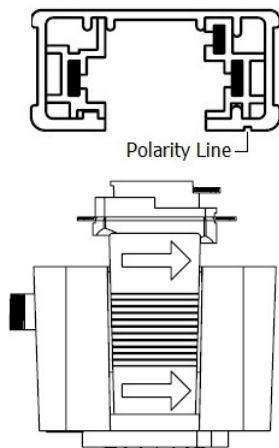

Identifying Polarity

Note the raised polarity indicating arrow on each type of adaptor. This arrow points to the polarity line when installed.

CAUTION

RISK OF ELECTRICAL SHOCK

DAMAGE TO TRACK AND ADAPTOR IF ORIENTATION IS INCORRECT

INSTALLATION INSTRUCTIONS

L519S and L519L – 120V LED TRACK WALL WASH/FLOOD

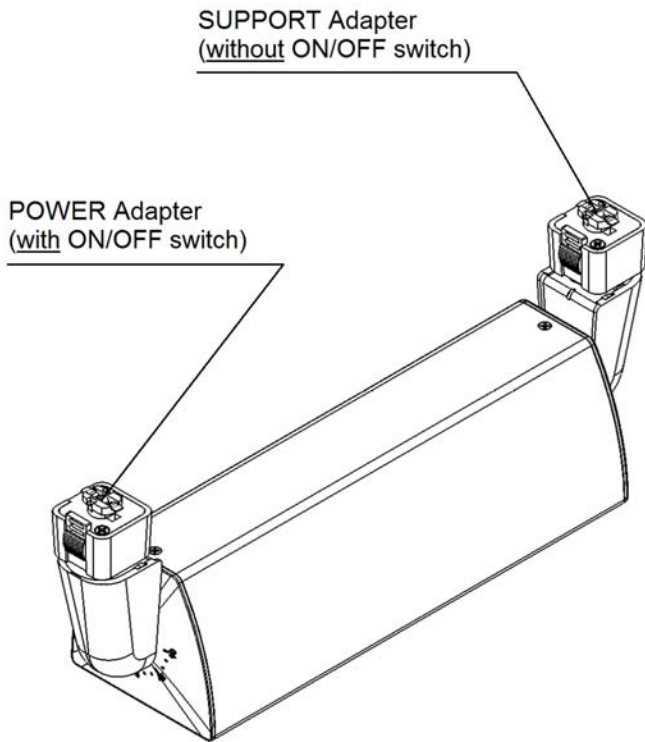

ATTACHING LUMINAIRE TO TRACK

1. Identify the POWER adapter (with ON/OFF switch) and SUPPORT adapter (without ON/OFF switch).
2. Disengage LOCKING TAB on POWER adapter by pulling it downward.
3. With LOCKING TAB disengaged, rotate the POWER adapter 90° clockwise until it is in position.
4. Release LOCKING TAB, make certain it is locked.
5. Repeat steps 2 thru 4 for SUPPORT adapter.

REMOVING LUMINAIRE FROM TRACK

1. Disengage LOCKING TAB on SUPPORT adapter by pulling it downward.
2. With LOCKING TAB disengaged, rotate the SUPPORT adapter 90° counterclockwise.
3. Repeat steps 1 thru 2 for POWER adapter and then remove.

NOTE

- See Page 1 for system specific orientation.
- Consult factory for compatibility to other manufacturer's track system.
- If you encounter resistance when rotating the adaptor, check orientation of adaptor to track.

ATTACHING LOUVER TO LUMINAIRE

1. Align and insert Side A of louver to luminaire.
2. Disengage SPRING CLIP on Side B.
3. Release SPRING CLIP, make certain louver is installed securely to luminaire.

REMOVING LOUVER FROM LUMINAIRE

1. Disengage SPRING CLIPS on Side B.
2. Remove louver from luminaire.

