

Step1:On a clean smooth surface,gently turn the seat bottom faced to you. Screw feet (D) to seat frame (C) by turning clockwise .Loose of tight feet to adjust height if floor is not flat .

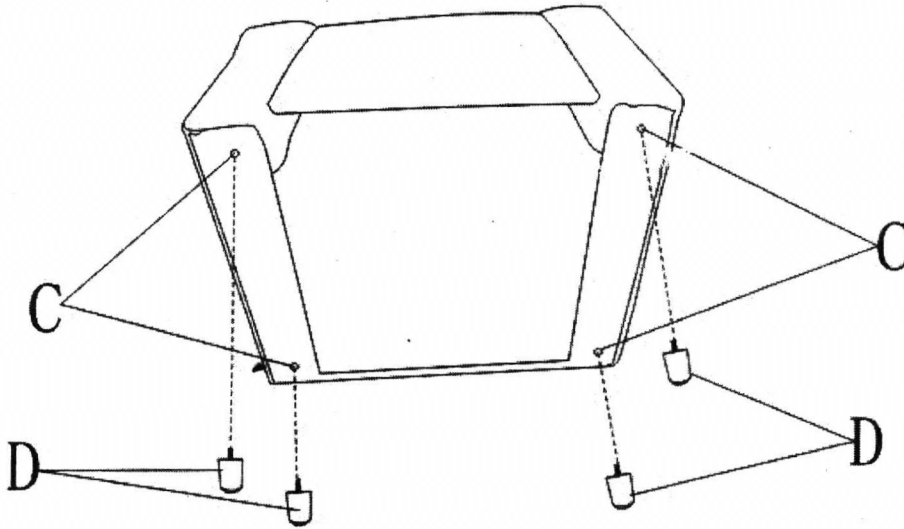

Step2:

Attach back frame (A) to seat frame (B) by sliding the brackets on the back frame(A) into the back brackets on the seat frame(B)

Place the flap into the position using the velcro strips once the back frame has been locked into place.

Note:both sides must be inserted into the base at the same time. The step is best proformed with 2people.

