

Shoe Bench

Instruction Manual

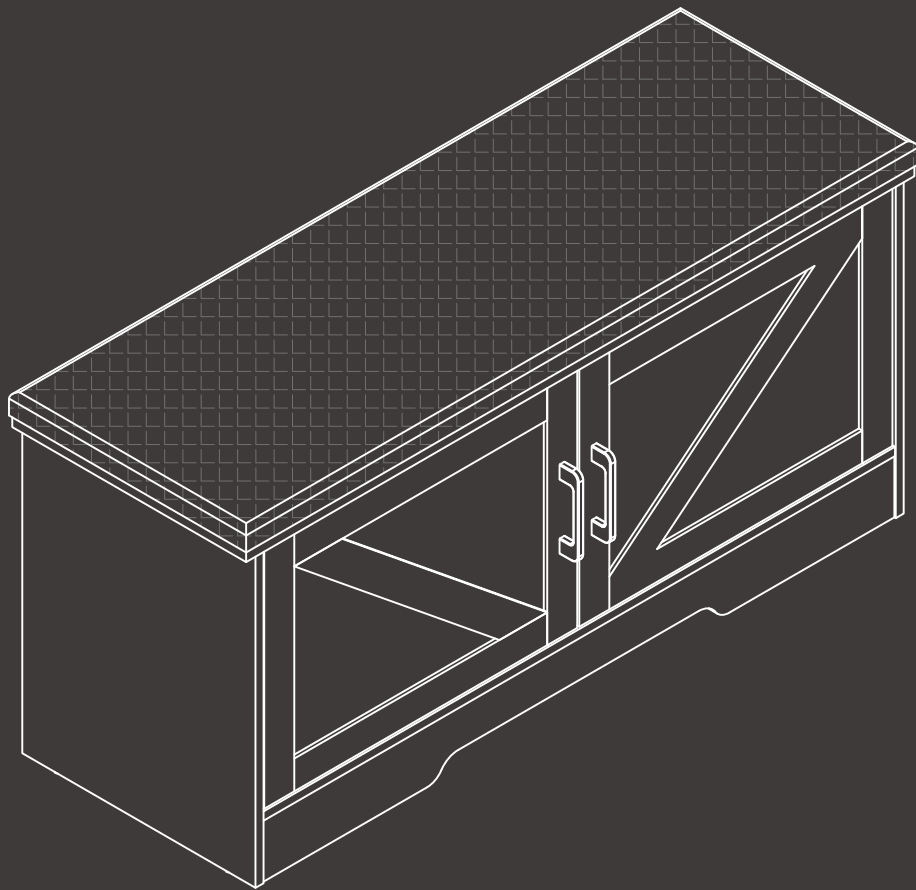

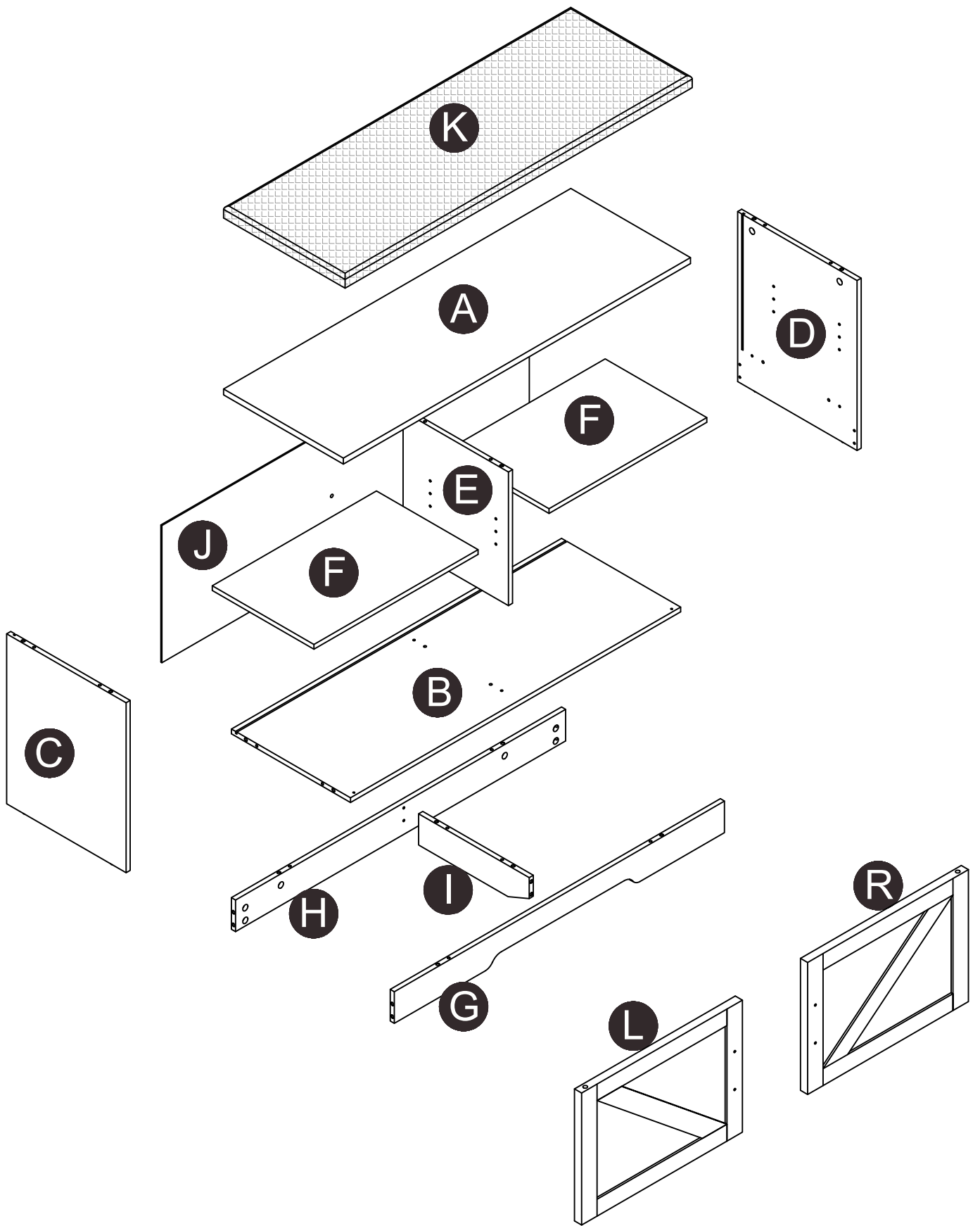

PARTS LIST

A x1

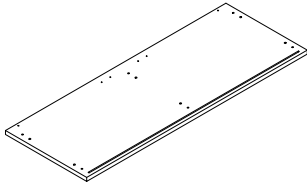

B x1

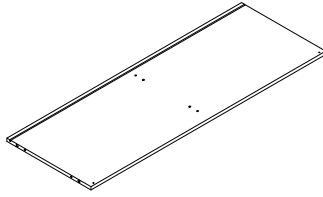

C x1

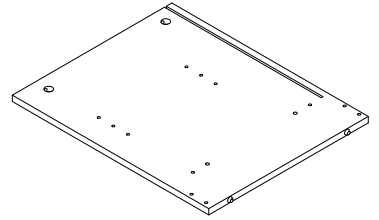

D x1

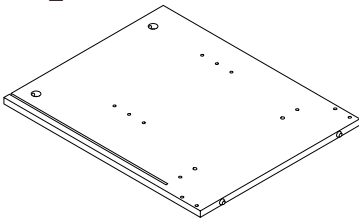

E x1

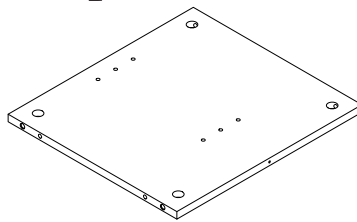

F x2

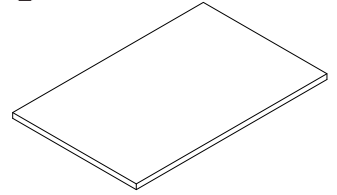

G x1

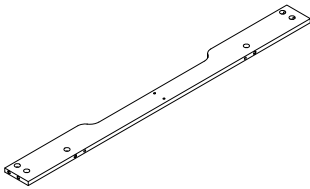

H x1

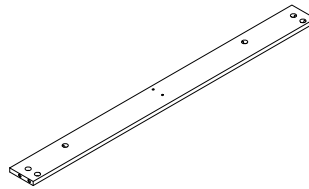

I x1

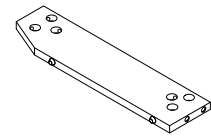

J x1

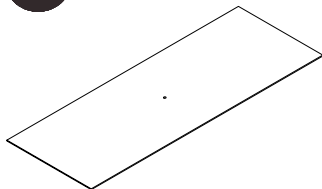

L x1

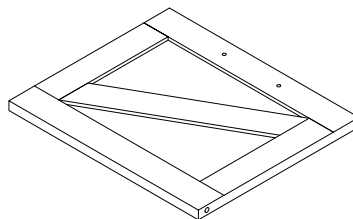

R x1

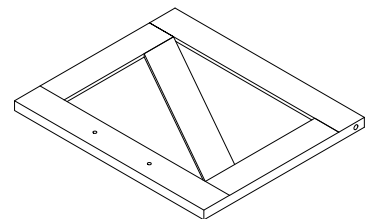

K x1

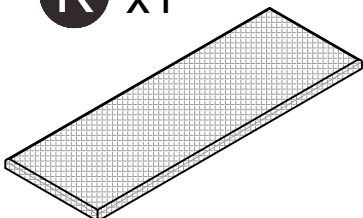

HARDWARE

1 x30

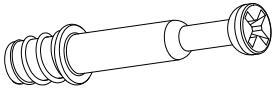

Ø6x35mm

2 x30

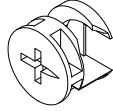

Ø15x10mm

3 x18

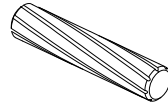

Ø6x30mm

4 x4

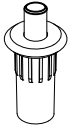

5 x1

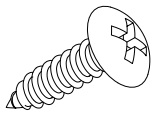

Ø4x14mm

6 x4

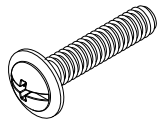

M4x18mm

7 x2

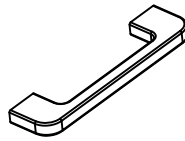

8 x10

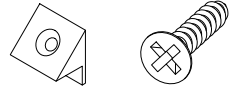

Ø6x3x16mm

9 x2

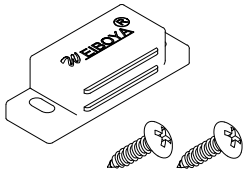

Ø6x3x14mm

10 x2

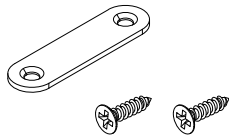

Ø6x3x12mm

11 x8

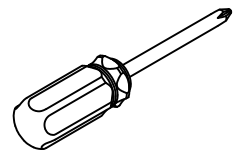
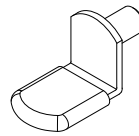

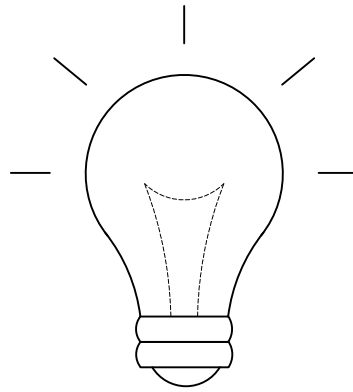

Friendly Reminder

To avoid errors during assembly, use the correct type and quantity of hardware as indicated in the instructions. Before starting, unroll the hardware bag, cut open the side, and lay out all parts for easy access.

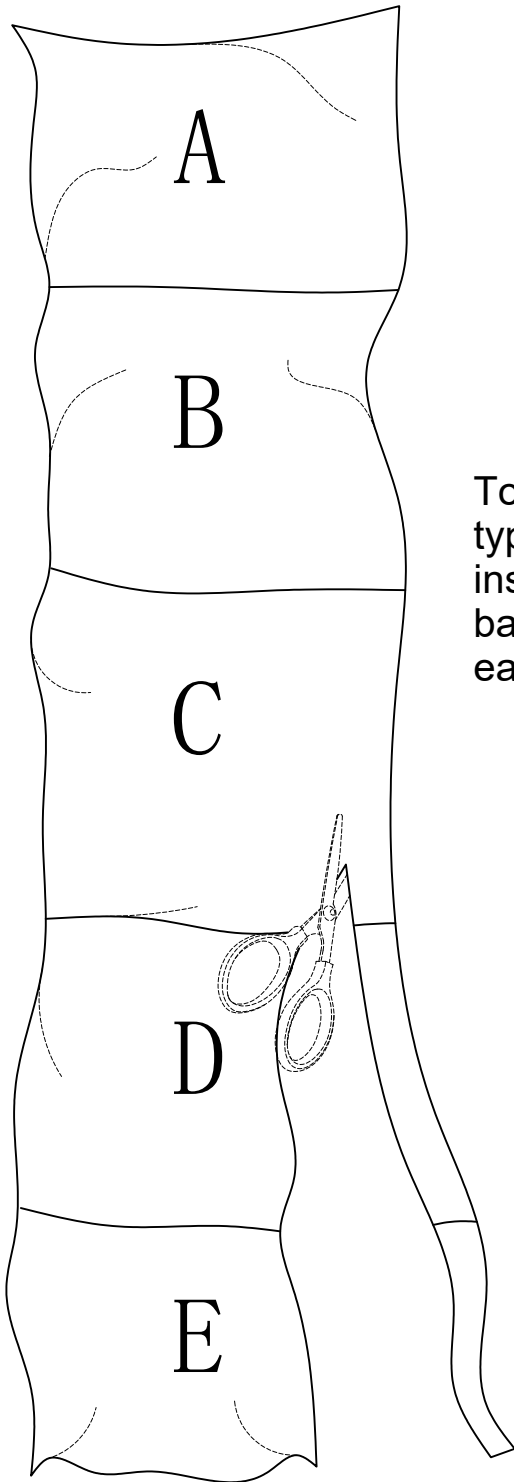

Step 1

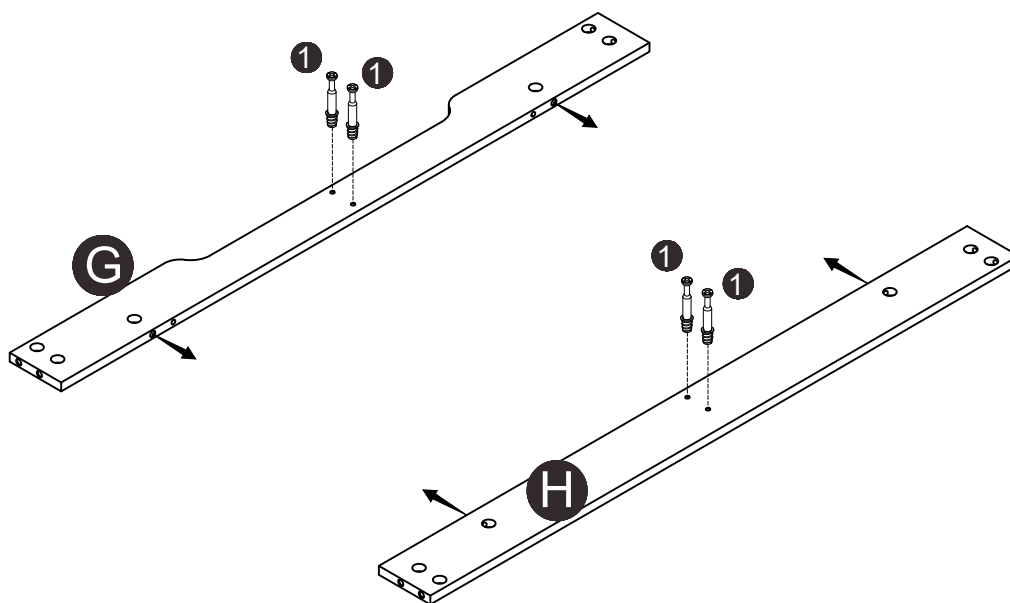
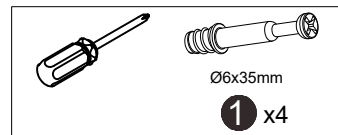

Step 2

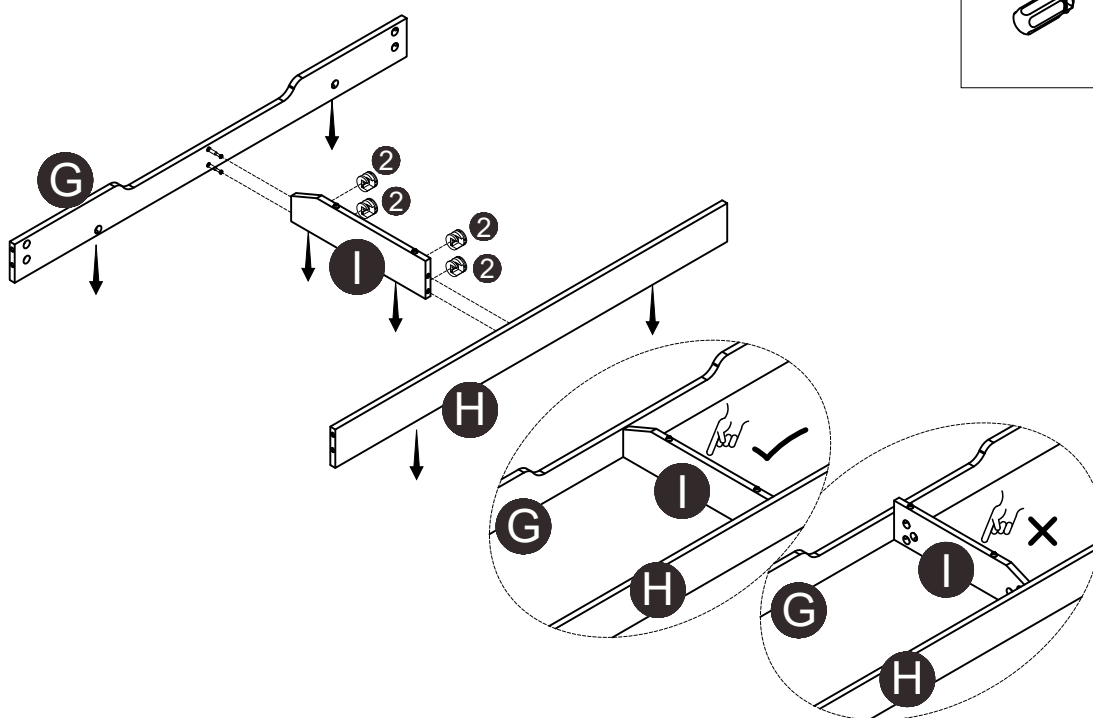
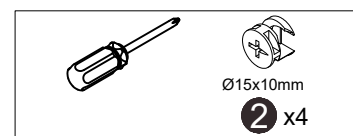

Step 3

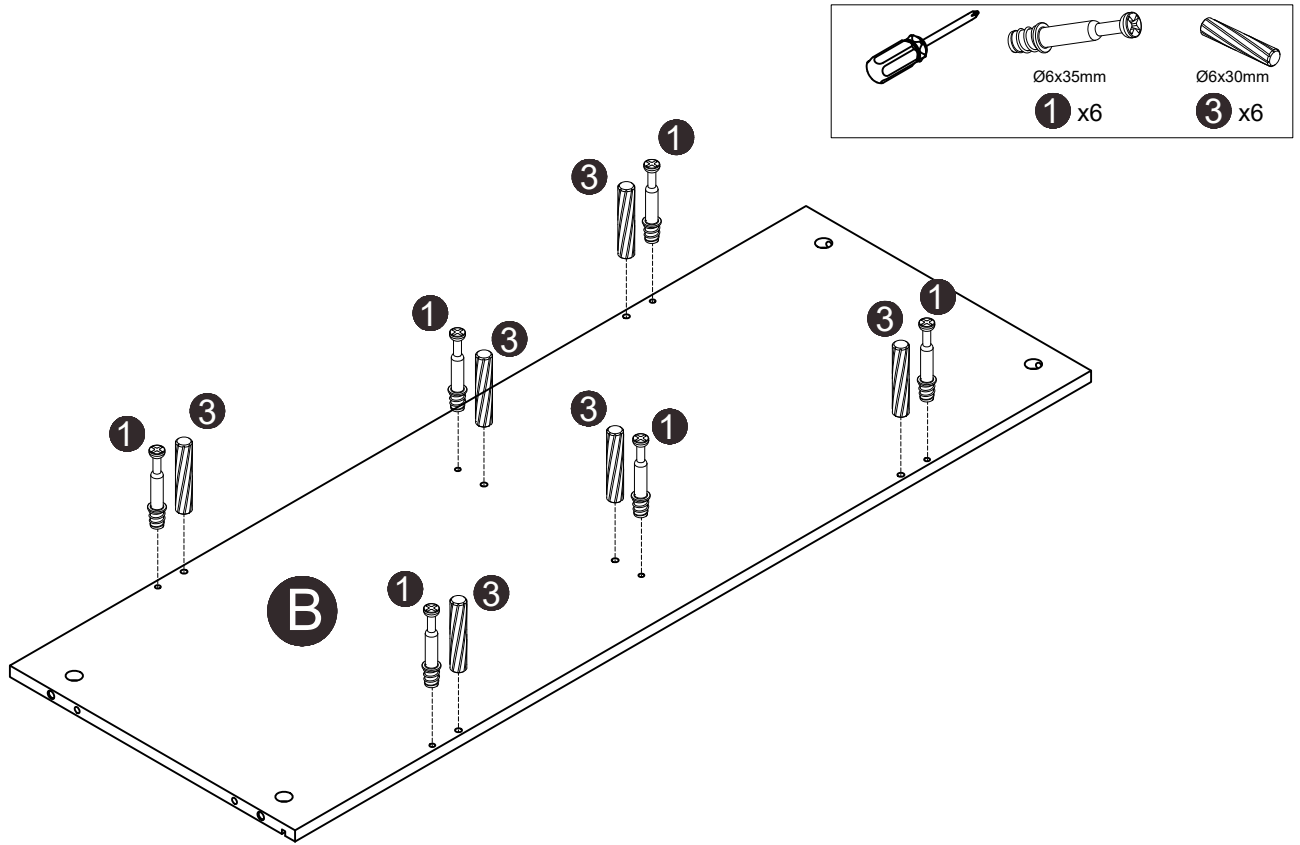

Step 4

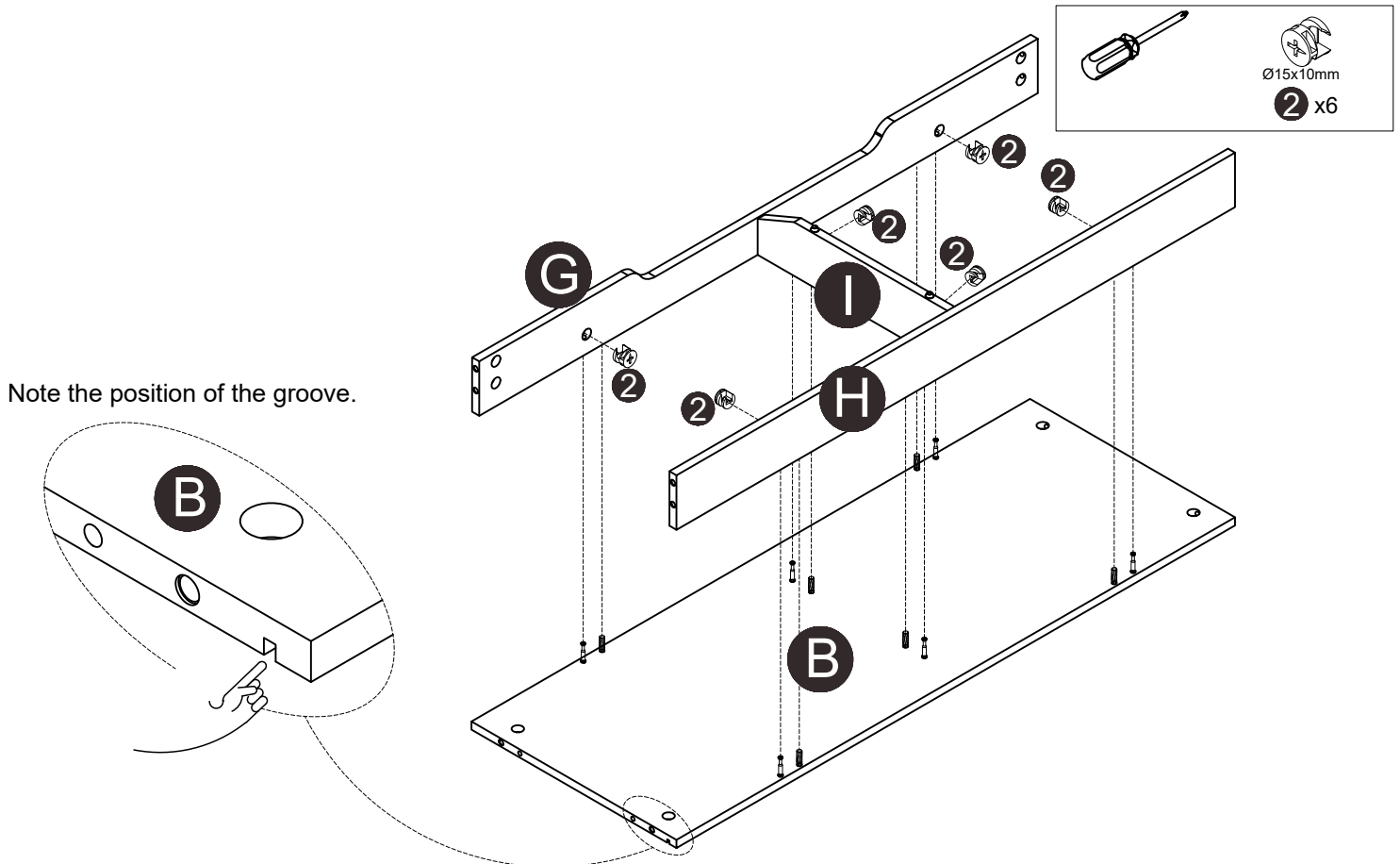

Step 5

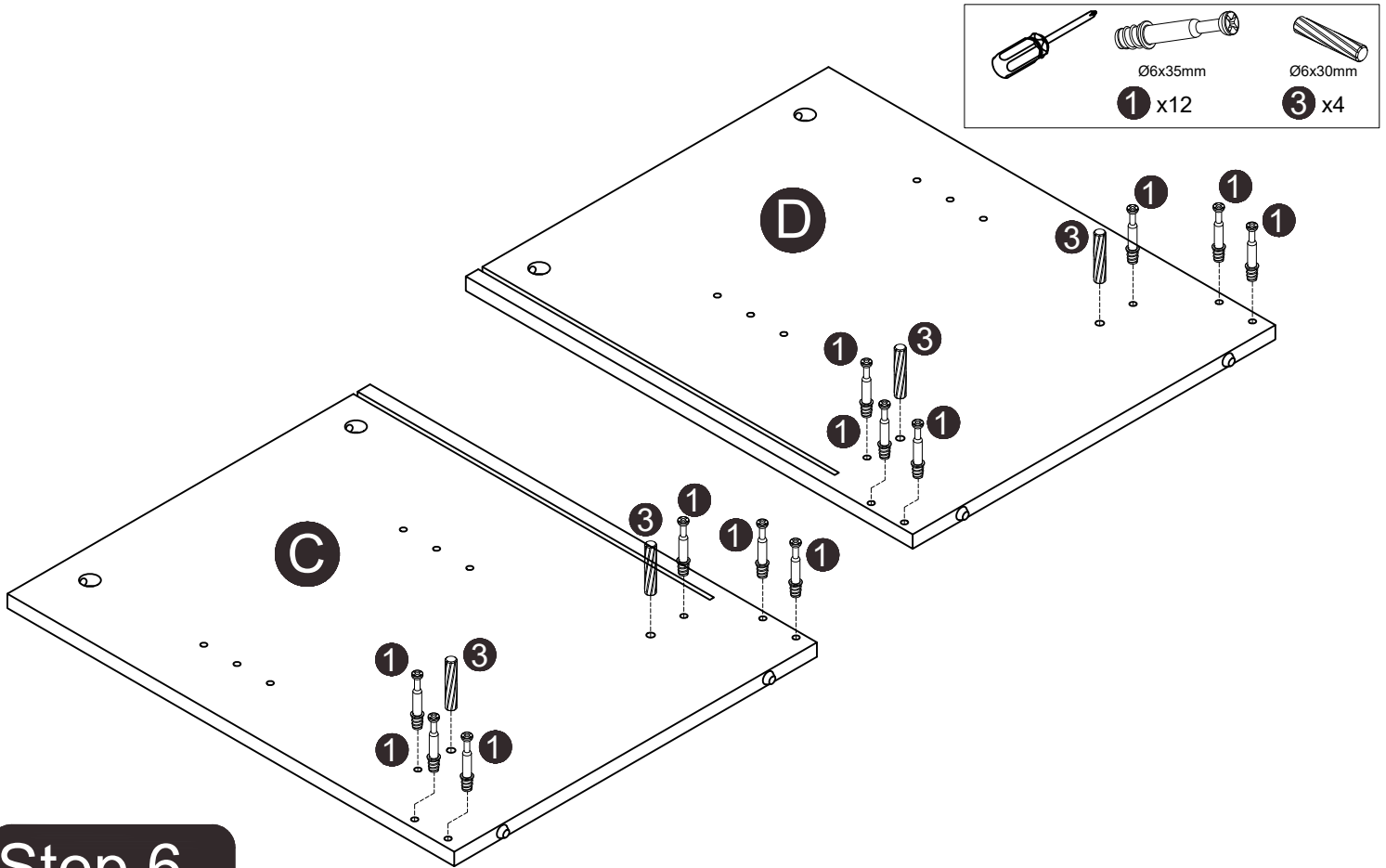

Step 6

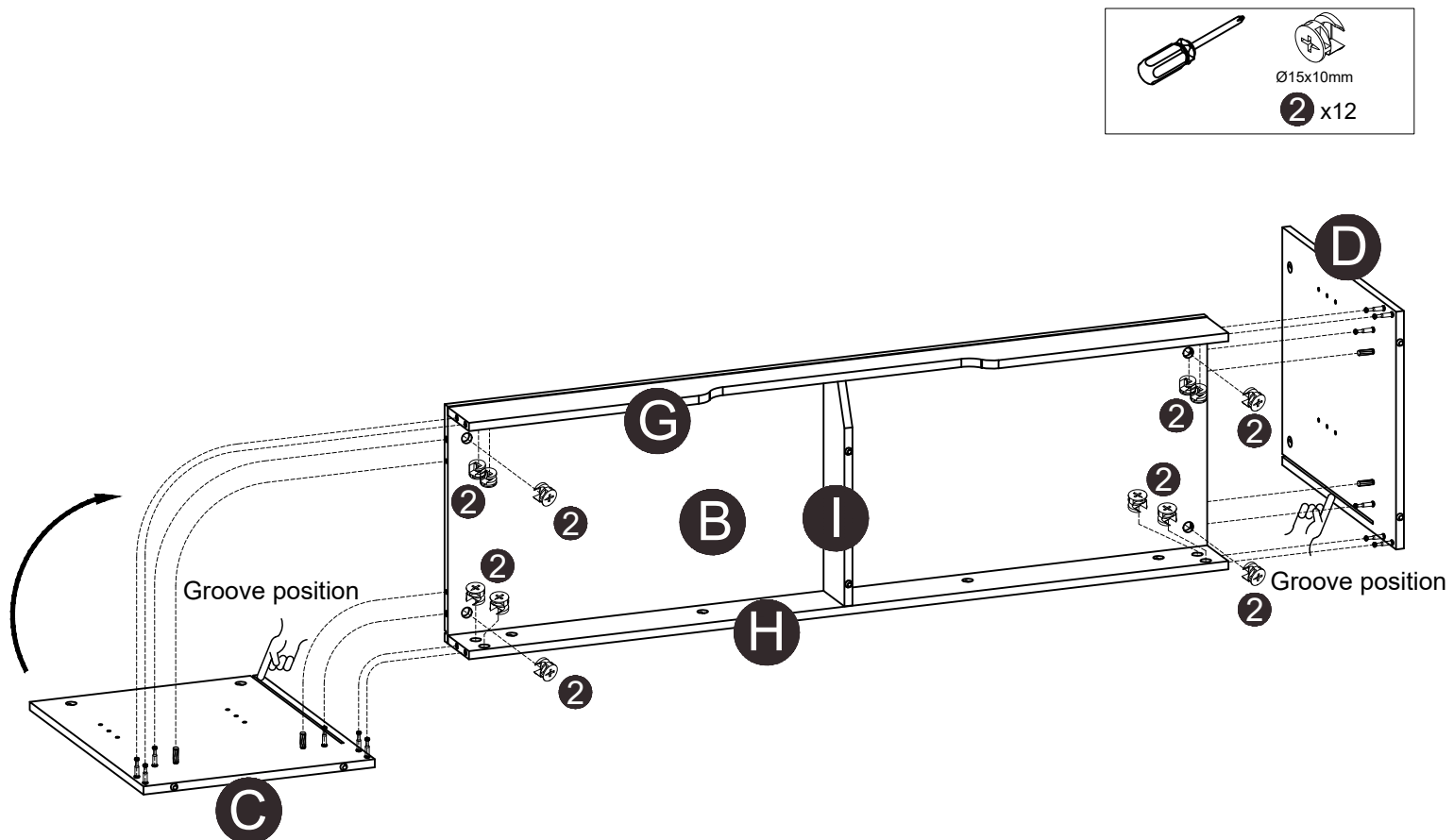

Step 7

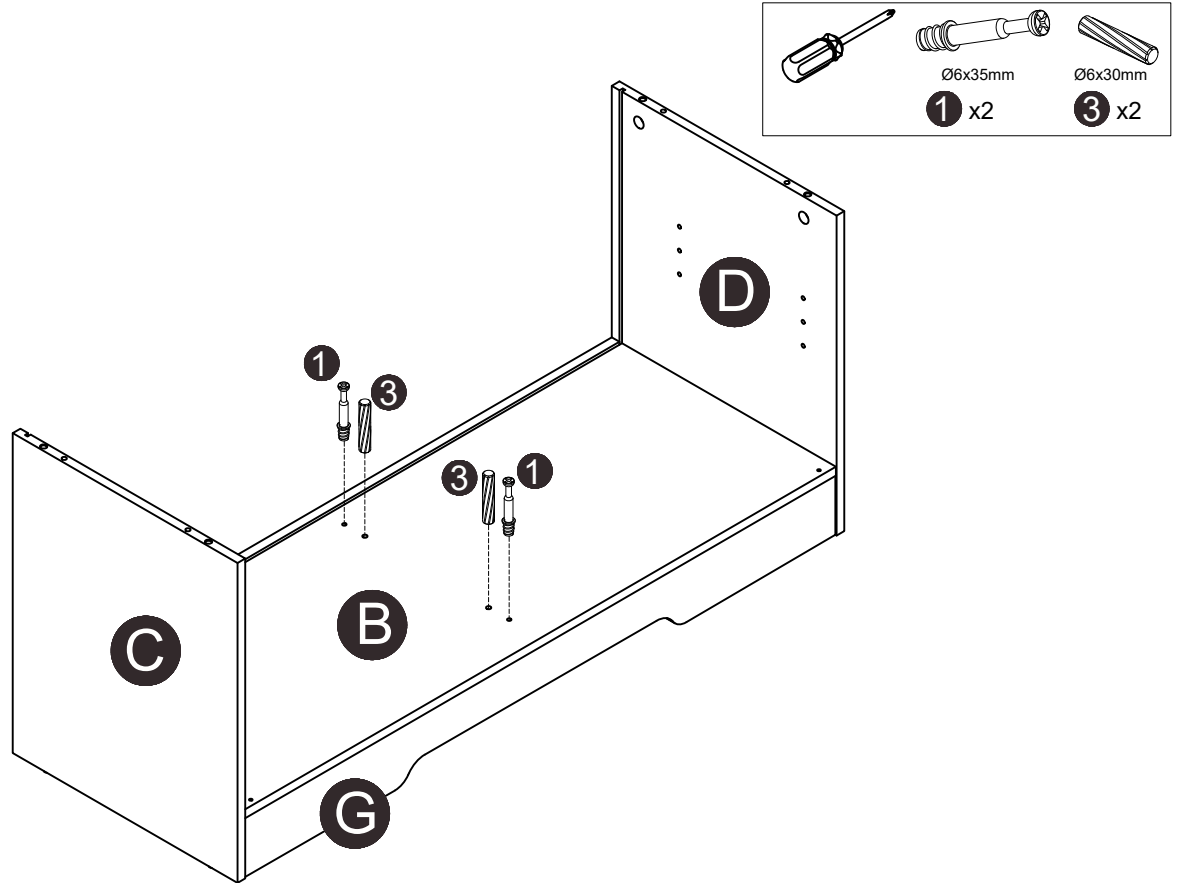

Step 8

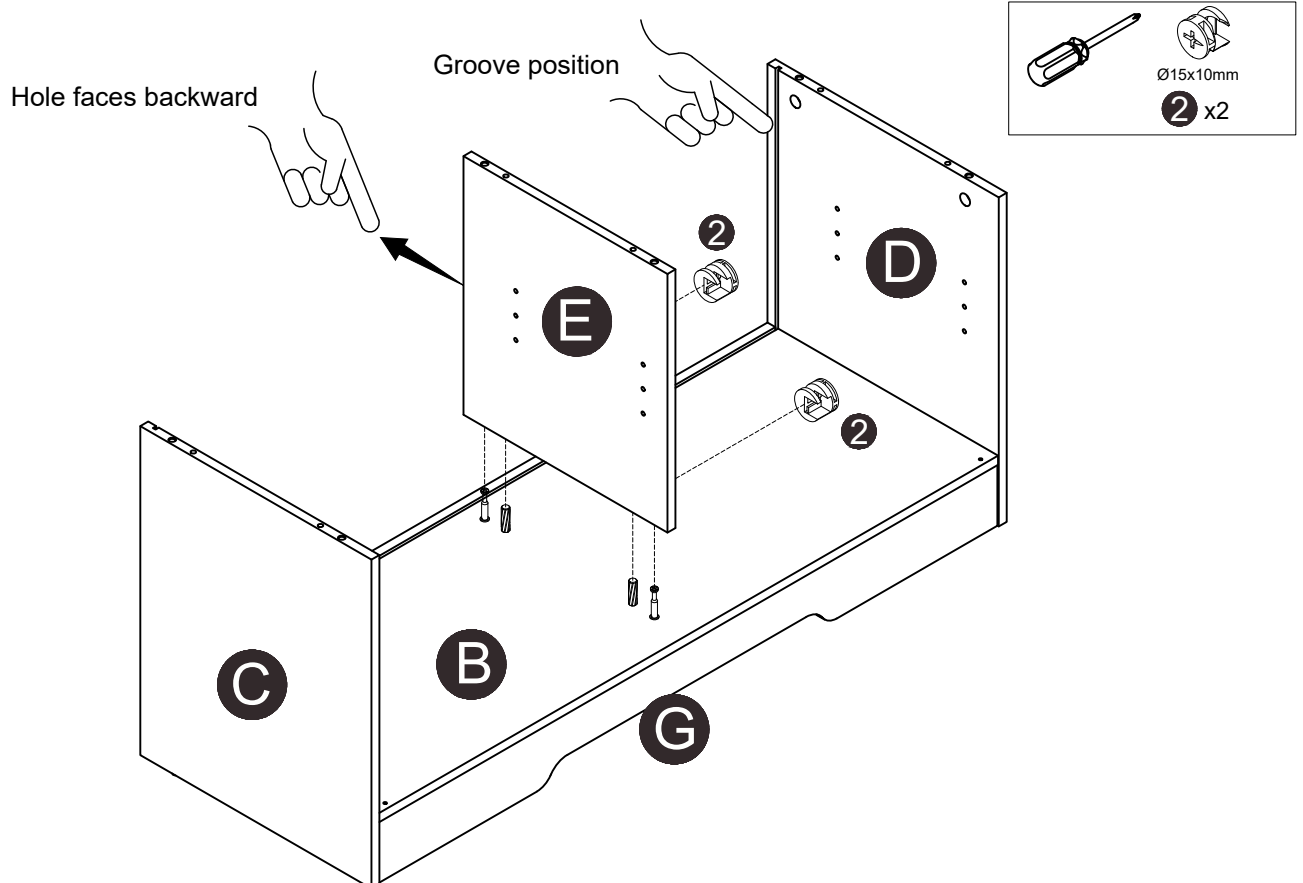

Step 9

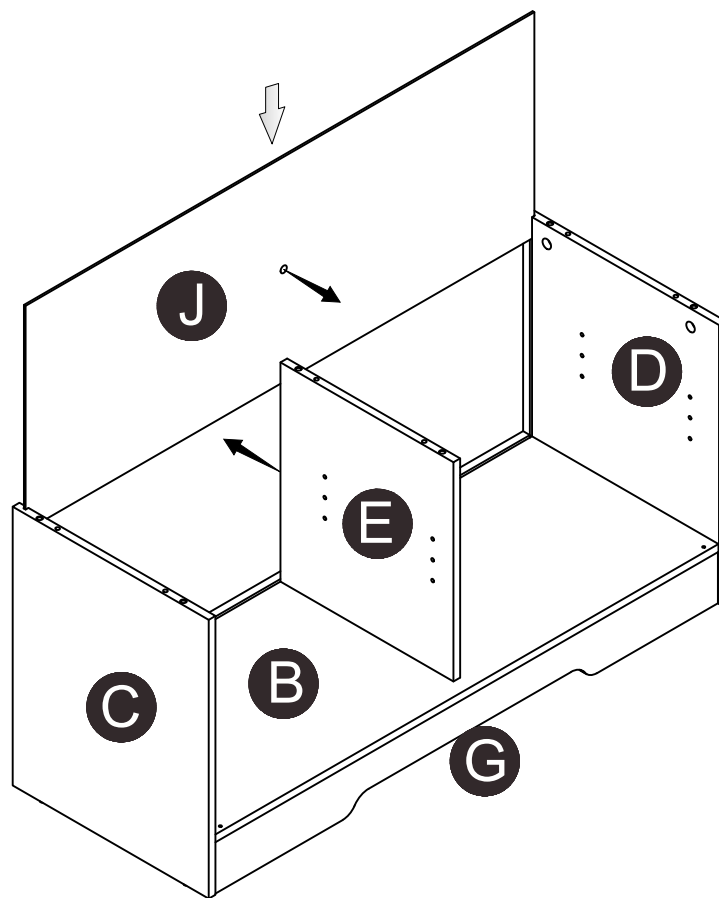

Step 10

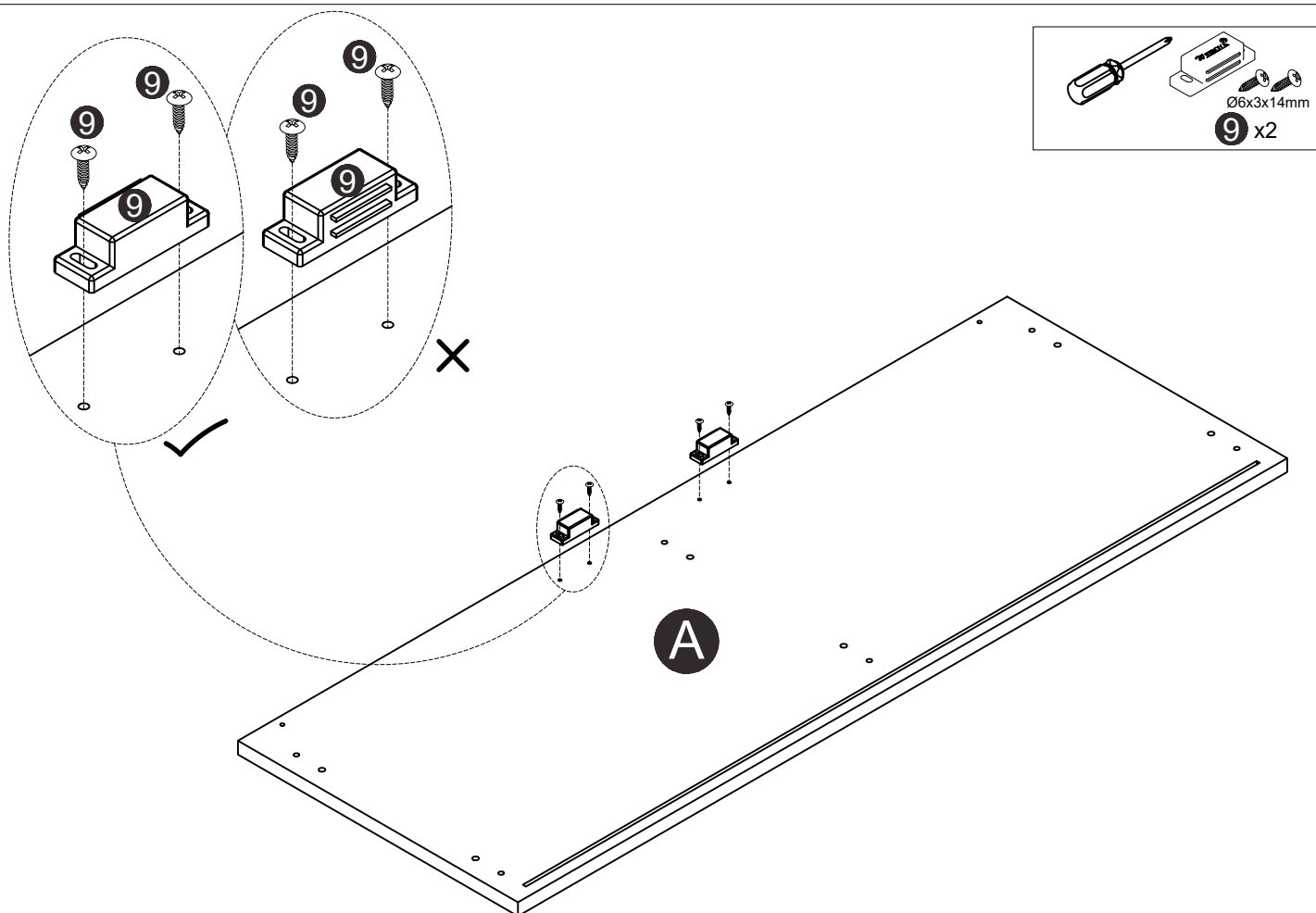

Step 11

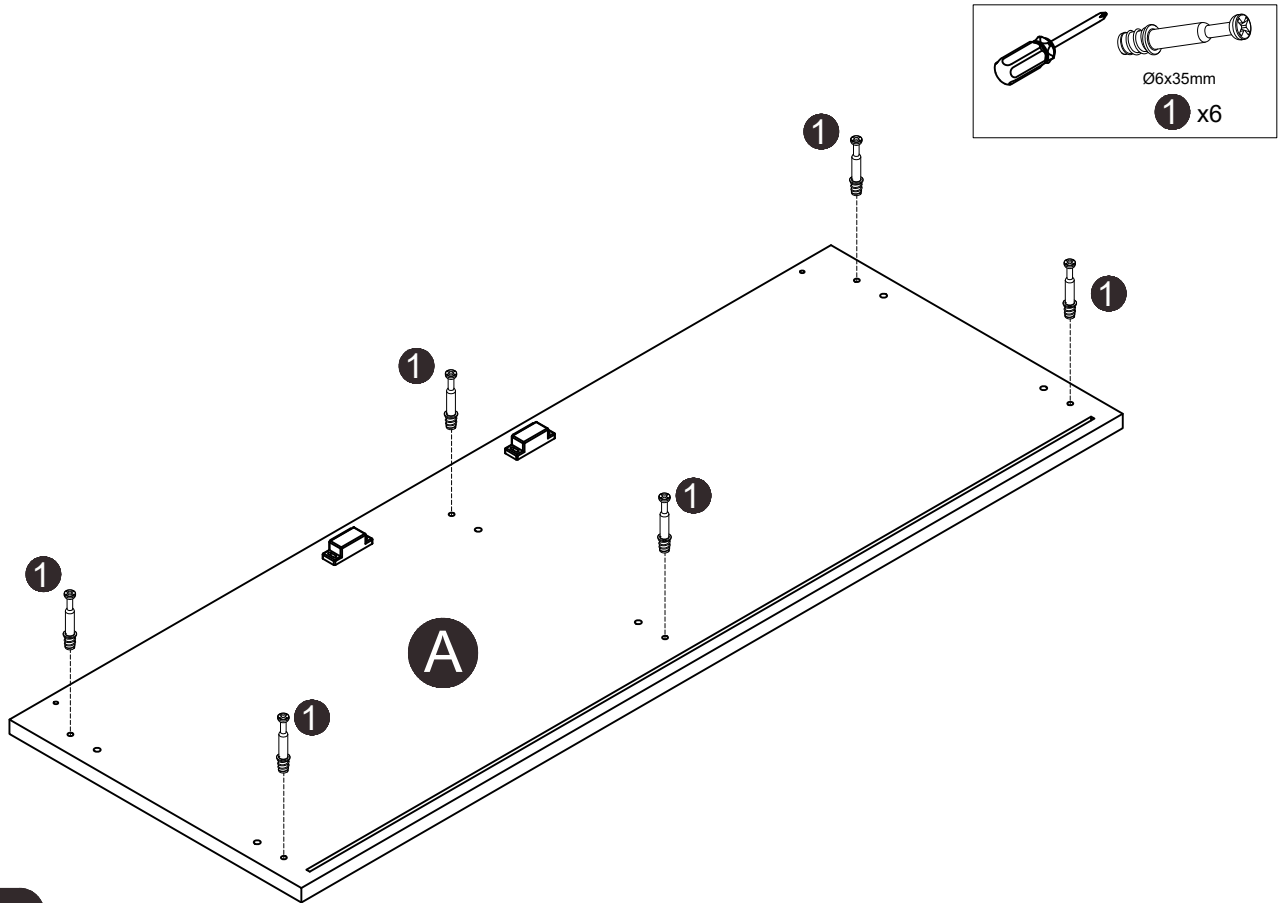

Step 12

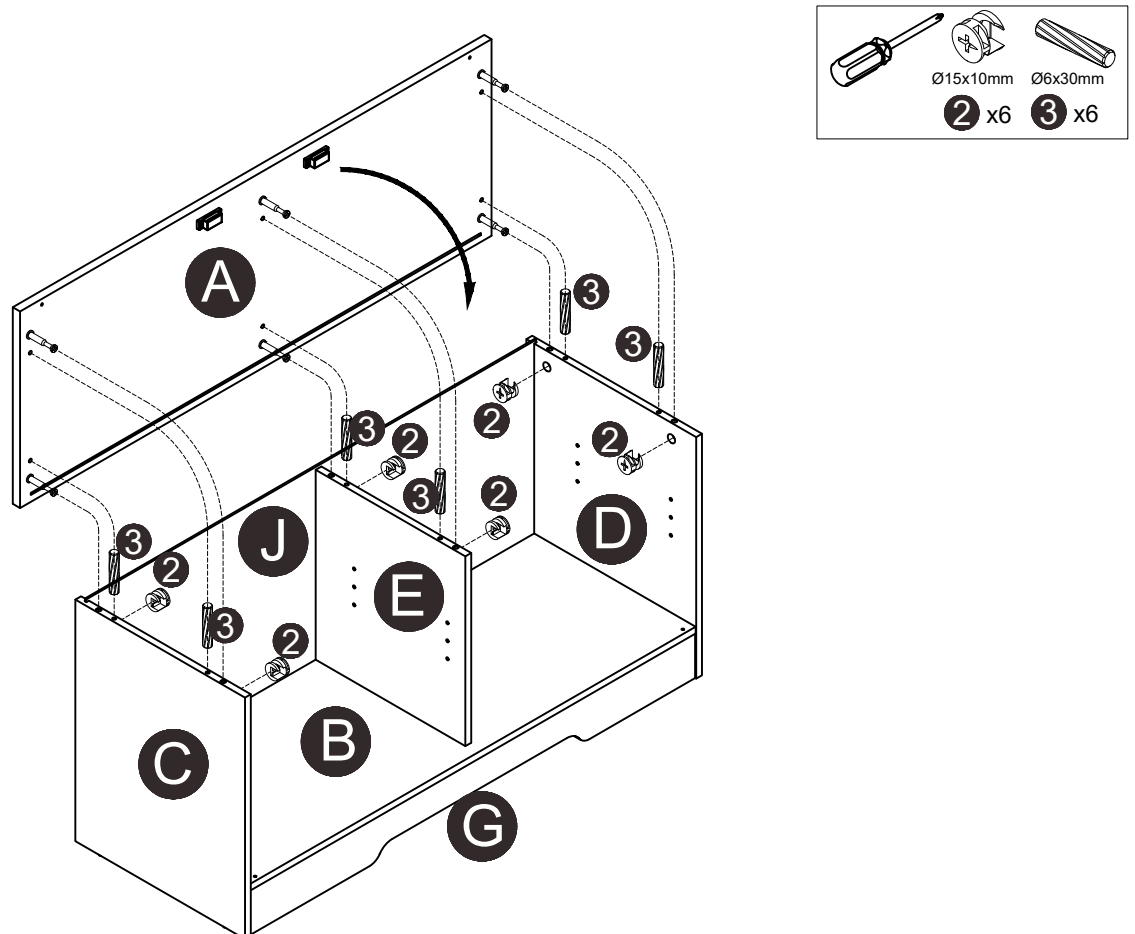

Step 13

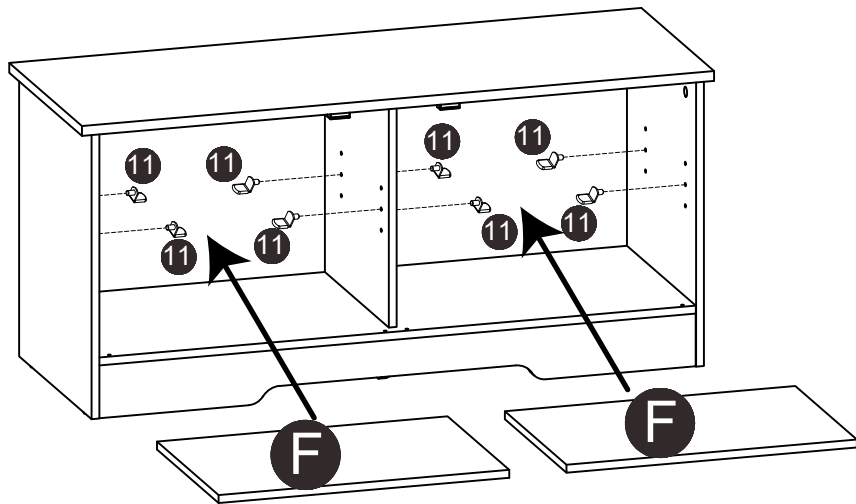
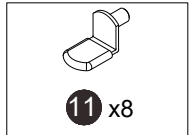
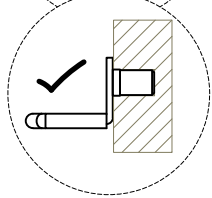
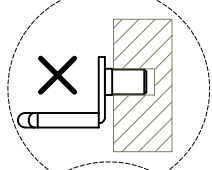
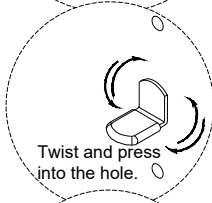
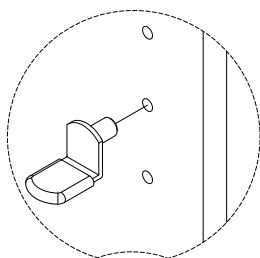

Step 14

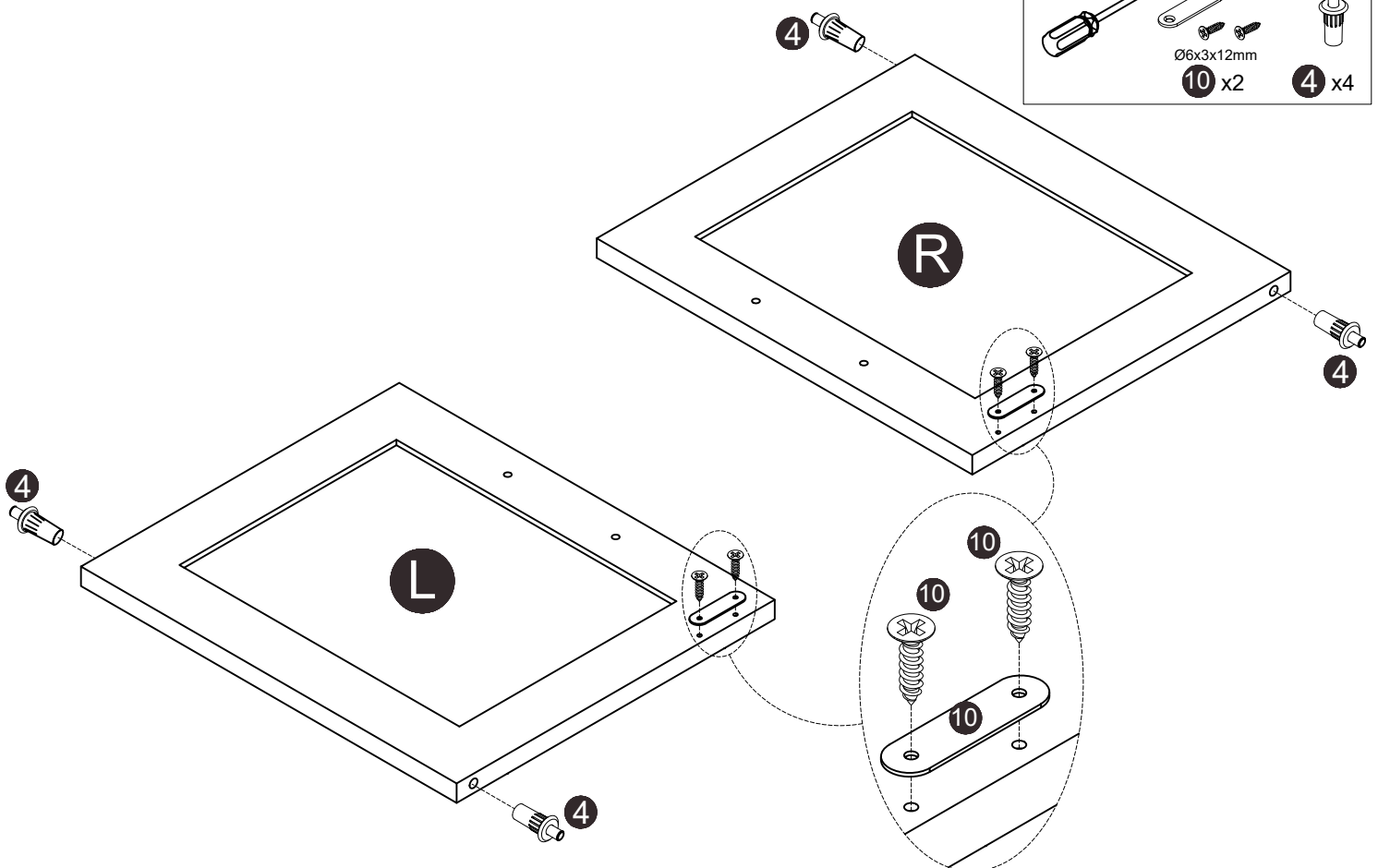
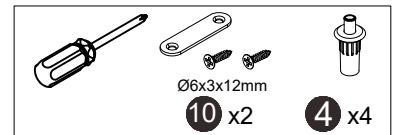

Step 15

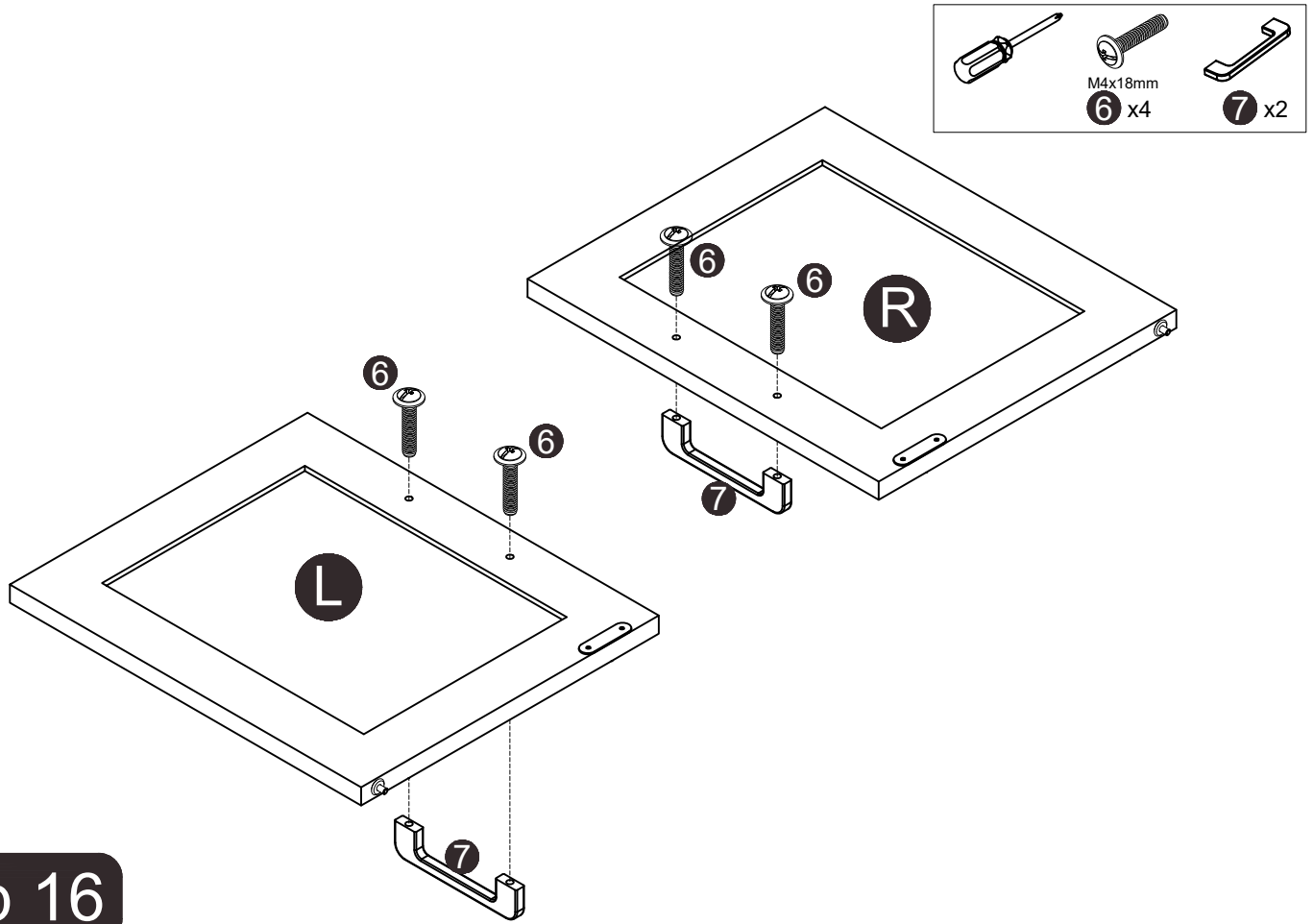

Step 16

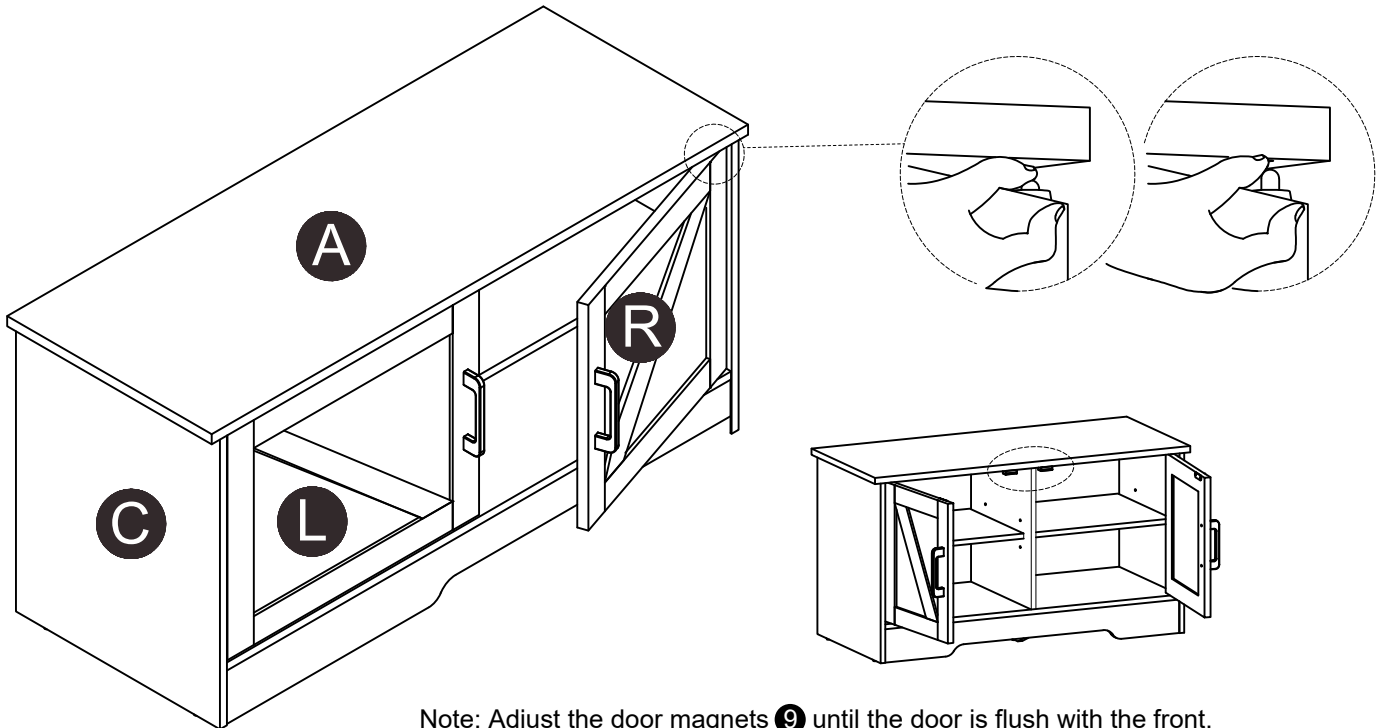

Note: Adjust the door magnets 9 until the door is flush with the front.

Step 17

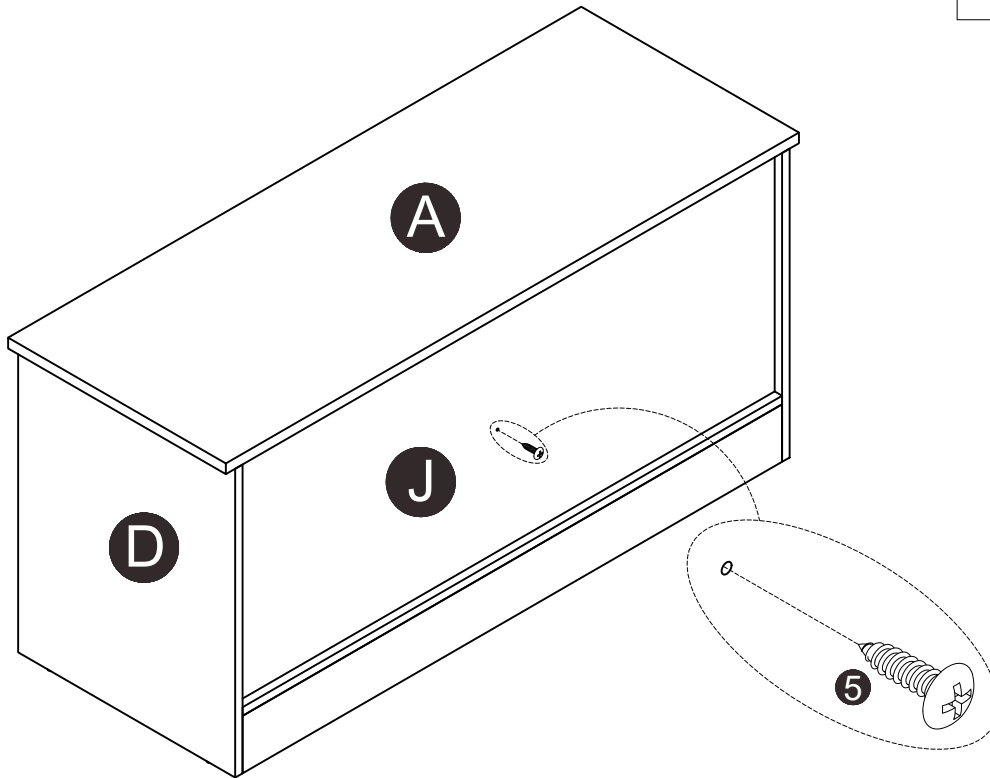
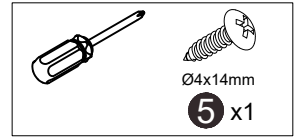

Step 18

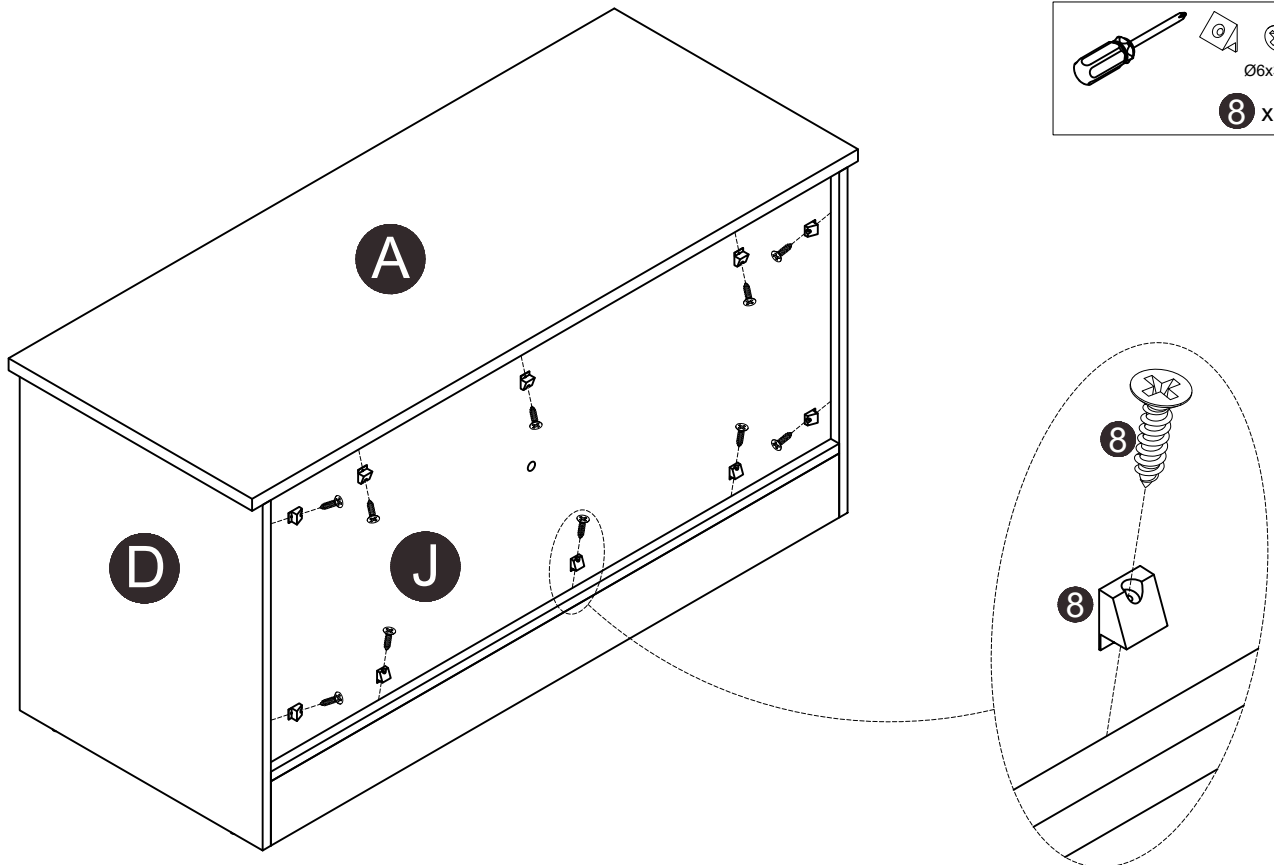
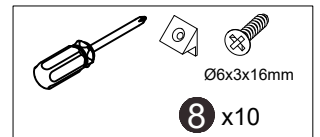

Step 19

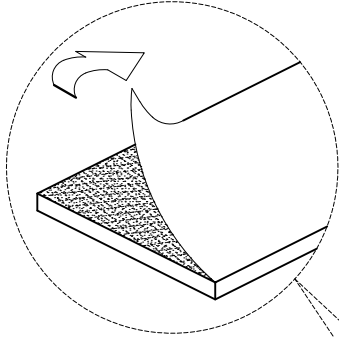

Remove the film from the surface

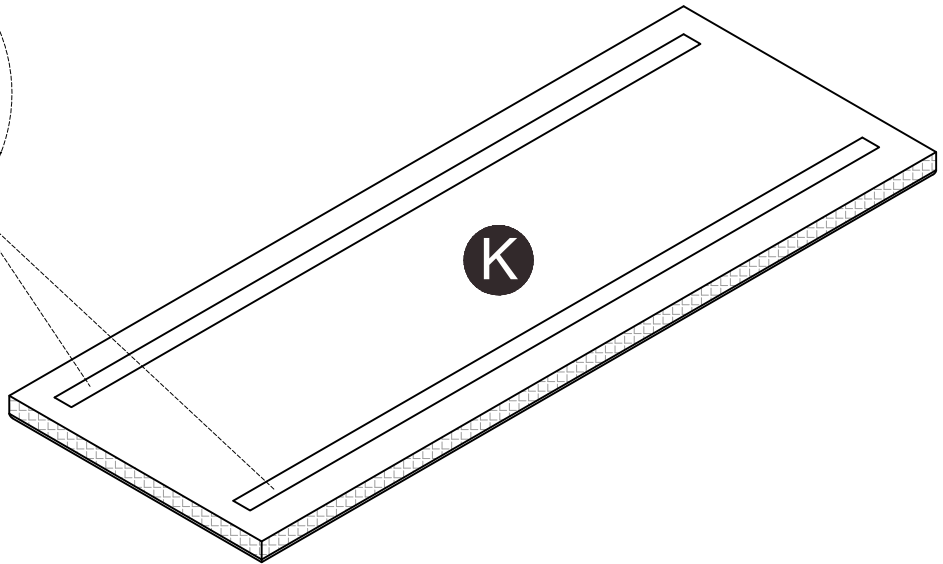

Step 20

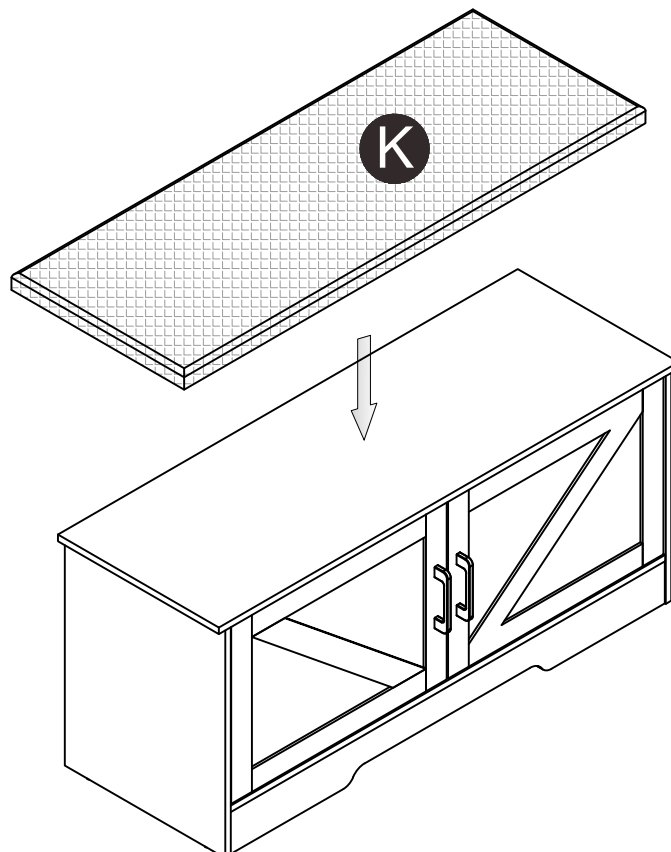
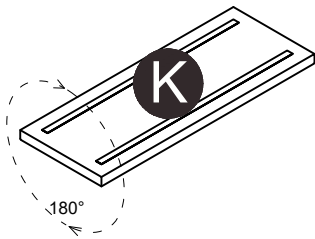

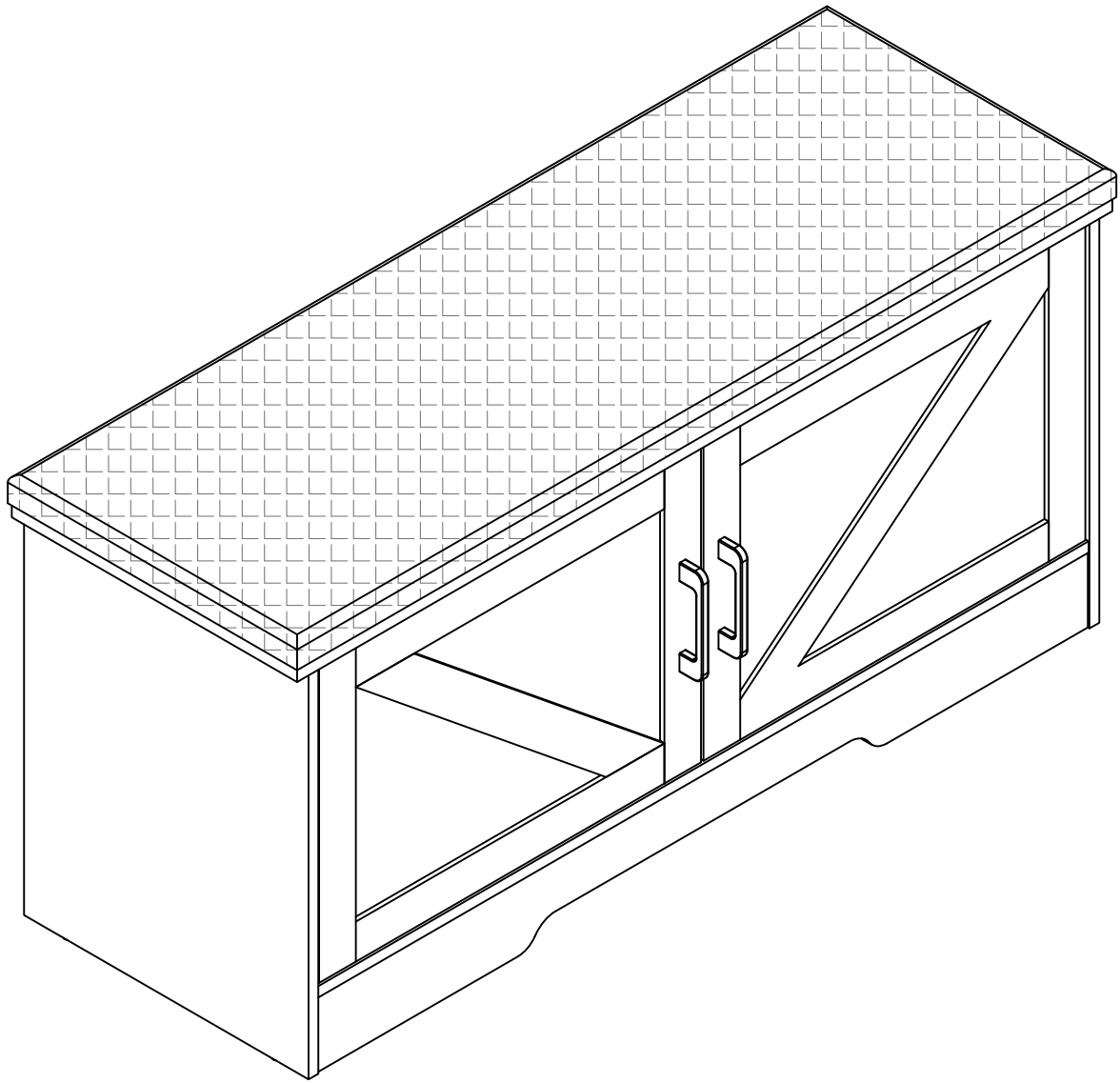

Thank you for choosing this product. We strive to provide you with the best quality products and service in the industry. Should you have any issues, please don't hesitate to contact us.