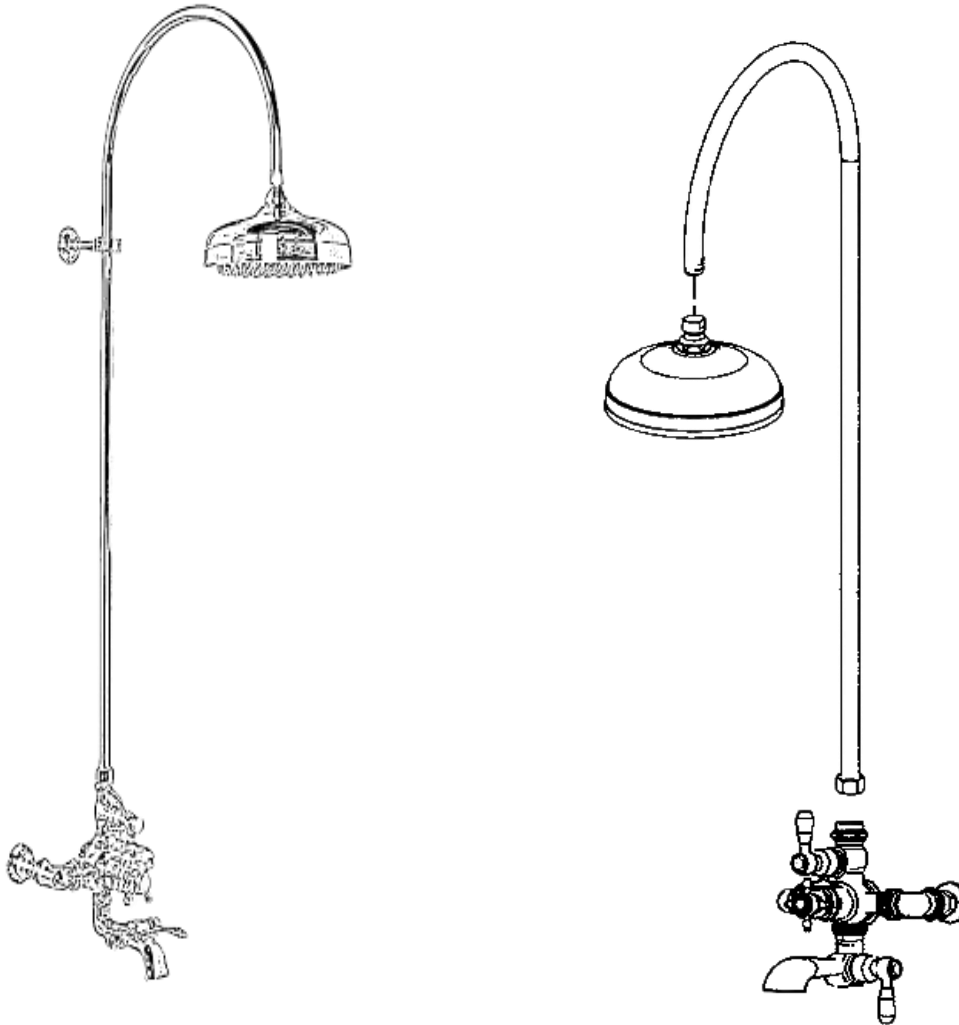

**Exposed Thermostatic Shower System wall Mounted with 1.75 GPM****GUARANTEE & AFTERCARE**

When installing or using tools, take care to avoid damaging the finish or fitting. Clean regularly with a soft damp cloth only to maintain appearance; avoid abrasive cleaners or detergents as they may cause surface damage. The company guarantees against faulty materials or manufacturing, excluding serviceable parts, if installed, cared for, and used according to our instructions.

**WATER SUPPLY REGULATIONS**

This product has been manufactured to comply with the relevant standards and conform to Water Supply Regulations.

COMPONENTS LIST

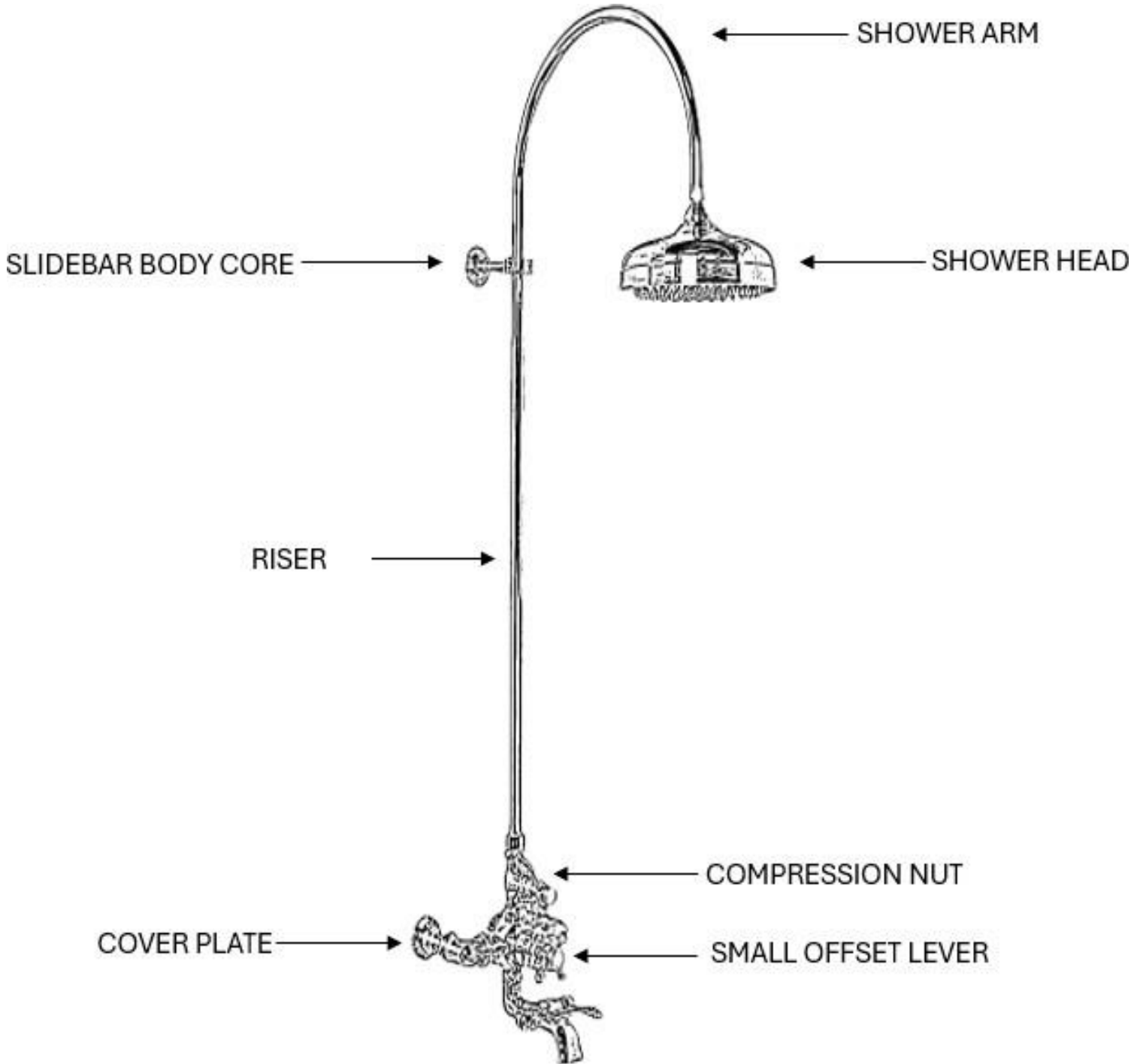

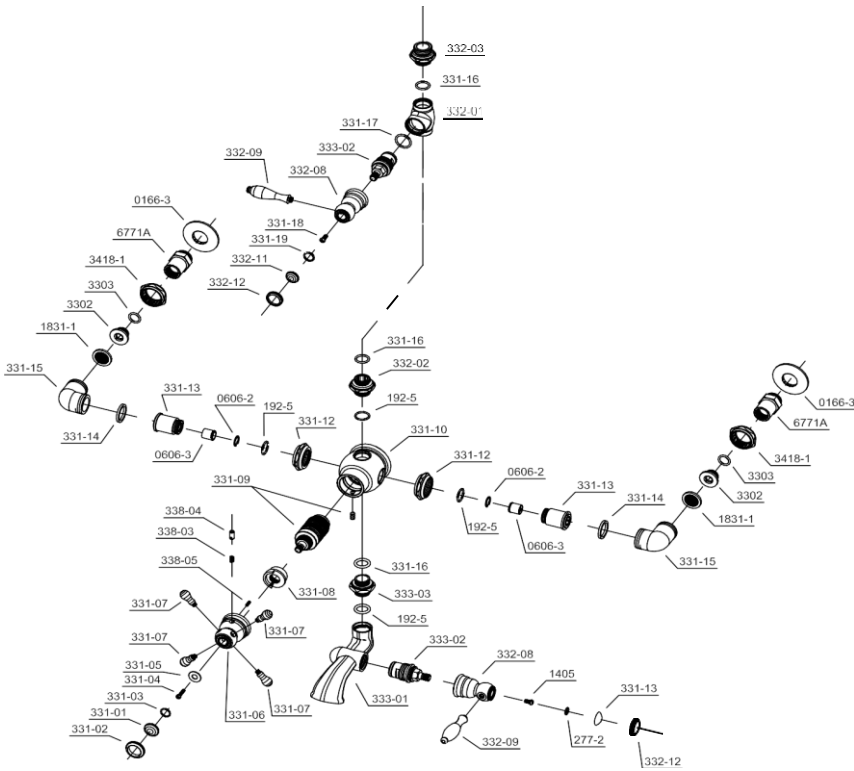

BILL OF MATERIAL				
ITEM	PT/ASSY	DESCRIPTION	TYPE	QTY
1	332-09	Temp control lever	ASSEMBLY	2
2	332-02	Cartridge	ASSEMBLY	2
3	332-03	Spares	ASSEMBLY	2
4	0166-3	Wall Flange	ASSEMBLY	2
5	6771A	Comp nut	ASSEMBLY	2
6	3418-1	Brass Ferule	ASSEMBLY	2
7	331-13	Inlet Bushing	ASSEMBLY	2
8	331-15	D-Elbow	ASSEMBLY	2
9	331-09	Thermostatic Cartridge	ASSEMBLY	2
10	331-07	Handle	ASSEMBLY	4
11	331-04	Screw	ASSEMBLY	1

