





# ASSEMBLY INSTRUCTIONS & PARTS IDENTIFICATION DINING TABLE

Thank you for purchasing this quality product. Be sure to check all packing material carefully for small parts that may have come loose inside the carton during shipment.

Table Components				Table Hardware Kit			
No.	Code	Description	Q'ty	No.	image	Description	Q'ty
1	TBT	TABLE TOP	1 PC	A		BOLT M8*25 MM	8 PCS
2	B	BASE	2 PC	B		BOLT M8*75 MM	2 PCS
				C		FLAT WASHER 25 MM	10 PCS
				D		ALLEN WRENCH 5 MM	1 PC
				E		MOUNTNG PLATE	4 PCS

## STEP 1

ATTACH THE MOUNTING PLATE (E) TO THE LEG ASSEMBLY WITH BOLT (A) AND FLAT WASHER (C). HAND TIGHTEN USING THE ALLEN WRENCH (D).

### PLEASE NOTE:

TWO PERSONS REQUIRED TO SETUP TABLE

LONG BOLT (B) IS USED TO SECURE THE WOOD LEG TO THE TABLE TOP. DO NOT USED THEM TO ATTACH MOUNTING PLATES TO THE TABLE TOP

## STEP 2

PLACE THE TABLE TOP AN A CLEAN PADDED SURFACE TO PREVENT SCRATCHES. ATTACH THE BASE UNIT TO THE TABLE TOP WITH THE BOLTS (A) AND FLAT WASHER. HAND TIGHTEN USING THE ALLEN WRENCH.

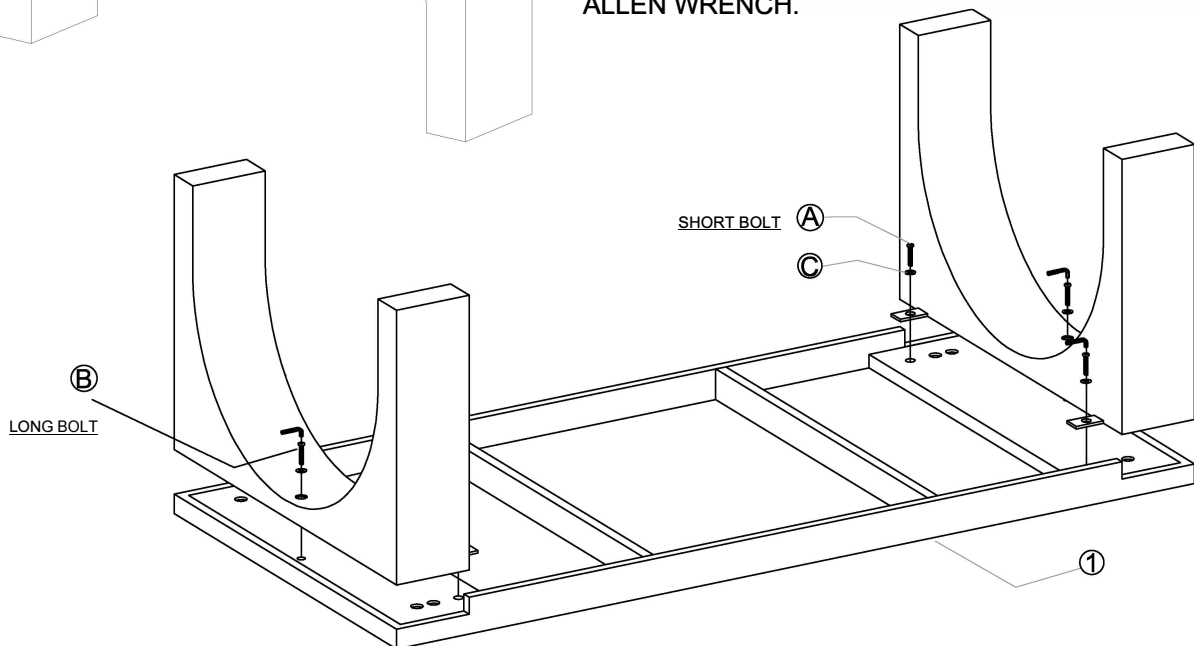
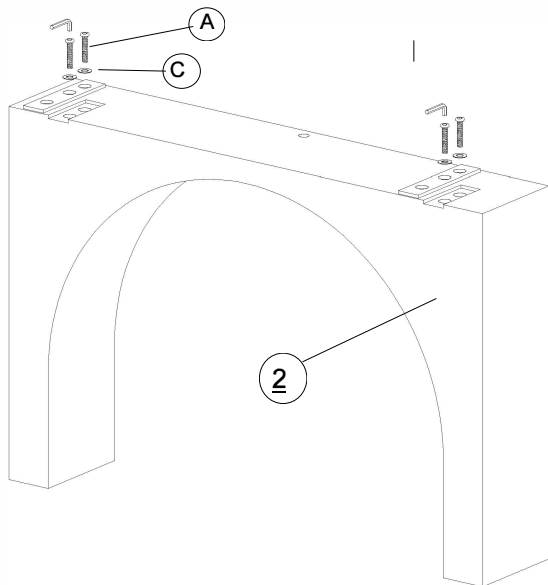

MADE IN INDIA