

# Coffee Table

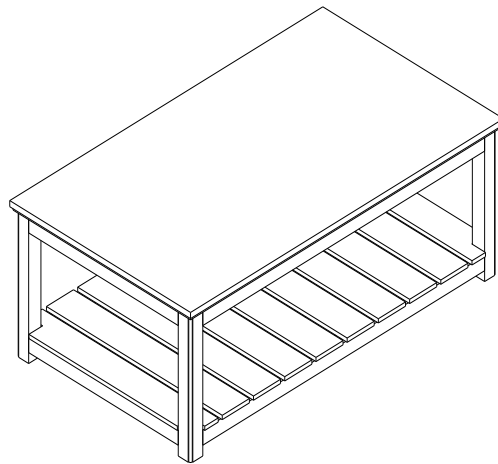





Thank you for purchasing the Coffee Table . We have found it helpful to have a second person present during the assembly process.

---

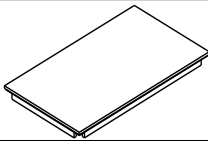
## Coffee Table Assembly Instructions

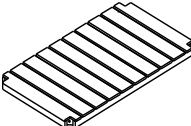
### Parts

NO.	DRAWING	DESCRIPTION	QTY.
A		TOP	1
B		POST	4
C		BOTTOM	1

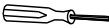
NO.	DRAWING	DESCRIPTION	QTY.
D		M6*45MM BOLT	8
E		WRENCH	1

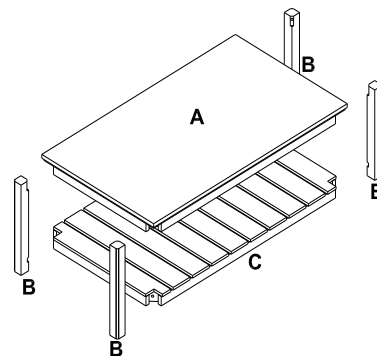

---

### Step 1

Read through these instructions thoroughly before beginning assembly. We have found this to be of great value when assembling this product.

---

## Step 2

Remove all parts and hardware from packing material. Wooden pieces should be placed on a non abrasive surface to prevent damage to the finish.

---

## Step 3

Lay Top (A) upside down on a non abrasive surface. Attach 4 Posts (B) using 4-45MM Hex Bolts (D). **NOTE: Do not tighen firmly at this time.**

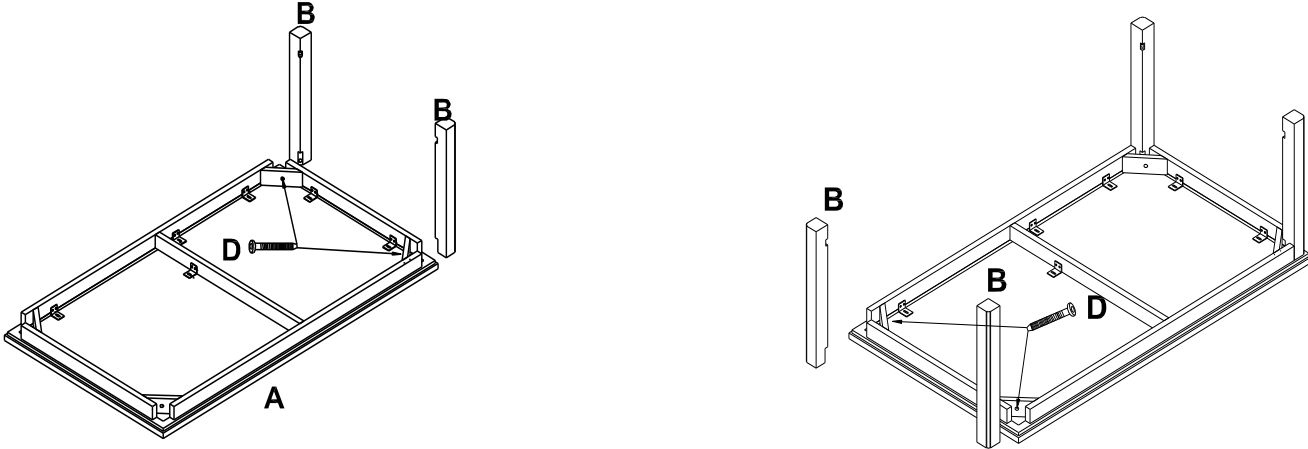

## Step 4

Position Bottom (C) between the legs. Attach Bottom (C) to Post (B) using 4-45MM Hex Bolts (D). **Note: TIGHTEN ALL BOLTS AT THIS TIME!**

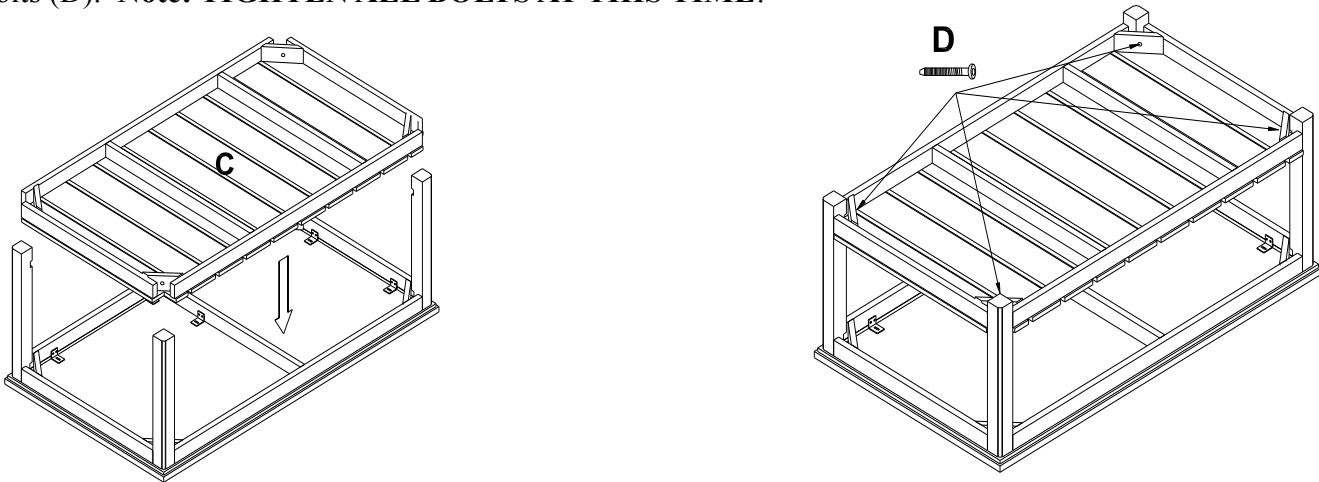

## CARE

Clean with a non abrasive cloth using a mild soap. Make sure to wipe dry.

---