

6 Drawers Dresser
Commode à 6 Tiroirs

THIS INSTRUCTION BOOKLET CONTAINS **IMPORTANT** SAFETY INFORMATION.
PLEASE READ AND KEEP FOR FUTURE REFERENCE.

EN



Before You Start

- ⚠ Please read all instructions carefully.
- ⚠ Retain instructions for future reference.
- ⚠ Separate and count all parts and hardware.
- ⚠ Read through each step carefully and follow the proper order.
- ⚠ We recommend that, where possible, all items are assembled near to the area in which they will be placed in use, to avoid moving the product unnecessarily once assembled.
- ⚠ Always place the product on a flat, steady and stable surface.
- ⚠ Keep all small parts and packaging materials for this product away from babies and children as they potentially pose a serious choking hazard.

FR







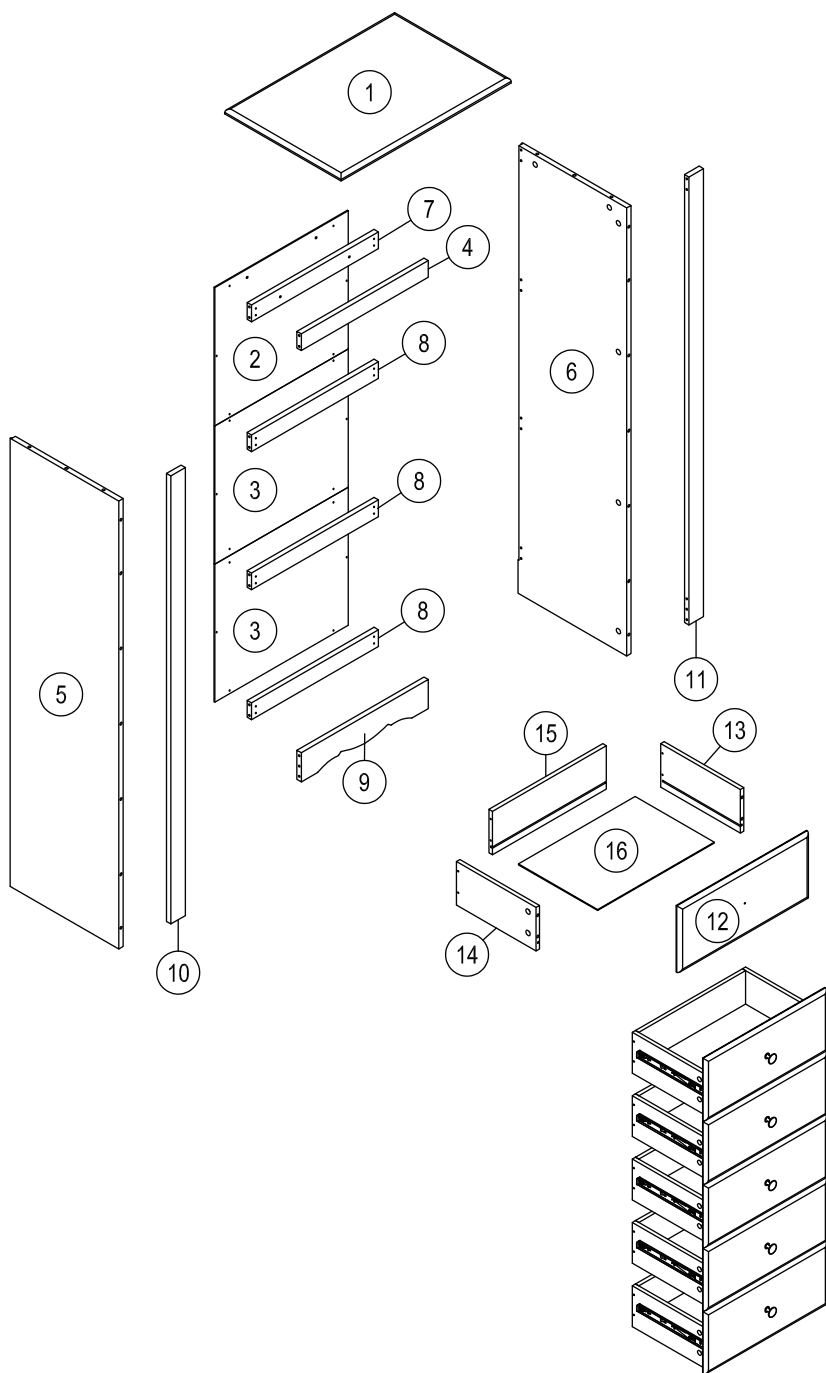



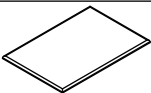
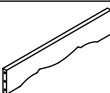

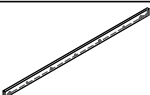

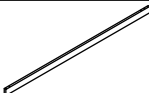
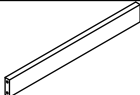
Avant de Commencer

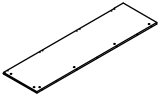

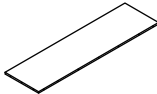

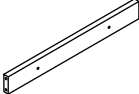

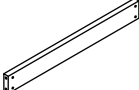
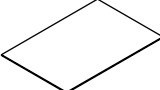

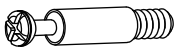

- ⚠ Veuillez lire attentivement toutes les instructions.
- ⚠ Conservez les instructions pour vous y référer ultérieurement.
- ⚠ Vérifiez toutes les pièces et les accessoires.
- ⚠ Lisez attentivement chaque étape et suivez l'ordre correct.
- ⚠ Nous recommandons que, dans la mesure du possible, tous les produits soient assemblés à proximité de la zone où ils seront utilisés, afin d'éviter tout déplacement inutile du produit une fois assemblé.
- ⚠ Placez toujours le produit sur une surface plane et stable.
- ⚠ Conservez toutes les petites pièces de ce produit et les matériaux d'emballage hors de portée des bébés et des enfants, car ils pourraient présenter un risque d'étouffement.



PARTS LIST /LISTE DES PIÈCES

①		X1	⑨		X1
②		X1	⑩		X1
③		X2	⑪		X1
④		X1	⑫		X6
⑤		X1	⑬		X6
⑥		X1	⑭		X6
⑦		X1	⑮		X6
⑧		X3	⑯		X6

HARDWARE LIST /LISTE DES ACCESSOIRES

Ⓐ	 6*35mm	X36	Ⓕ	 4*60mm	X24
Ⓑ	 15*10mm	X36	Ⓖ	 5*50mm	X2
Ⓒ	 6*20mm	X34	Ⓗ	 6*20mm	X6
Ⓓ	 3.5*12mm	X48	Ⓖ	 3.5*15mm	X18
Ⓔ	 3.5*12mm	X24	Ⓙ		X12

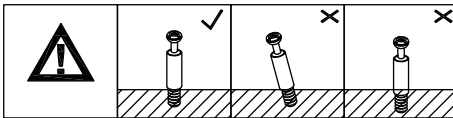
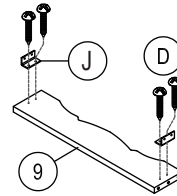
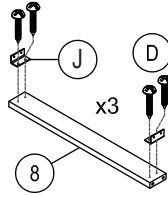
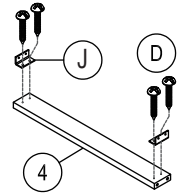
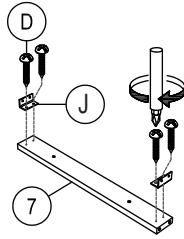
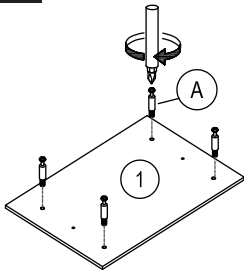
1

(A)		X4
(D)		X24
(J)		X12

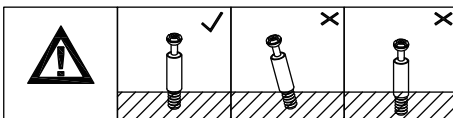
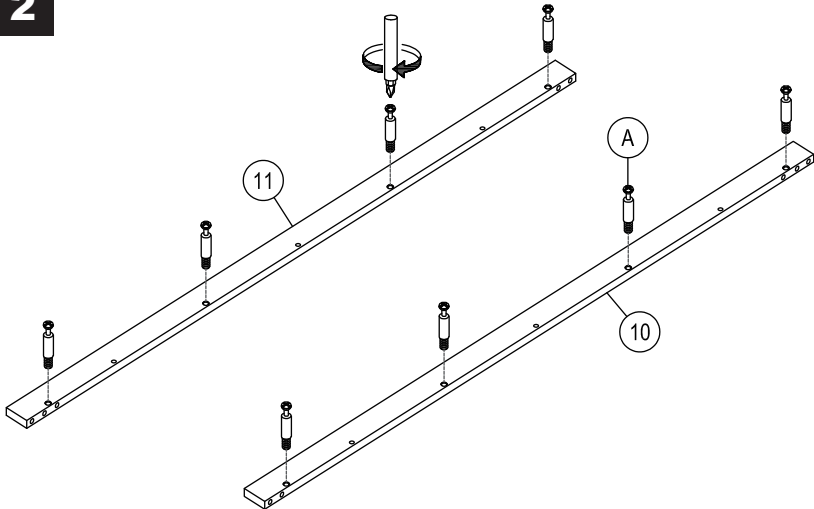
2

(A)		X8
-----	--	----

3

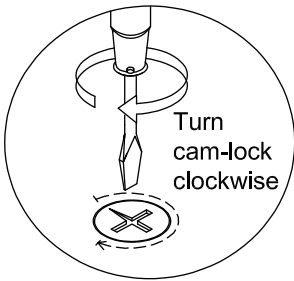
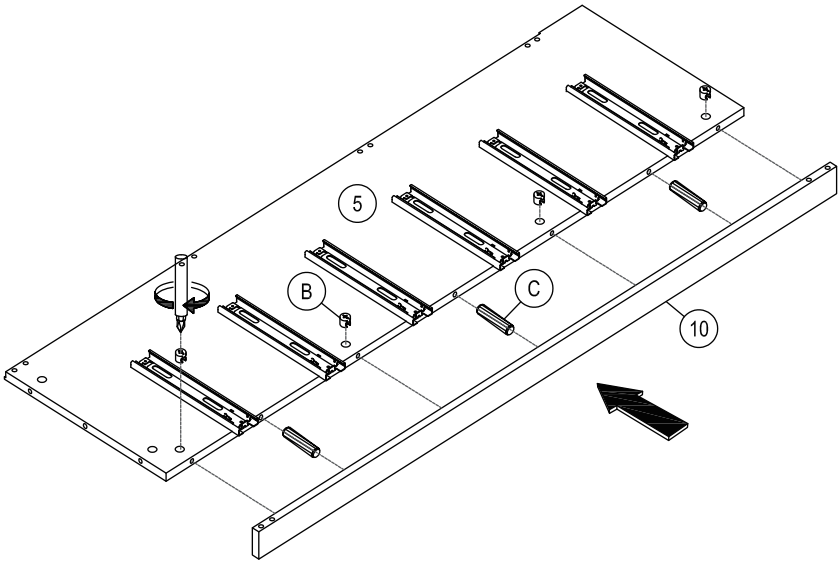

Turn
cam-lock
clockwise

Turn cam-lock clockwise
/Tournez le verrou à came dans le sens
des aiguilles d'une montre

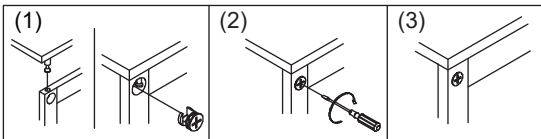

(B)		X4
(C)		X3

4

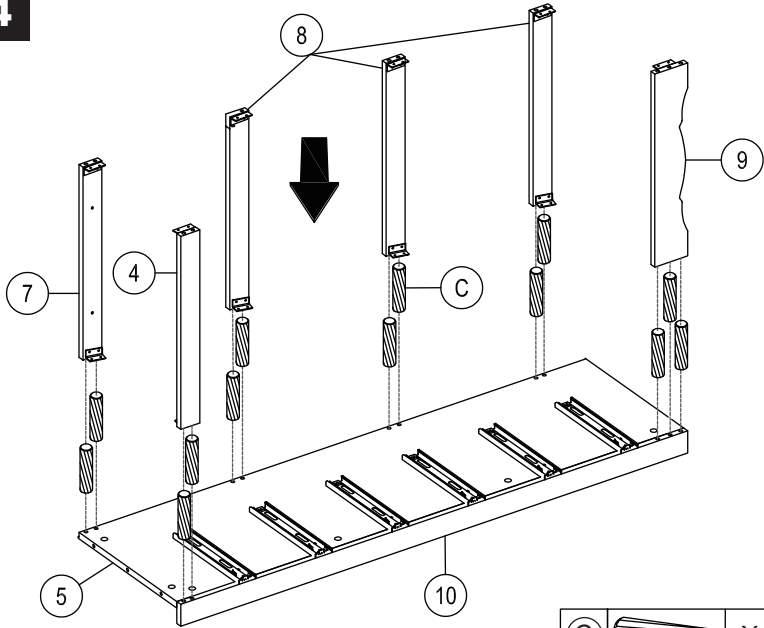

5

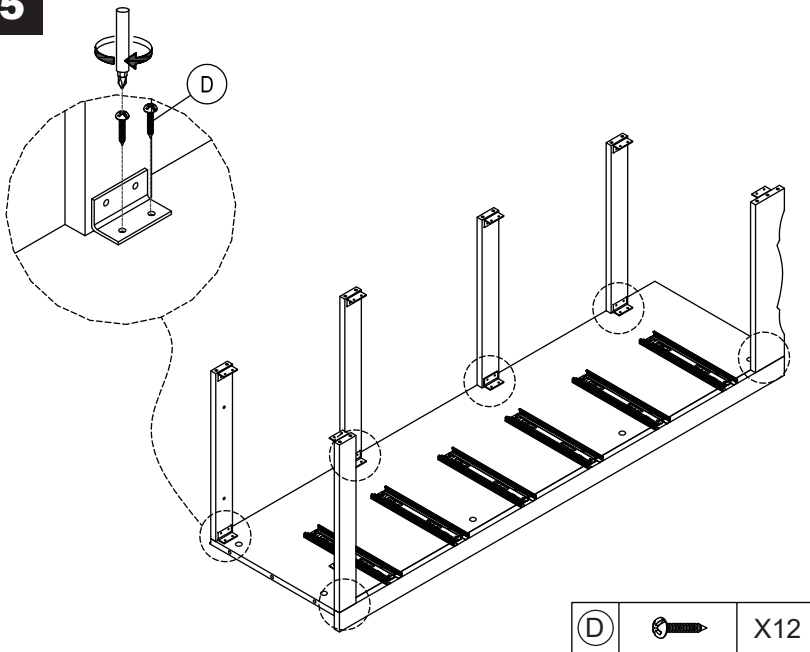

6

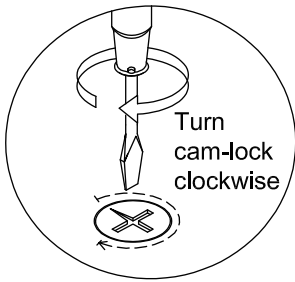
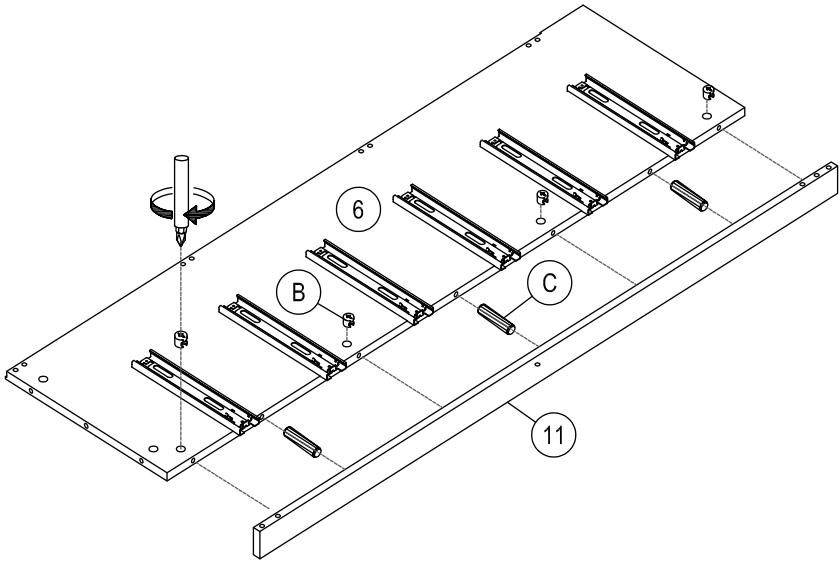

Turn
cam-lock
clockwise

Turn cam-lock clockwise
/Tournez le verrou à came dans le sens
des aiguilles d'une montre

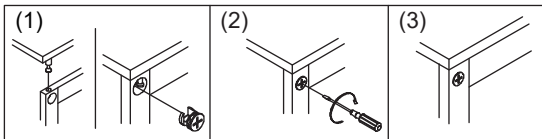

(B)		X4
(C)		X3

7

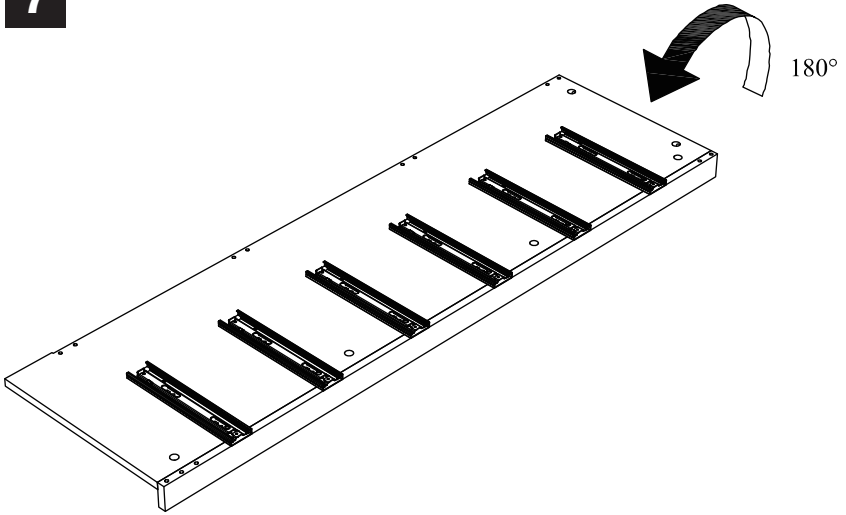

8

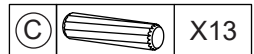
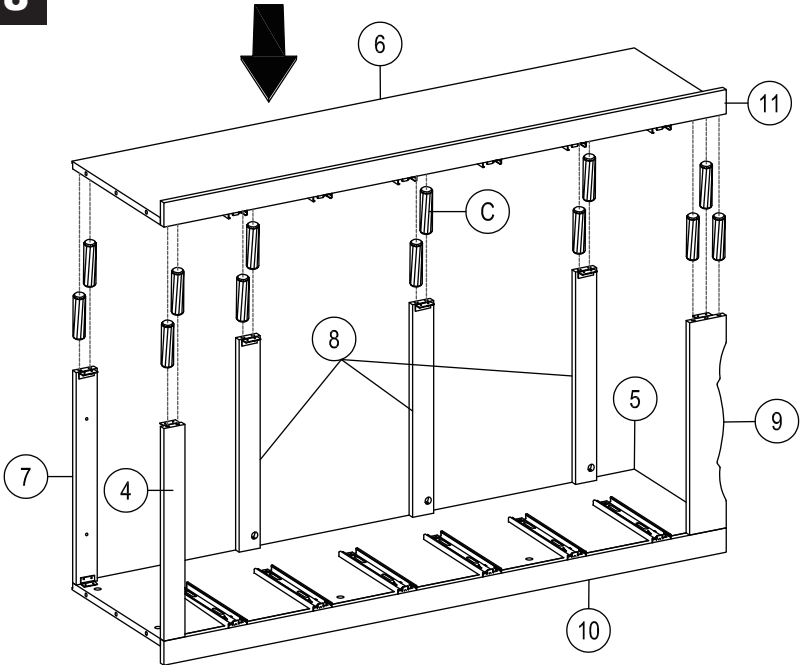

9

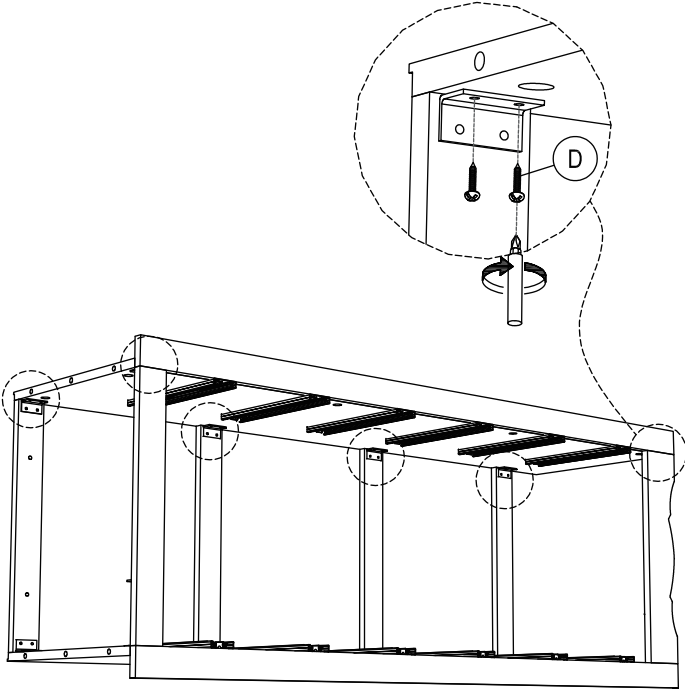

10

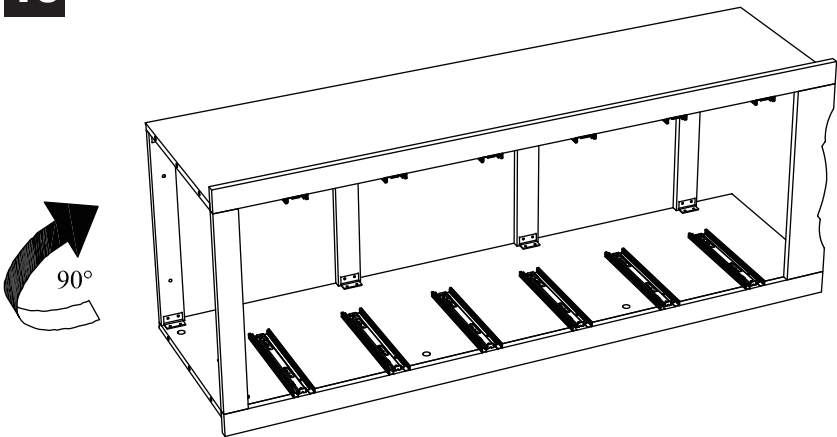

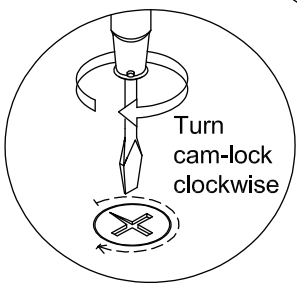
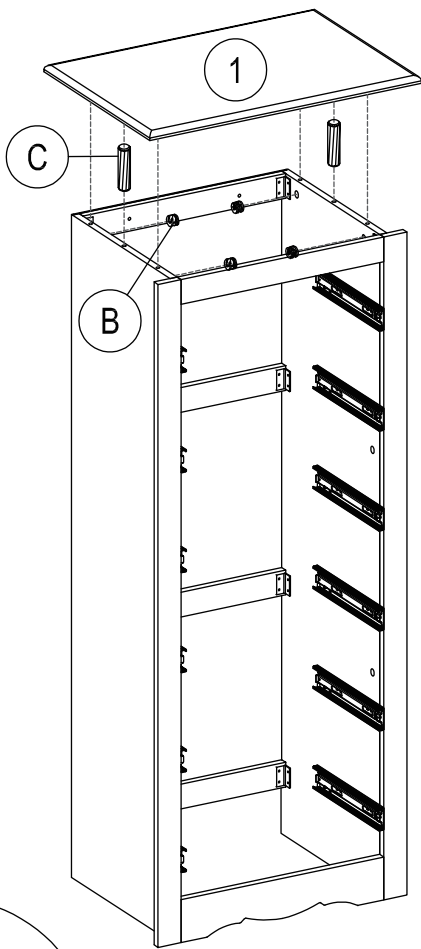

Turn cam-lock clockwise

Turn cam-lock clockwise / Tournez le verrou à came dans le sens des aiguilles d'une montre

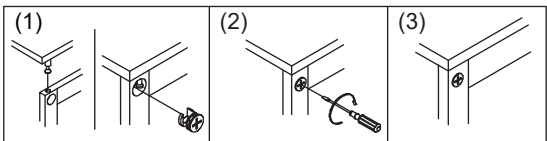

(B)		X4
(C)		X2

12

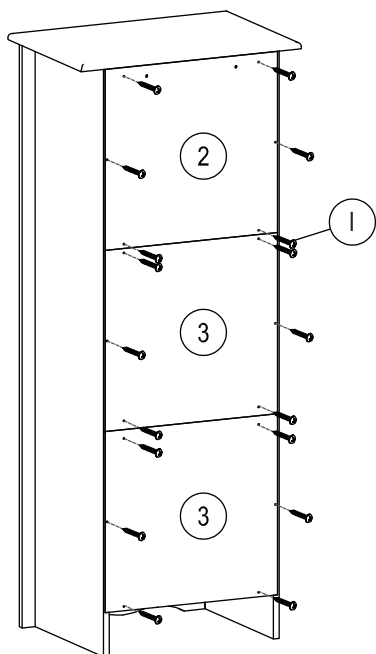

①		X18
---	---	-----

13 X6

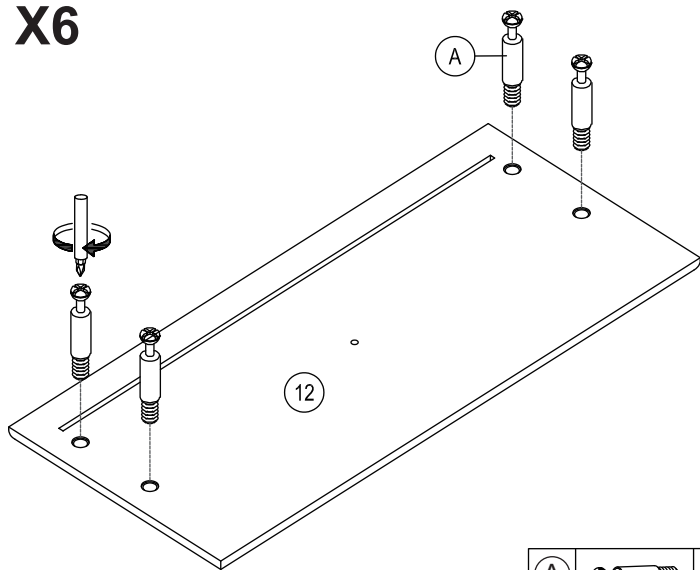

Ⓐ		X24
---	---	-----

14 X6

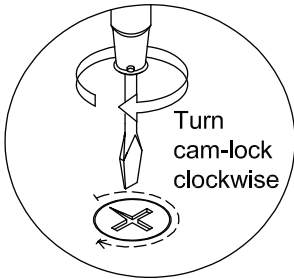
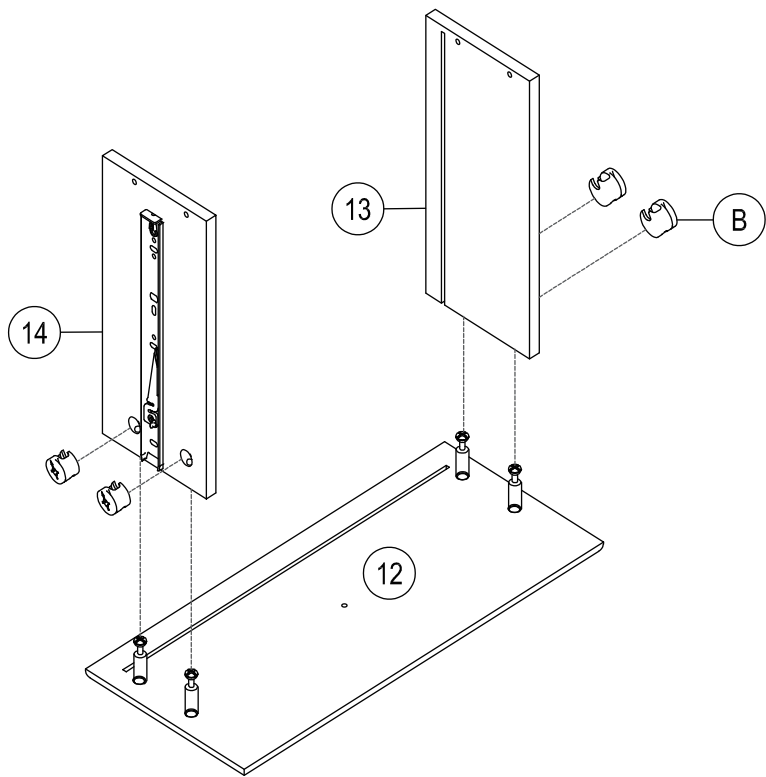

Turn cam-lock clockwise
/Tournez le verrou à came dans le sens des aiguilles d'une montre

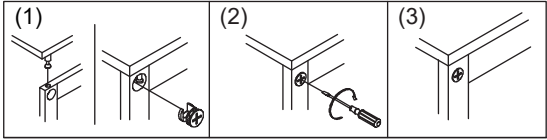

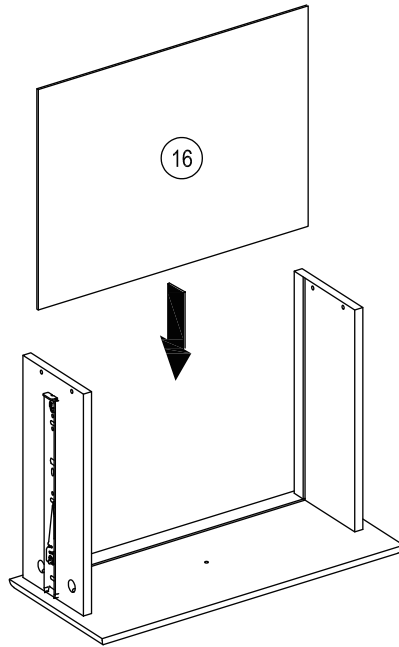

(B)		X24
-----	--	-----

15 X6

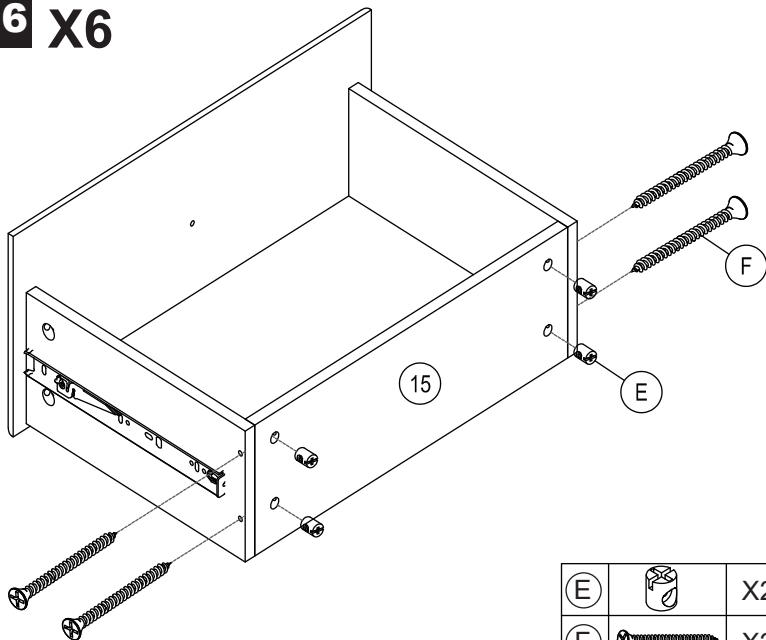

16 X6



(E)		X24
(F)		X24

17 X6

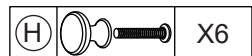
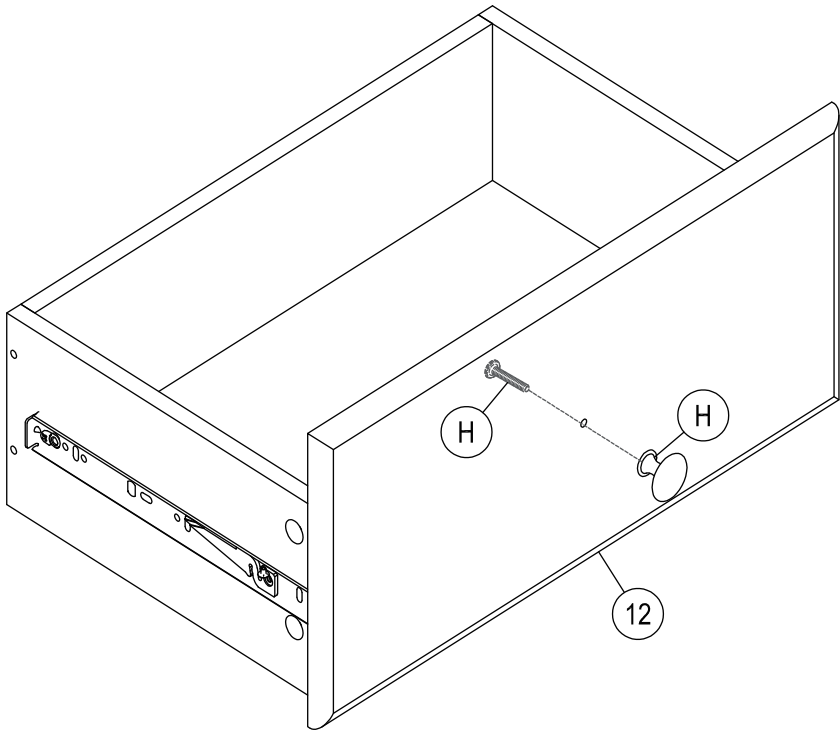

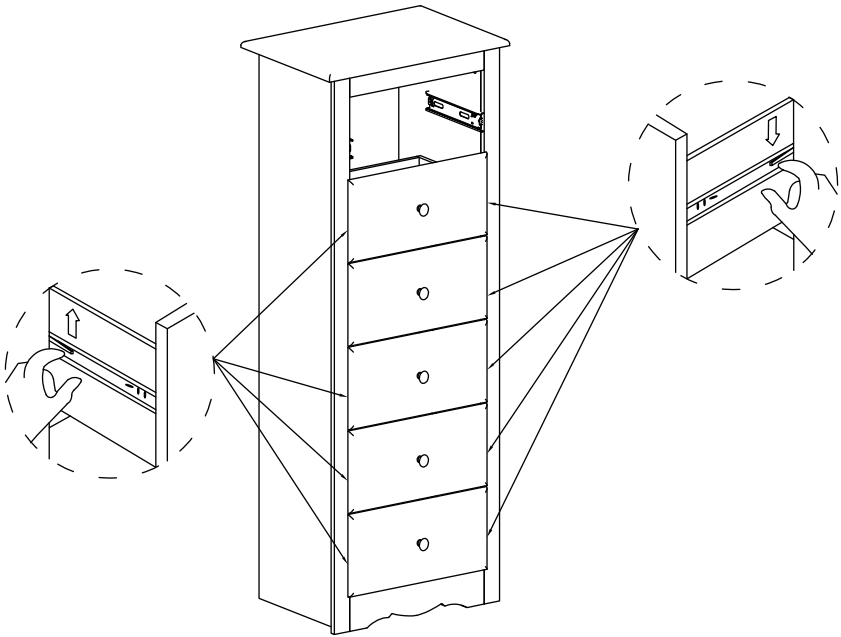

These slide sections mounted on the cabinet must be fully extended for installation.
/Ces sections coulissantes montées sur l'armoire doivent être entièrement déployées pour l'installation.

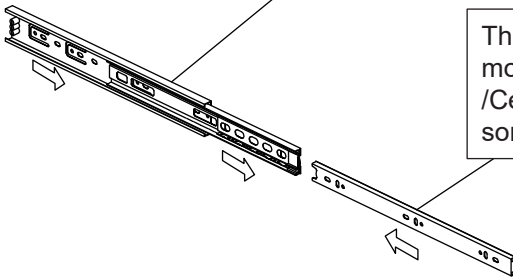

These slide sections are mounted to the drawer.
/Ces sections coulissantes sont montées sur le tiroir.

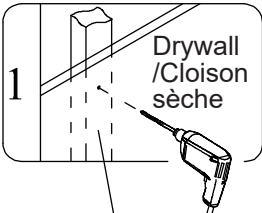
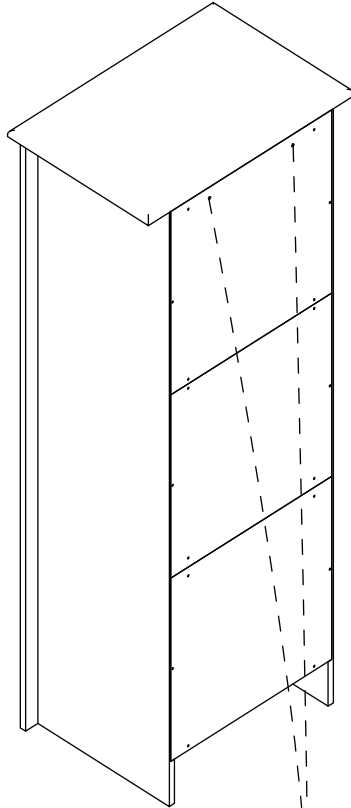

Drill a hole.
/Percez un trou.

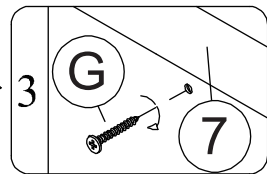
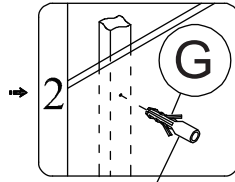

Insert the plastic anchor into the hole,
then insert the screw into the anchor.
/Insérez la cheville en plastique dans le trou,
puis insérez la vis dans la cheville.

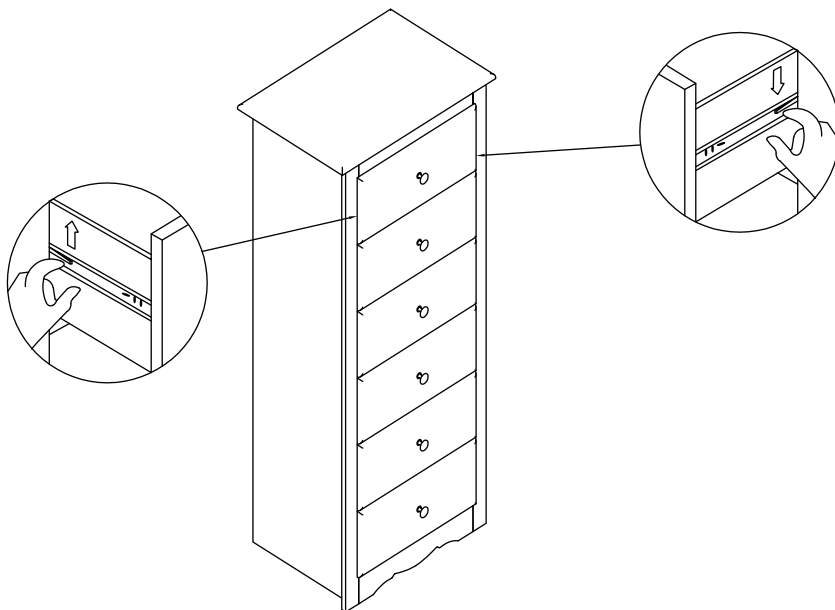

These slide sections mounted on the cabinet must be fully extended for installation.
/Ces sections coulissantes montées sur l'armoire doivent être entièrement déployées pour l'installation.

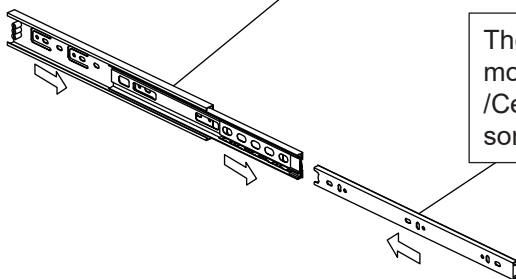

These slide sections are mounted to the drawer.
/Ces sections coulissantes sont montées sur le tiroir.



Return / Damage Claim Instructions

- ⚠ **DO NOT discard the box / original packaging.**
In case a return is required, the item must be returned in original box. Without this your return will not be accepted.
- ⚠ **Take a photo of the box markings.**
A photo of the markings (text) on the side of the box is required in case a part is needed for replacement. This helps our staff identify your product number to ensure you receive the correct parts.
- ⚠ **Take a photo of the damaged part (if applicable).**
A photo of the damage is always required to file a claim and get your replacement or refund processed quickly. Please make sure you have the box even if it is damaged.
- ⚠ **Send us an email with the images requested.**
Email us directly from marketplace where your item was purchased with the attached images and a description of your claim.



Instructions De Retour / Réclamation De Dommages

- ⚠ **NE PAS jeter la boîte/l'emballage d'origine.**
Dans le cas où un retour est requis, l'article doit être retourné dans sa boîte d'origine. Sans cela, votre retour ne sera pas accepté.
- ⚠ **Prenez une photo des marquages de la boîte.**
Une photo des marquages (texte) sur le côté de la boîte est requise au cas où une pièce serait nécessaire pour le remplacement. Cela aide notre personnel à identifier votre numéro de produit pour s'assurer que vous recevez les bonnes pièces.
- ⚠ **Prenez une photo des dommages (le cas échéant).**
Une photo des dommages est toujours requise pour déposer une réclamation et obtenir rapidement votre remplacement ou votre remboursement. Assurez-vous d'avoir la boîte même si elle est endommagée.
- ⚠ **Envoyez-nous un e-mail avec les images demandées.**
Envoyez-nous un e-mail directement depuis le marché où votre article a été acheté avec les images ci-jointes et une description de votre réclamation.