

ASSEMBLY INSTRUCTION

NOTES:

- Do not skip any step.
- Do not fully tight screws until all the bed parts are assembled.

WARNING:

- WARNIND FOR YOUNG CHILDREN**-This product contains small components,please ensure that they are kept away from small children while assembling.

Warranty Information:

- We warranty this product to be free from defects in materials.This warranty covers one year from the date of original purchase.

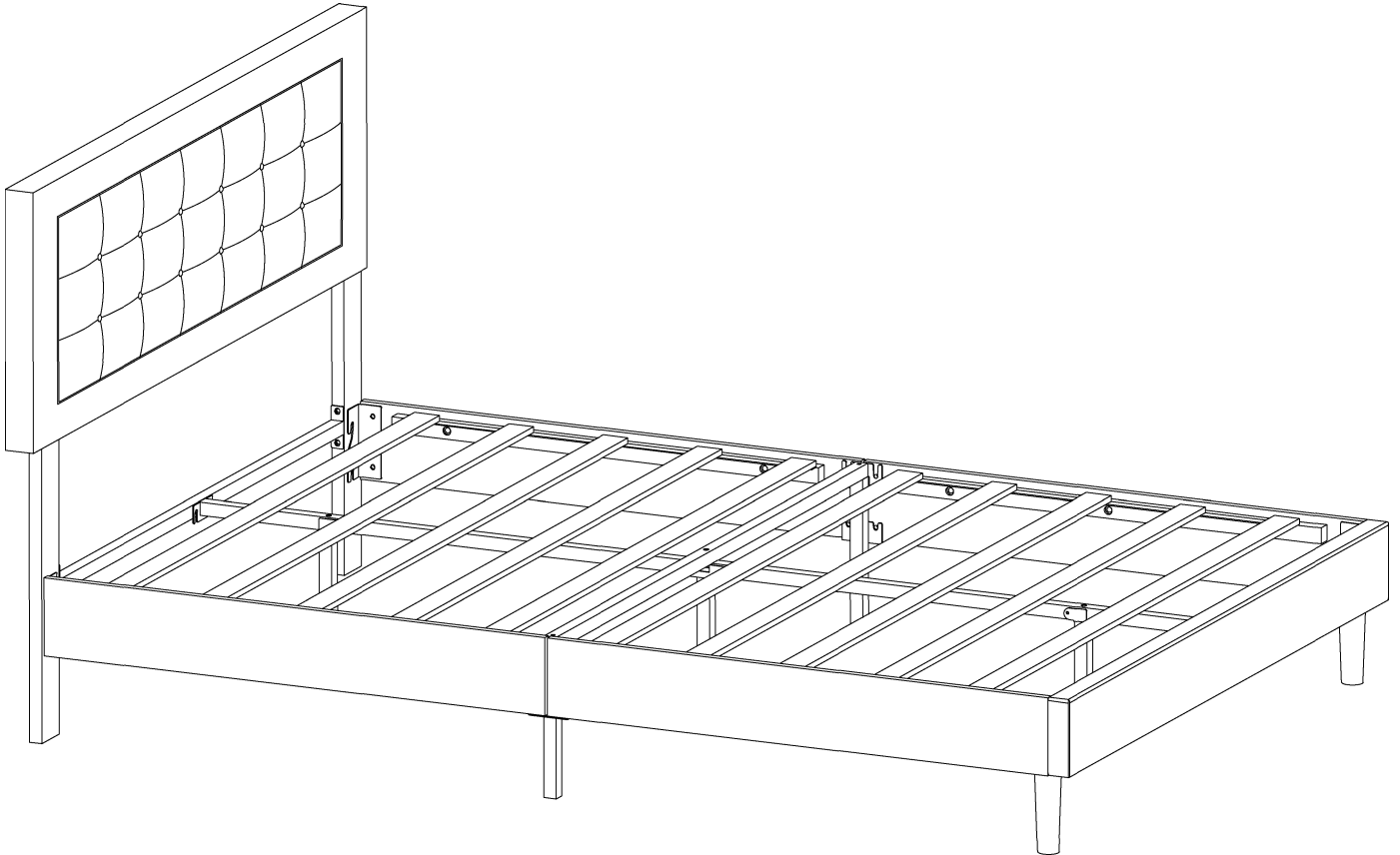

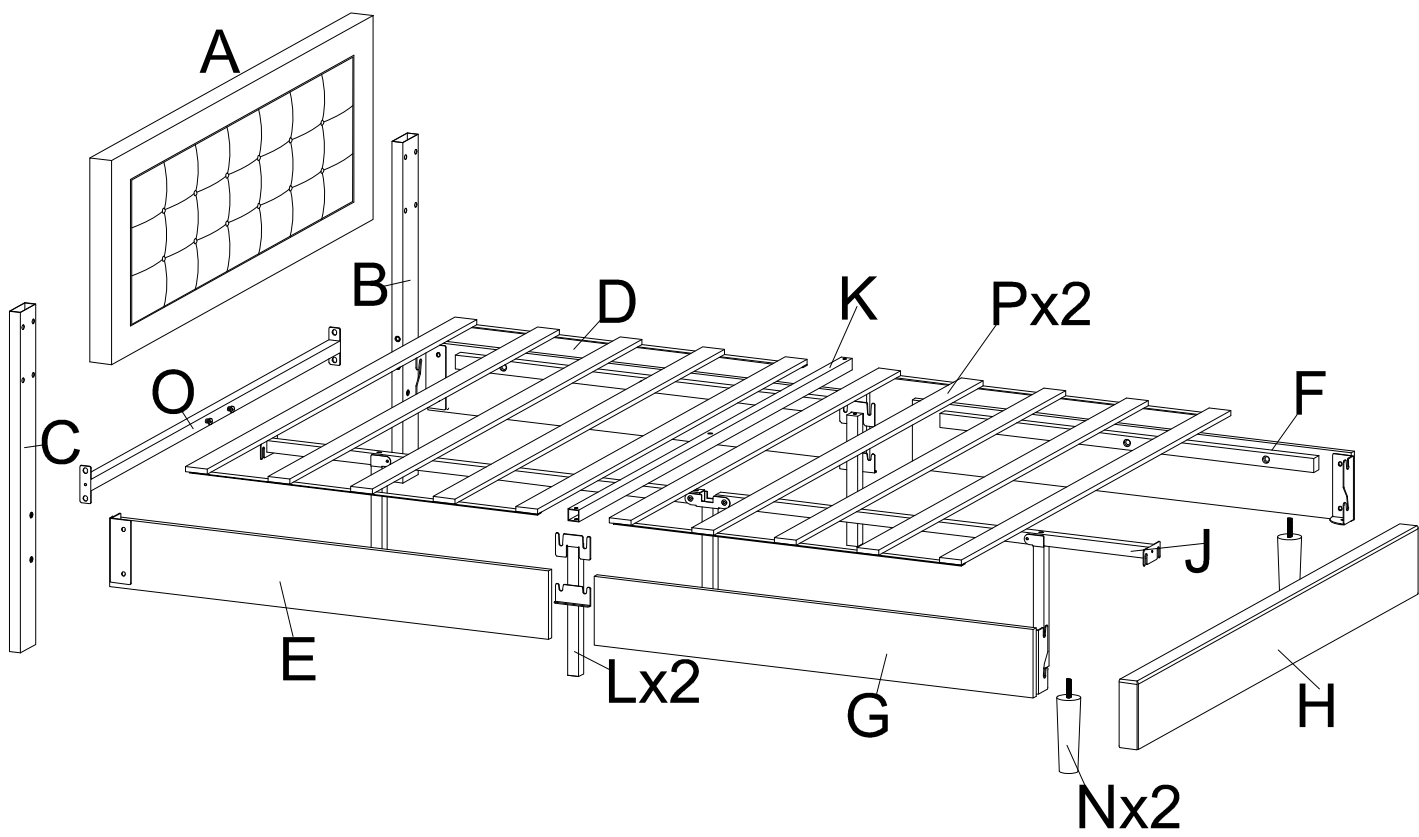

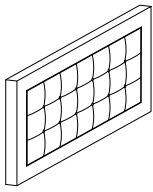
A

1PC

B

Comes with two (ff) screws



1PC

C

Comes with two (ff) screws



1PC

D

Comes with two (ff) screws

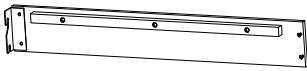

1PC

E

Comes with two (ff) screws



1PC

F

Comes with two (ff) screws



1PC

G

Comes with two (ff) screws

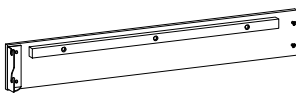

1PC

H

Comes with four (gg) screws

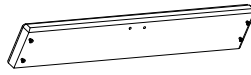

1PC

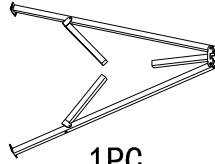
J

1PC

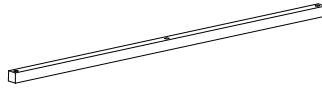
K

1PC

L

2PCS

N

2PCS

O

Comes with two (ff) screws

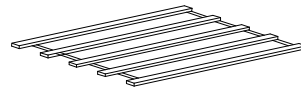

1PC

P

2PCS

aa

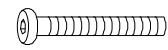

M8x50

1

bb

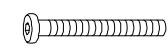

M8x40

10

dd

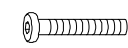

M6x35

2

ee



5mm

1

ff



M8x15

4

gg



M8x25

2

ii



1

SPARE

aa



1

bb

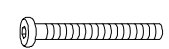

1

dd

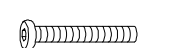

1

gg

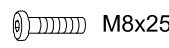

Screws on the board

2



ff



Screws on the board



3

Step 1

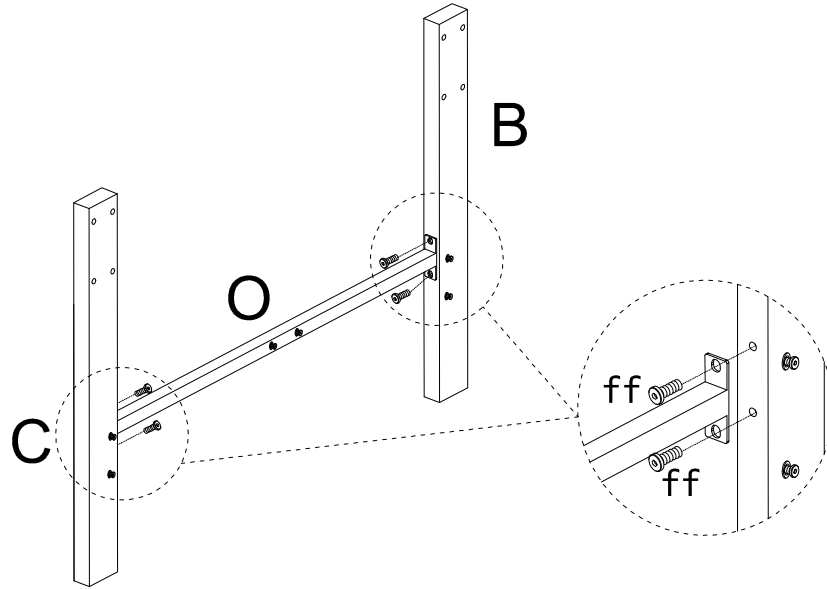
ff		M8x15	4
ee		5mm	1



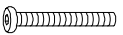

Step 2

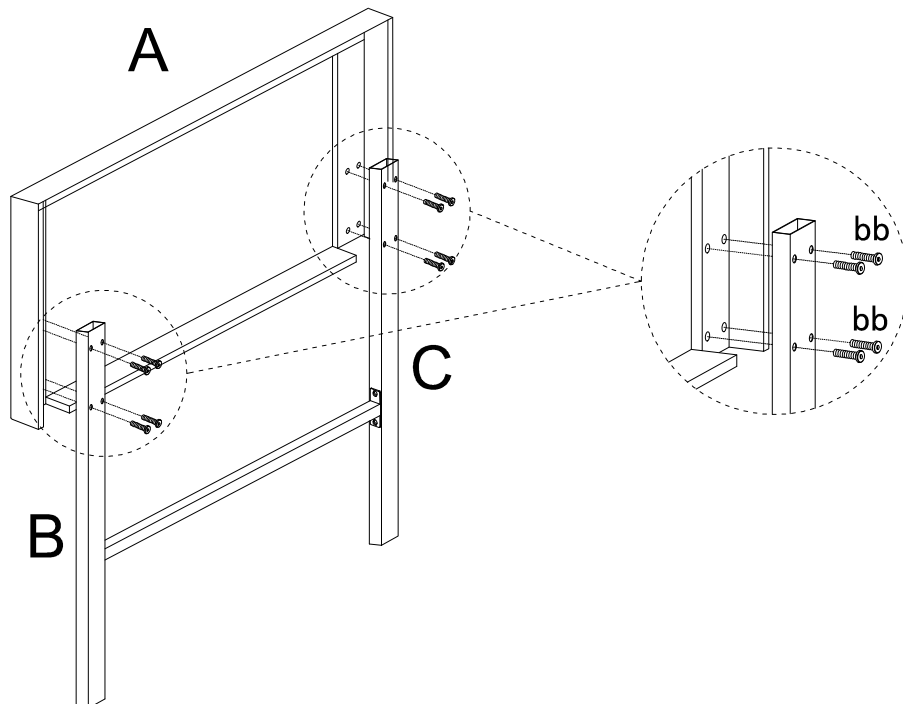
bb		M8x40	8
ee		5mm	1



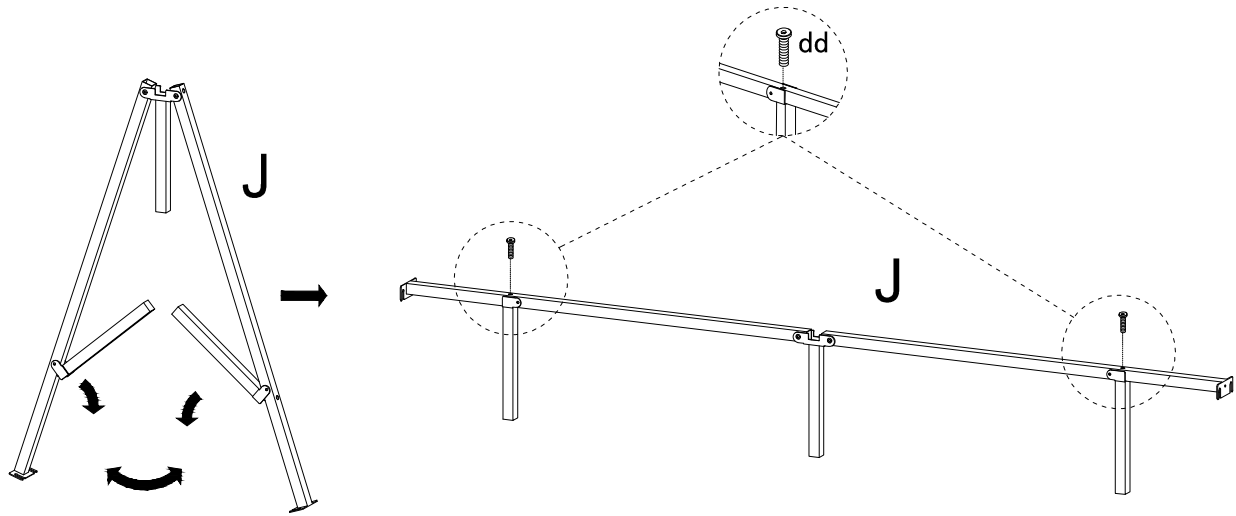

Step 3

dd		M6x35	2
ee		5mm	1



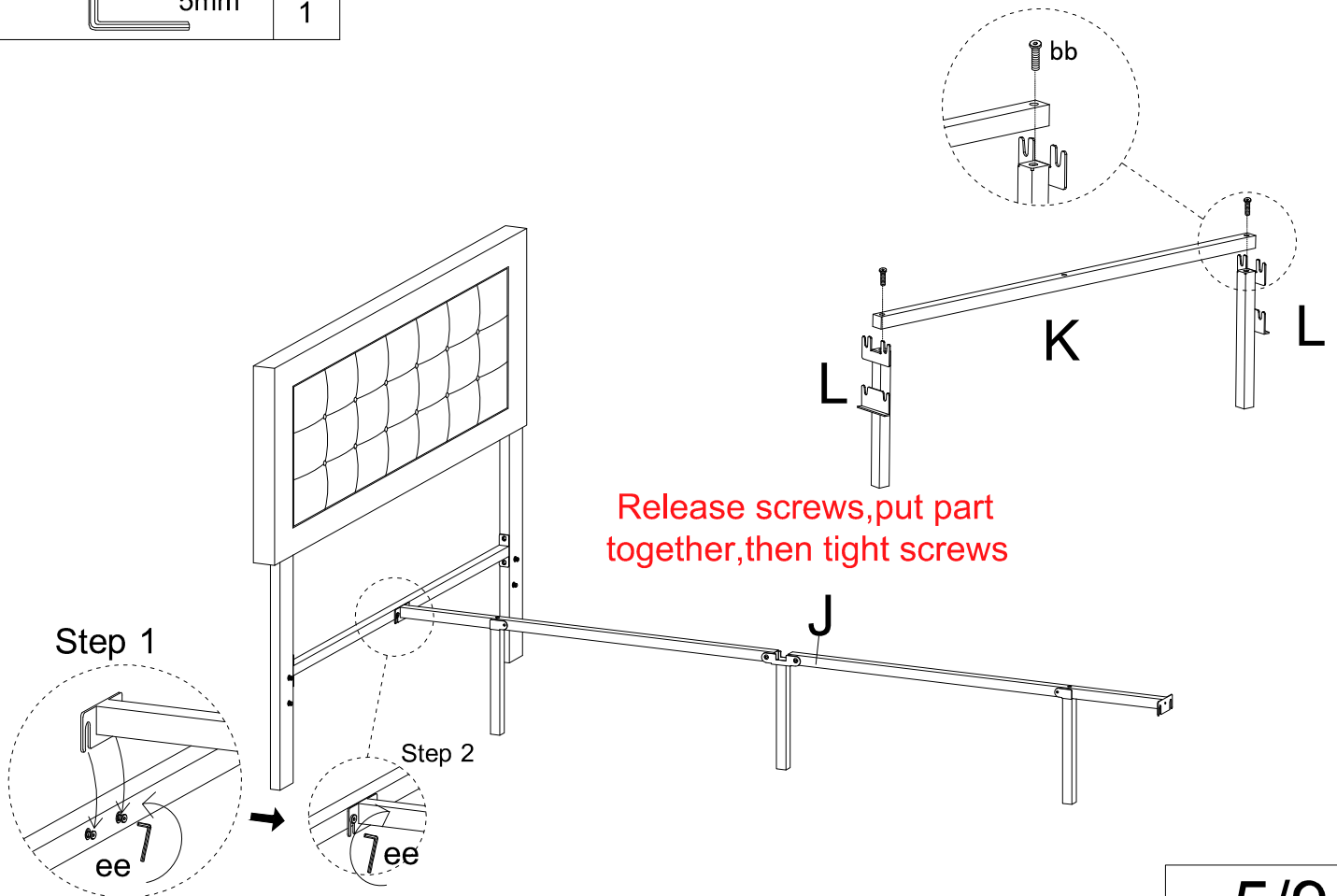

Step 4

bb		M8x40	2
ee		5mm	1

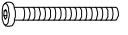

Step 5

aa		M8x50	1
ee		5mm	1

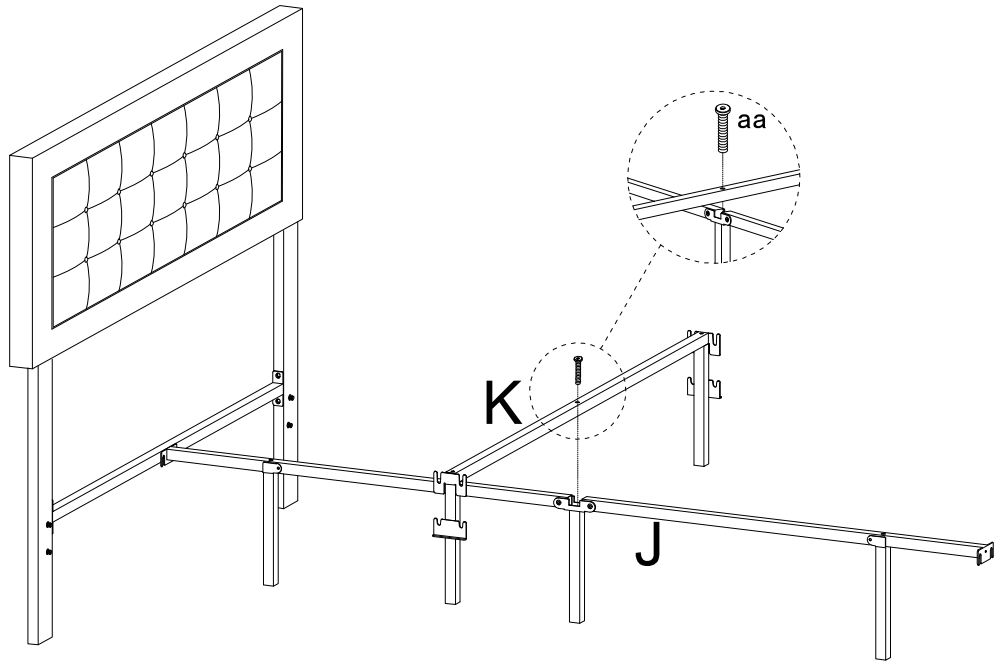

Step 6

ee		5mm	1
----	---	-----	---

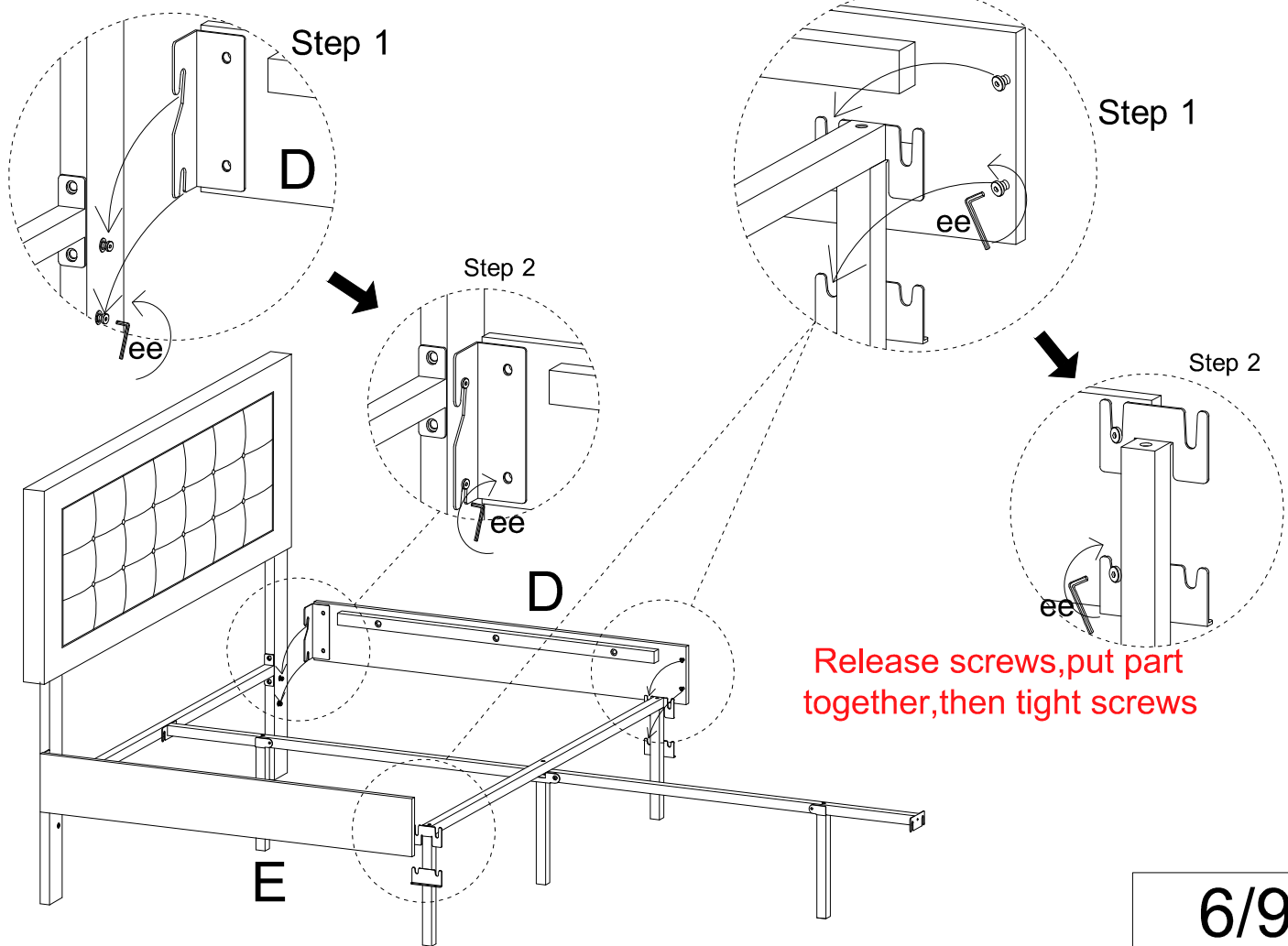

ee 5mm 1

Step 7

Step 1

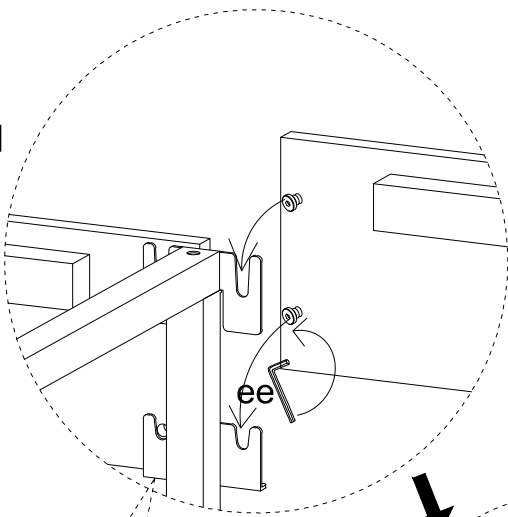

Step 2

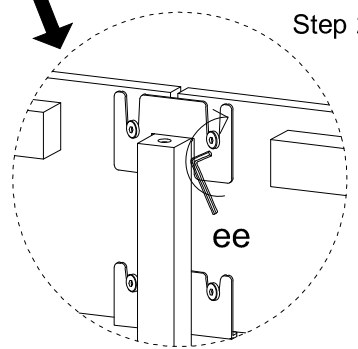

Release screws, put part together, then tight screws

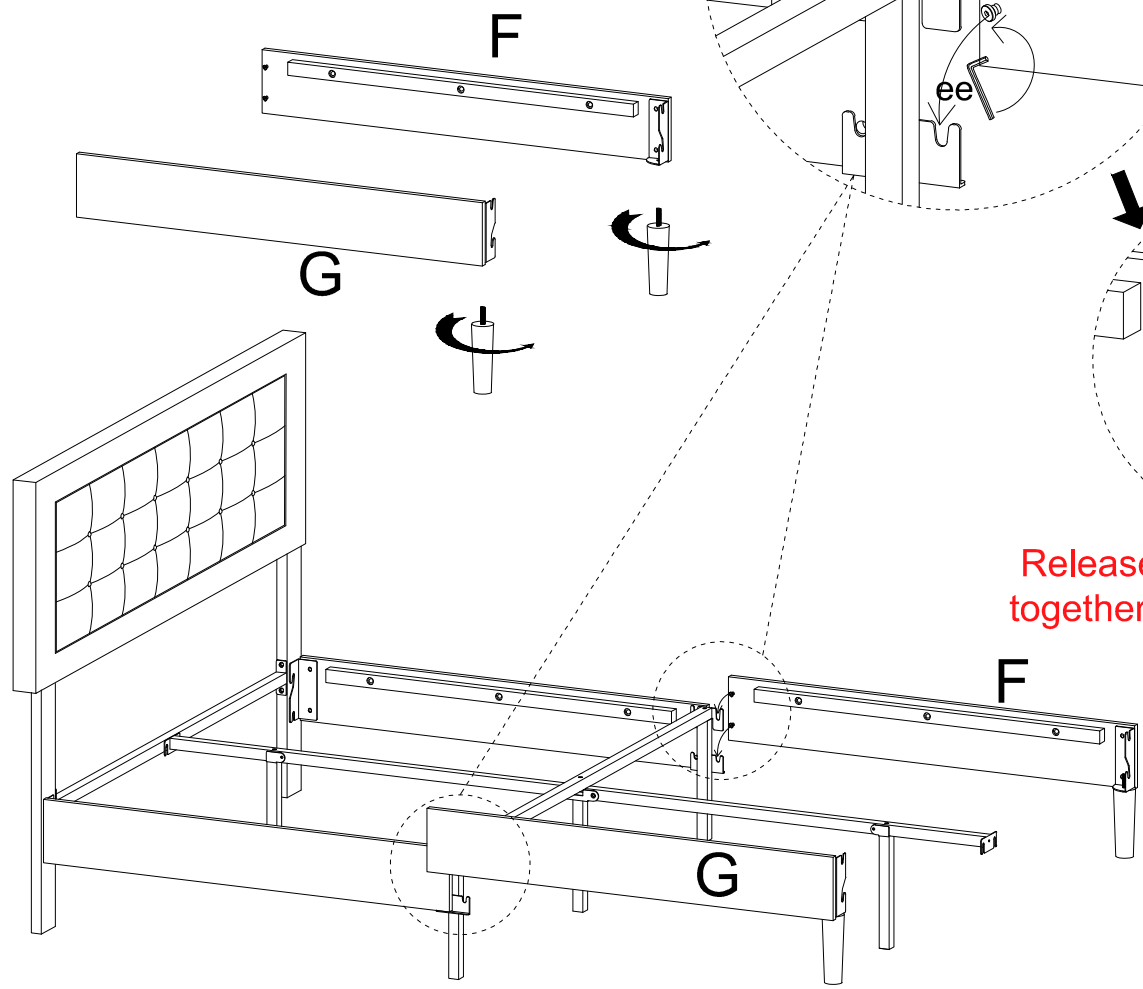

ee 5mm 1

Step 8

Step 1

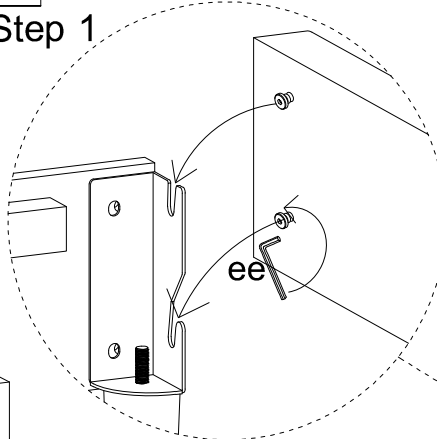

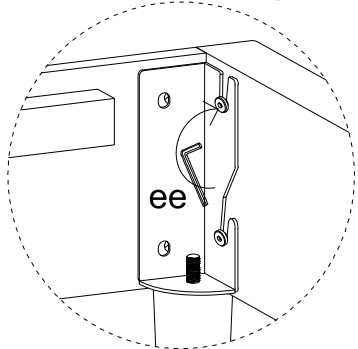

Step 2

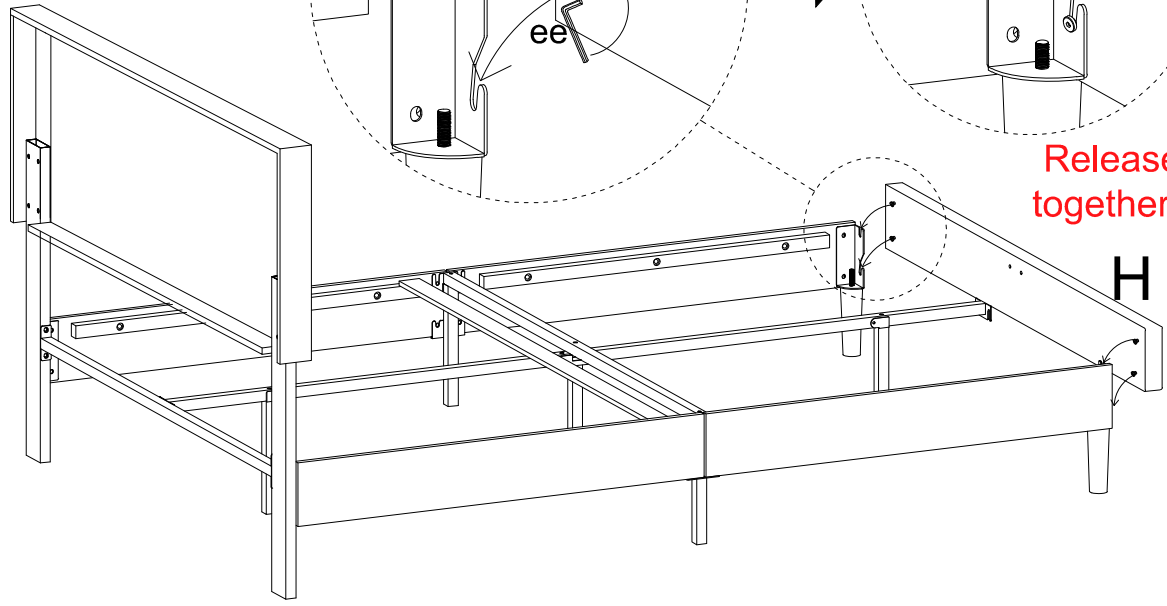

Release screws, put part together, then tight screws



gg		M8x25	2	ee		5mm	1
ii			1				

Step 9

1. Tighten screw gg

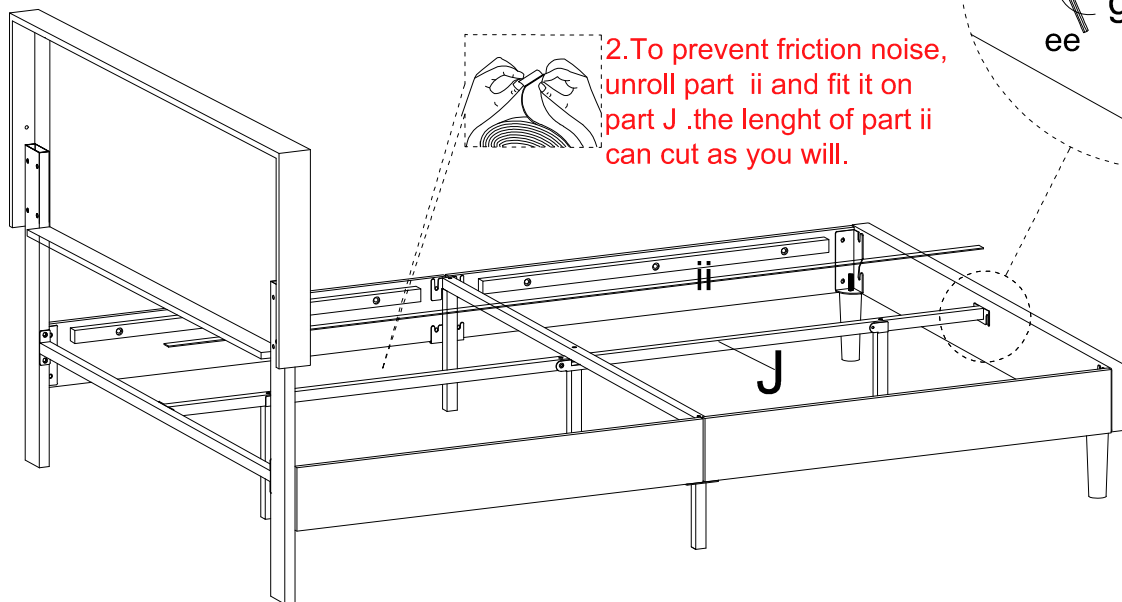
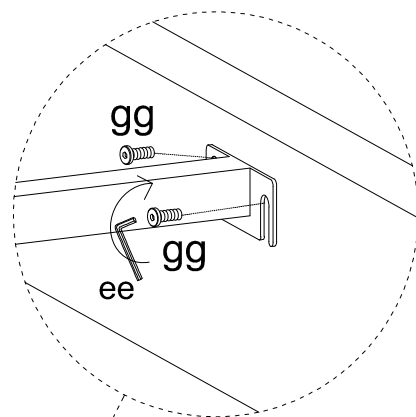

2. To prevent friction noise, unroll part ii and fit it on part J. the length of part ii can cut as you will.

Step 10

