

# **Thank you for your purchasing !**

**If you have any issues with your order regarding**

- ⚠ Damaged Packaging**
- ⚠ Missing parts**
- ⚠ Material and workmanship defect**
- ⚠ Installation issues**

**Please contact us.**

**We will deal with the issues within 24 hours .**

We hope you have a great shopping experience.

## Armrest Module

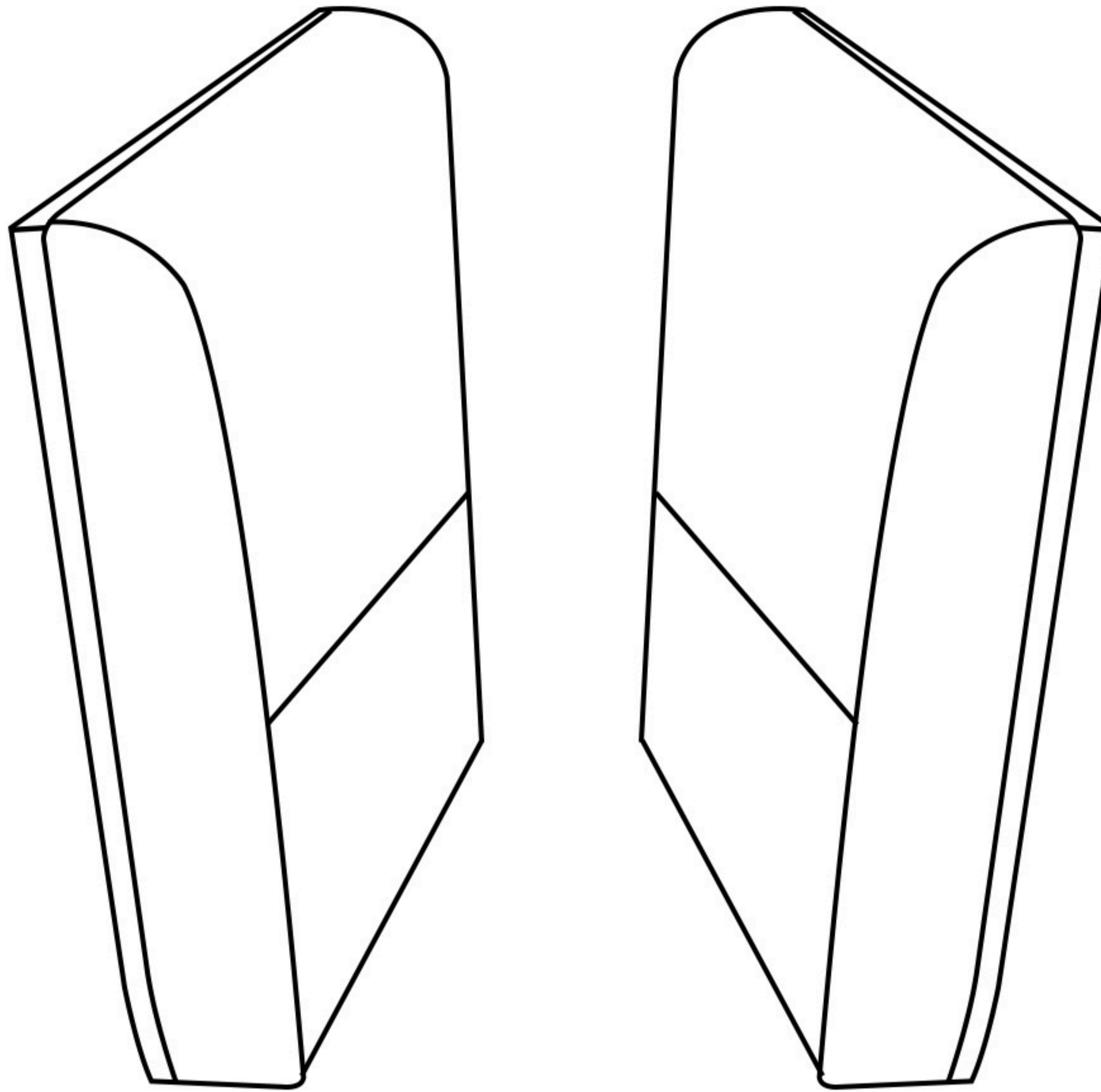

## Parts List (Checking the part lists when you get the packing)



M6 Allen Key x1

**A**

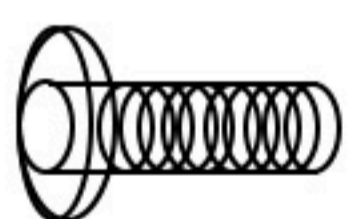

M6 Bolt x8

**B**

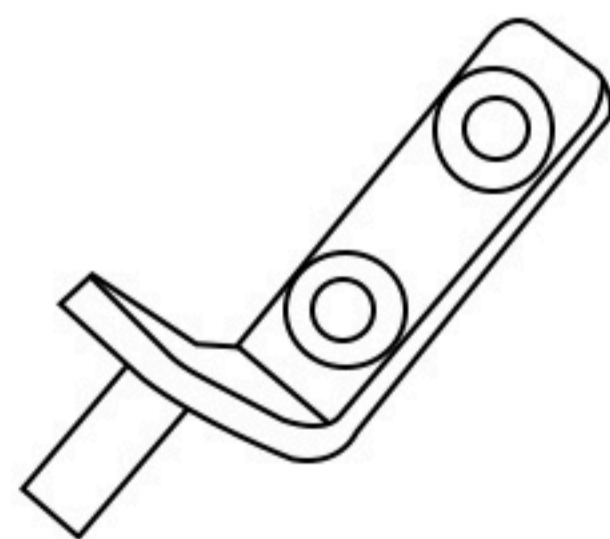

Hardware Buckle x1

**C**

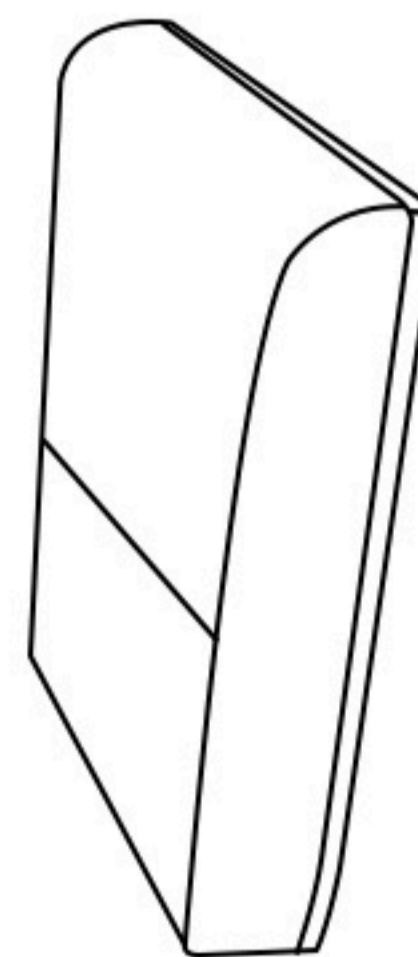

Right armrest x1

**D**



Left armrest x1

**E**

## Installation

**Step 1:** Take out the fitting at the bottom of the armrest.

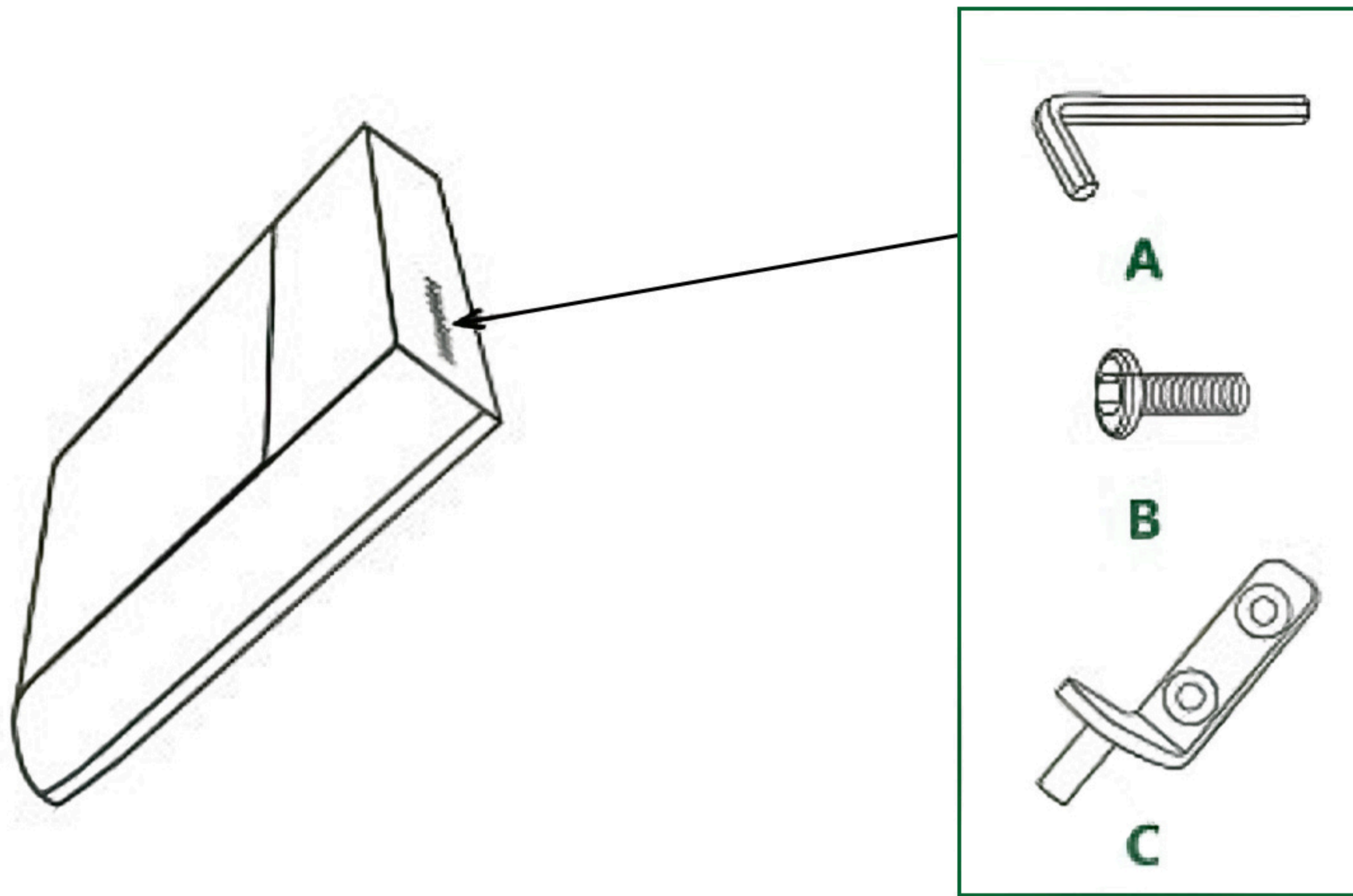

**Step 2:** Assemble the screw into the armrest hole.

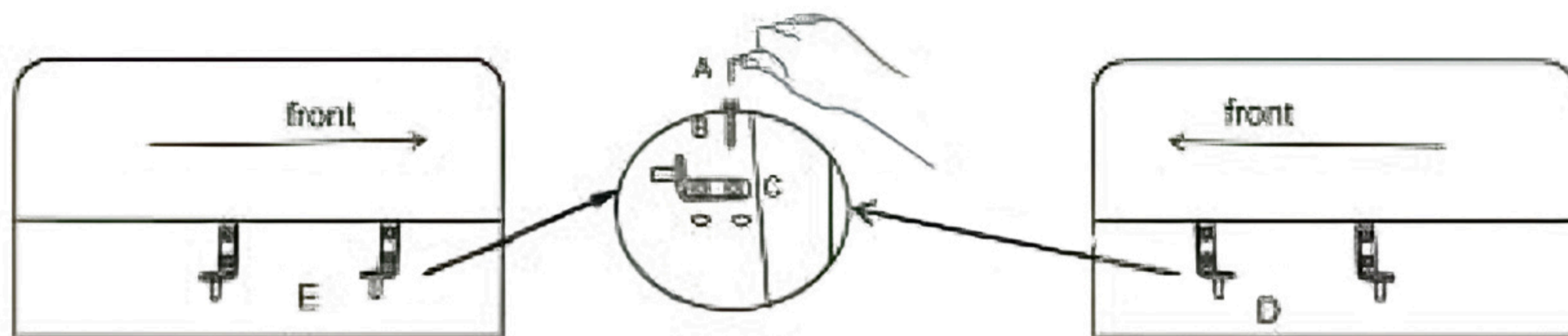

## Middle Sofa Customizable Module

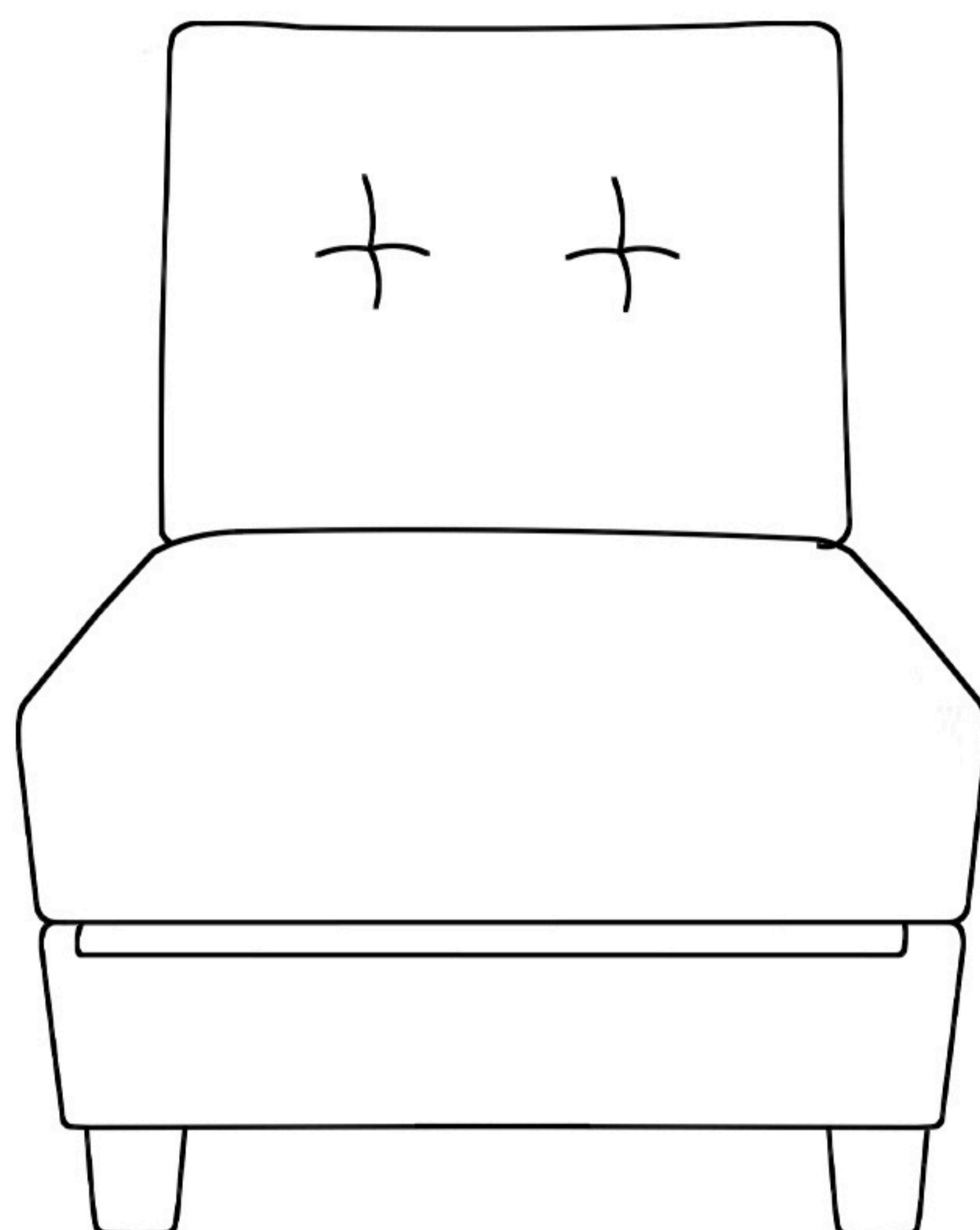

## Parts List (Checking the part lists when you get the packing--please open the)



Seatrest x1

**A**

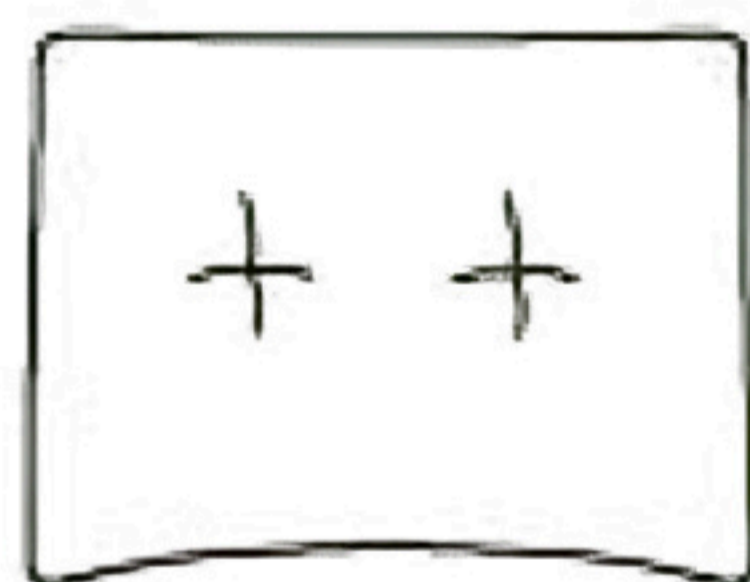

Backrest cushion x1

**B**



Backrest x1

**C**



M6 Allen Key x1

**D**



M6 Bolt x6

**E**



Hardware Buckle x2

**F**



Connector x1

**G**



Feet x4

**H**

## Warning

Warning: Put one hand on the seat rest when you open it to reduce the impact force.

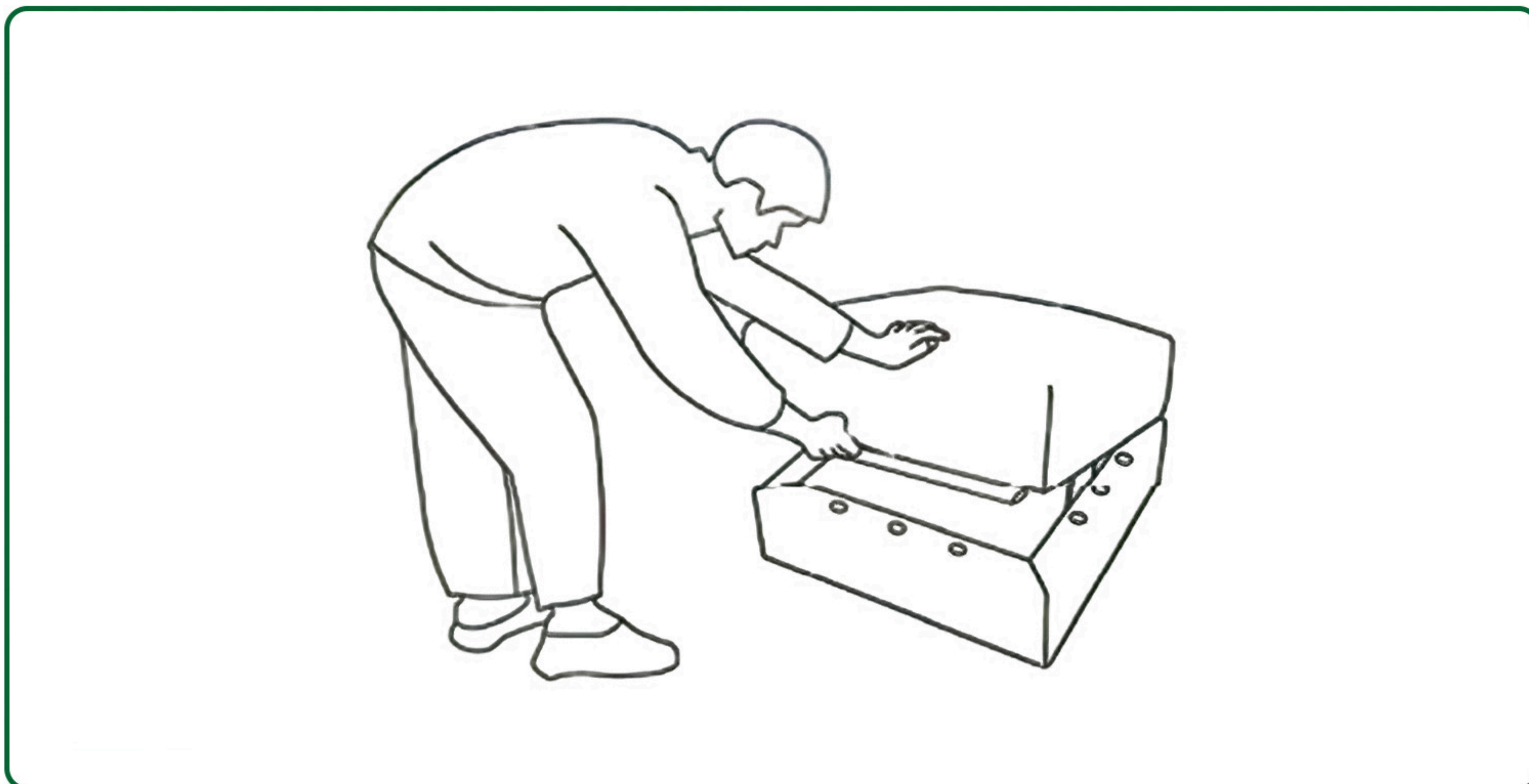

Don't put the hands into the hardware part to avoid getting injured when open and close the seat rest.

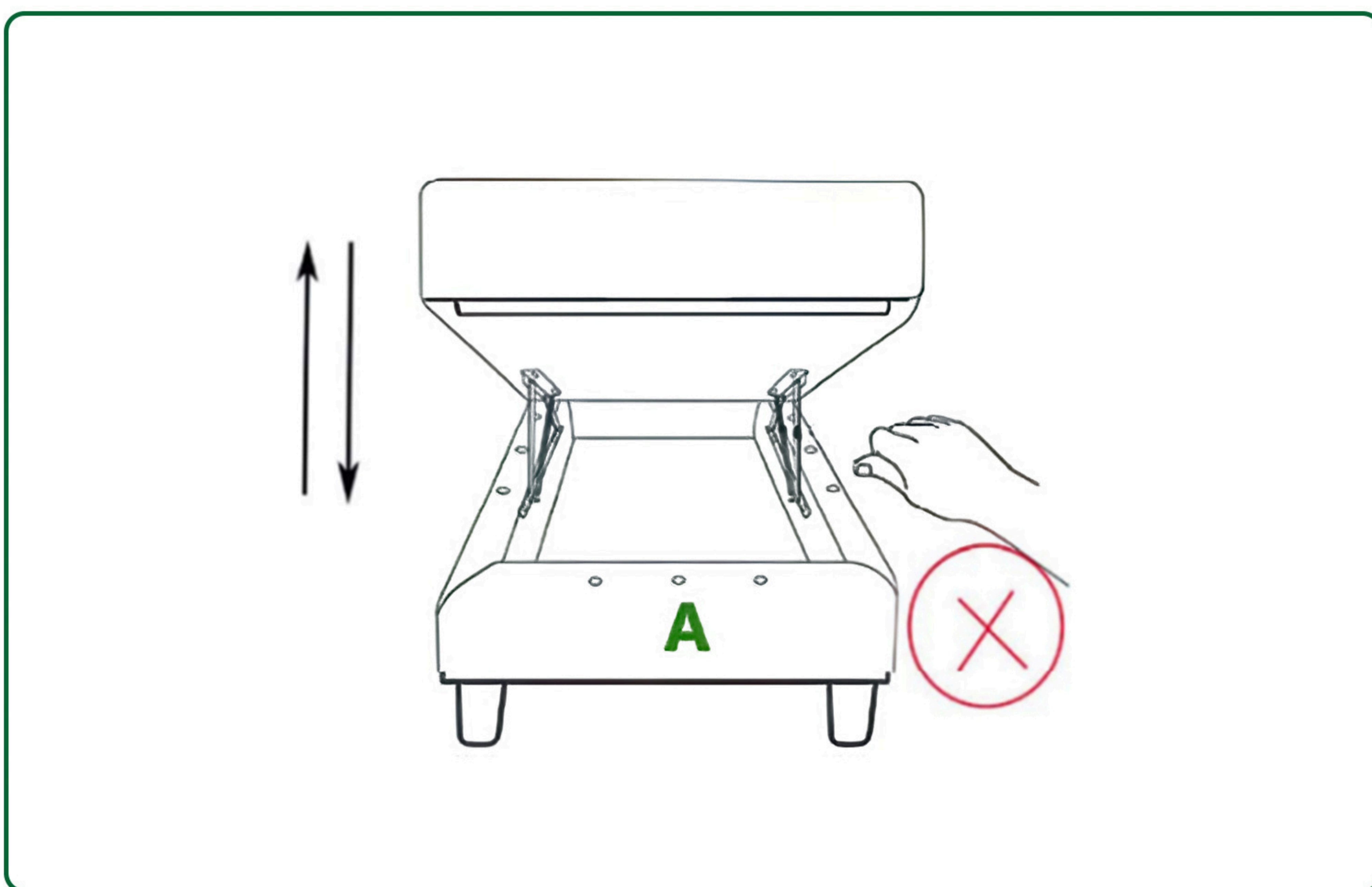

## Installation

**Step 1:** Open the seat rest **A** and take out the accessories.

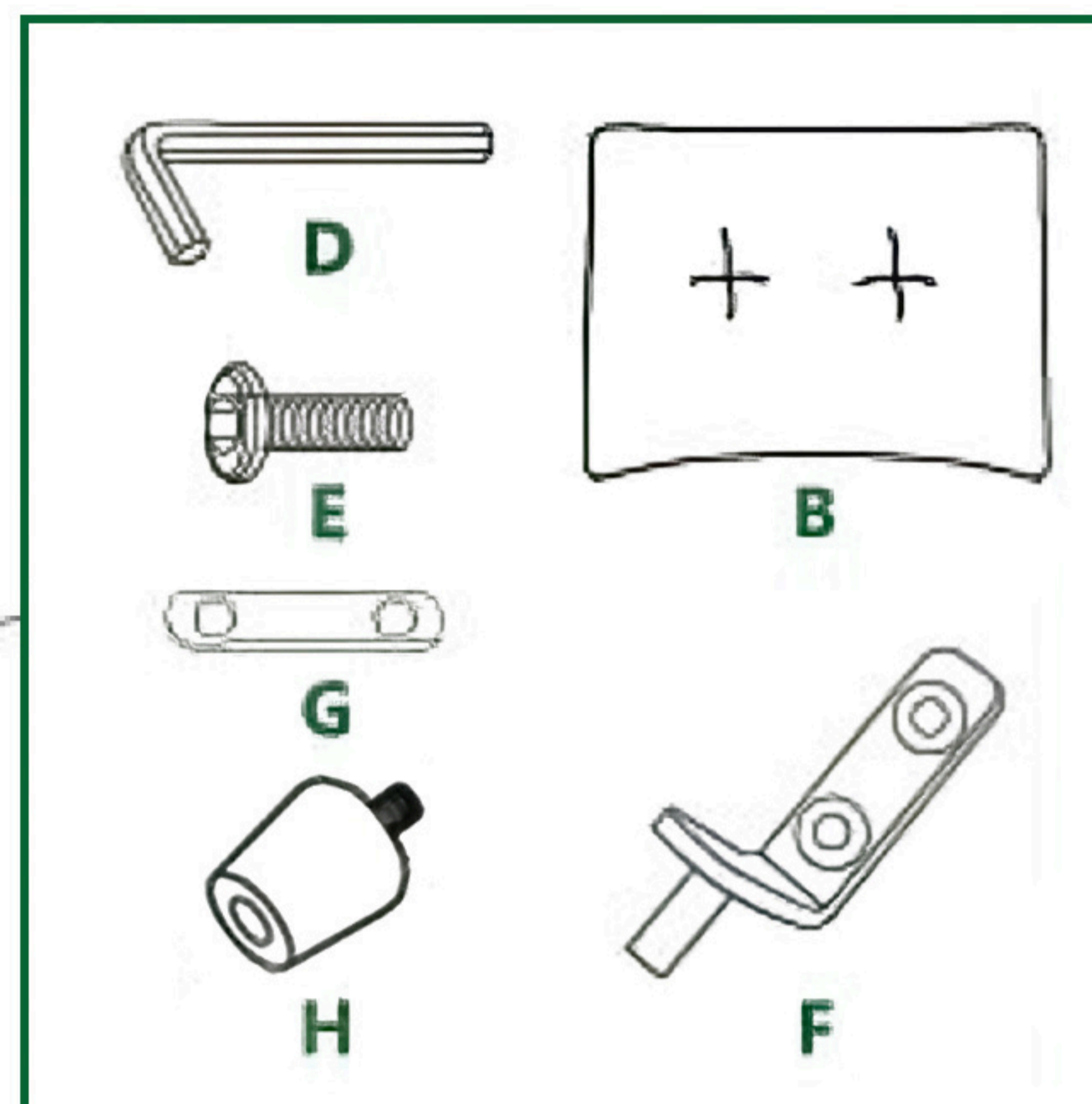
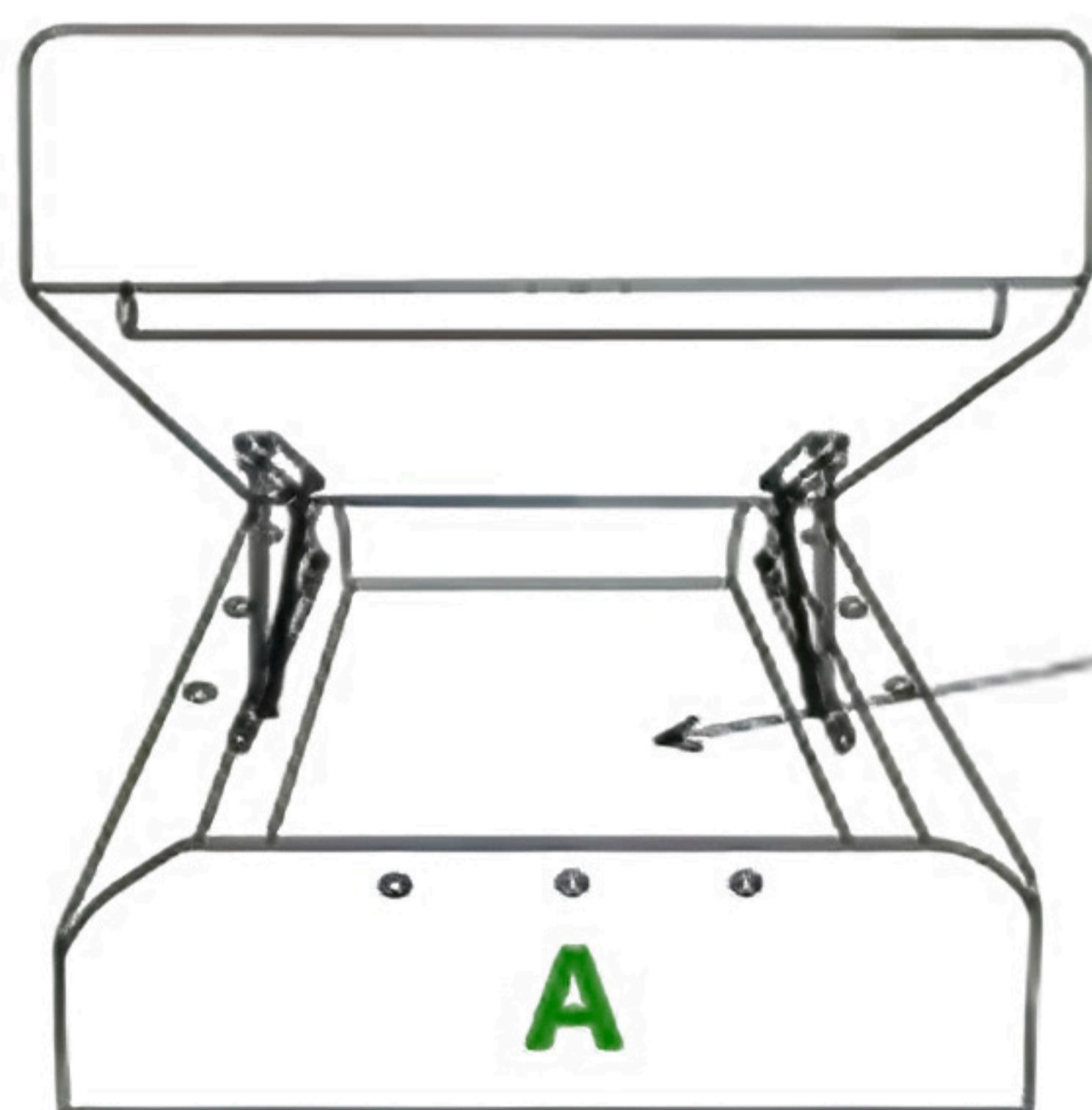

**Step 2:** Tighten the plastic foot clockwise.

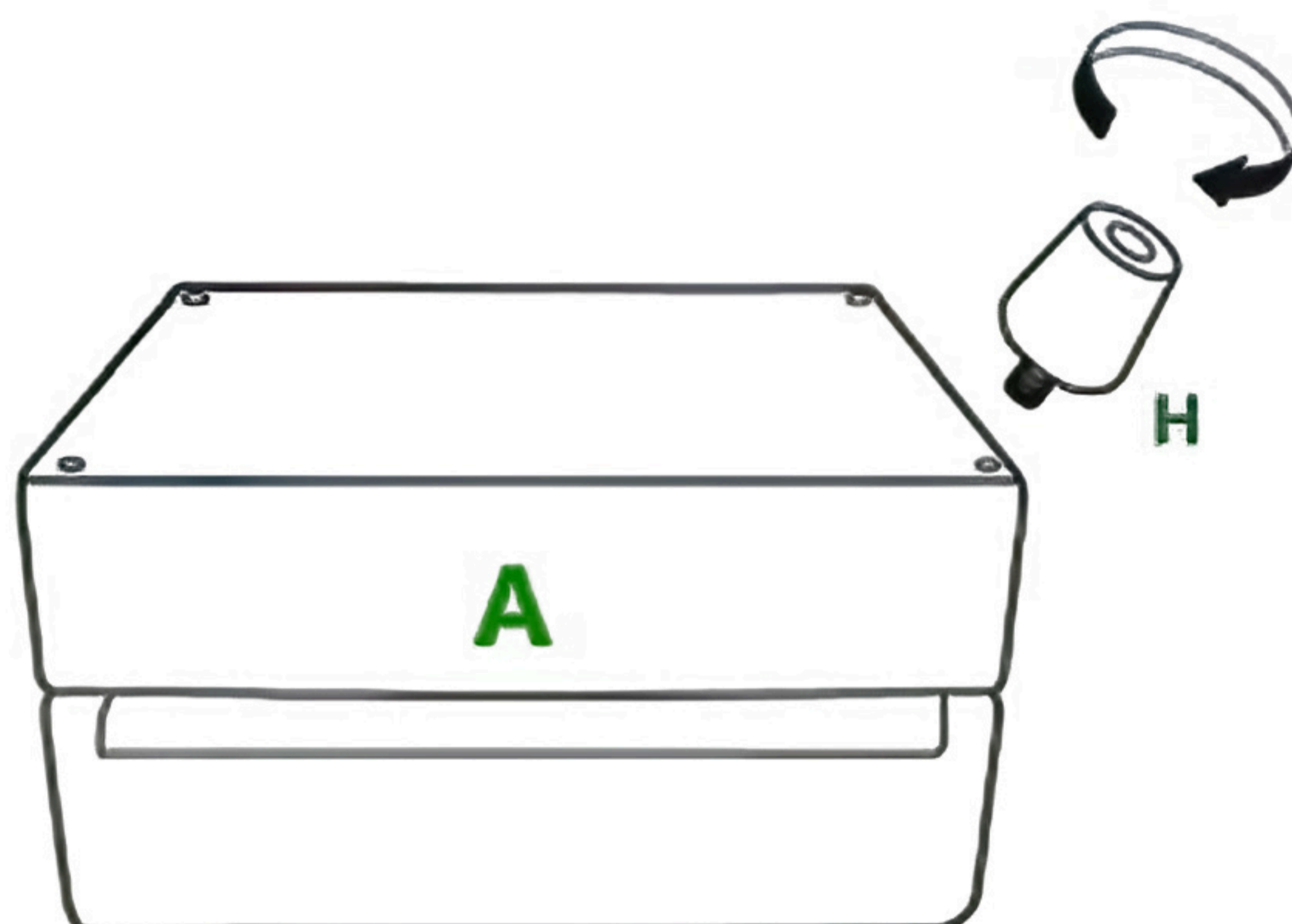

**Step 3:** Install and fasten the hardware buckle on the backrest.

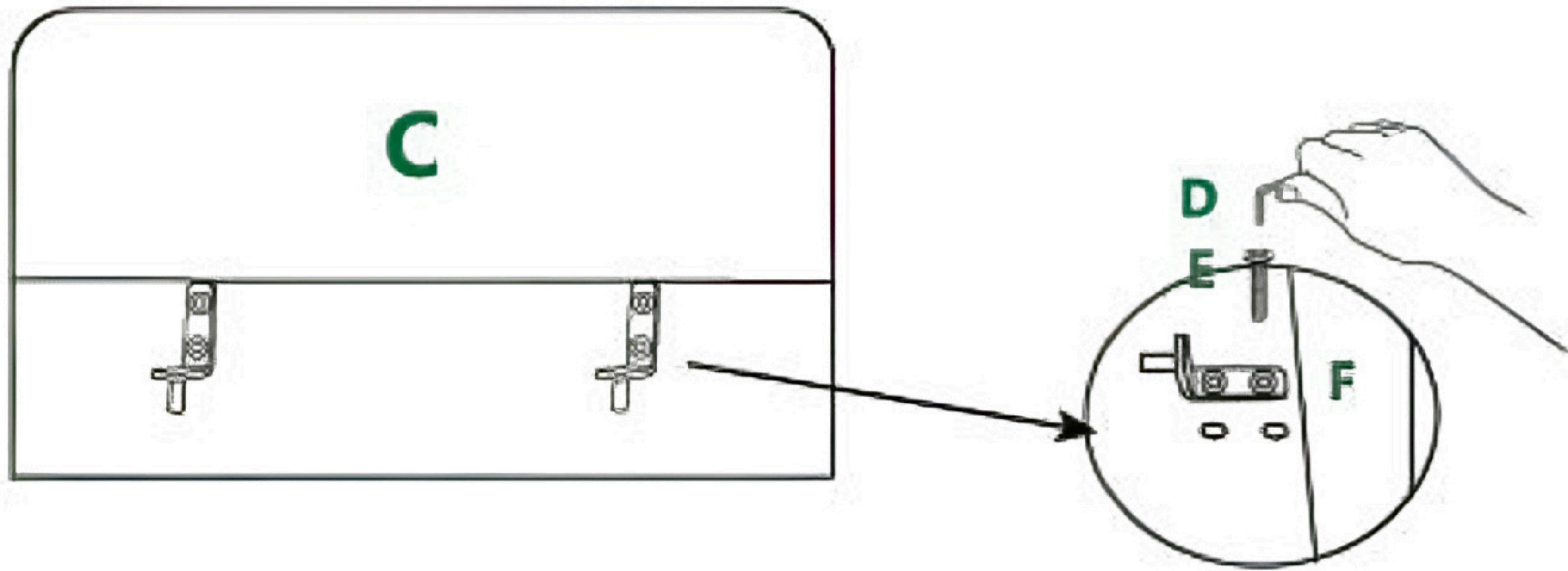

**Step 4:** Tilt the backrest and insert it to the seat rest (make sure the buckles on backrest align with the hole site on seat rest).

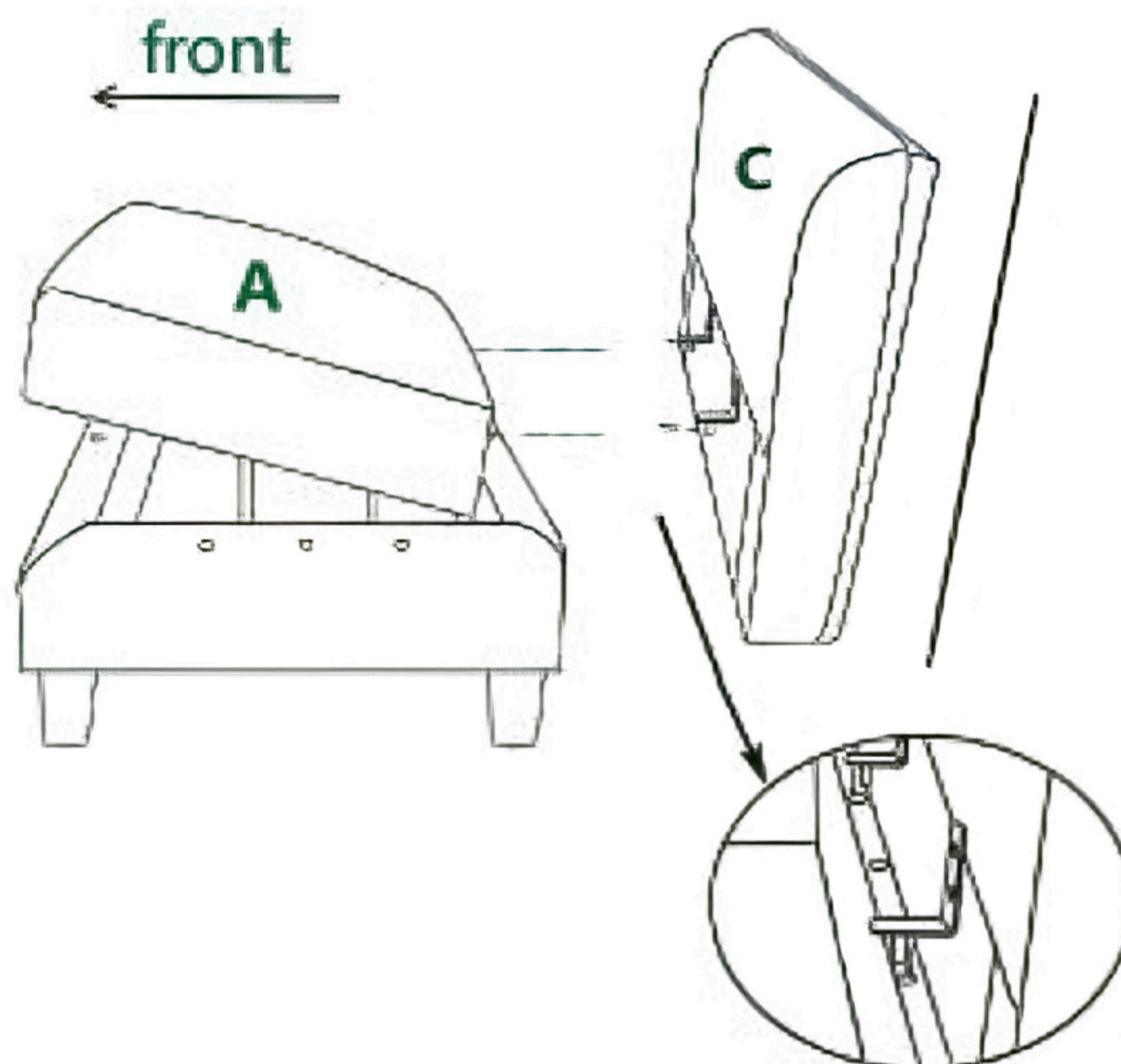

**Step 5:** Install the armrest and pay attention to the front and back direction of the armrest .

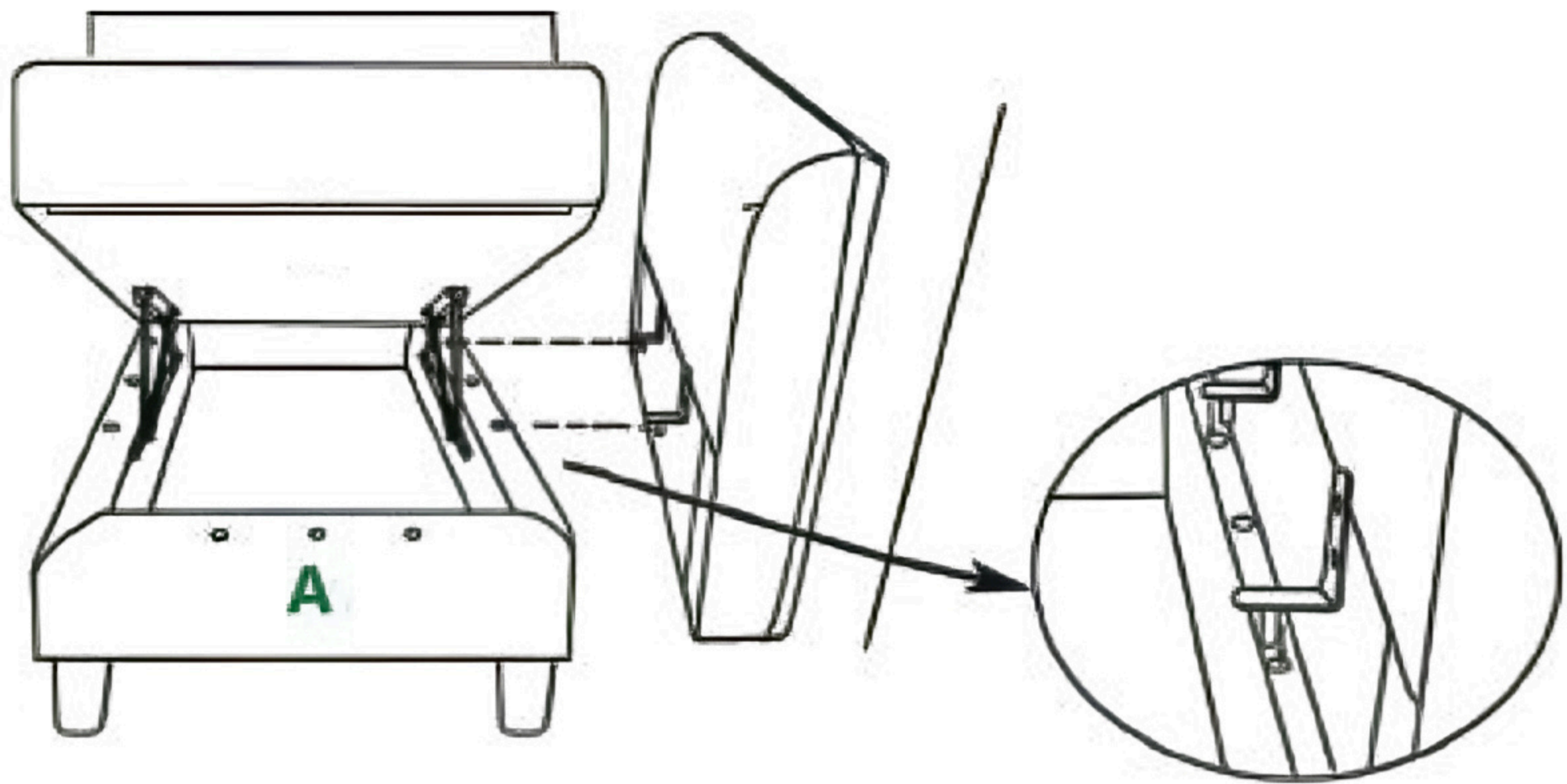

**Step 6:** Install the connecting buckle.

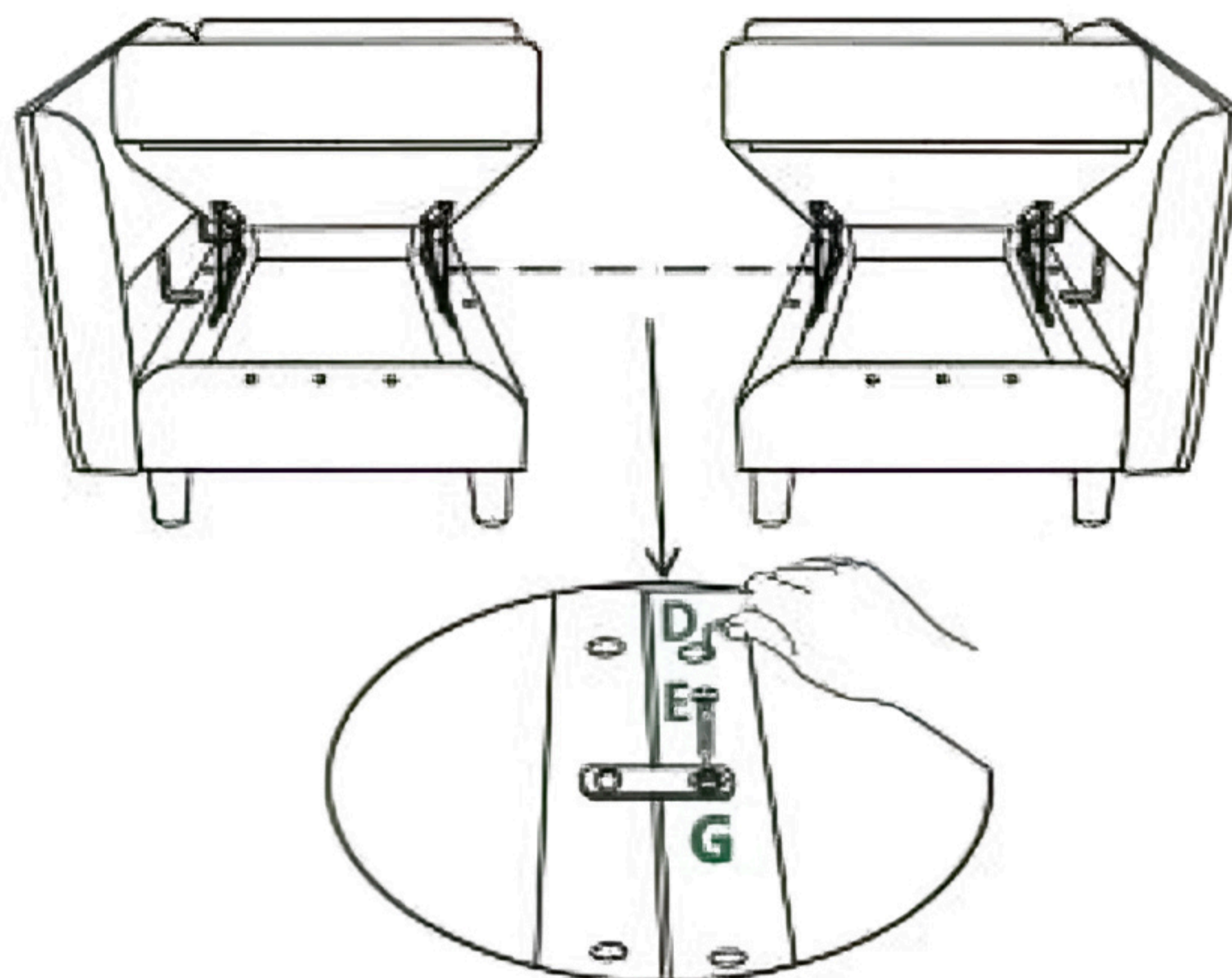

## Middle Sofa Customizable Module



## Parts List (Checking the part lists when you get the packing --please open the)



M6 Allen Key x1

**A**



Seatrest x1

**B**



Feet x4

**C**



Connector x1

**D**

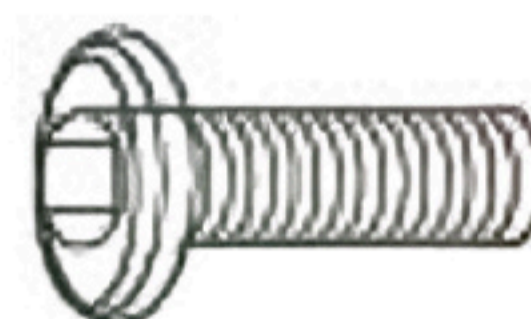

M6 Bolt x2

**E**

## Installation

**Step 1:** Open the seat rest **B** and take out the accessories.

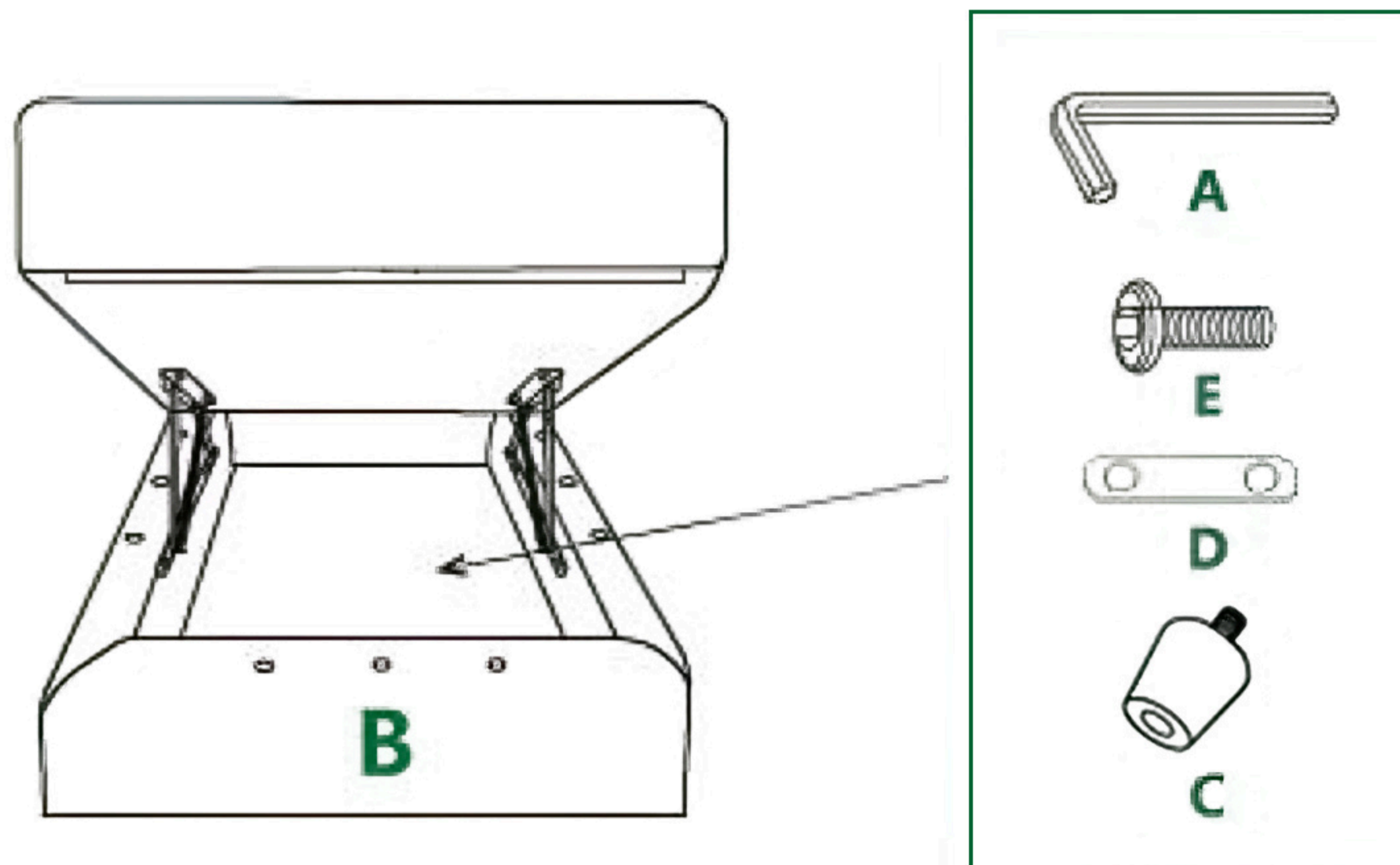

**Step 2:** Tighten the plastic foot clockwise.

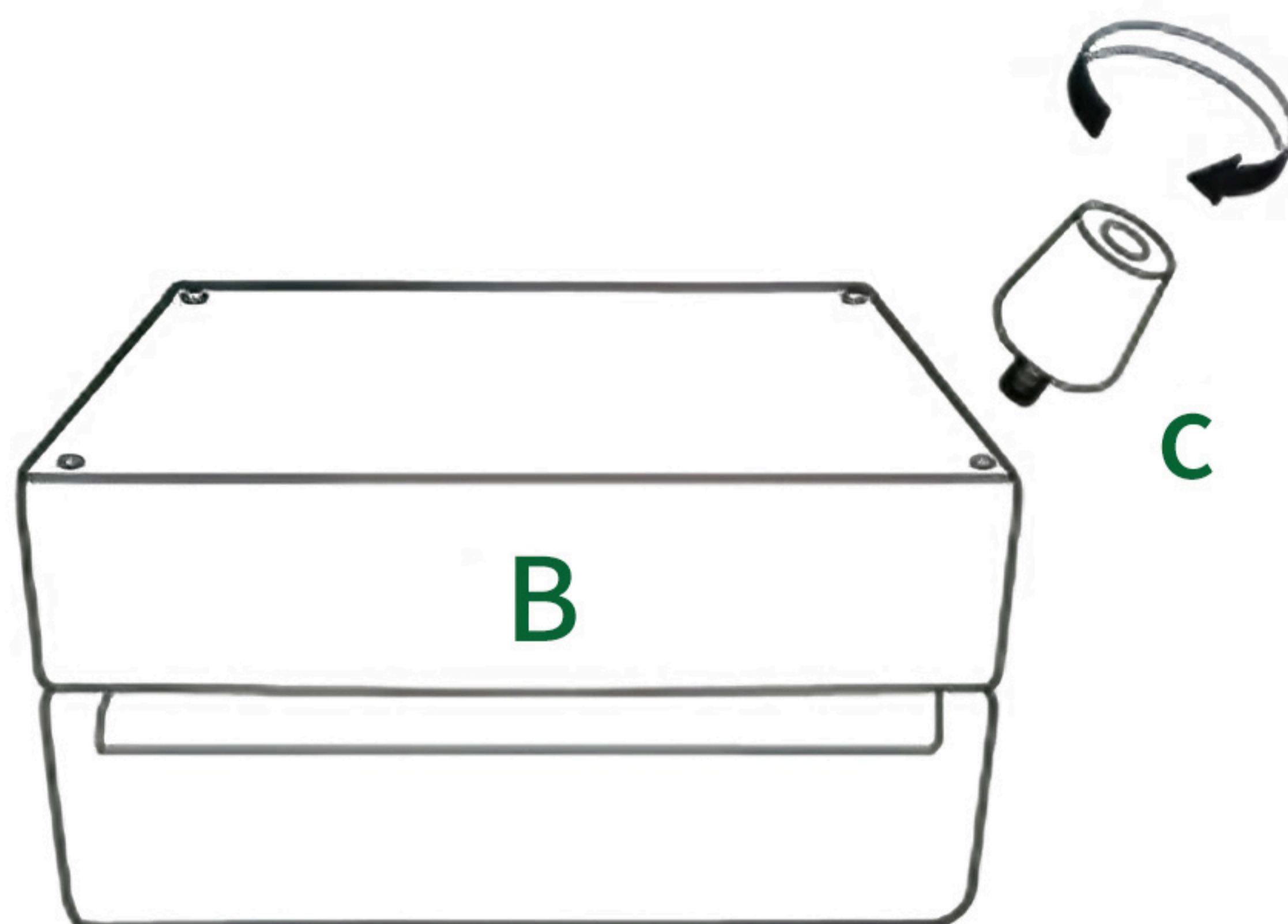

### Step 3: Install the connecting buckle.

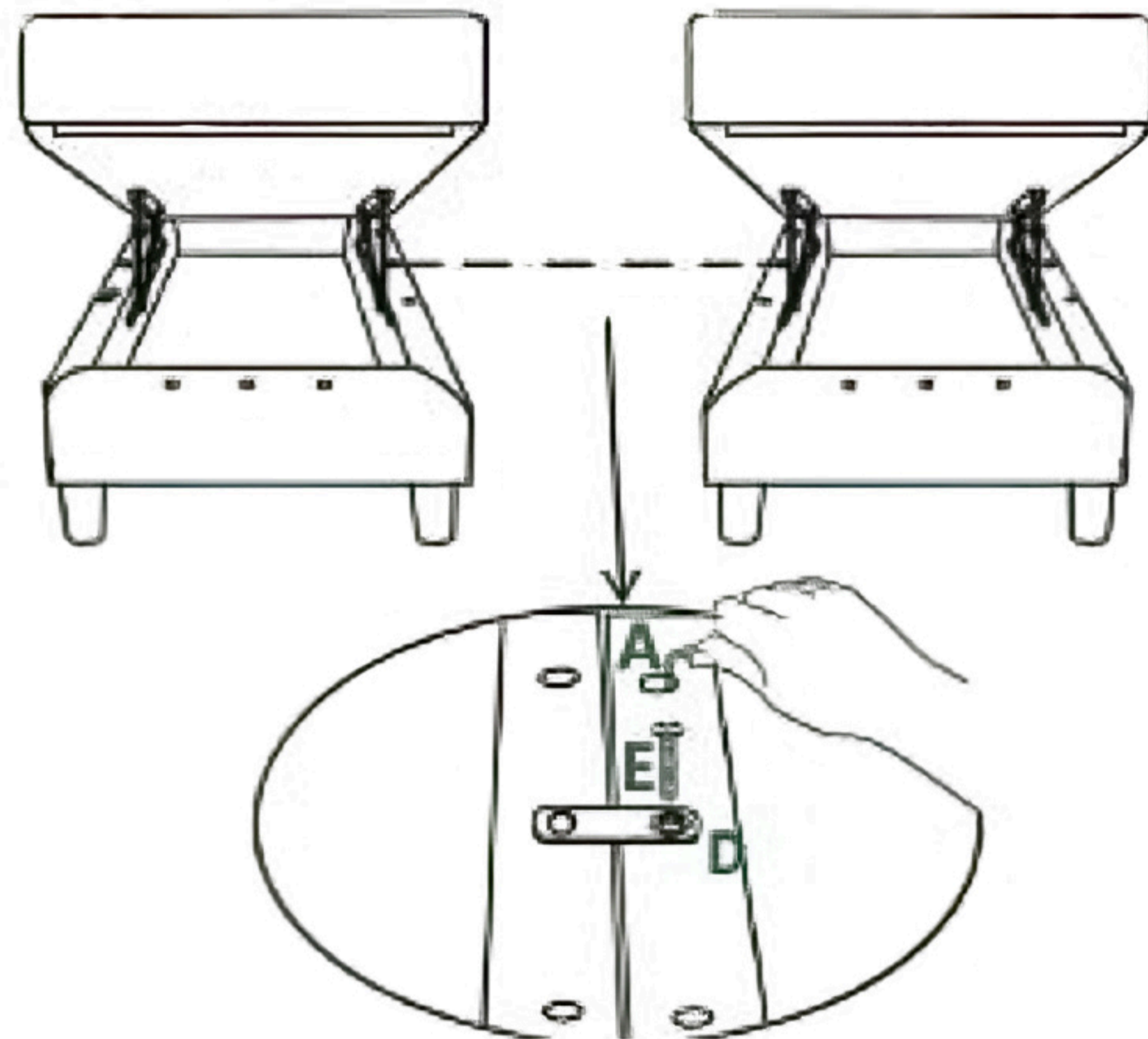

## **After sales notification**

- \*Please retain these instructions for future reference.
- \*Please read the instruction sheets completely before assembly.
- \*Assemble the sofa on a protected surface to avoid scratching the components of sofa.
- \*Be careful not to cross-thread screws.
- \*Do not use power tools.
- \*According to the fabric characteristics of sofa, please avoid direct-sun exposure.
- \*If the sofa is smelling, please try to air it for 24-48 hours and the smell will go away. Sometimes it's because it was packed for a long time, so it's very normal to get that smell.

## **Return /Damage policy**

- \*Please be sure to return the original package, otherwise, it will not be accepted by the warehouse.
- \*Take a photo of the box tracking number to help us identify your product number to ensure you receive the correct parts.
- \*Take a photo of Damage (if applicable box or products) for you can get a replacement or refund quickly.
- \*Send us an email with the images requested and a description of your claim.

