

# MT85

# 20" x 33.5" Mesh Tray

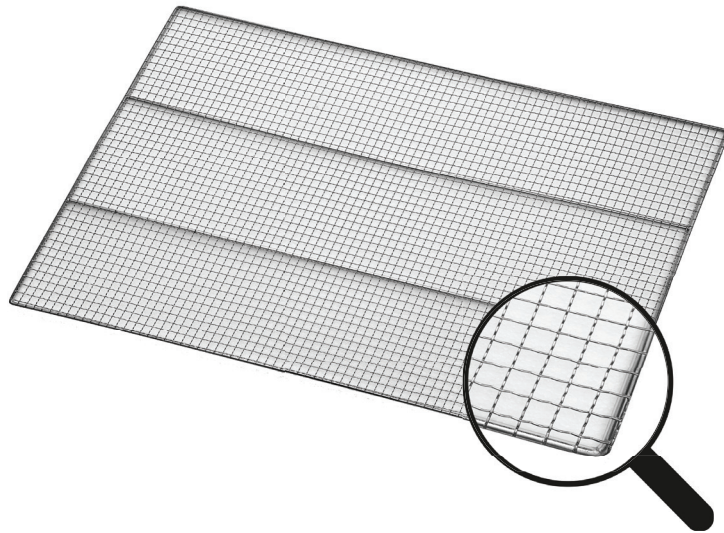

### Available Packs:

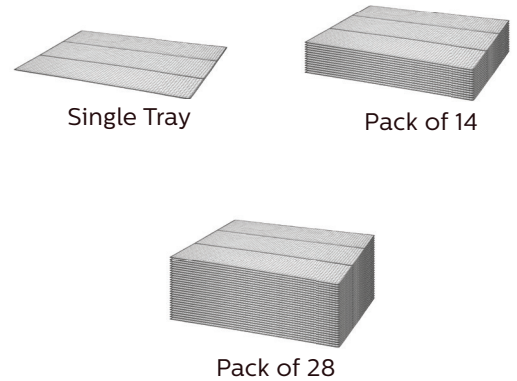

## Model: MT85

### Product specification

- Commercial Use
- Stainless Steel
- Dishwasher Safe

<b>Tray Dimensions</b>	20" x 33.5"	<b>Tray Weight</b>	2.469 lbs/tray
<b>Tray Mesh Spacing</b>	1/2" x 1/2"	<b>Available Packs</b>	Pack of 1 Pack of 14 Pack of 28
<b>Total Tray Area</b>	5 sq. ft/tray	<b>Tray Material</b>	304 Commercial Food-Grade Stainless Steel



## Cleaning Guide

It is important that your commercial food dehydrator and dehydrator trays are cleaned at the end of each drying session. This is done for many reasons:

- To ensure your food dehydrator and trays are kept in pristine condition
- To avoid cross-contamination of food
- To ensure the quality of your product is maintained
- To prevent food residue from building up and hardening on the trays

1. Clean the dehydrator and trays after each use. Ensure the machine has been turned off and the cool-down period has been completed.
2. Remove the racks from the dehydrator cabinet before cleaning.
3. Clean the dehydrator racks with warm, soapy water; rinse with clean water and dry immediately.

Racks are dishwasher-safe.