

ASSEMBLY INSTRUCTIONS



BARSTOOL

ASSEMBLY TIPS:

1. Remove hardware from box and sort by size.
2. Please check to see that all hardware and parts are present prior to start of assembly.
3. Please follow attached instructions in the same sequence as numbered to assure fast & easy assembly.

**Warning!**







1. Don't attempt to repair or modify parts that are broken or defective. Please contact the store immediately.
2. This product is for home use only and not intended for commercial establishments.









ASSEMBLY TIME

5 MINUTES

PARTS IDENTIFICATION

	PART NAME	FIGURE	QTY		PART NAME	FIGURE	QTY
A	CHAIR BACK		1PC	F	BASE		1PC
B	CHAIR SEAT		1PC	G	COVER RING		1PC
C	BACK SUPPORT		1PC				
D	GAS CYLINDER		1PC				
E	FOOT REST		1PC				

HARDWARE IDENTIFICATION

	HARDWARE NAME	FIGURE	QTY		HARDWARE NAME	FIGURE	QTY
1	BOLTS M6x20MM		3PC	6	ALLEN WRENCH M5		1PC
2	BOLTS M6x20MM		7PC	7			
3	GASKET M6x18x1.5MM		3PC	8			
4	SPRING GASKET M6		3PC	9			
5	ALLEN WRENCH M4		1PC				

ASSEMBLY INSTRUCTIONS

STEP 1

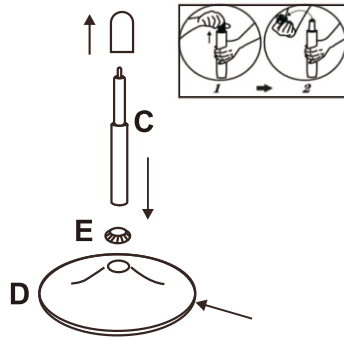

Place the chair seat (A) upside down on a soft surface. Then attach the foot rest (B) to the chair seat (A) using the bolt (1) and tighten with the allen wrench (2).

STEP 4

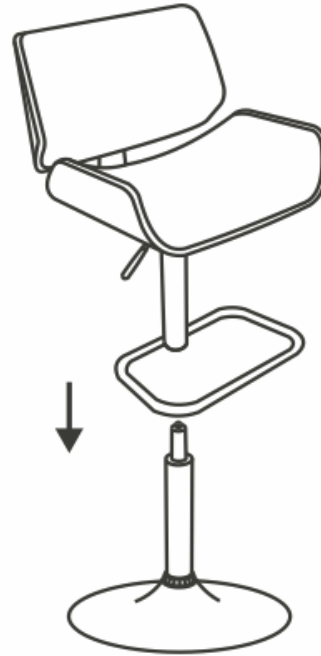

STEP 2

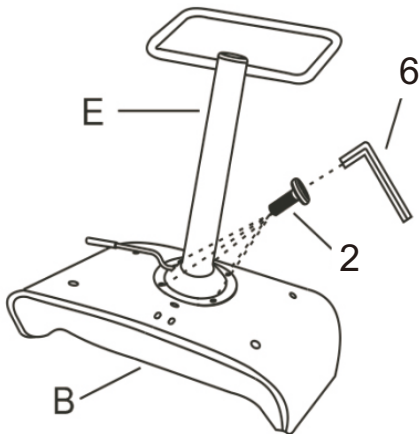

STEP 5

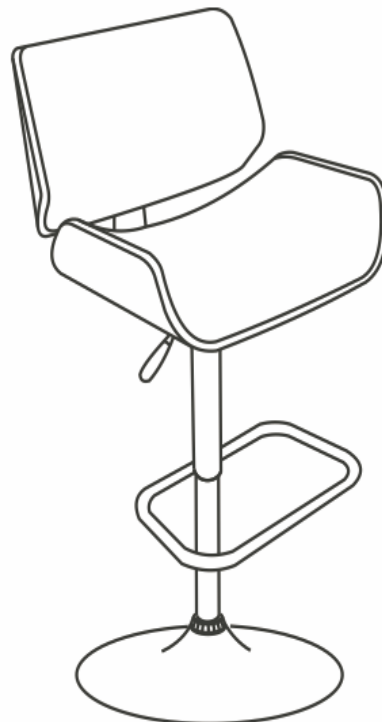

STEP 3

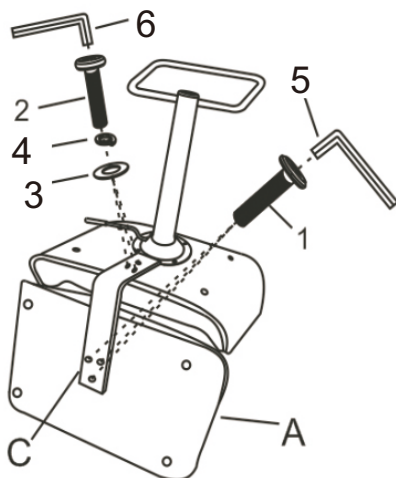

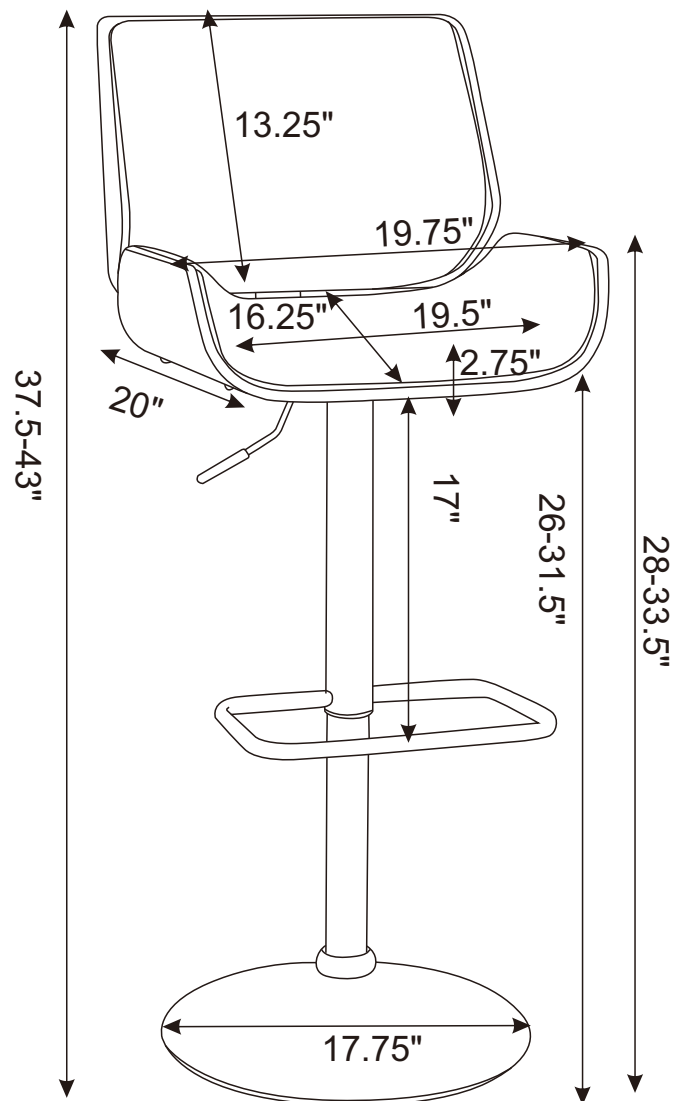

Note: Dimension tolerance $\pm 5\%$