







ASSEMBLY INSTRUCTION

(BOX 1)

| NO | PARTLIST | QTY |
|----|---|-----|
| A |  HEADBOARD PANEL | 1PC |







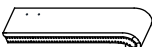

(BOX 2)

| | | |
|---|---|------|
| B |  BED SLAT | 4PCS |
| C |  FOOTBOARD PANEL | 1PC |
| D |  FOOTBOARD LEG | 2PCS |
| E |  BED SLAT SUPPORT WITH LEVELER | 4PCS |
| F |  LEFT BED RAIL | 1PC |
| G |  RIGHT BED RAIL | 1PC |

(BOX 3)

| | | |
|---|--|-----|
| H |  LEFT WING | 1PC |
| I |  RIGHT WING | 1PC |

(BOX 2)

| NO | HARDWARE | QTY |
|----|---|------|
| 1 |  JCBB SCREW M8 x 20mm | 4PCS |
| 2 |  JCBC SCREW M6 x 16mm | 6PCS |
| 3 |  JCBC SCREW M6 x 35mm | 4PCS |
| 4 |  JCBC SCREW + WASHER M6 x 35mm | 6PCS |
| 5 |  JCBB SCREW + WASHER M8 x 60mm | 4PCS |
| 6 |  WOOD DOWEL M10 x 30mm | 4PCS |
| 7 |  CHIPBOARD SCREW M4 x 32mm | 8PCS |
| 8 |  L - KEY M4 x 100mm | 1PC |
| 9 |  L - KEY M5 x 65mm | 1PC |

NOTE : THE HARDWARE PACK IN BOX 2

STEP 1

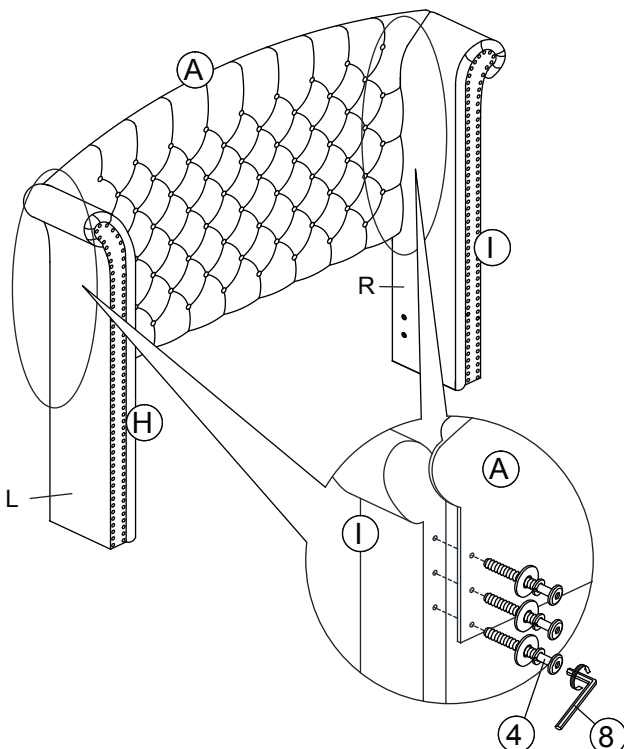

STEP 2

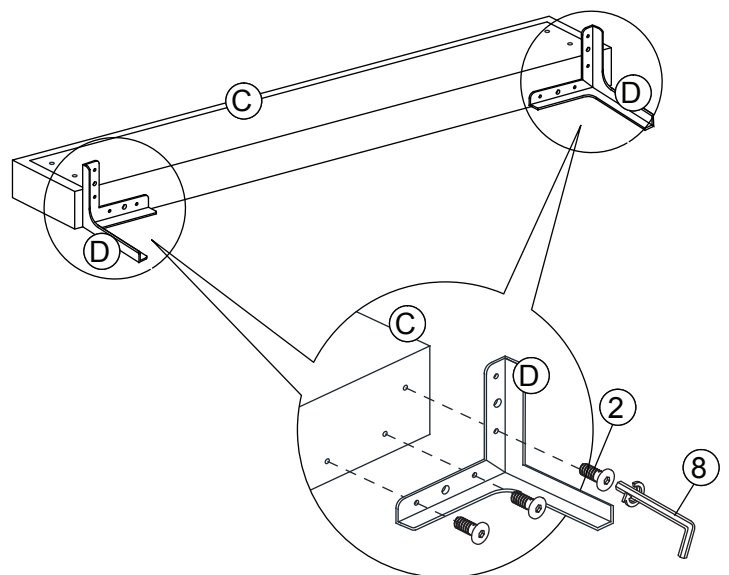

THE HARDWARE ID LOCATED IN THE PACKING ITEMS

NOTE : MUST TIGHT SCREWS PERIODICALL WITH USE SCREWS MAY BECOME LOOSE.
CHECK TIGHTNESS OF ALL SCREWS EVERY 6-8 WEEKS.

ASSEMBLY INSTRUCTION

STEP 3

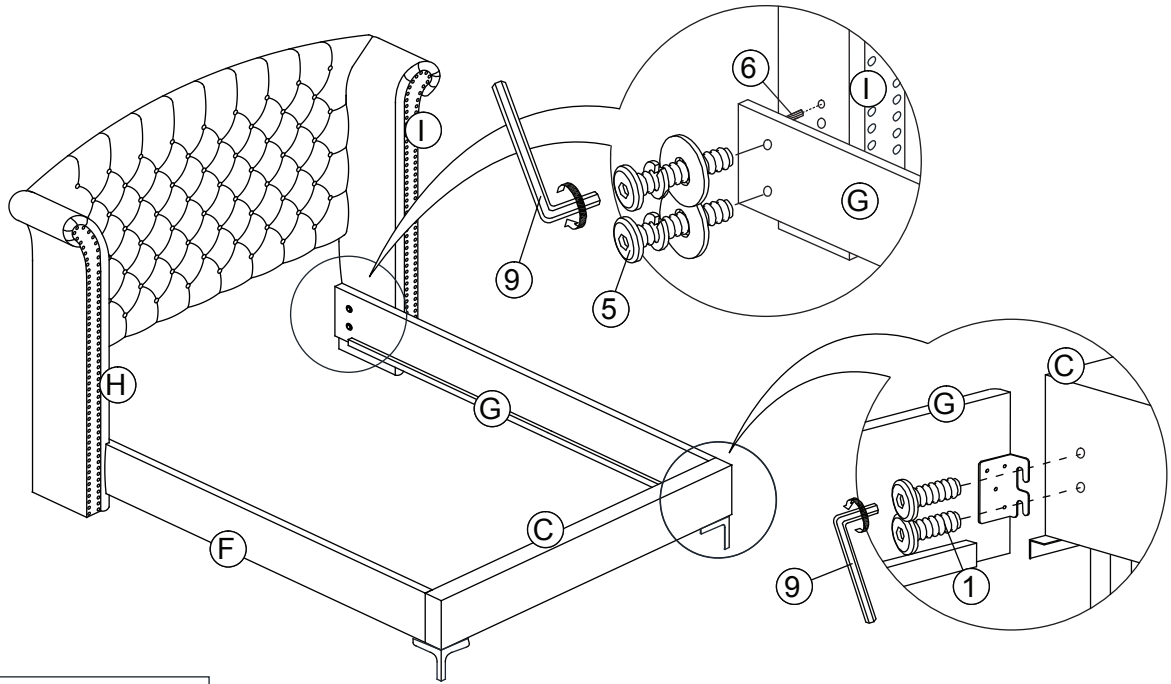

Do not fully tighten screws until assembly is complete and the bed is level.

STEP 4

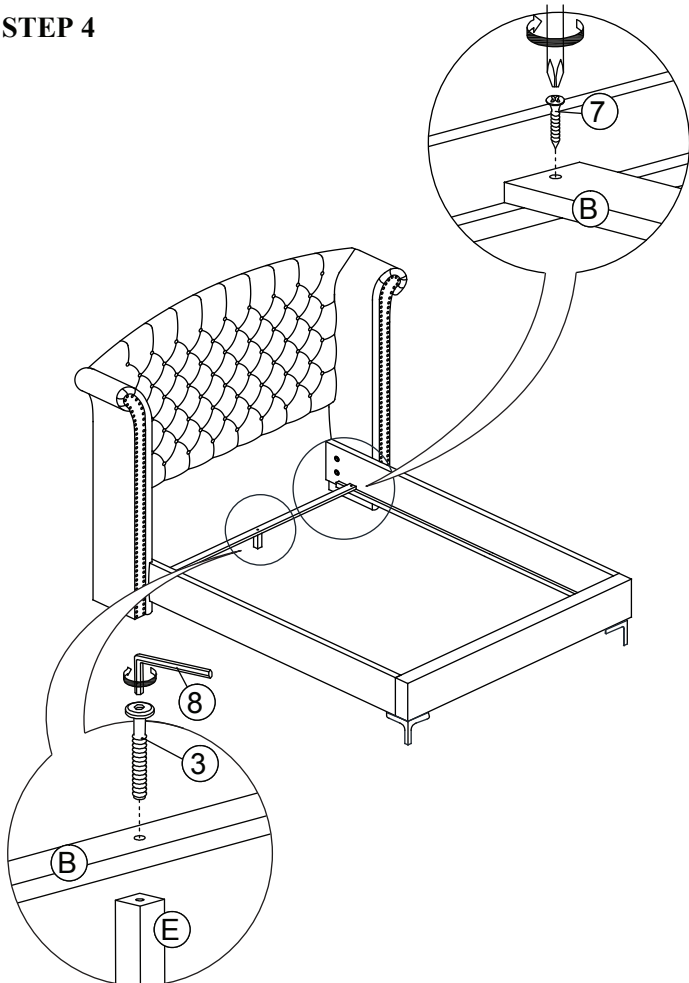

STEP 5

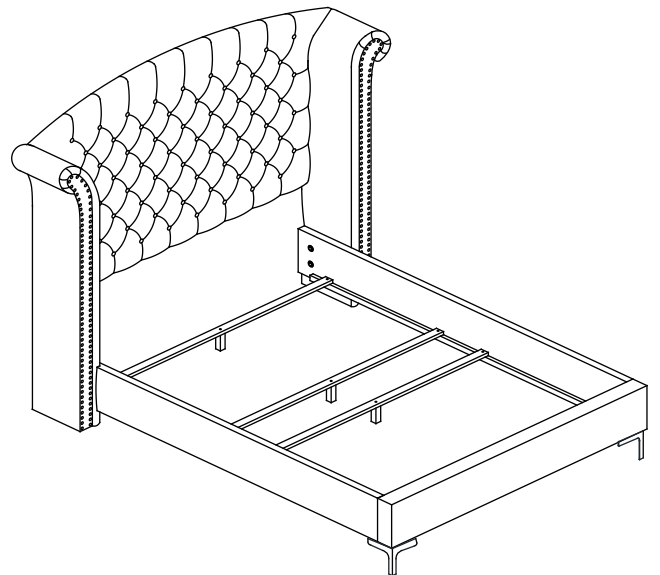

THE HARDWARE ID LOCATED IN THE PACKING ITEMS

NOTE : MUST TIGHT SCREWS PERIODICALL WITH USE SCREWS MAY BECOME LOOSE.
CHECK TIGHTNESS OF ALL SCREWS EVERY 6-8 WEEKS.