



Assembly Instructions

 Before you throw the carton, please ensure that you have all the parts needed for the assembly.

 **Hardware Note:**

1. For each step please don't fully tighten all the screws at first, when they all align to the holes you can fully tighten them.

2. All the bolts should be assembled **vertically** to the holes.

 **Spare parts** can be found in the hardware box if you do not have enough bolts for assembly.



2pcs

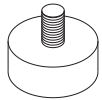

1pc

(foot end caps)

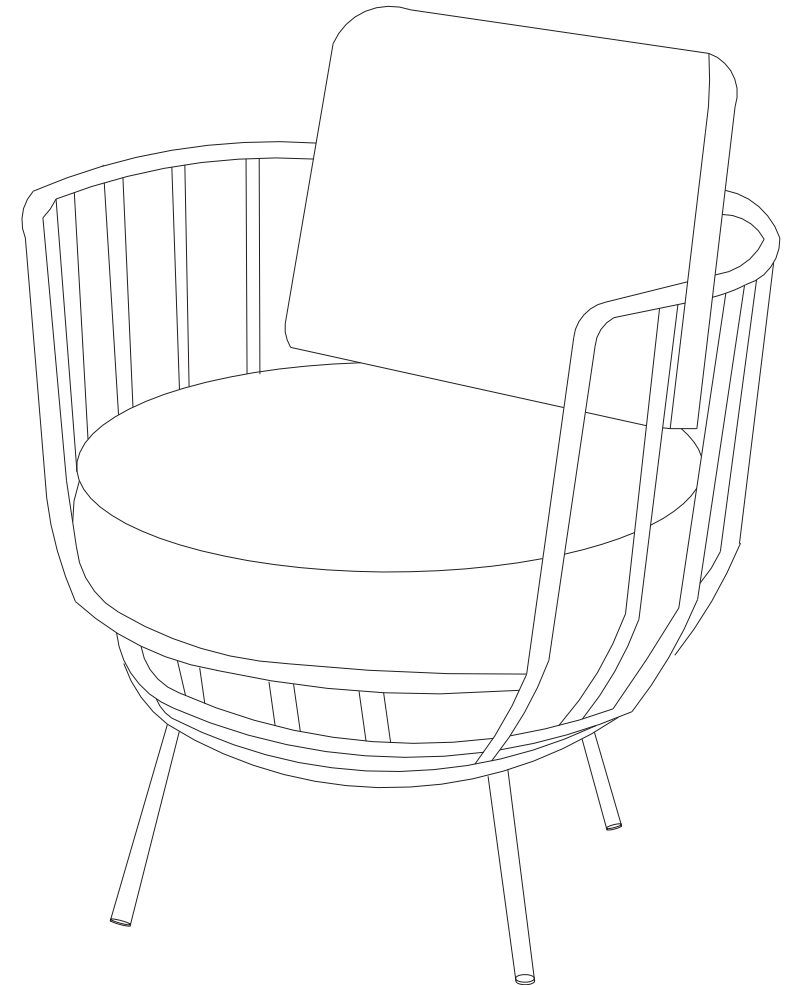

 THIS INSTRUCTION BOOKLET CONTAINS IMPORTANT SAFETY INFORMATION. PLEASE READ AND KEEP FOR FUTURE REFERENCE.

Assembly Instructions

MADE IN CHINA

Parts and Hardware

Please check to make sure you have all parts and hardware before starting assembly process.

A

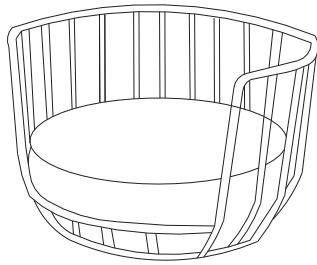

Seat 1pc

B

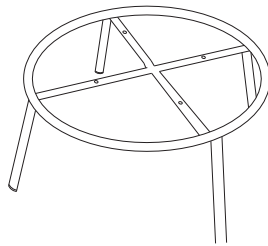

Leg 1pc

C

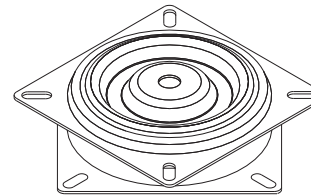

Swivel plate 1pc

D

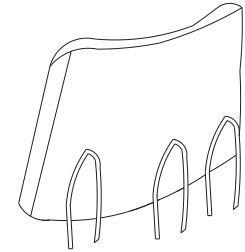

Back cushion 1pc

1

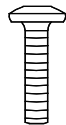

Bolts 8pcs

1

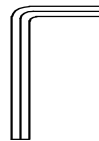

Wrench 1pc

Assembly Instructions

MADE IN CHINA

Assembly Instructions

Step 1: Assemble the swivel plate to leg using bolts 1. Half tighten the bolts one by one until all the bolts are align to the holes then fully tighten them by the short side of wrench.

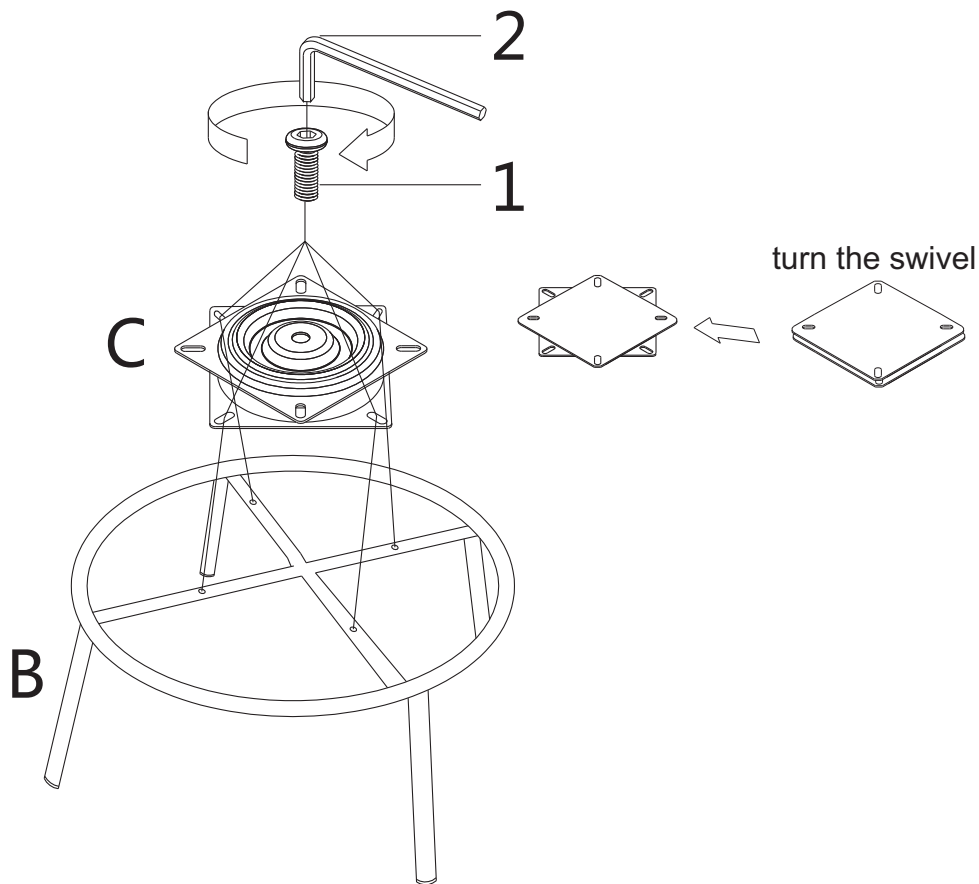

Step 2: Assemble leg to the bottom of seat using bolts 1. Half tighten the bolts one by one until all of them are align to the holes then fully tighten them by the short side of wrench.

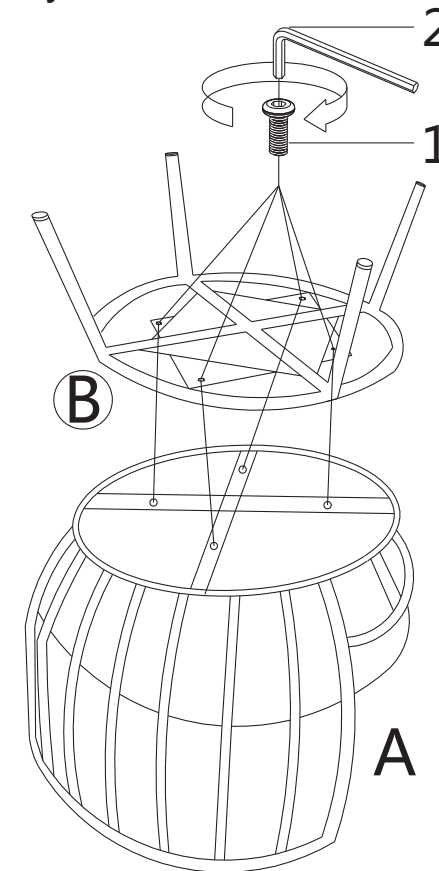

Assembly Instructions

MADE IN CHINA

Assembly Instructions

Step 3: Tie knots using the rope on the back of back cushion.

