

# HAPPINESS HAPPINESS INSTALLATION

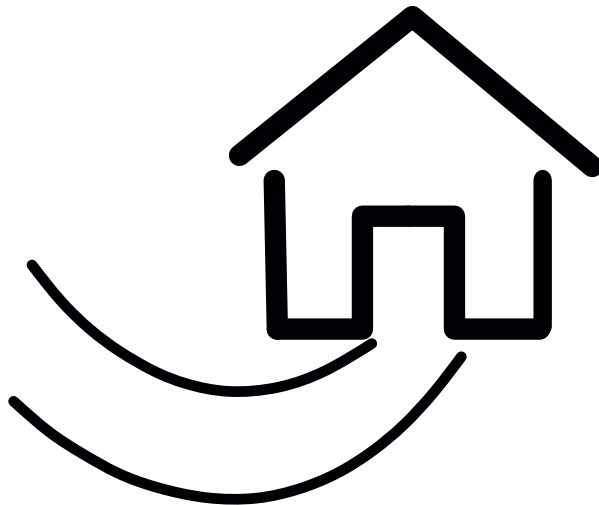

## CAUTION

Parts are placed at the bottom of the product.

- If you have any questions with the product, please contact us by:
- **Email: [customerservice@zoy-living.com](mailto:customerservice@zoy-living.com)**  
(we will reply to you within 24 hours)



# Assembly Instructions

**5558-3**

Your sofa is packaged in one box. Carefully remove all components from the packaging and set them aside for assembly.

**CAUTION:**  
DO NOT use any sharp objects to open plastic wrapped components as this may result damage to product or components

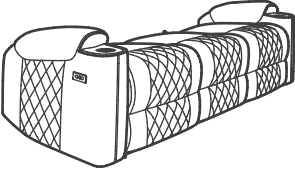
## Package Contents

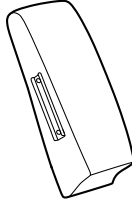
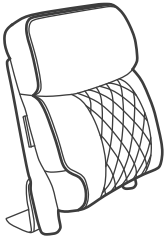
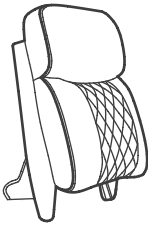
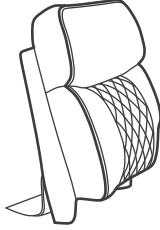
			
<b>Part A*1 Seat Body</b>	<b>Part B*1 Adapter</b>	<b>Part C*1 Left Ear</b>	<b>Part D*1 Right Ear</b>
			
<b>Part E*1 Left Backrest</b>	<b>Part F*1 Middle Backrest</b>	<b>Part G*1 Right Backrest</b>	

**STEP 1** Attach the **Left Backrest (E)**, the **Middle Backrest (F)** and **Right Backrest (G)** to the **Seat Body (A)** by aligning the metal sliders.

**STEP 2** Attach the **Left Ear (C)** to **Left Backrest (E)** and the **Right Ear (D)** to the **Right Backrest (G)**.

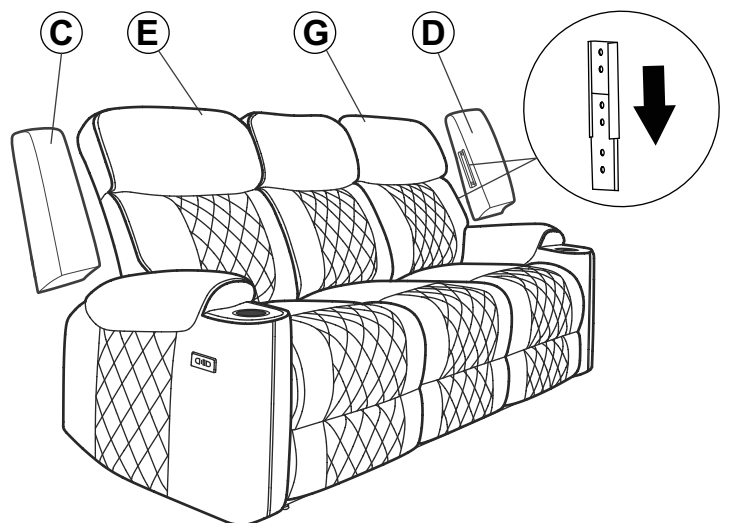
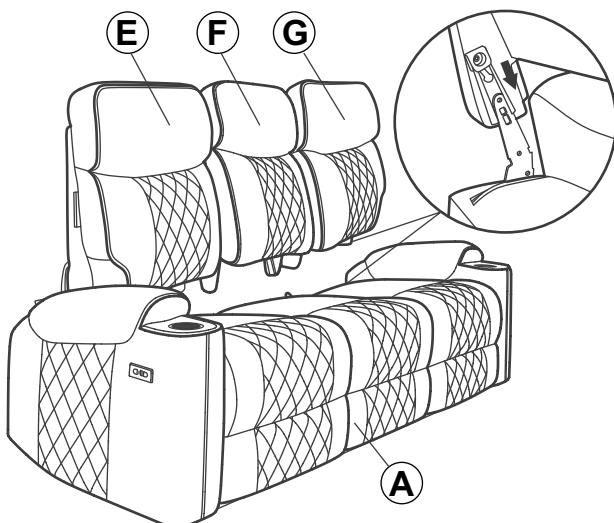

**STEP 3** First, connect one end of the **Adapter (B)** cable to the connector from the bottom of the **Seat Body (A)**. Then, plug the remaining end into power outlet.

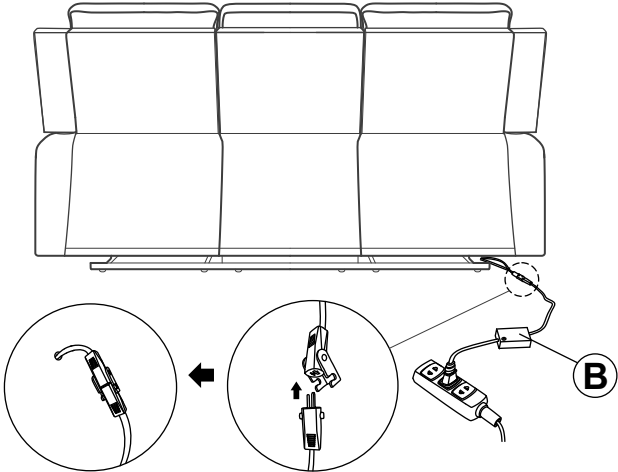

**STEP 4** Assembly completed.

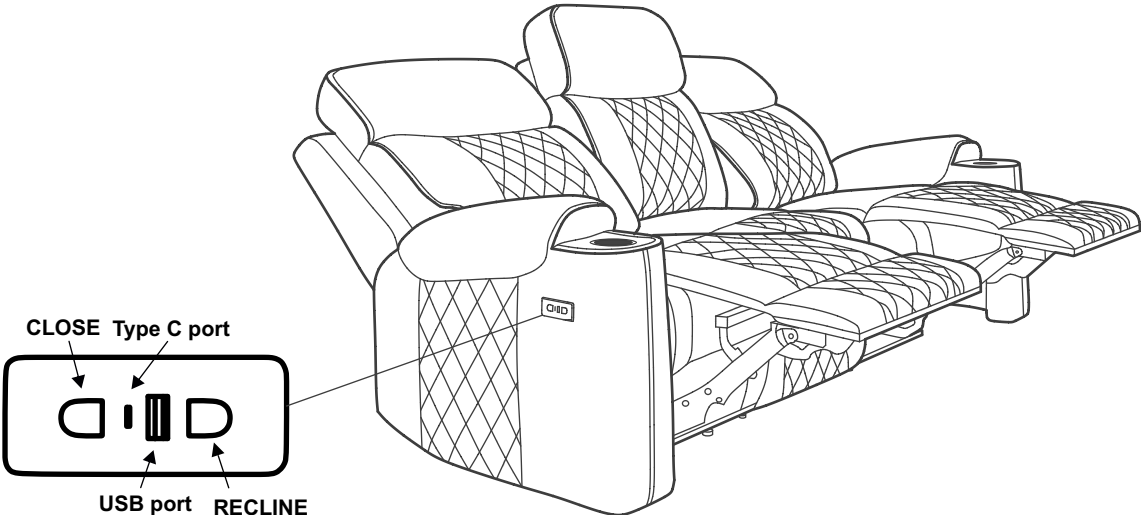
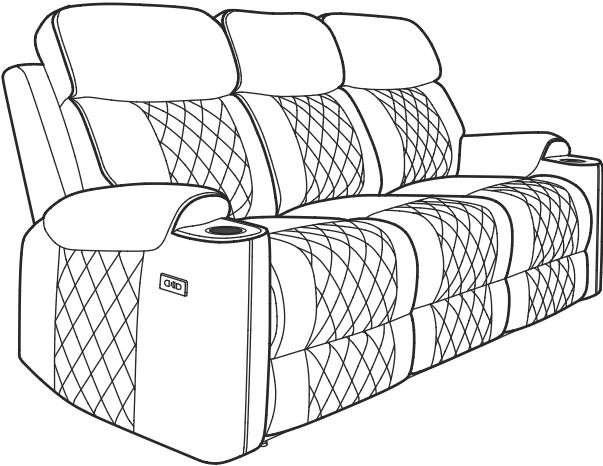

# SIZE DIMENSIONS

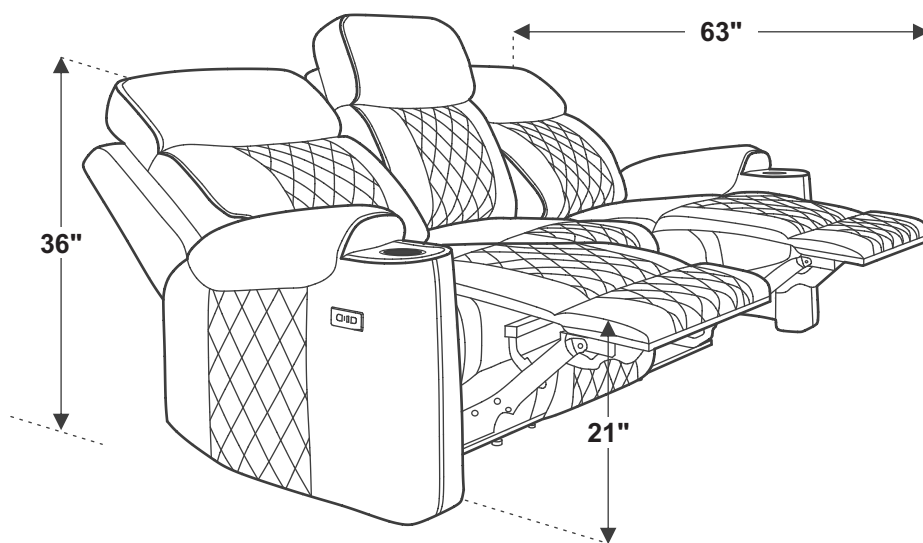
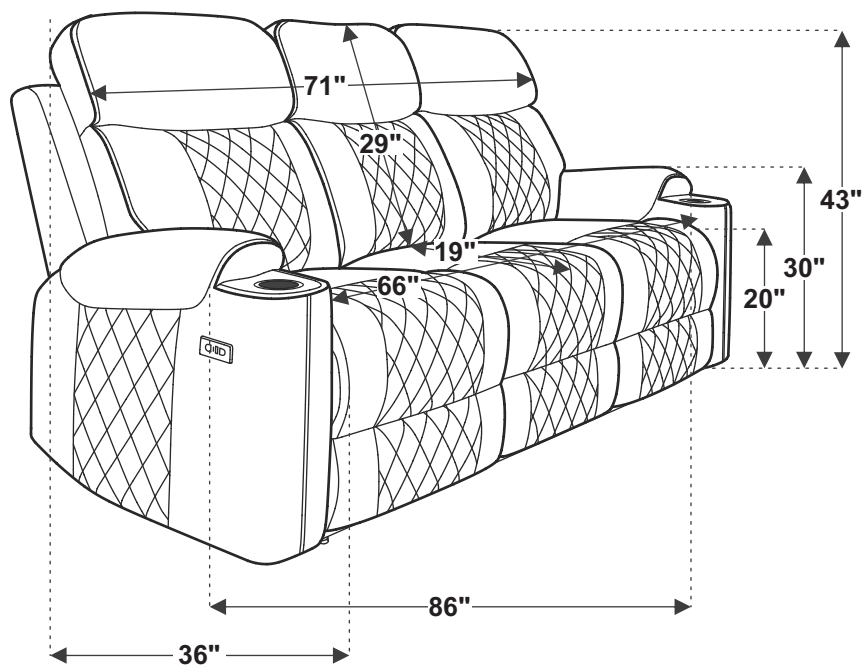

## Warnings

1. Please check if the components of the chair are all included and can be used normally.
2. Assemble all components according to the instruction correctly before you connect the chair to the power.
3. Please DO NOT sit on the armrests or footrest to eliminate the risk of tipping over.
4. If the chair is damaged or doesn't match the website description, please send clear pictures of the product and label of the carton to our service team for further help.
5. If the recliner doesn't work, you may try the following measures for self-checking firstly:
  - a) Check if all the cables are connected;
  - b) Check if the light of transformer is on.If the chair still doesn't work, please feed the information back to our customer service in time and we'll help you solve the matter as soon as possible.
6. If you have any questions with the product, please contact us by:

Email: [customerservice@zoy-living.com](mailto:customerservice@zoy-living.com) (we will reply to you within 24 hours)

