

End Table

Assembly Instructions

Montageanleitung

Instrucciones de ensamblaje

Instructions de montage

Istruzioni di montaggio



English

WARNING!

Wipe clean with a damp cloth.

Wipe dry with a clean cloth.

Check regularly that all assembly fastenings are properly tightened and retighten when necessary.

Français

ATTENTION!

Nettoyer à l'aide d'un chiffon humide.

Terminer en essuyant avec un chiffon sec.

Vérifiez régulièrement que toutes les fixations soient bien serrées et resserrez si nécessaire.

Deutsch

ACHTUNG!

Mit einem feuchten Tuch abwischen.

Mit trockenem Tuch nachwischen.

Regelmäßig kontrollieren, dass alle Beschläge und Verschraubungen gut festgezogen sind und sie bei Bedarf nachziehen.

Italiano

AVVERTENZA!

Pulisci con un panno umido.

Asciuga con un panno pulito.

Controlla regolarmente che tutti gli elementi di fissaggio siano stretti bene e, se necessario, serrali nuovamente.

Español

ADVERTENCIA!

Limpiar con un paño húmedo.

Secar con un paño seco.

Comprueba regularmente que las fijaciones estén bien apretadas y vuelve a apretarlas en caso necesario.

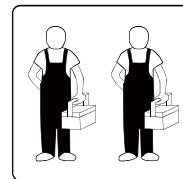

i Tools Required :

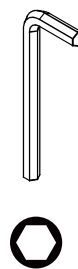



English

WARNING!

1. When installing the product, use a soft surface (such as carpet or cardboard) to avoid scratching or damaging the surface of the product.
2. Please try to use a manual screwdriver instead of electric screw driver. A manual screwdriver can be used to better control the tightness of the screws.
3. Do not use any glue.
4. The product is unstable before it is assembled. Please pay attention to the product installation sequence, and align all screws and screw holes before tightening.
5. The structure of this product can not meet the requirements of children climbing.

Deutsch

ACHTUNG!

1. Verwenden Sie bei der Montage des Produkts eine weiche Unterlage (z. B. Teppich oder Pappe), um Kratzer oder Beschädigungen auf der Oberfläche des Produkts zu vermeiden.
2. Bitte verwenden Sie nach Möglichkeit einen Schraubendreher von Hand anstelle eines elektrischen Schraubendrehers. Mit einem Handschraubendreher lässt sich die Festigkeit der Schrauben besser kontrollieren.
3. Verwenden Sie keinen Klebstoff.
4. Das Produkt ist vor der Montage instabil. Bitte beachten Sie die Montagereihenfolge des Produkts und richten Sie alle Schrauben und Schraublöcher aus, bevor Sie sie festziehen.
5. Die Konstruktion dieses Produkts ist nicht für das Klettern von Kindern ausgelegt.

Español

ADVERTENCIA!

1. Al instalar el producto, utilice una superficie blanda (como alfombra o cartón) para evitar rayar o dañar la superficie del producto.
2. Utilice preferentemente un destornillador manual en lugar de uno eléctrico. Un destornillador manual permite controlar mejor el apriete de los tornillos.
3. No utilice ningún tipo de pegamento.
4. El producto es inestable antes de ser montado. Preste atención a la secuencia de instalación del producto y alinee todos los tornillos y agujeros antes de apretarlos.
5. La estructura de este producto no está diseñada para que los niños trepen por él.

Français

ATTENTION!

1. Lors de l'installation du produit, utilisez une surface molle (comme un tapis ou du carton) pour éviter de rayer ou d'endommager la surface du produit.
2. Veuillez essayer d'utiliser un tournevis manuel plutôt qu'un tournevis électrique. Un tournevis manuel permet de mieux contrôler le serrage des vis.
3. N'utilisez aucune colle.
4. Le produit est instable avant son assemblage. Veuillez respecter l'ordre d'installation du produit et alignez toutes les vis et tous les trous avant de serrer.
5. La structure de ce produit n'est pas conçue pour supporter que des enfants grimpent dessus.

Italiano

AVVERTENZA!

1. Durante l'installazione del prodotto, utilizzare una superficie morbida (come un tappeto o del cartone) per evitare di graffiare o danneggiare la superficie del prodotto.
2. Si prega di utilizzare un cacciavite manuale invece di un cacciavite elettrico. Un cacciavite manuale permette di controllare meglio la tensione delle viti.
3. Non utilizzare alcun tipo di colla.
4. Il prodotto è instabile prima del montaggio. Prestare attenzione alla sequenza di installazione del prodotto e allineare tutte le viti e i fori delle viti prima di serrarli.
5. La struttura di questo prodotto non è adatta per sopportare il peso di bambini che ci si arrampicano.

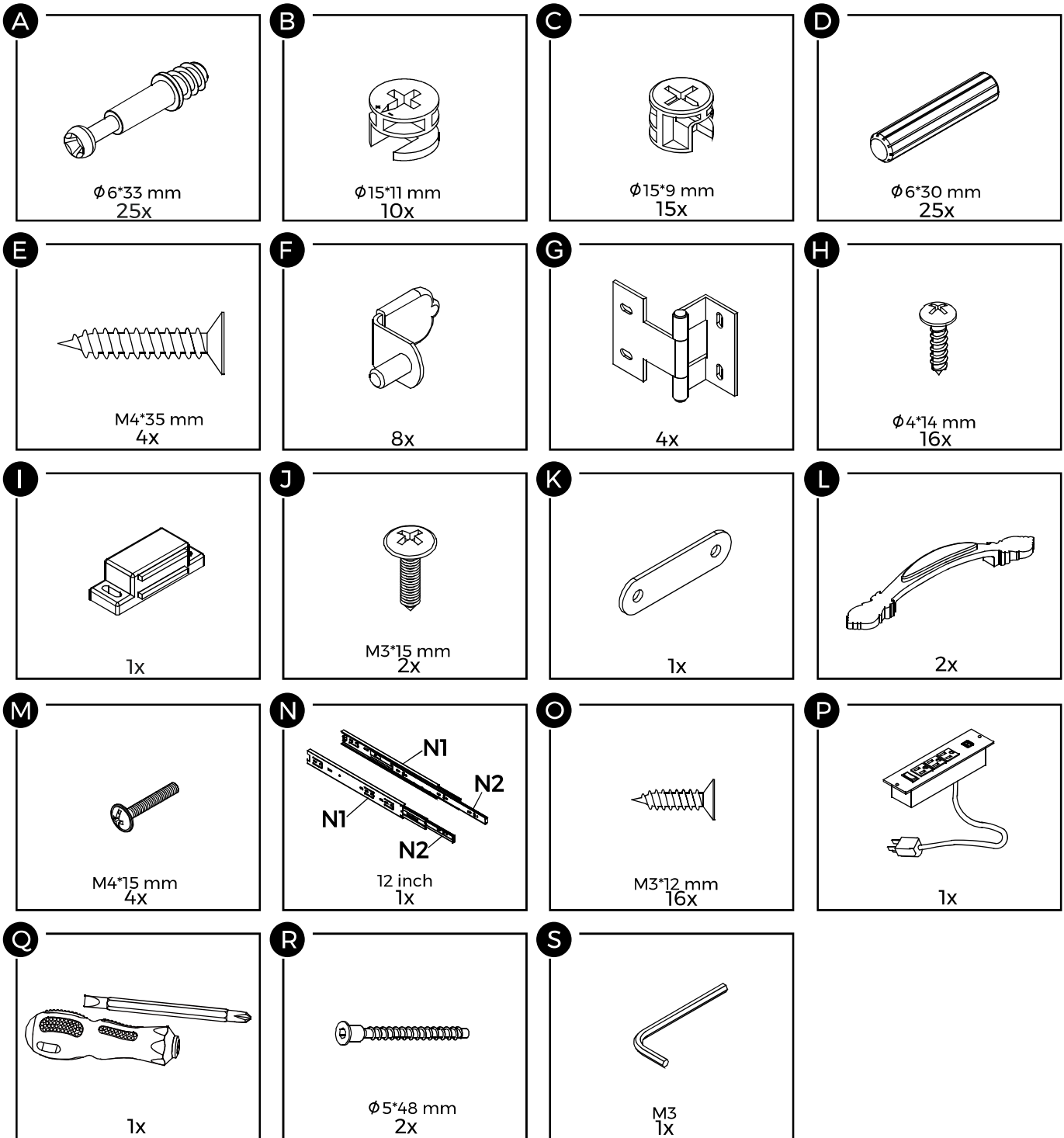

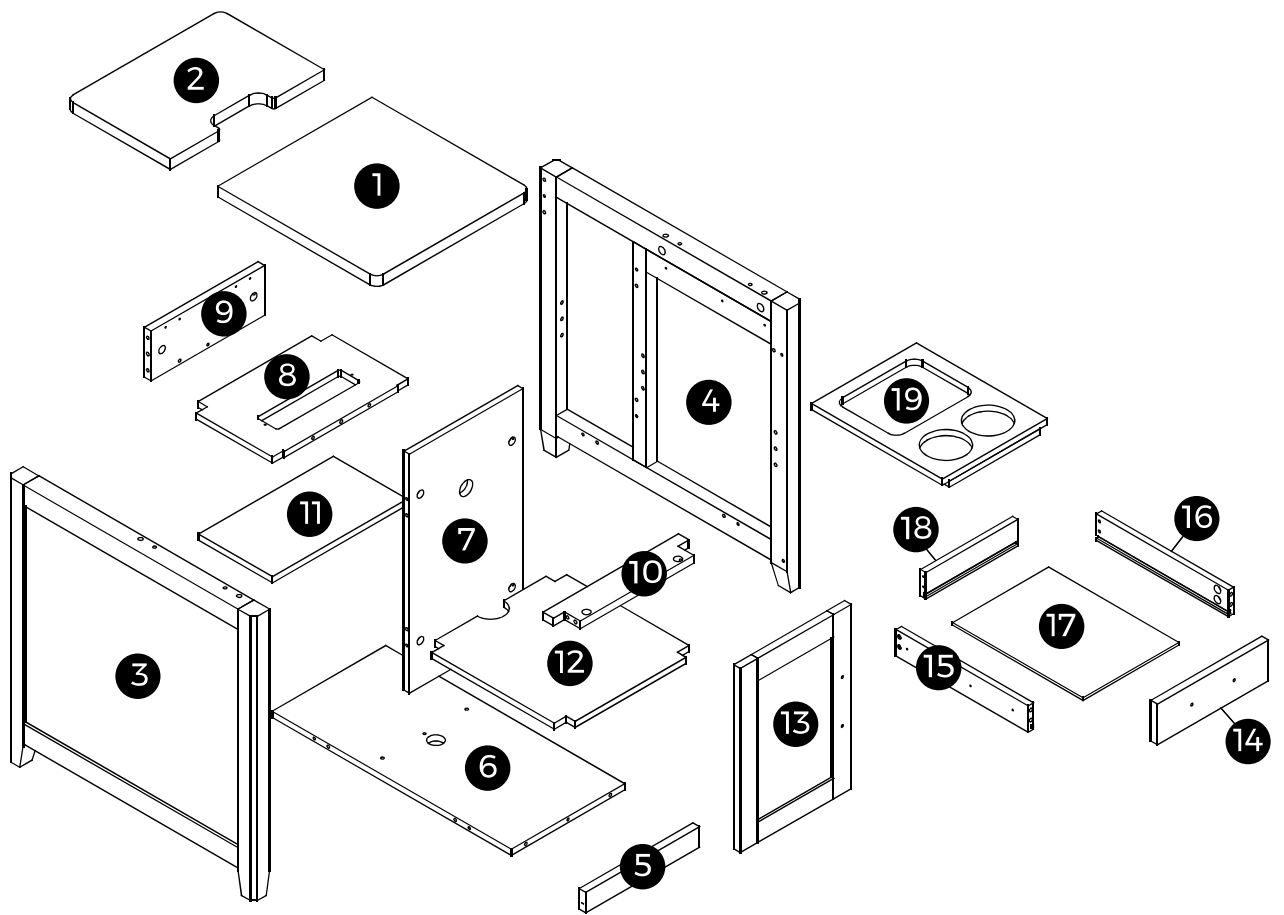

1

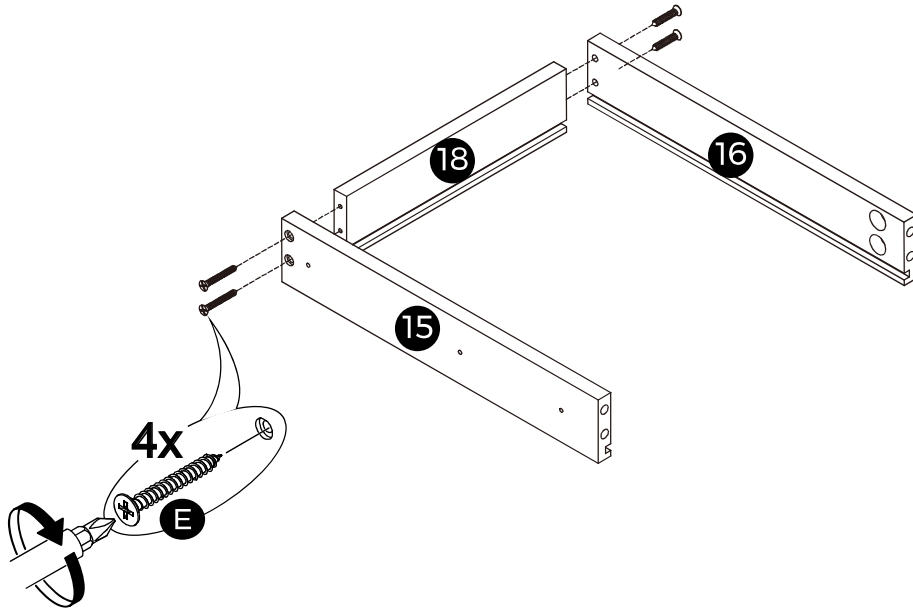

2

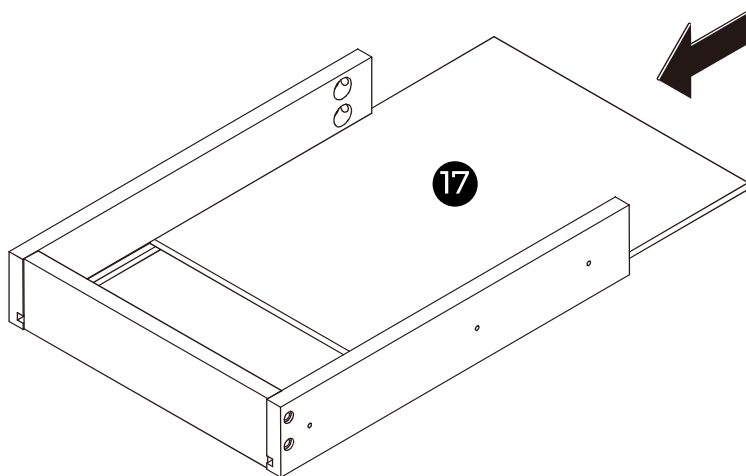

3

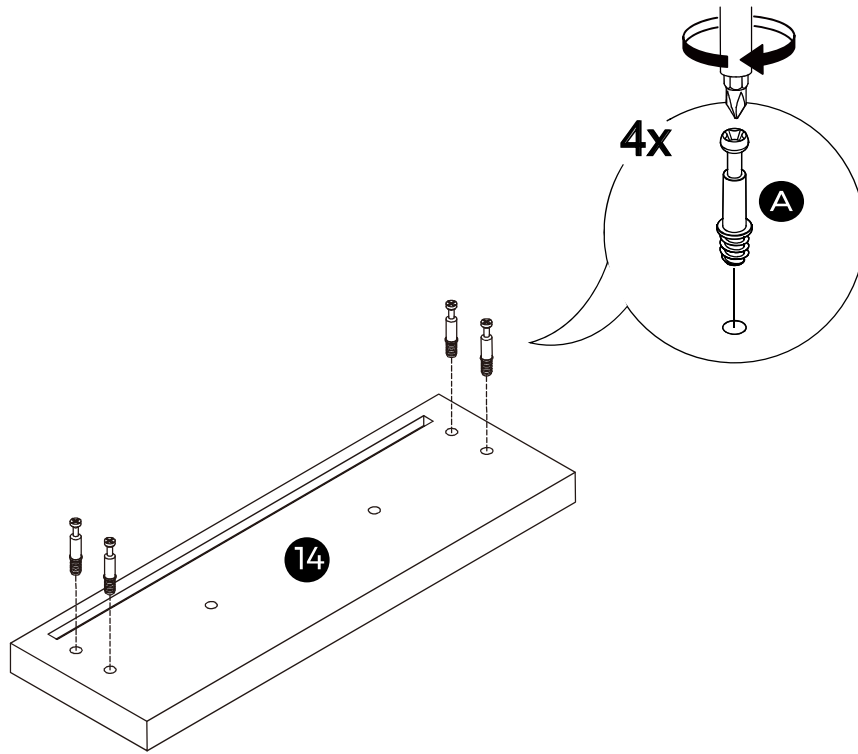

4

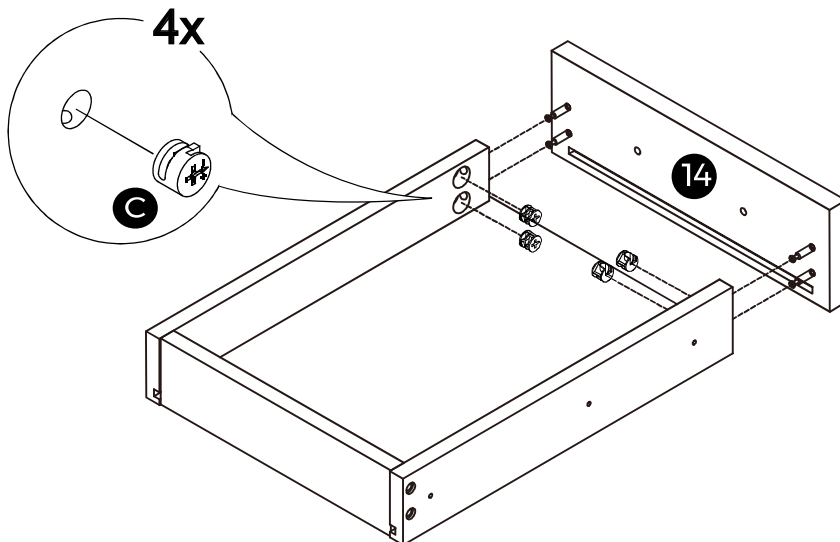
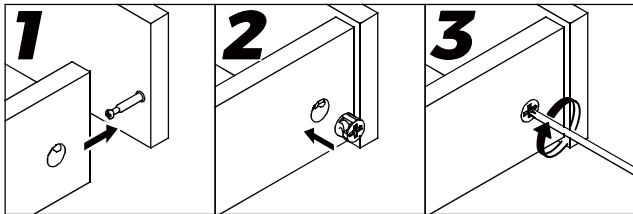

5

Three-section slide rail Split Diagram

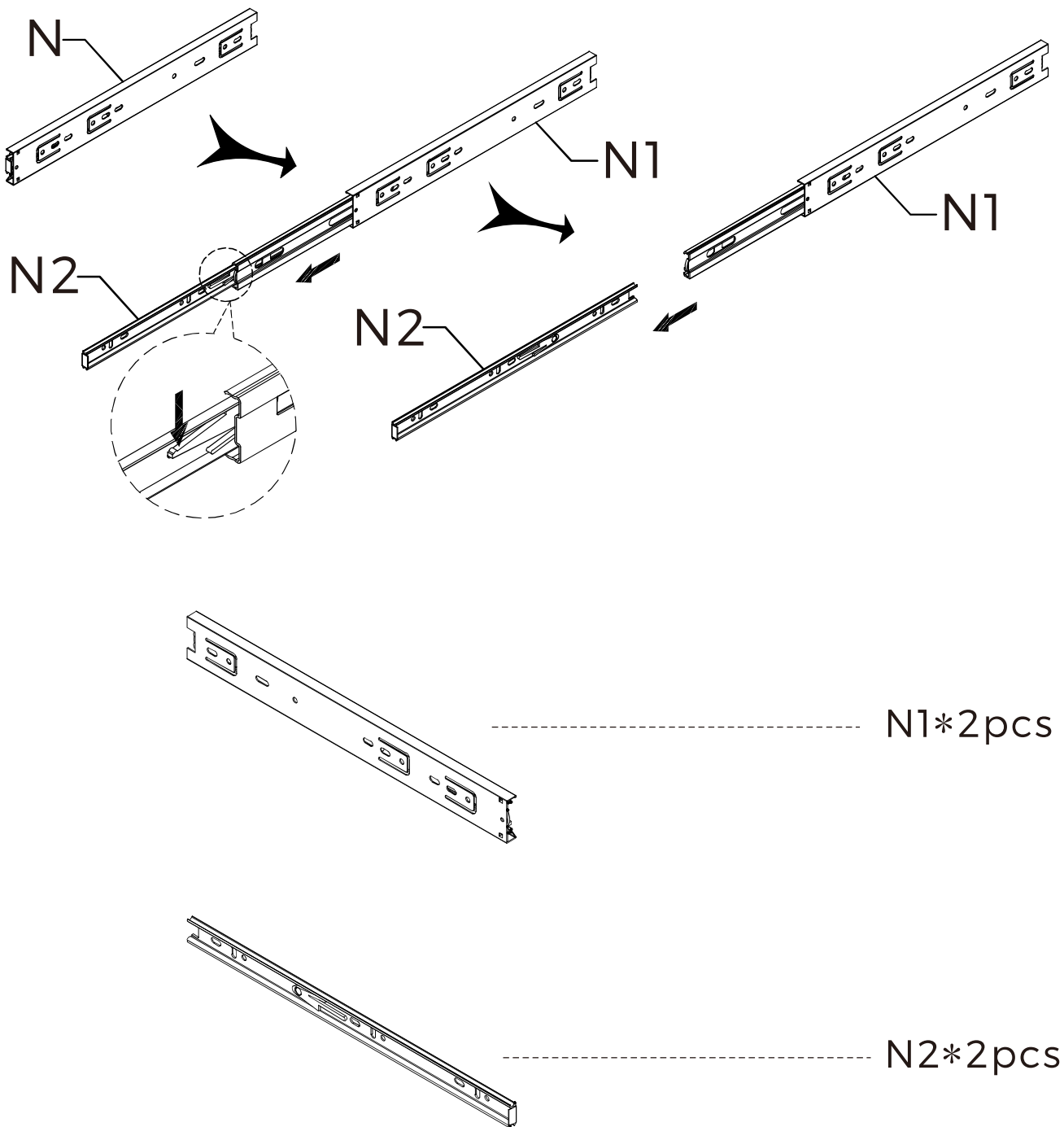

6

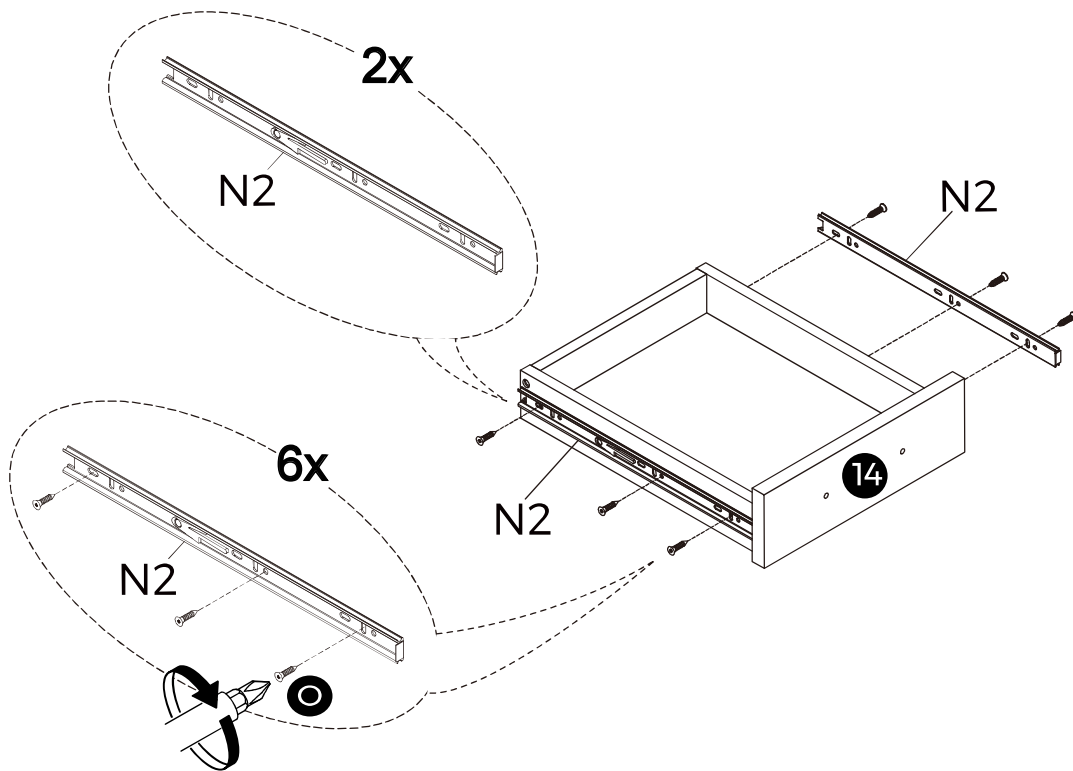

7

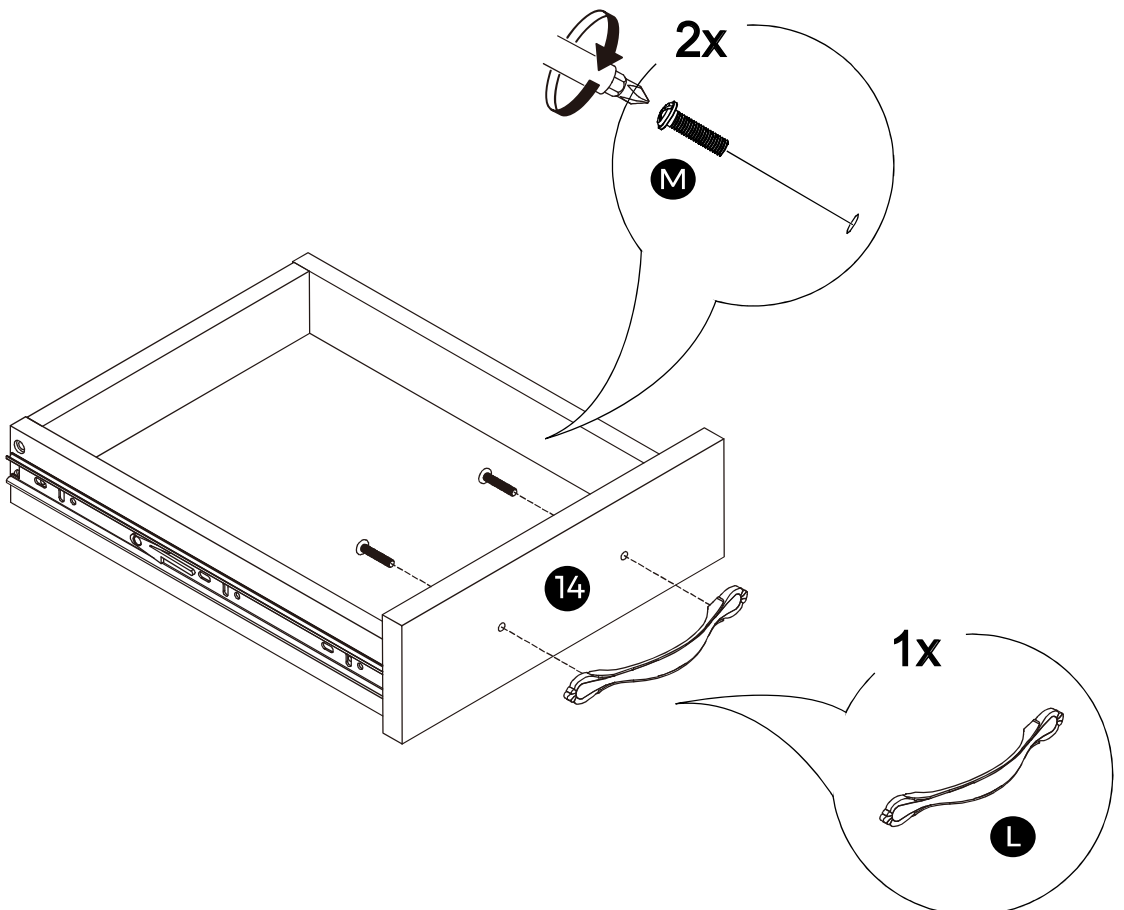

8

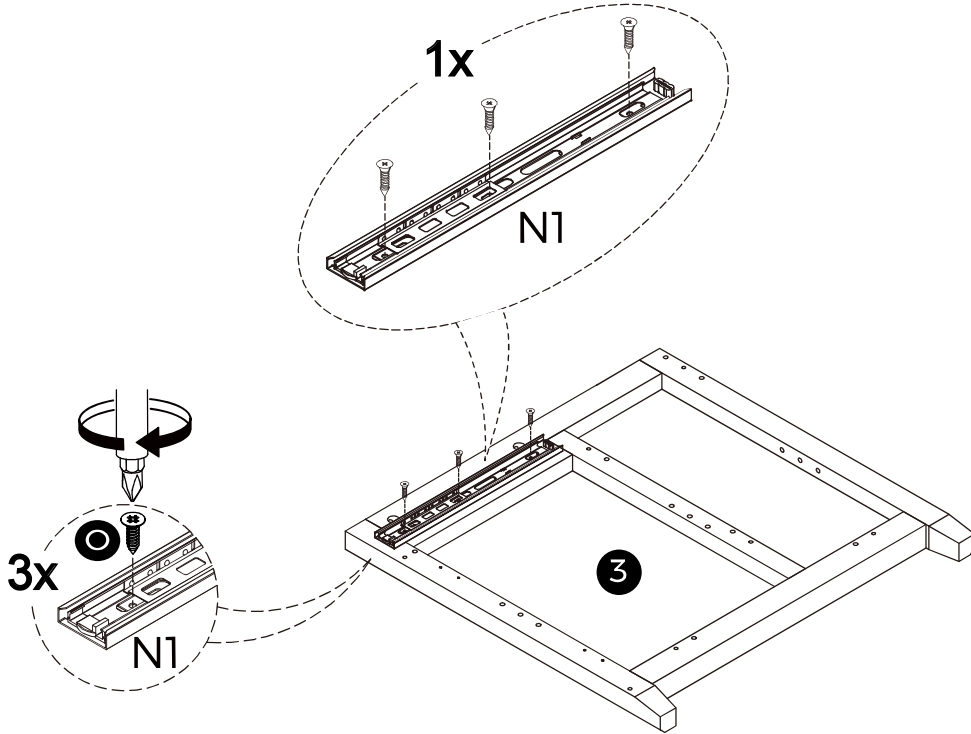

9

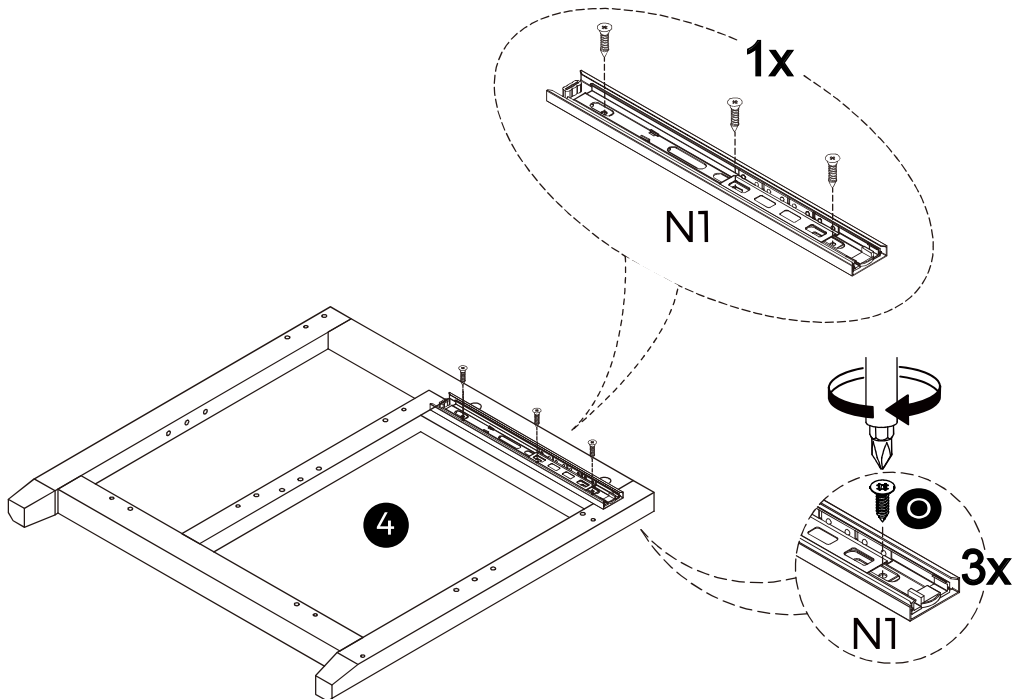

10

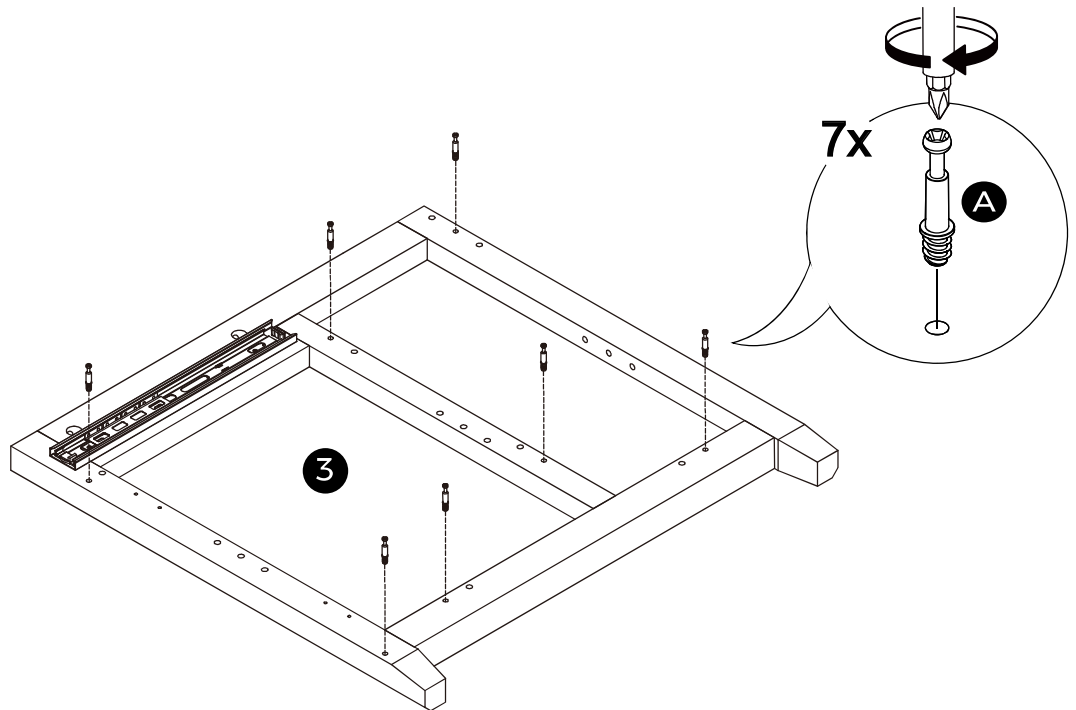

11

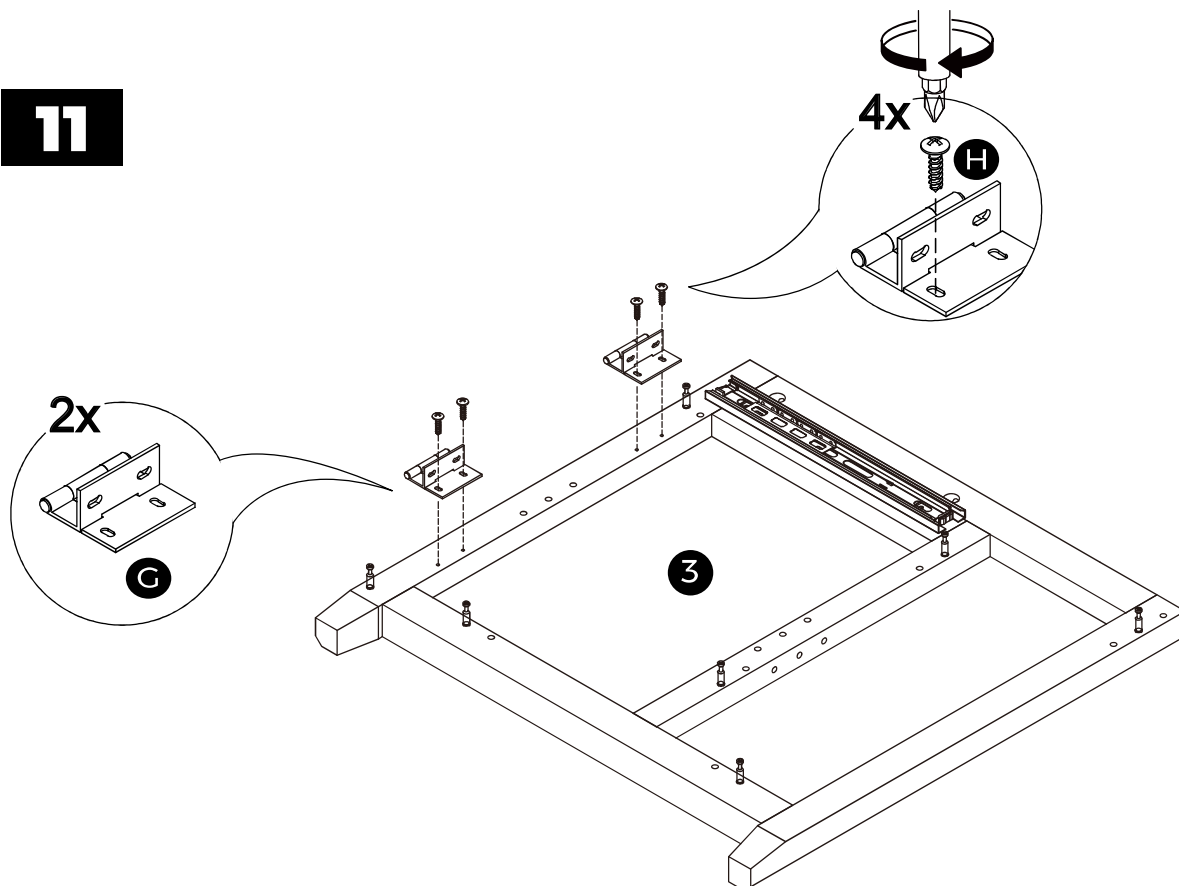

14

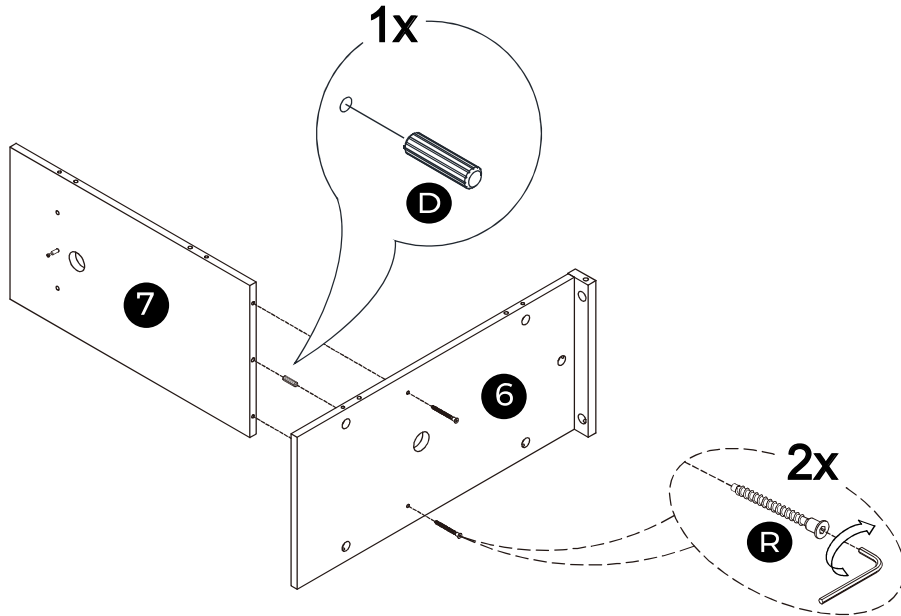

15

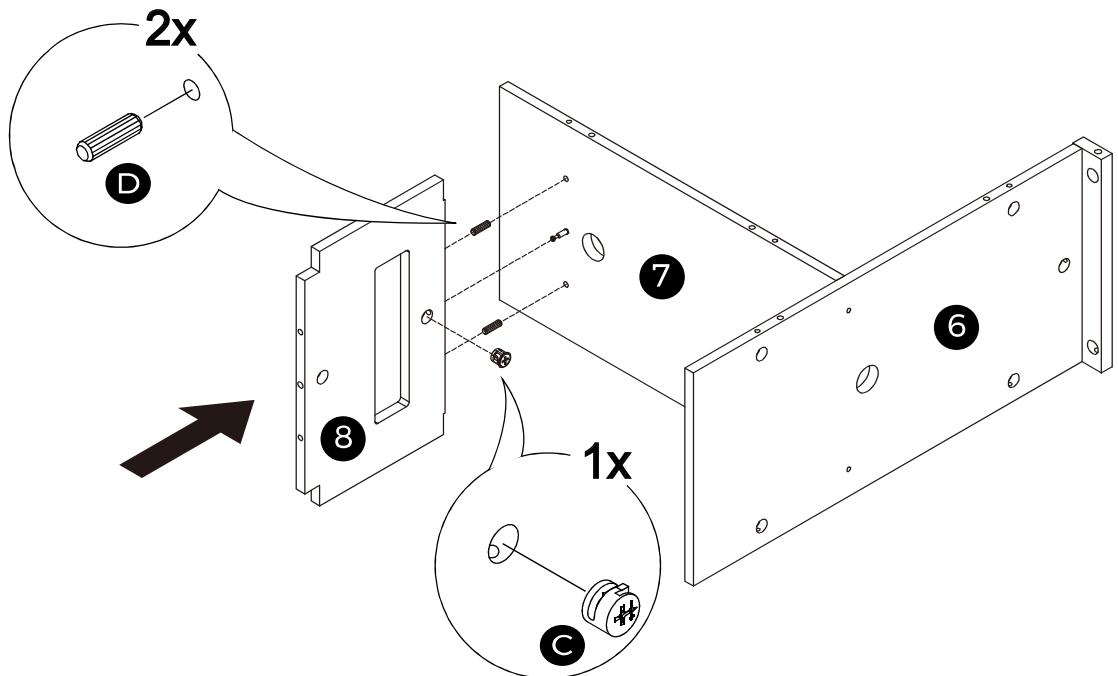
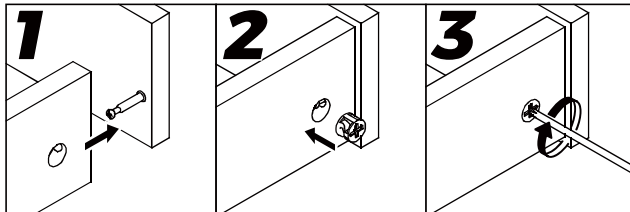

16

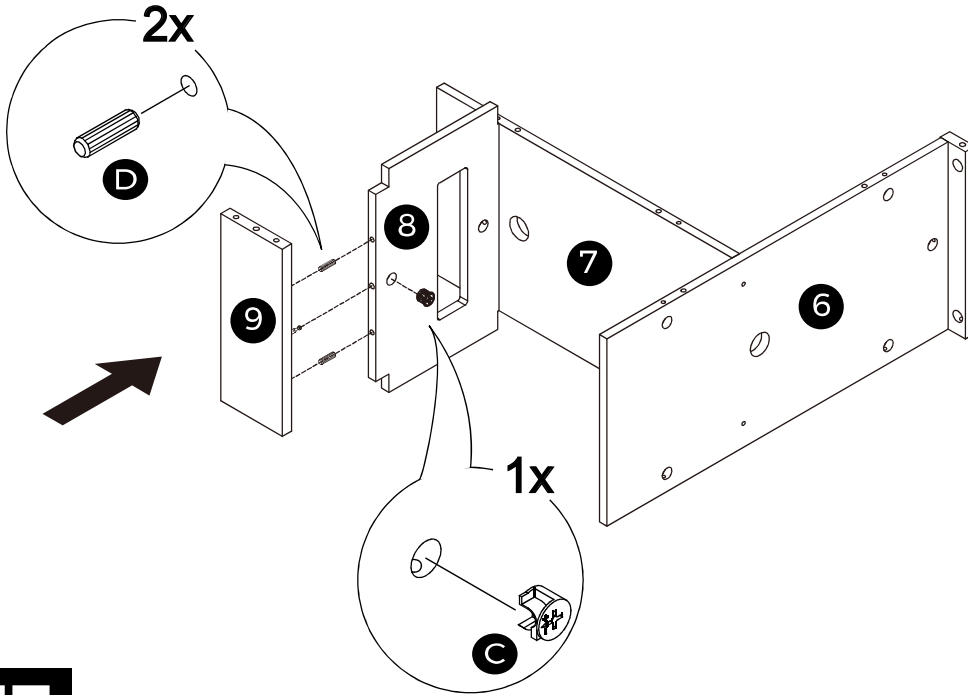
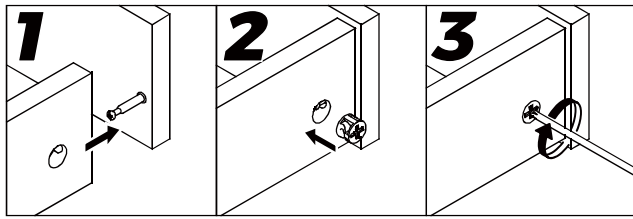

17

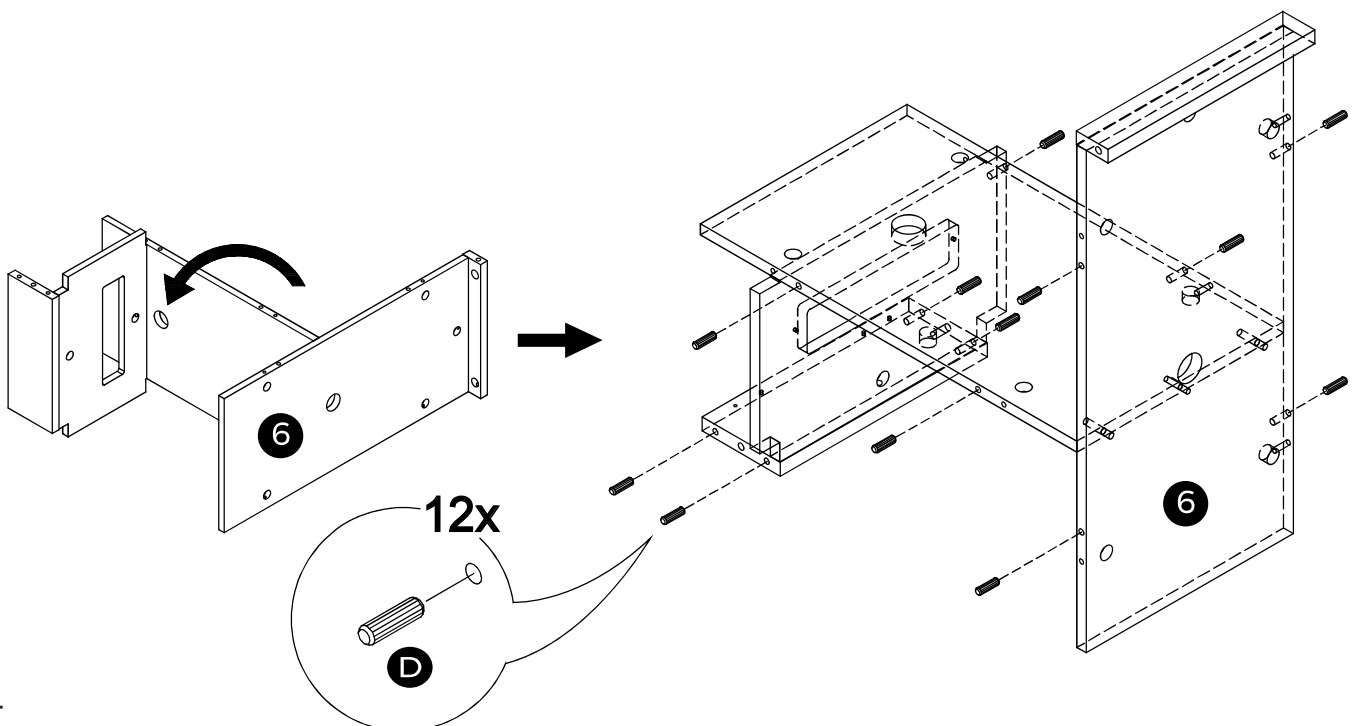

18

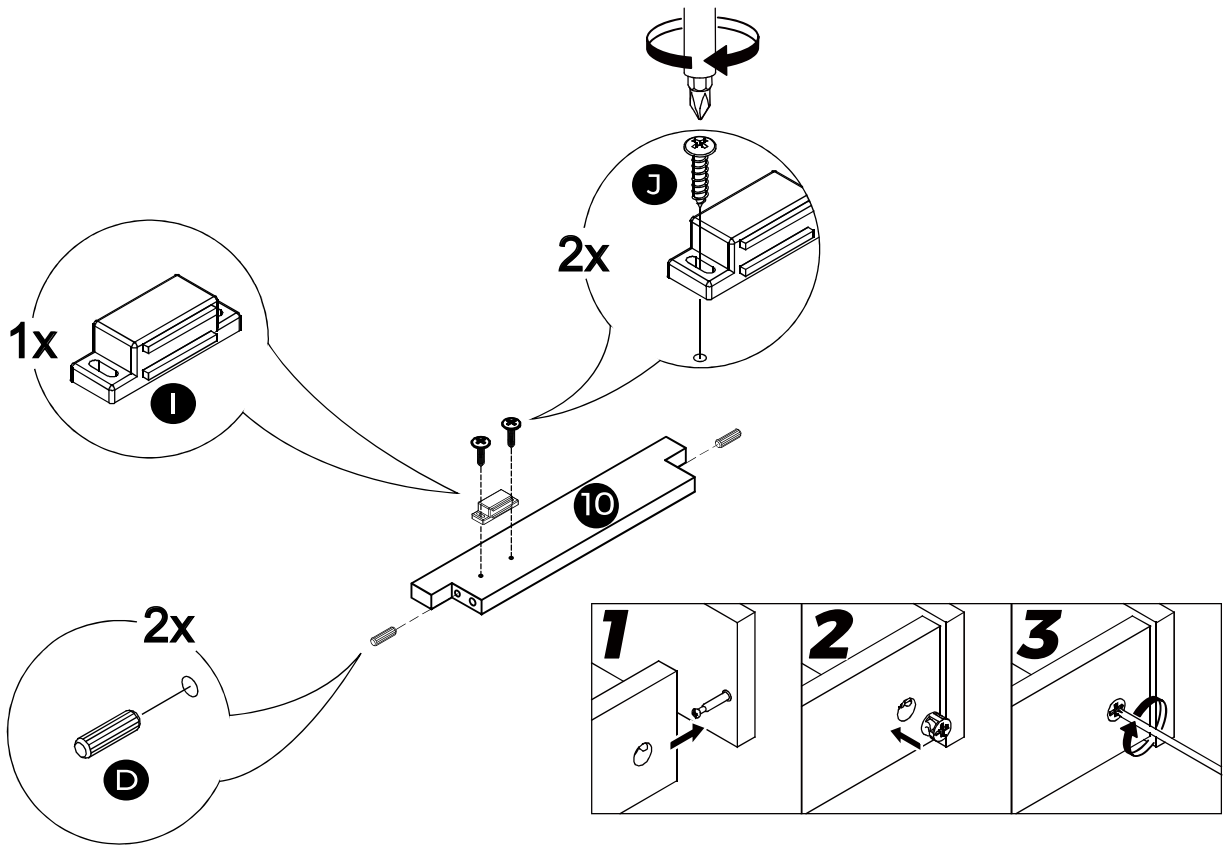

19

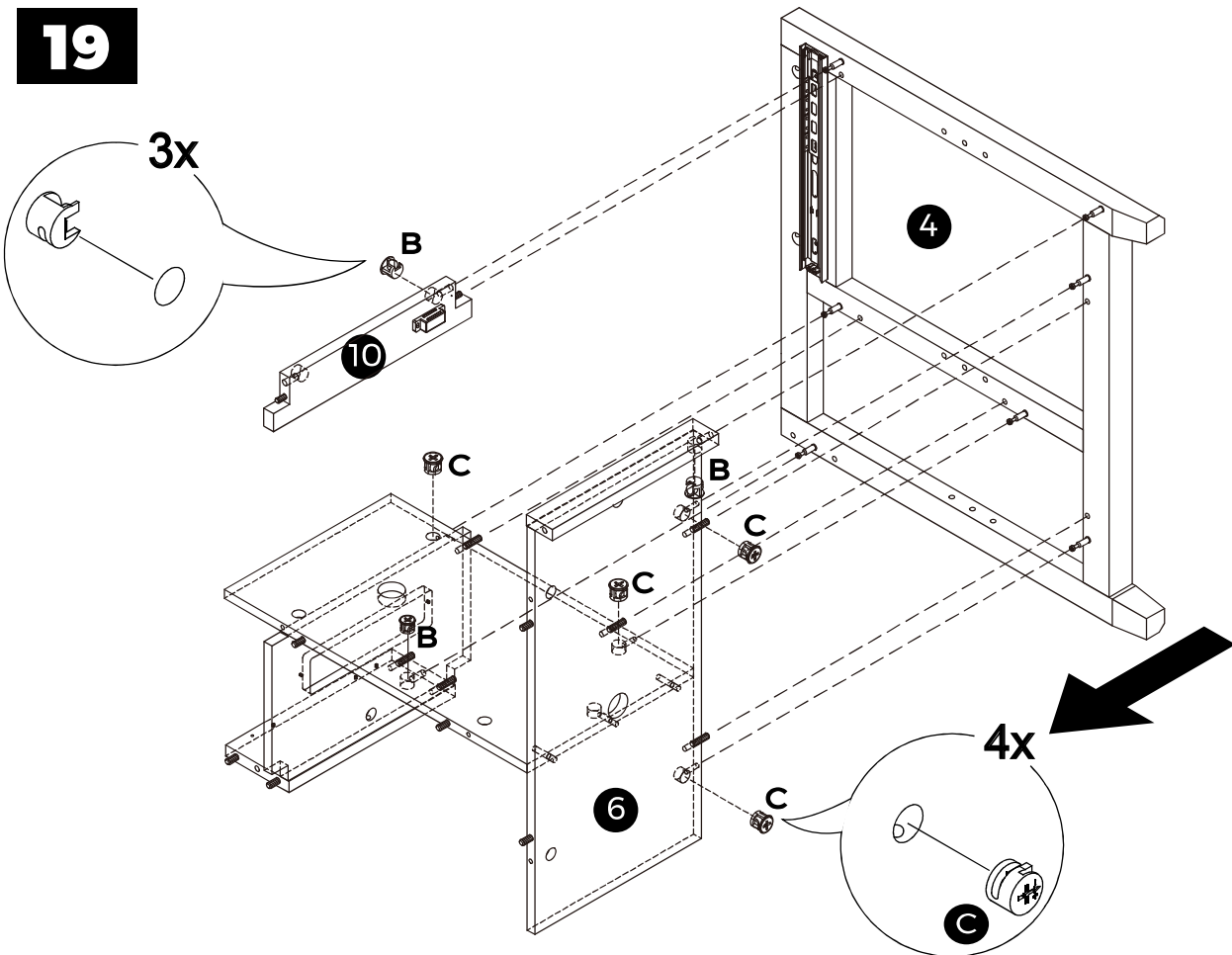

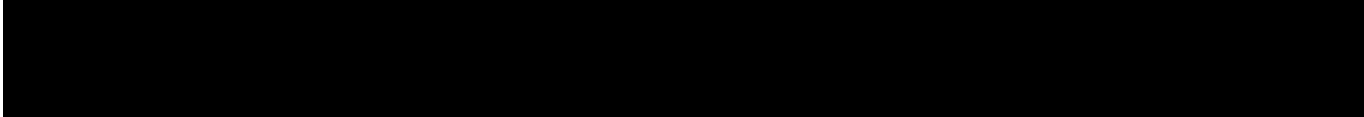

20

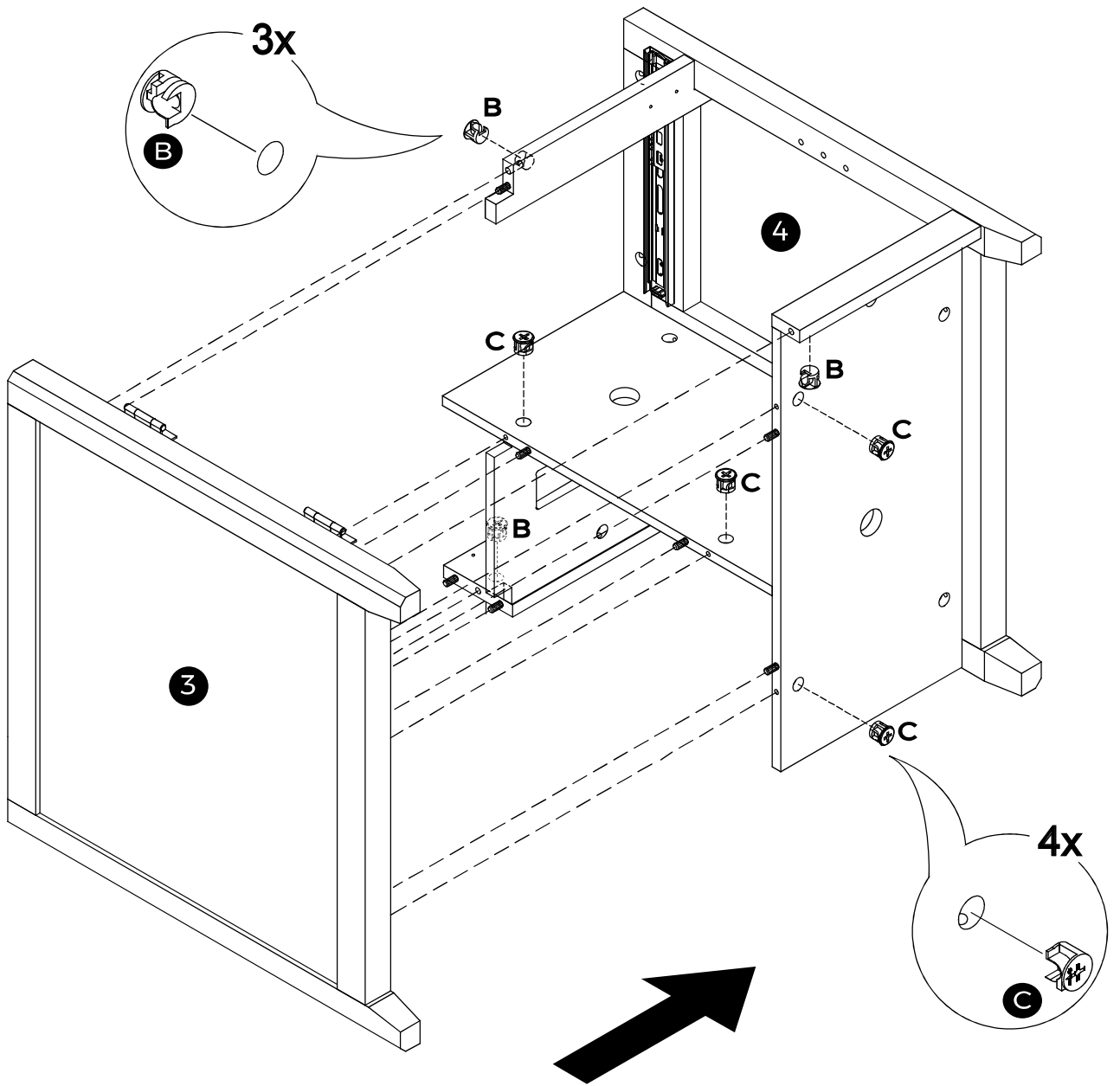
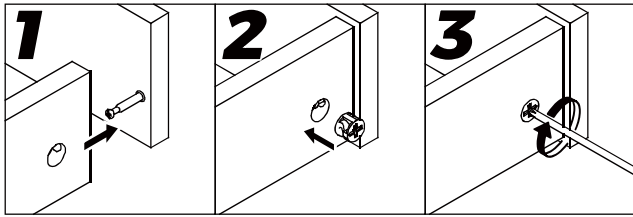

21

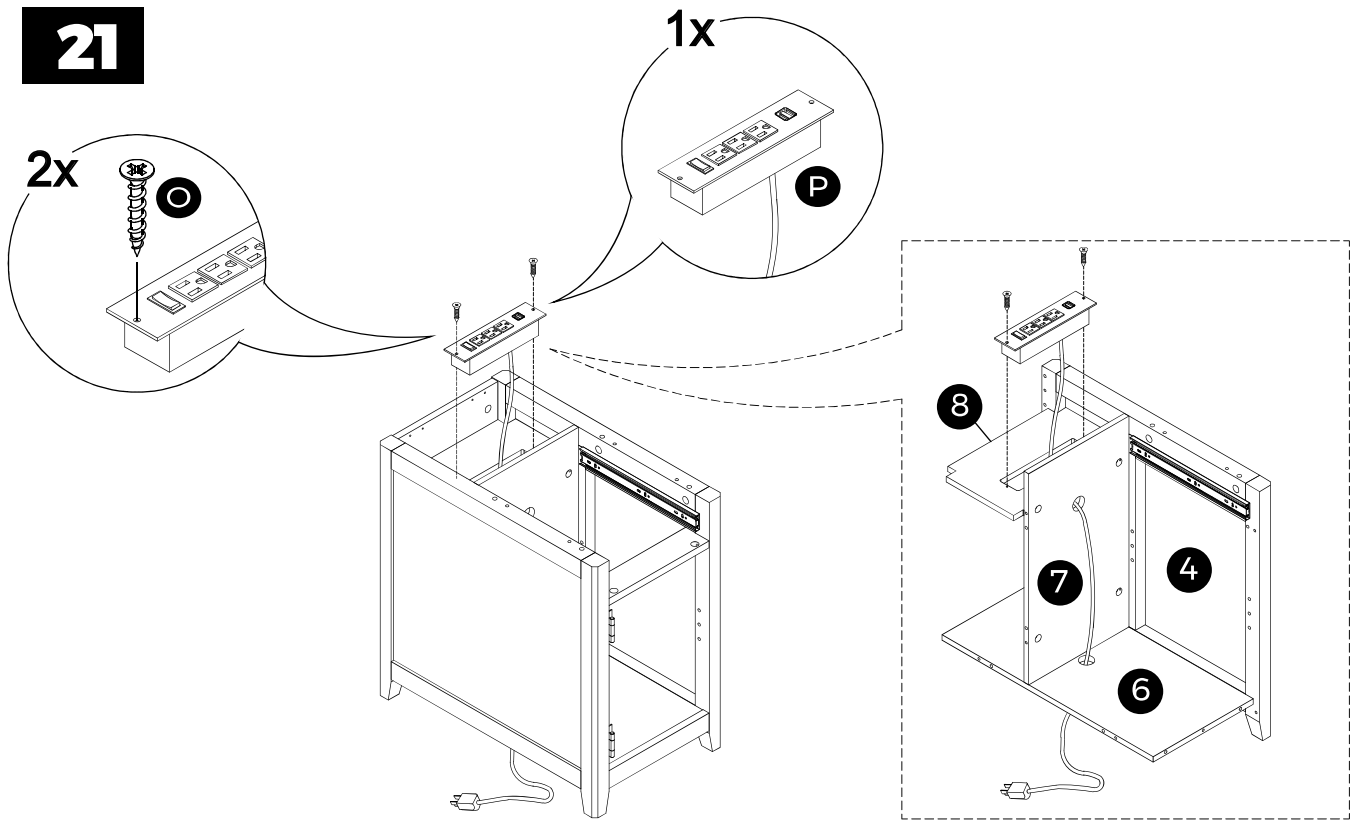

Installation diagram of socket

22

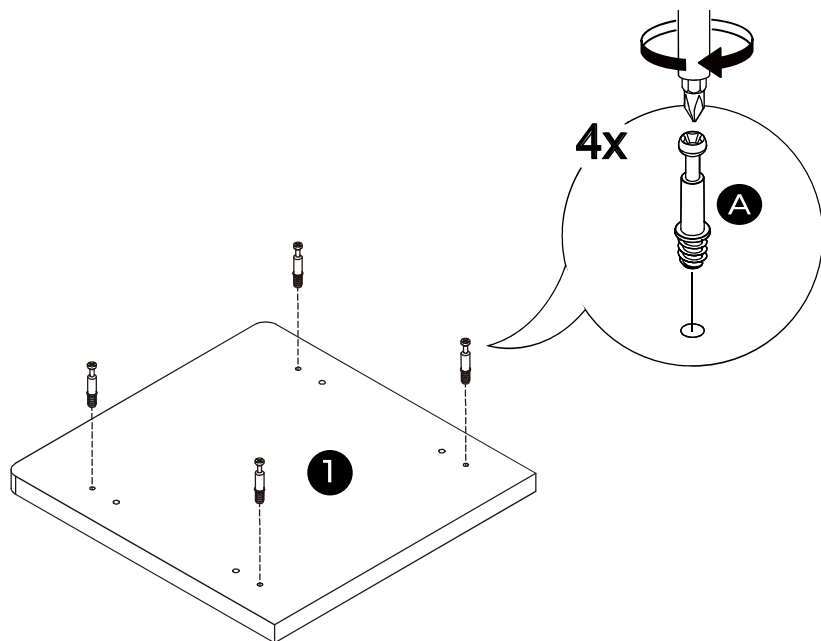

23

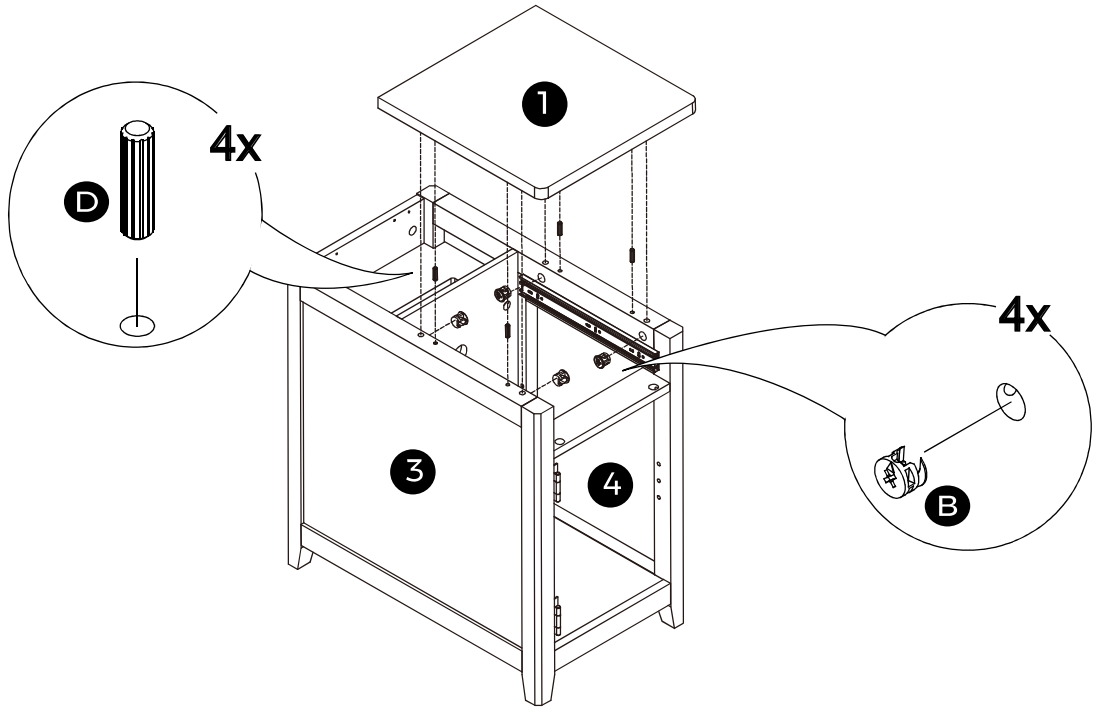
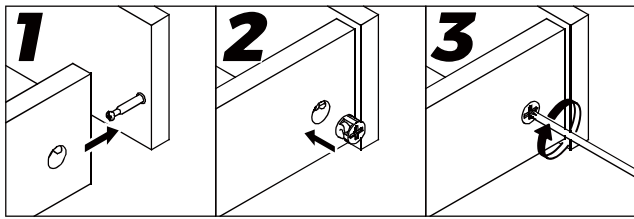

24

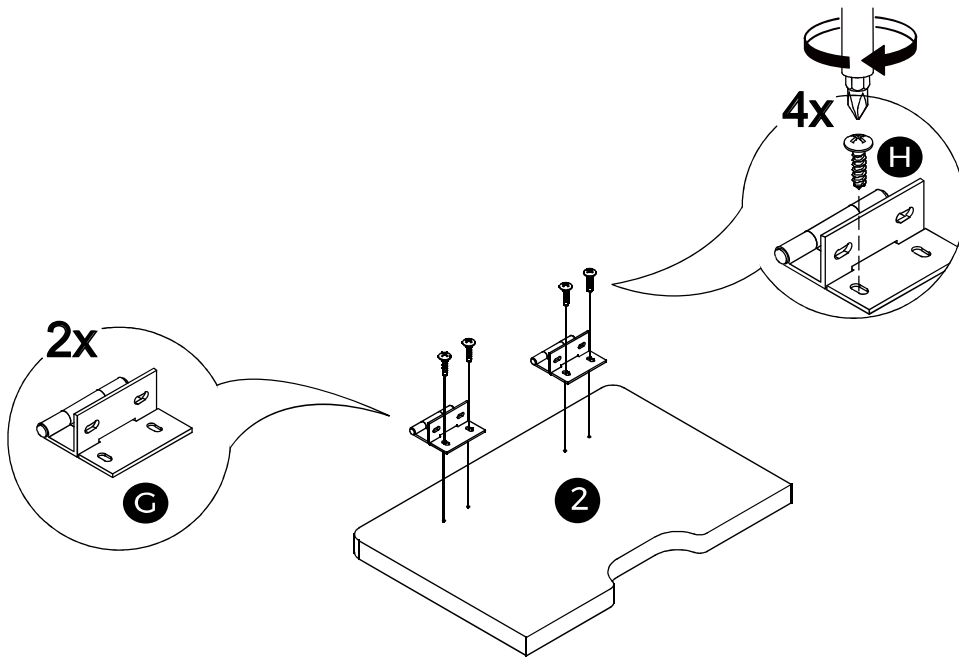

25

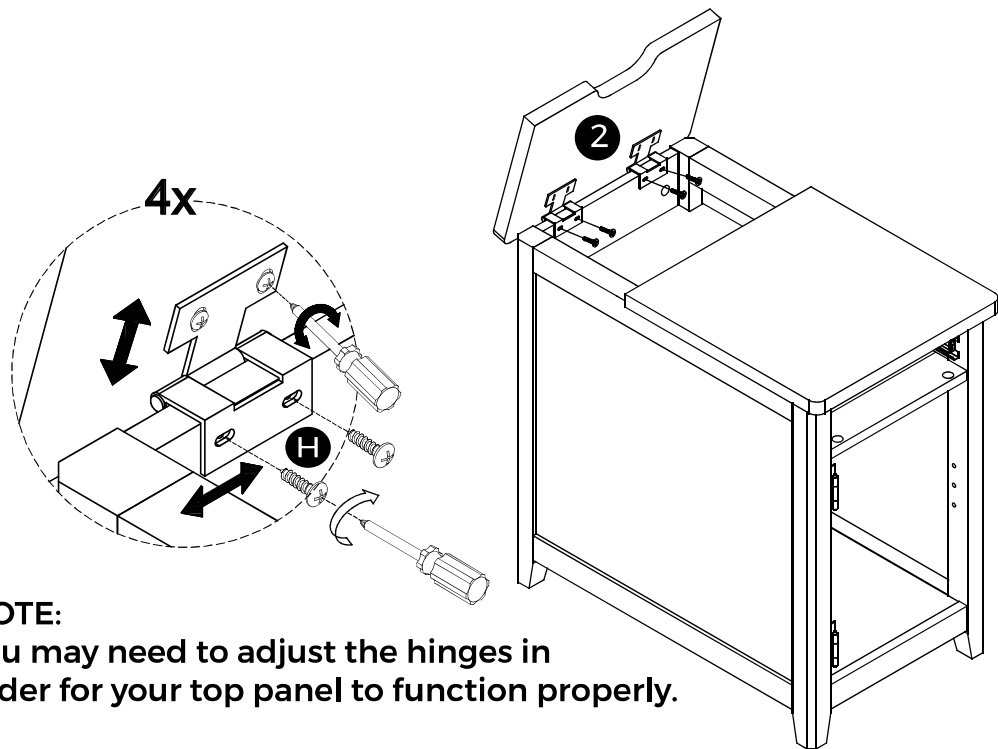

NOTE:
you may need to adjust the hinges in order for your top panel to function properly.

26

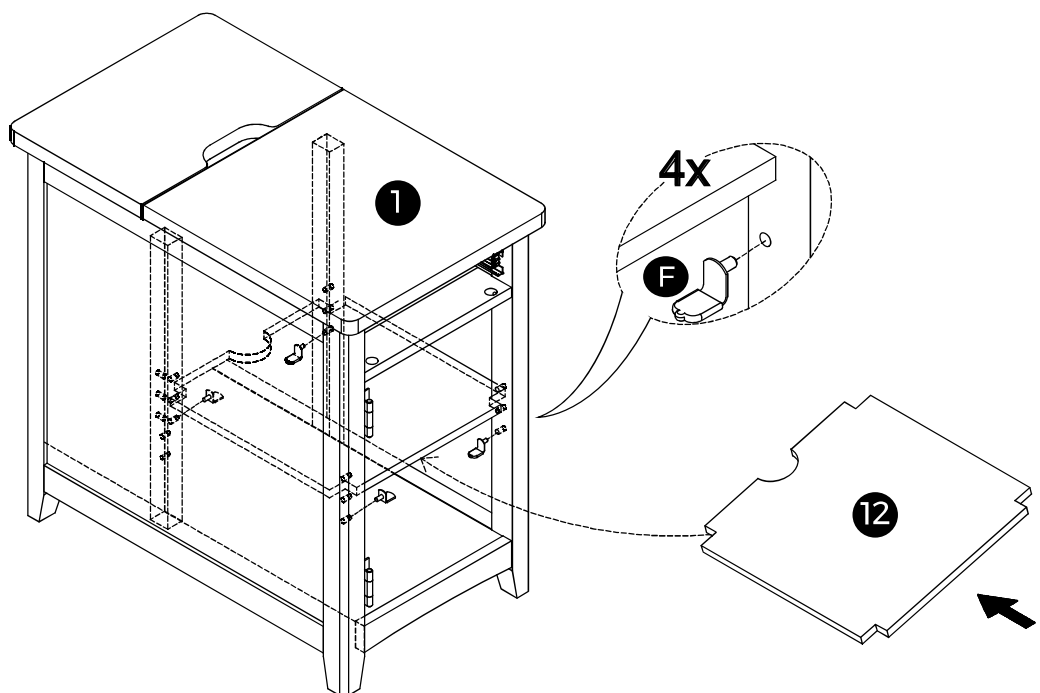

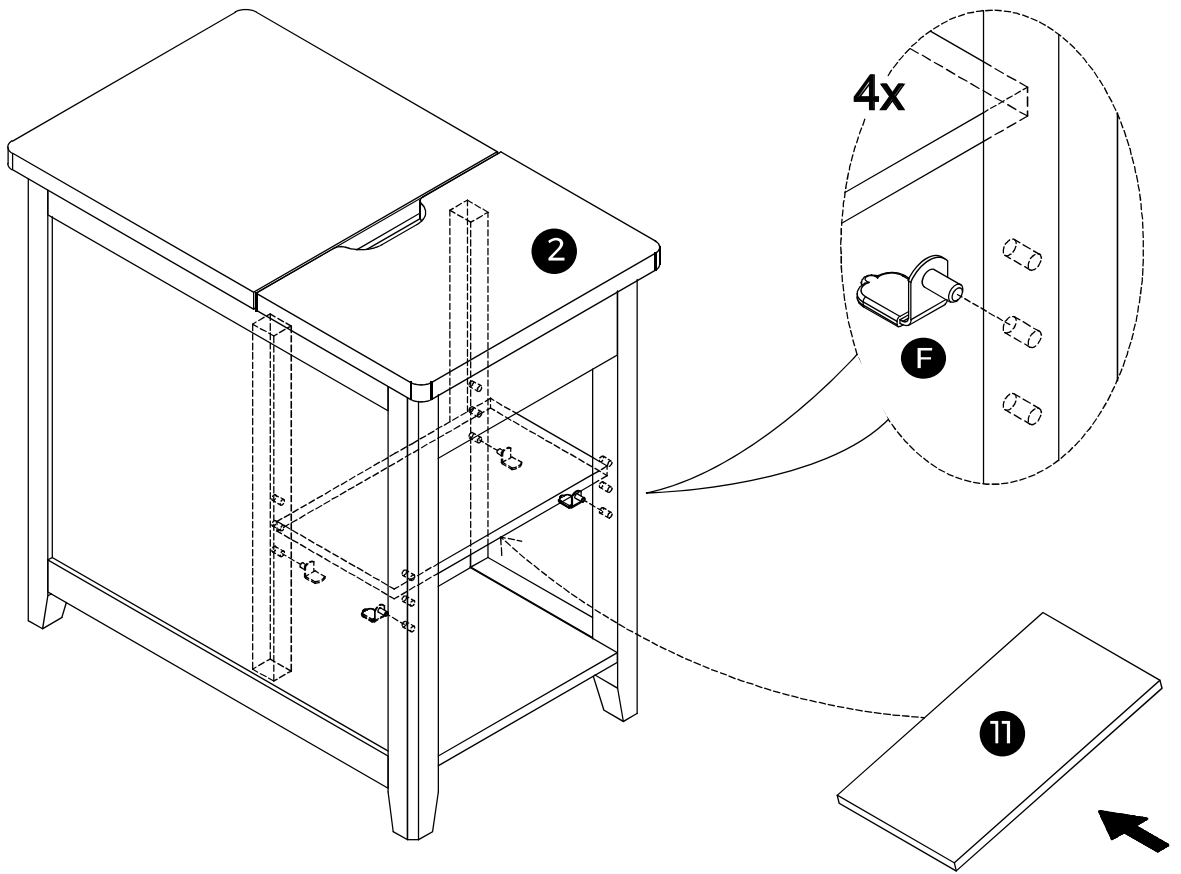

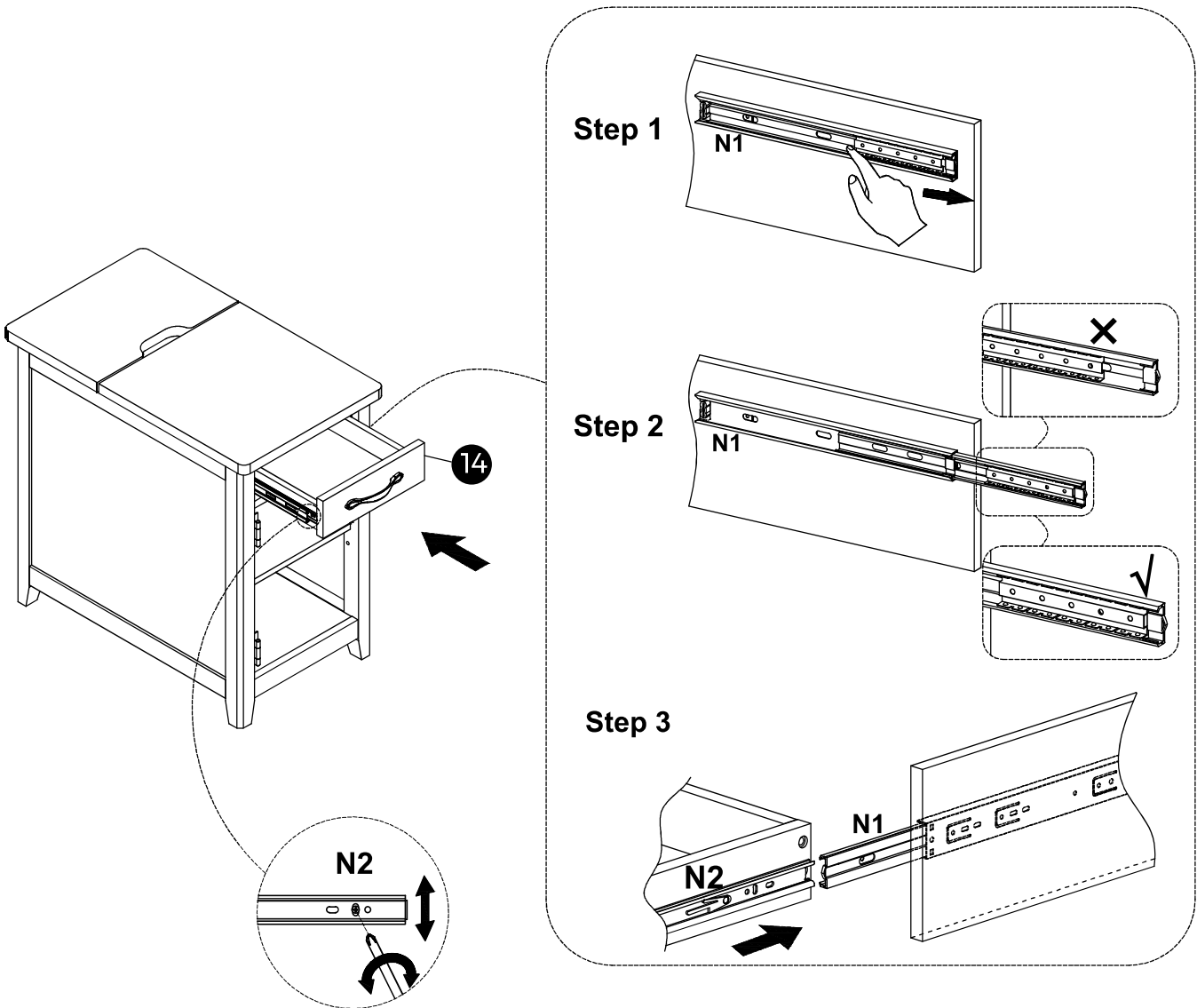

After installing the part of "N", the drawer slide, you may need to adjust the screw in order for the drawer to function properly.

29

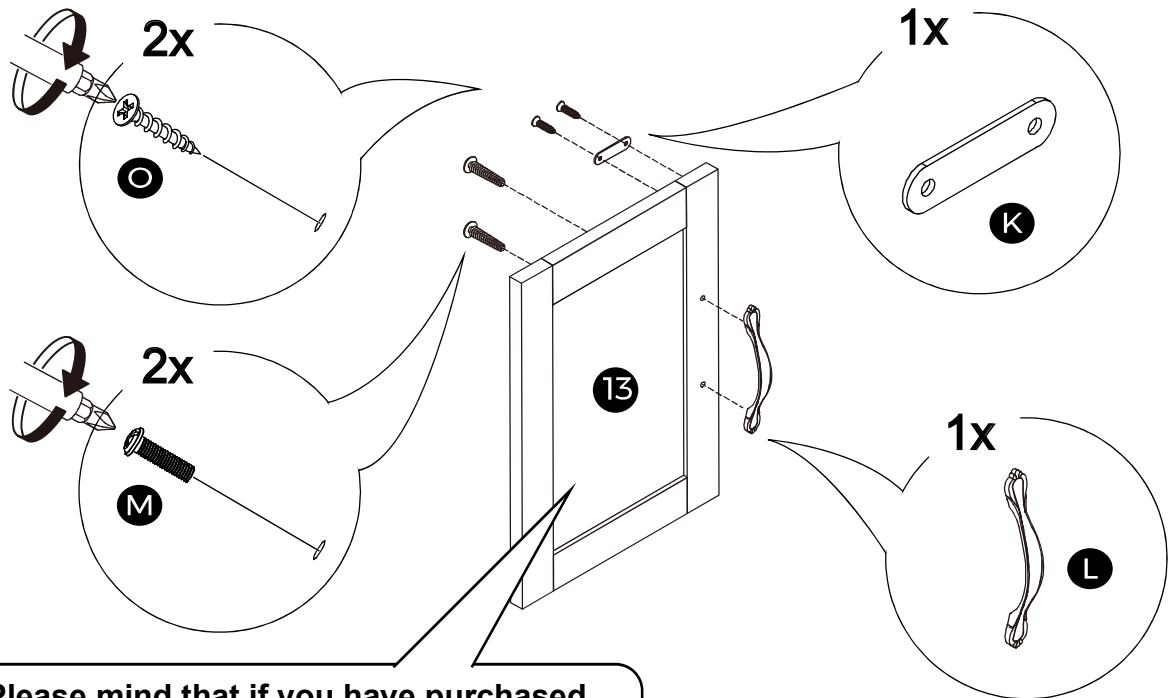

i Please mind that if you have purchased a glass door style, then this will be a glass door. Please handle it with care to avoid damaging the glass.

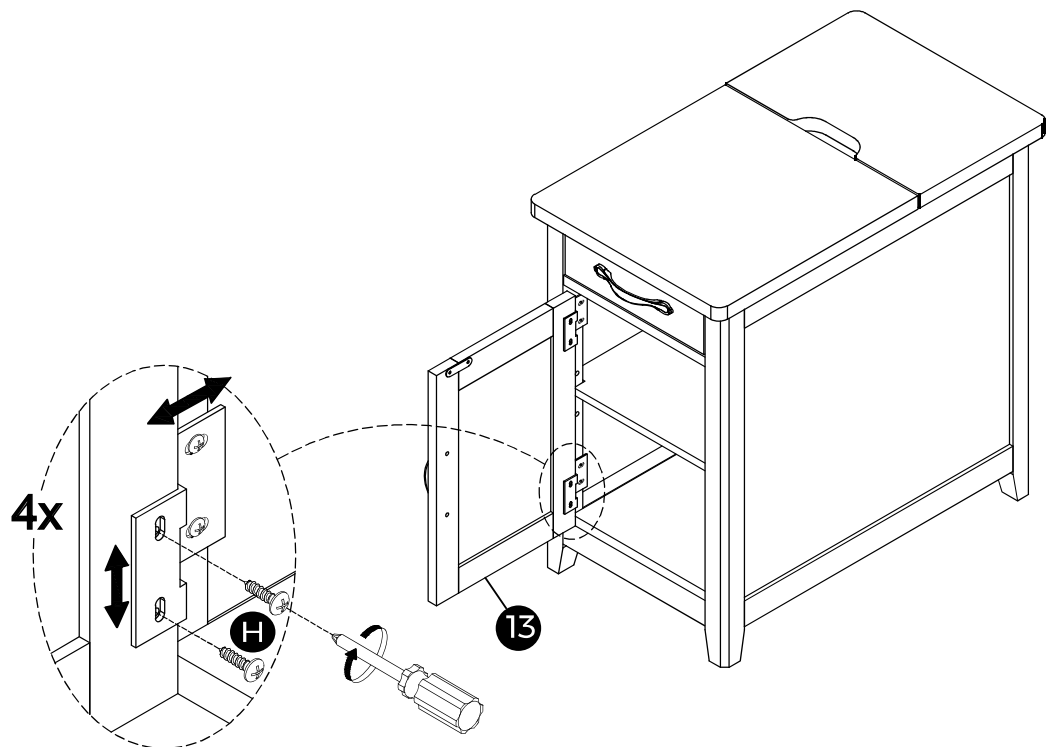

NOTE:
you may need to adjust the hinges in order for your door to function properly.

30

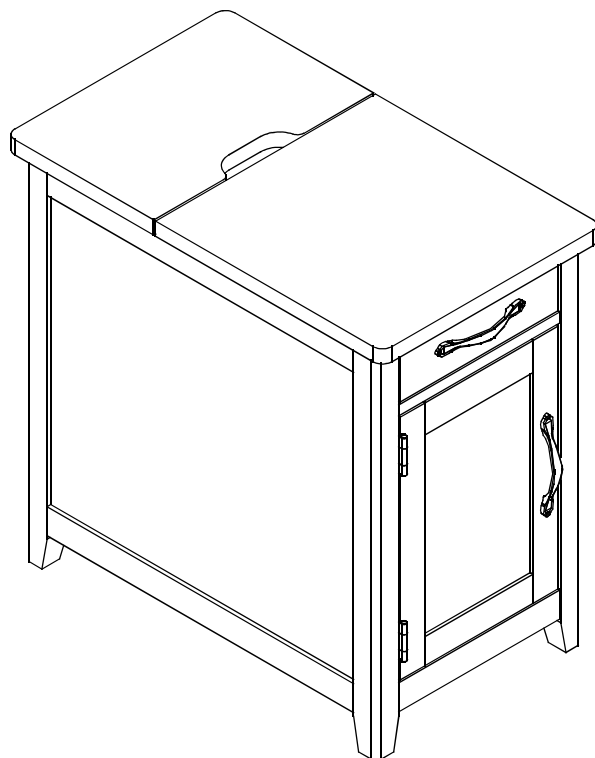
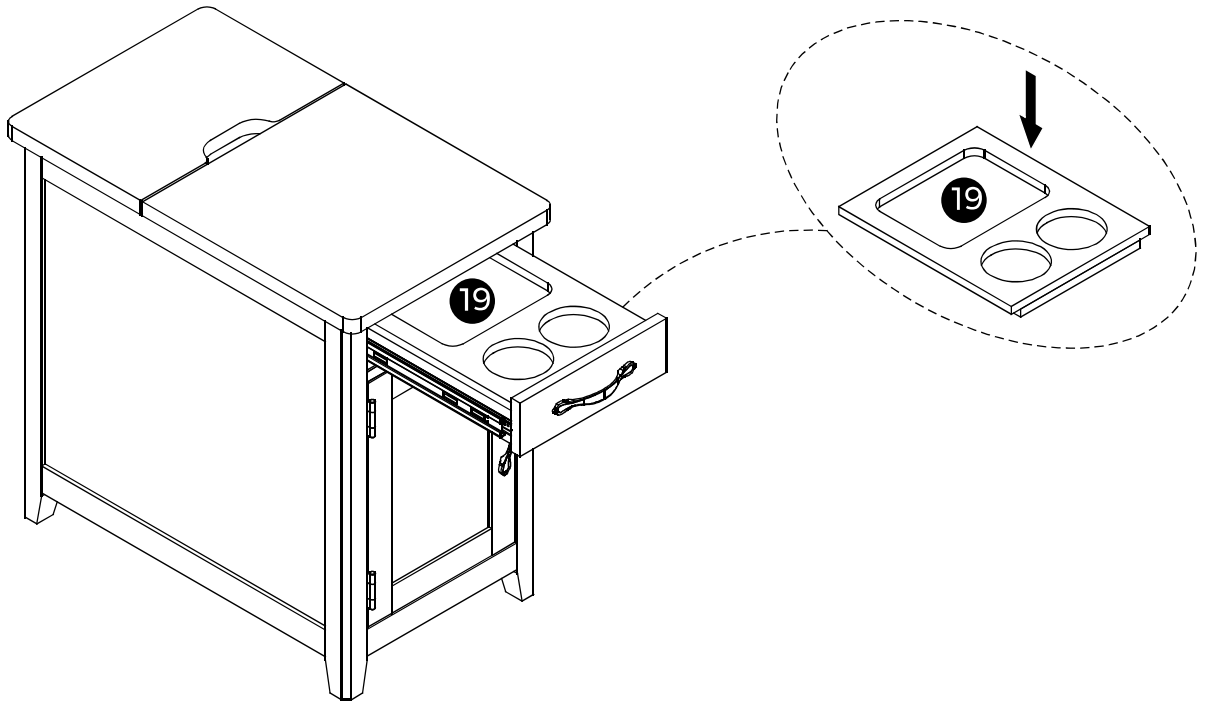

Dear Valued Customer,

Thank you for bringing our products into your life.
Your happiness and satisfaction are at the heart of what we do.
If our products have brightened your day, we're thrilled and eager to share that light further.

Encountering an issue? We're here to help swiftly and effectively.

Share Details

Provide your order number and a photo of the issue, along with a brief description.

Await Solutions

Our team will quickly review and propose the right after-sales solution to make things right.

Your feedback propels us forward.
We're committed to ensuring your purchase experience is always positive.

Warmest thanks,
Customer Service Team