

Assembly Instruction

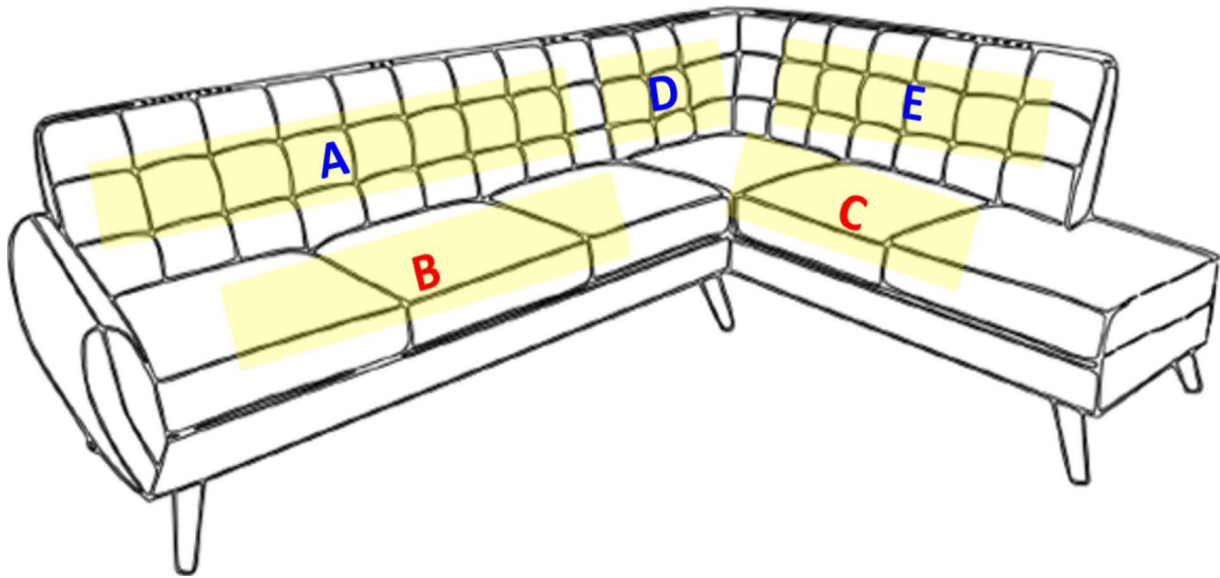

PART LIST

BOX 1:

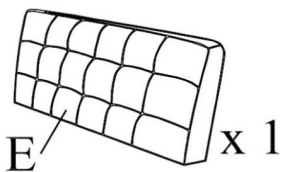
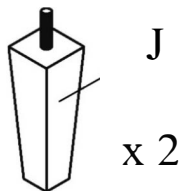
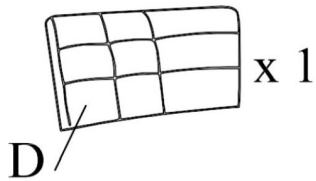
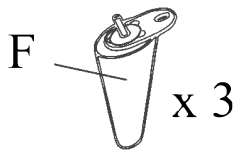
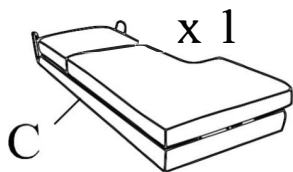

BOX 2:

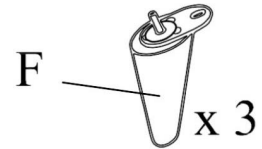
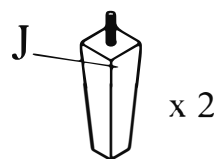
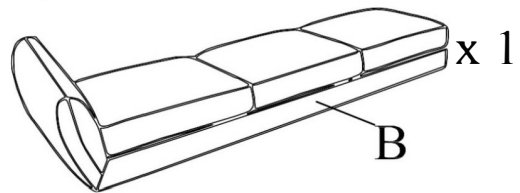
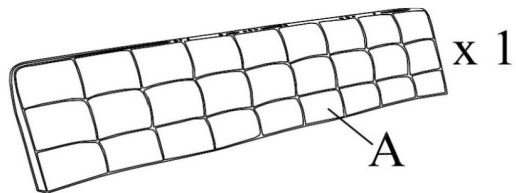

HARDWARE LIST



②



③



Bolt 5/16" * 30mm

Lock Washer Ø5/16"

Flat Washer Ø5/16"

Allen Wrench M4

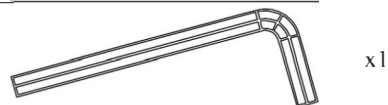



Please follow the drawings below to assemble this item.

Step 1. Take out the legs from the inner box, and then rotate / tighten into the position at bottom of the left - facing sofa and the matching right - facing chaise as shown in below drawings.

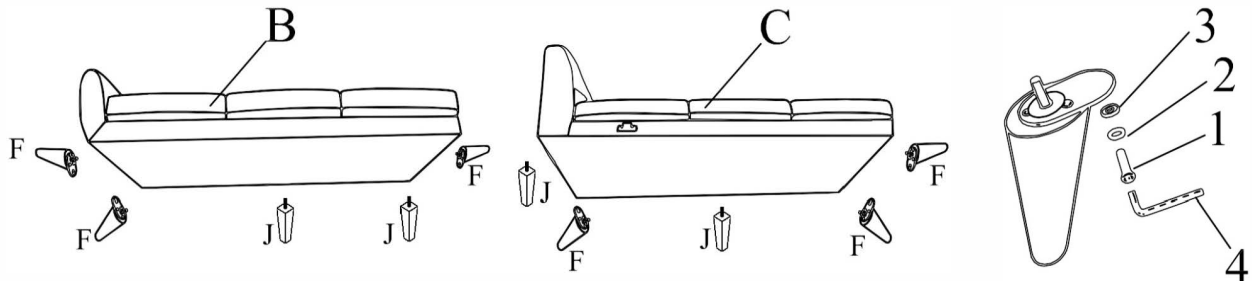

Step 2. Allign female brackets with the male one at the back & seat. And then insert / push the whole backrest to the seat. Make sure the brackets are secured in position before using.

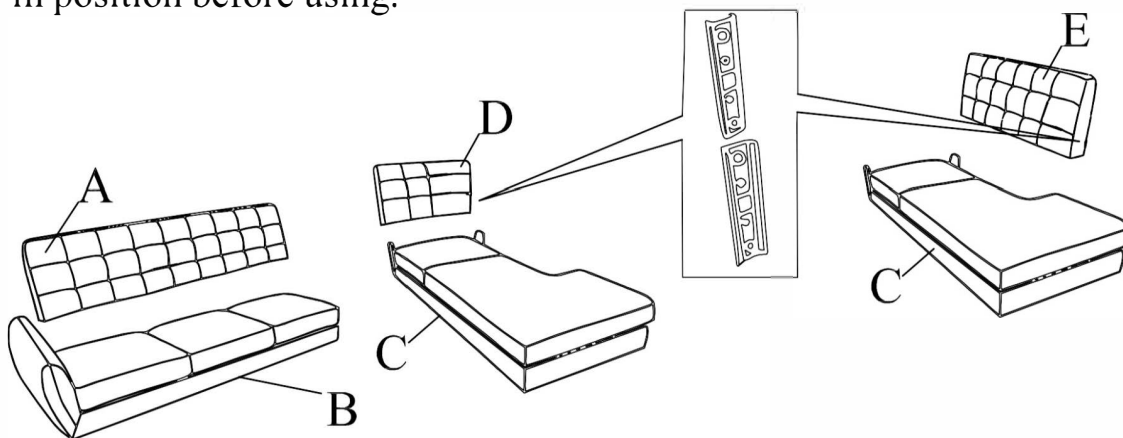

Step 3. Left - facing sofa and right - facing chaise can be attached together by the brackets as shown in below drawings.

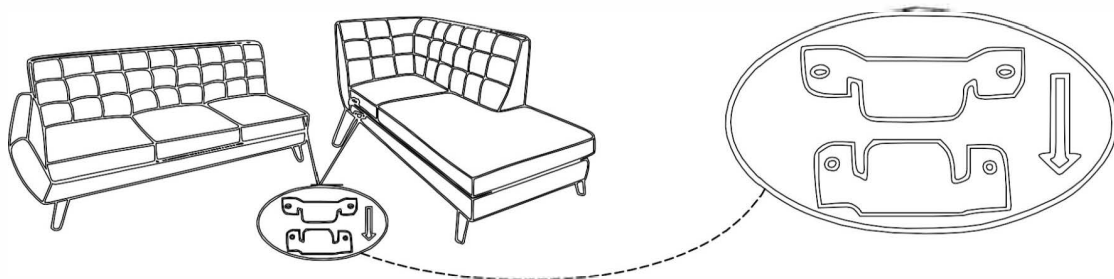

Step 4. Completed

