

Assembly Instructions

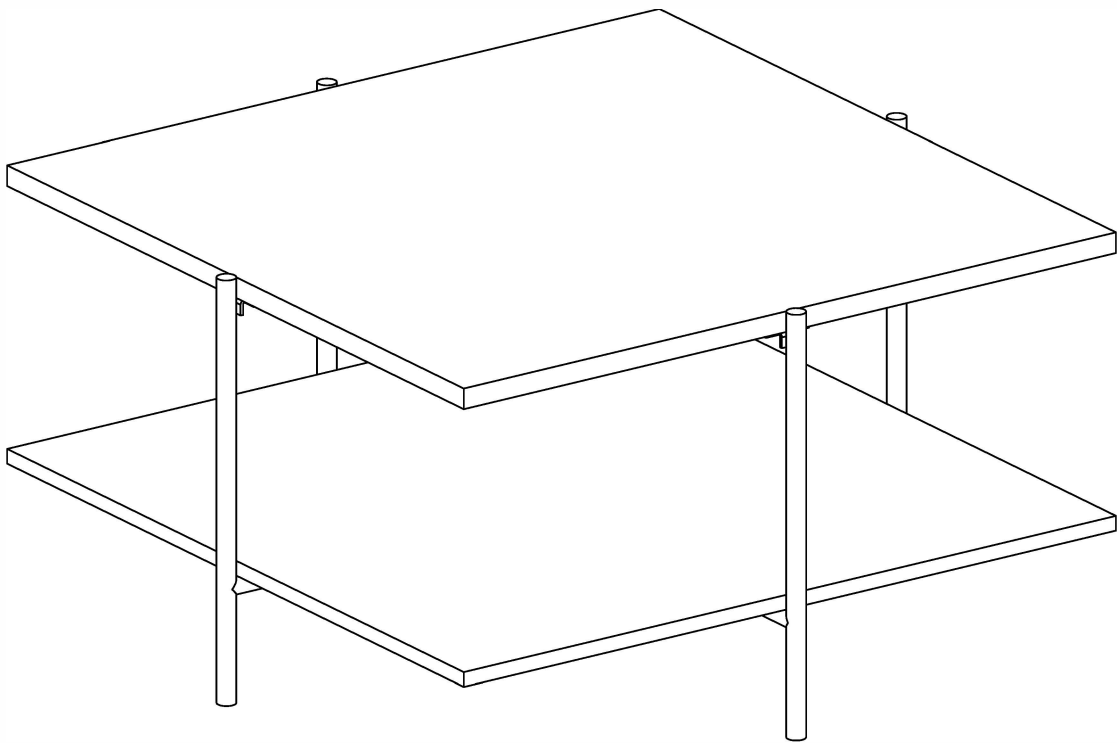

General Assembly Guidelines

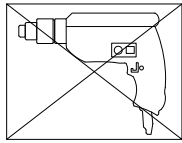

- I. Ensure that all parts and hardware are available before beginning assembly.
- II. Follow each step carefully to ensure the proper assembly of this product.
- III. Two people are recommended for ease in the assembly of this product.
- IV. The main type of hardware used to assemble this product is: bolts.
- V. Power tools should not be used to assemble this product .

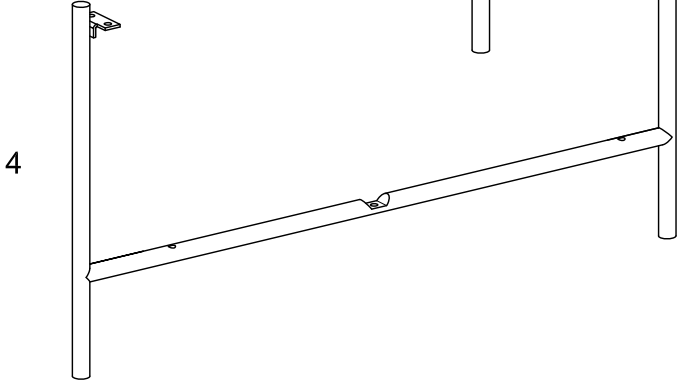
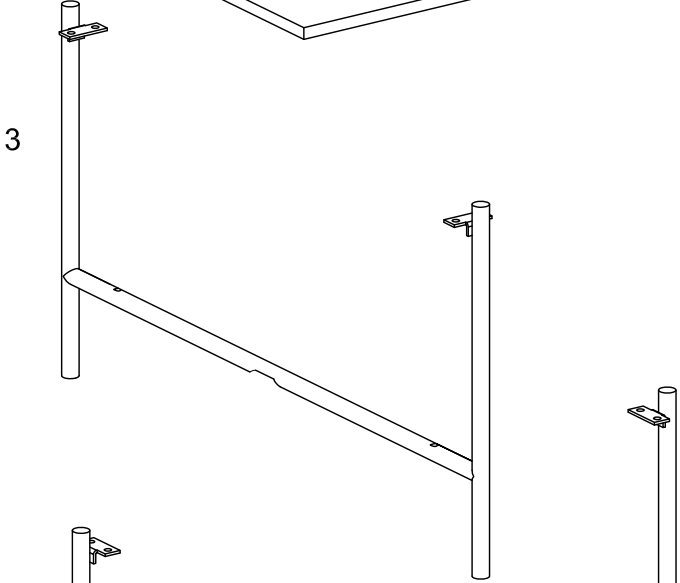
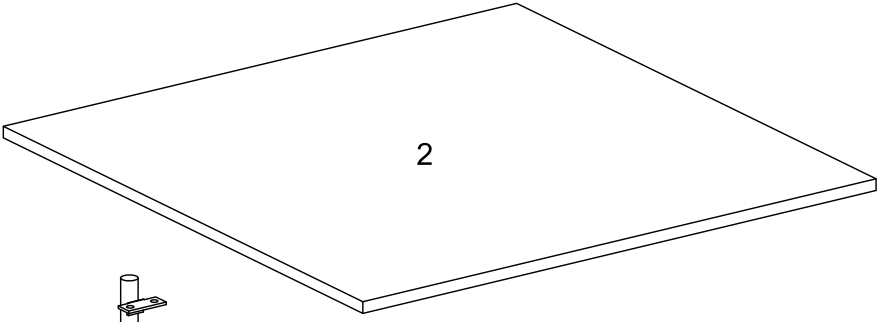
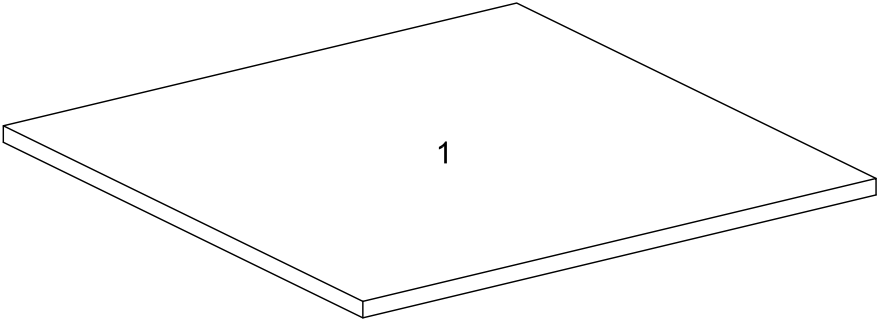

Parts List



Hardware List

A		Ø6x15mm	Bolt	8 pcs
B		Ø6x25mm	Bolt	4 pcs
C		M4	Hex Key	1 pc
A		Ø6x12mm	Bolt	1 pc

*The hardware quantities listed above are required for proper assembly.
Some extra hardware may also have been included.*

Step 1

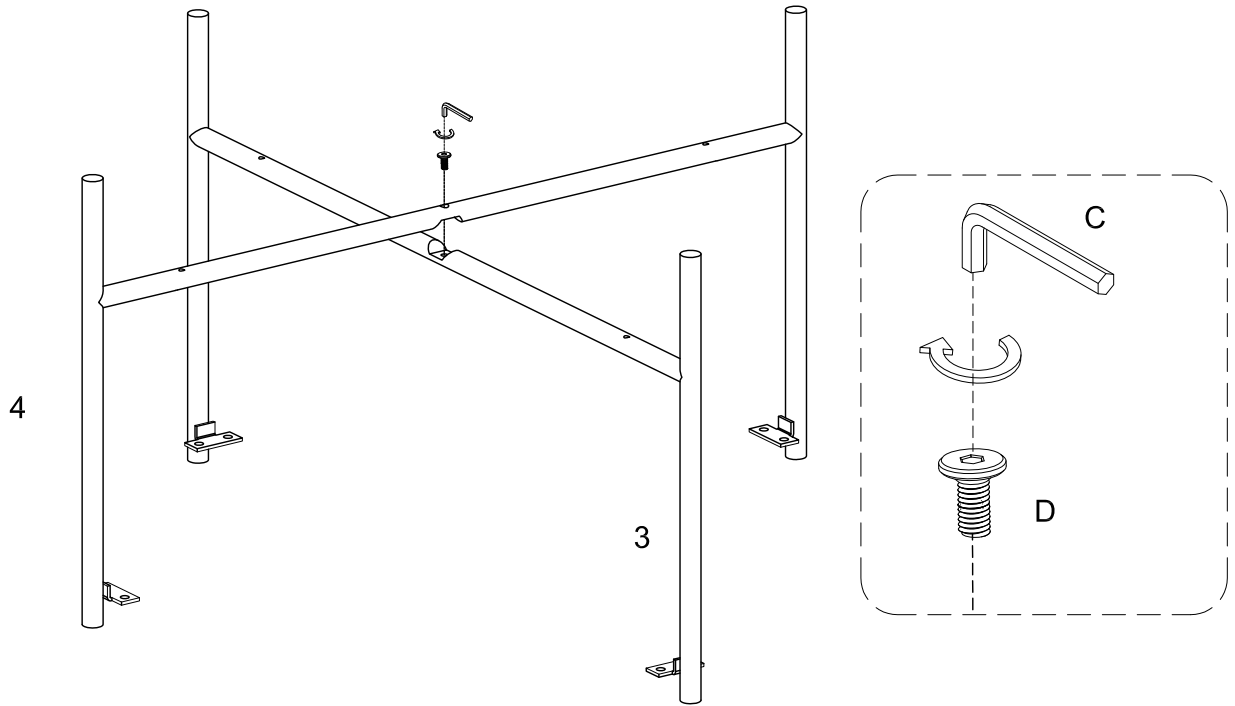

Attach part (4) to part (3) using bolt (D) with hex key (C).

Step 2

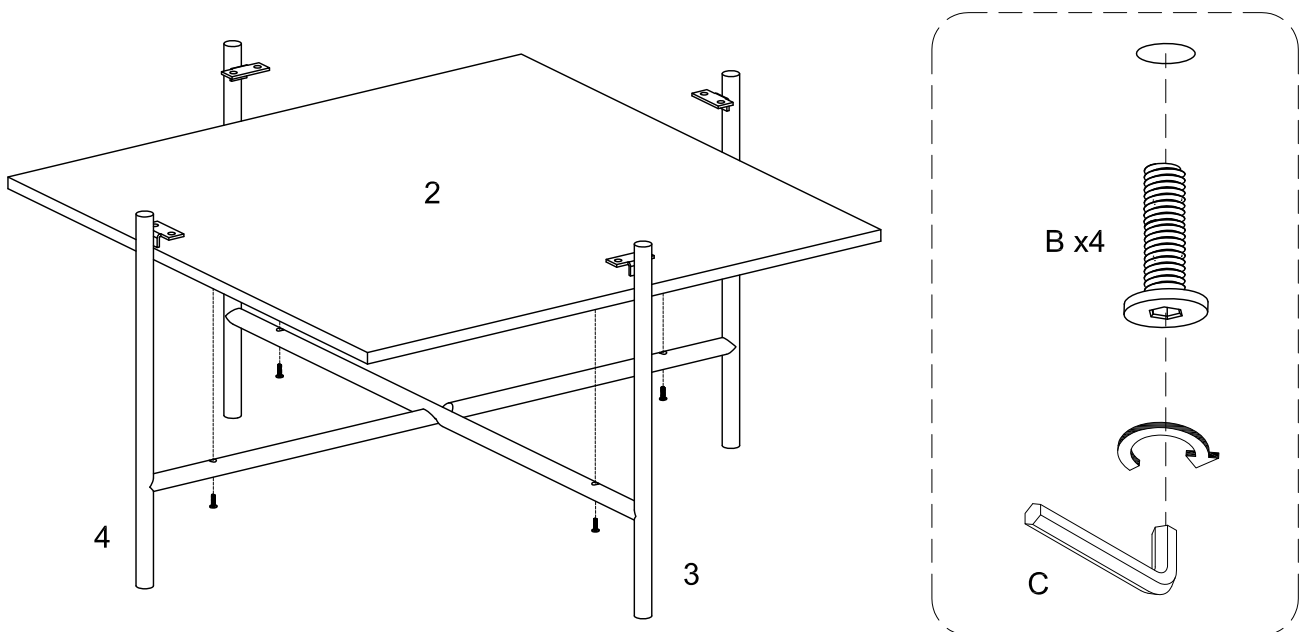

Attach part (3,4) to part (2) using bolt (B) with hex key (C).

Step 3

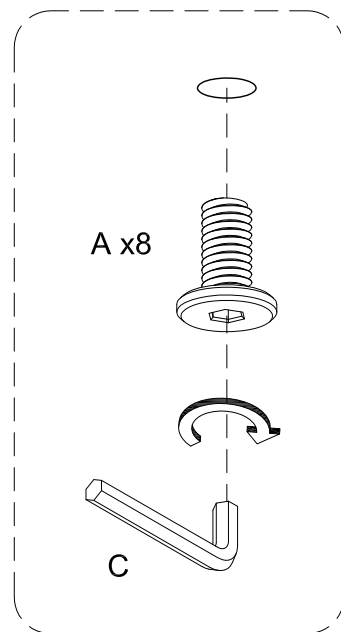
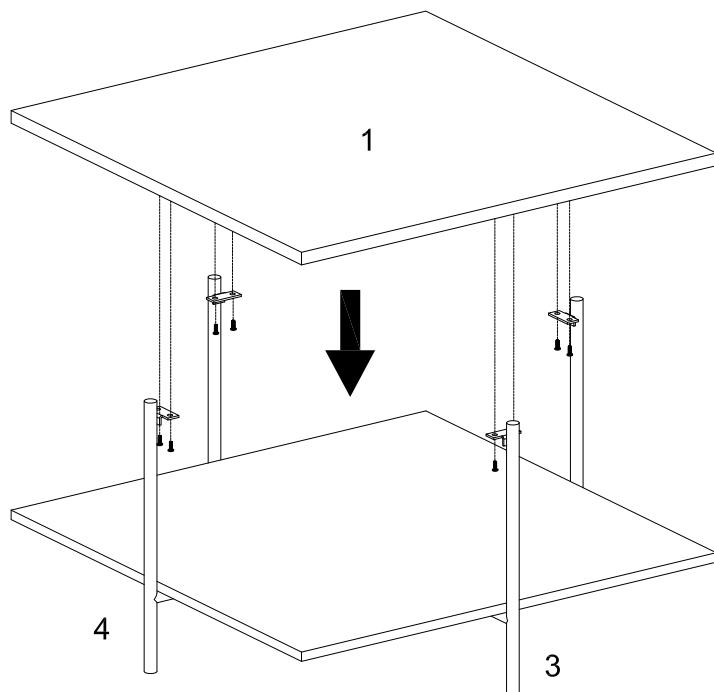

Attach part (3,4) to part (1) using bolt (A) with hex key (C).

Step 4

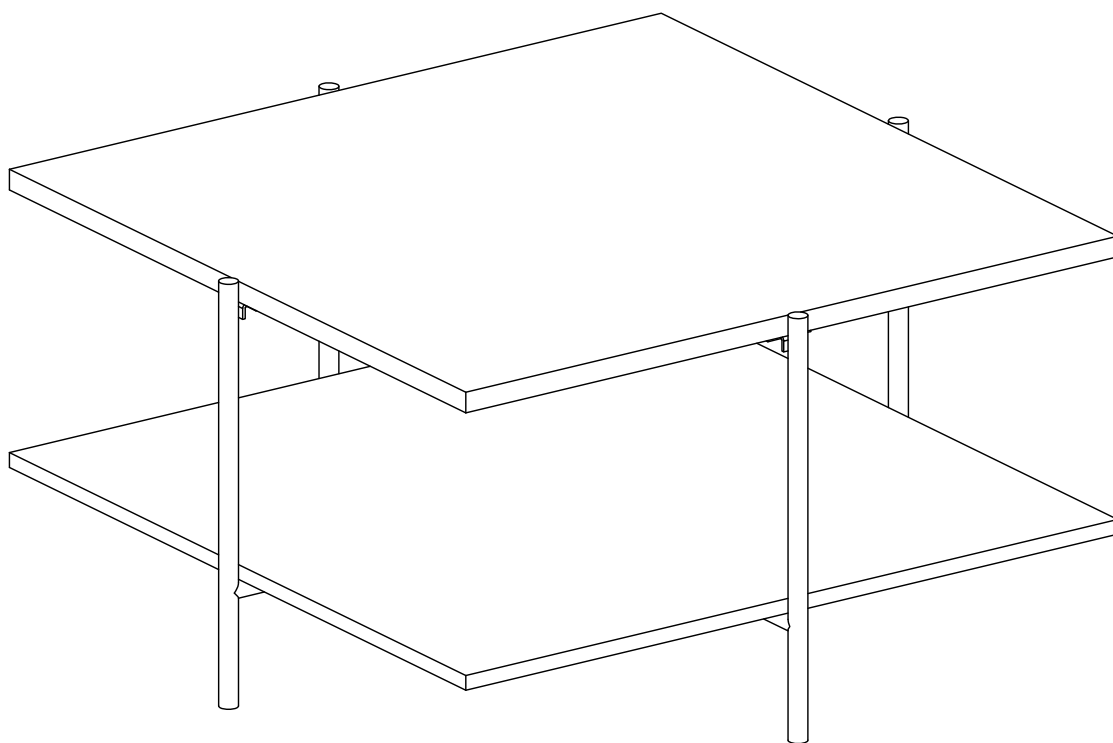

Final Assembly