

3'X5'FT METAL GARDEN SHED

INSTRUCTIONS FOR ASSEMBLY

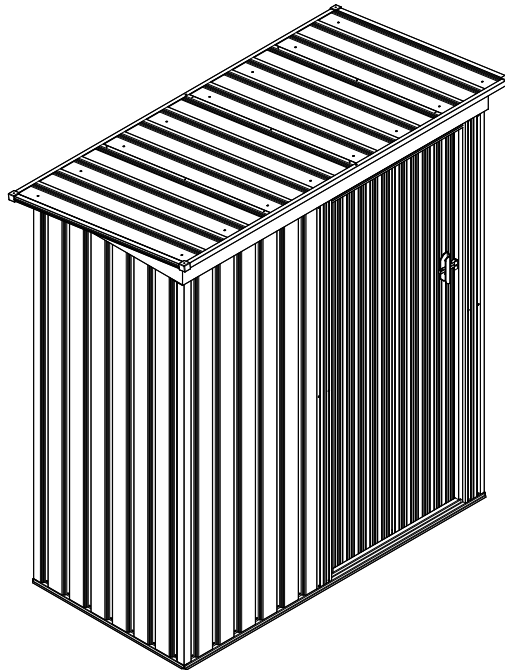

Requires two people and takes 2-3 hours for Installation.

Tall Walk in Shed
Quick & Easy Assembly
Ridge Reinforced Walls
Available in Various Sizes

PLAN AHEAD

Before beginning installation, check local building codes regarding footings, location and other requirements.

Study and understand this instruction.

Important information and helpful tips will make your installation easier and more enjoyable.















Tools and Materials: There are some basic tools and materials you will need for the installation. Decide which method of anchoring and the type of foundation you wish to use in order to form a complete list of the materials you will need.









BEFORE YOU BEGIN







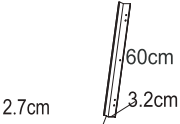
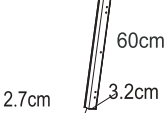
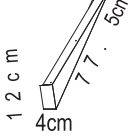
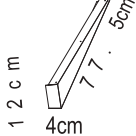

Assembly Instruction: Instructions are supplied in this manual and contain all appropriate information for your installation. Review all instructions before you begin, and during assembly, follow the step sequence carefully for correct results.

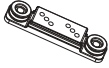
Parts List: Check to be sure that you have all the necessary parts and quantities in your package. These are packaged within the carton. Note that extra fasteners have been supplied for your convenience.

Explosion Diagram: All parts except screws and bolts are shown in this diagram, review all parts before you begin. Familiarize yourself with the hardware and fasteners for easier use during installation.

NO.	PART	Qty.
16	 162*2cm	1
17	 162*2cm	1
25R	 10*2.5*165cm	1
25L	 10*2.5*165cm	1
P1	 165*37cm	1
P1A	 165*37cm	1
P1D	 165*28cm	1
P2	 165*38.8*7cm	3
P3	 165*46cm	3
P4B	 165*24cm	1
P5	 87*46cm	3
P7	 87*37cm	1
D1R	 164*318cm	1
D1L	 164*318cm	1

NO.	PART	Qty.
1	 75*6cm	2
3	 150*13cm	1
4	 150*6cm	1
6	 77*3.5cm	1
7	 147*3cm	1
9	 72.5*2cm	2
10	 147*2cm	1
12L	 152*12*4.7cm	1
15	 87*2cm	2
20U	 2.7cm 60cm 3.2cm	1
20D	 2.7cm 60cm 3.2cm	1
21R	 12cm 4cm 7cm 5cm	1
21L	 12cm 4cm 7cm 5cm	1



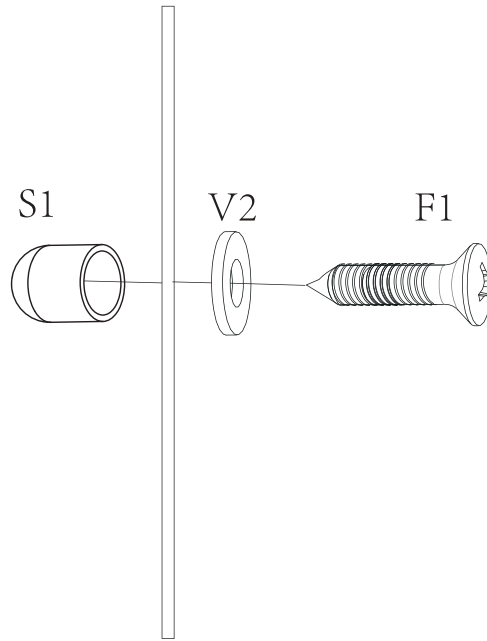

NO.	PART	Qty.
S1	 0.7*1cm	122
G2	 9*2cm	2
GB	 11.8*3.8cm	1
GC	 3*3cm	4
GD	 3.6*1.8cm	2
V2	 6*4.7cm	122
F1	 4*10	142
F2	 M4*10	22
F3	 5*16	4
F6		4

PART	NO.	Qty.
	S1	122

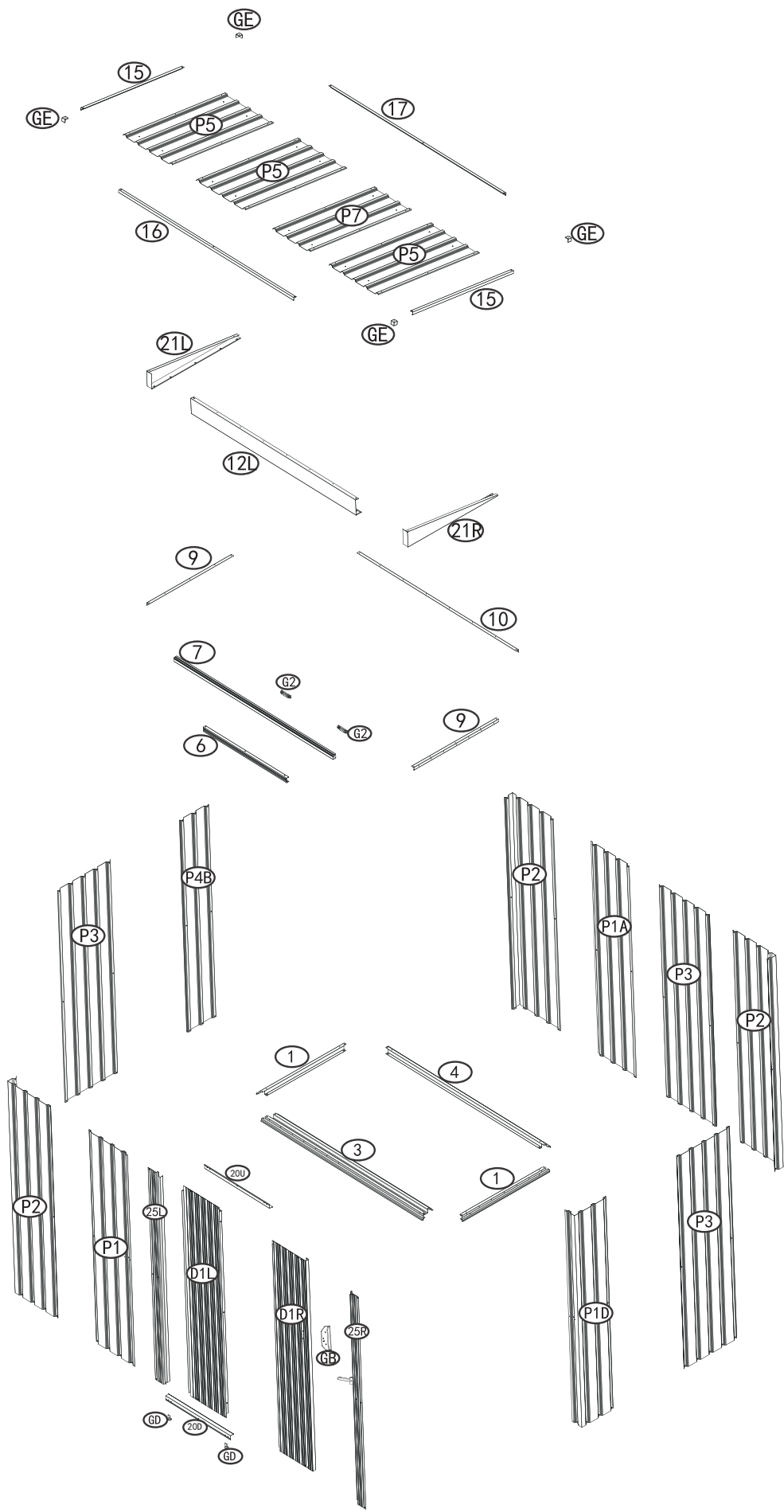



Reminder: Tighten each screw, and then put the screw cap to prevent scratches



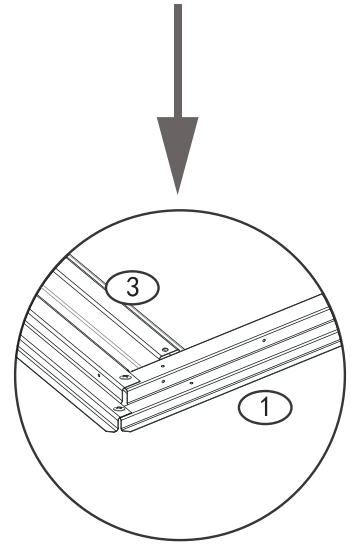
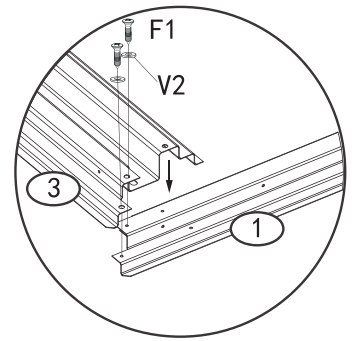
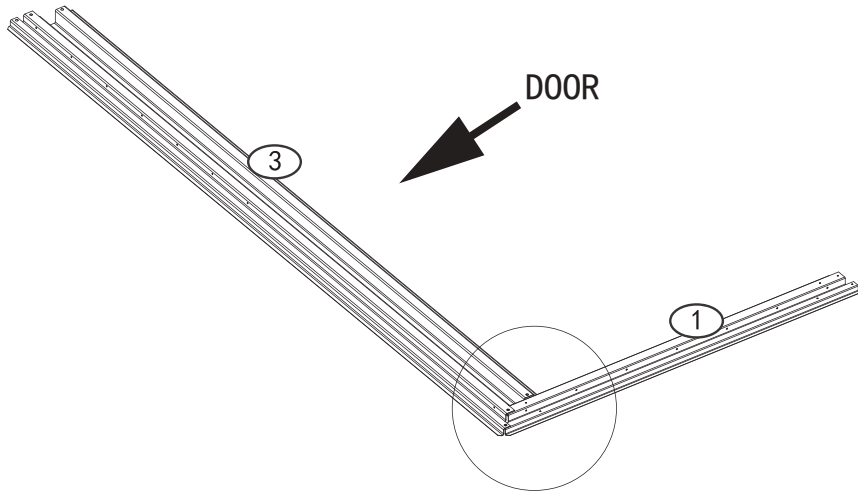

PART	NO.	Qty.
	3	1
	1	1
	F1	2
	V2	2



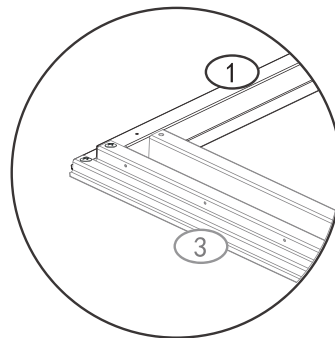
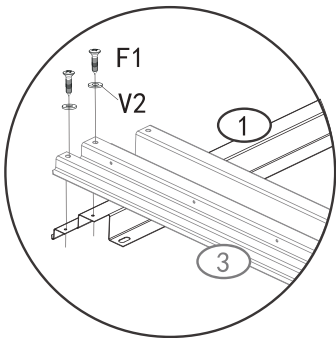
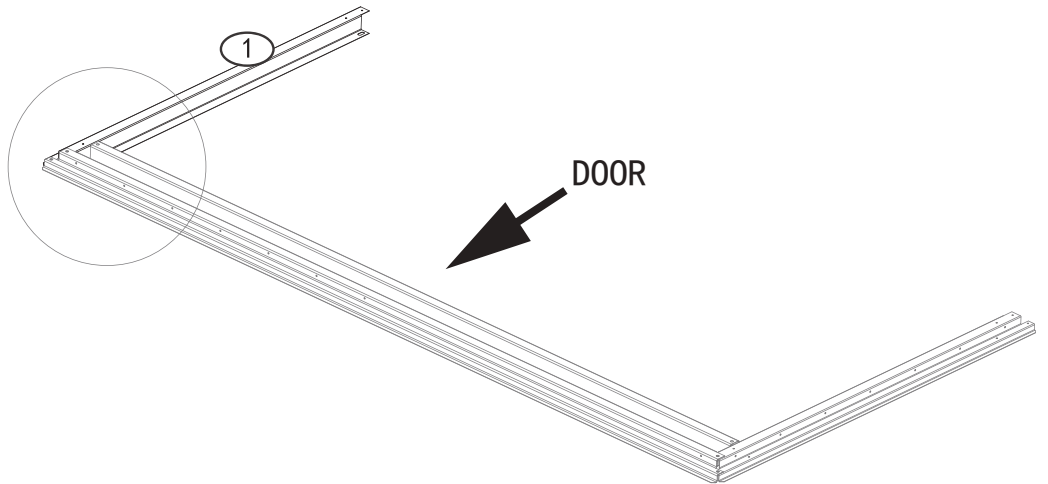

PART	NO.	Qty.
	1	1
	F1	2
	V2	2



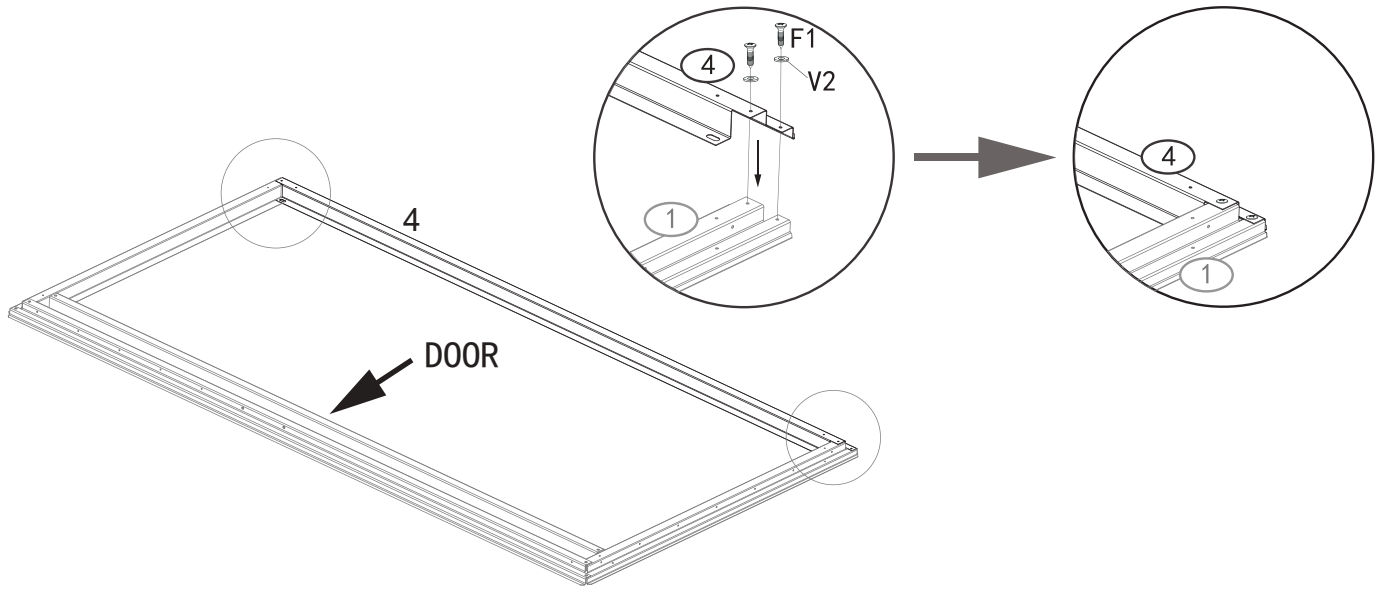
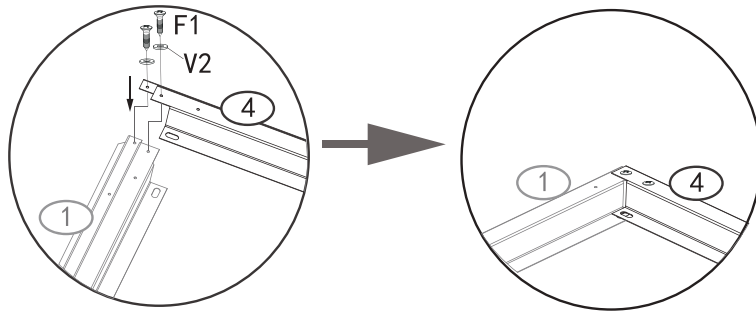

PART	NO.	Qty.
	4	1
	F1	4
	V2	4



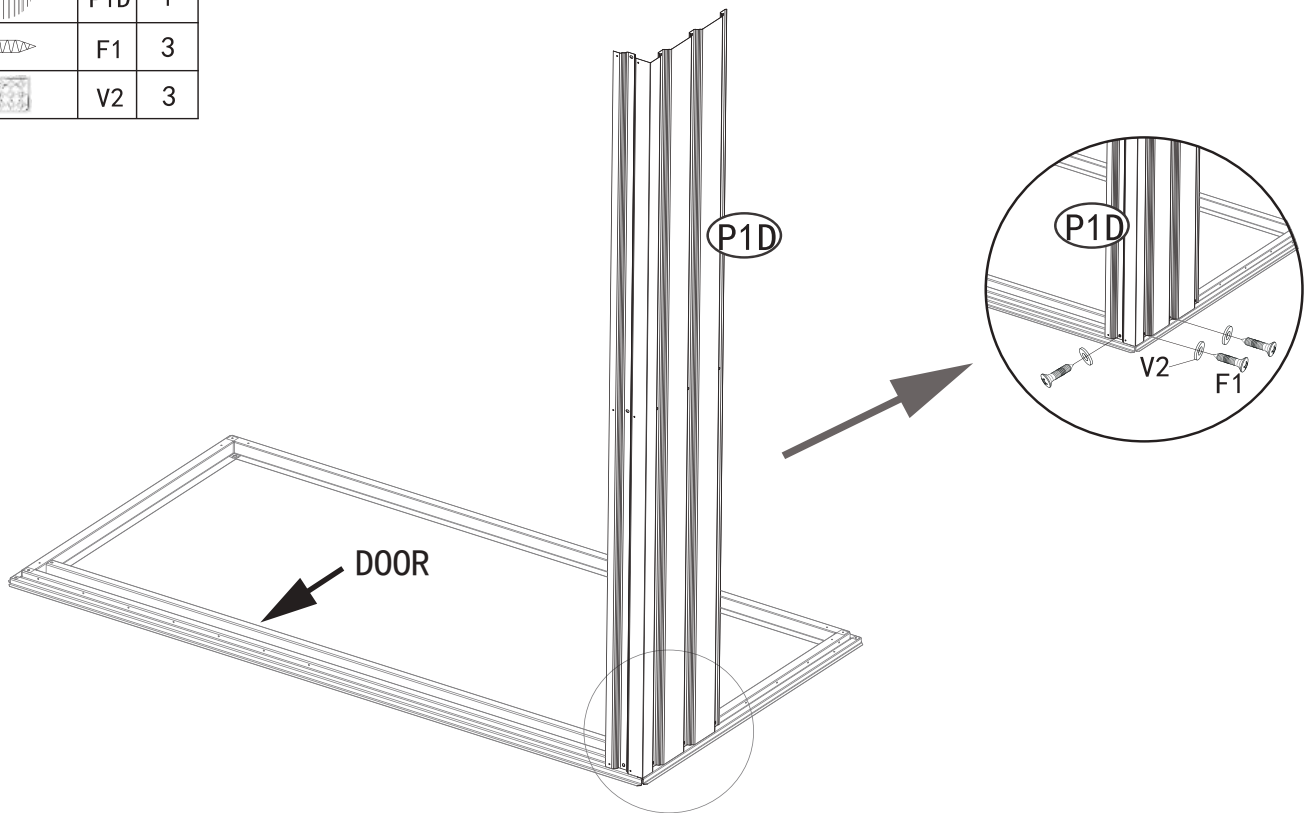

PART	NO.	Qty.
	P1D	1
	F1	3
	V2	3



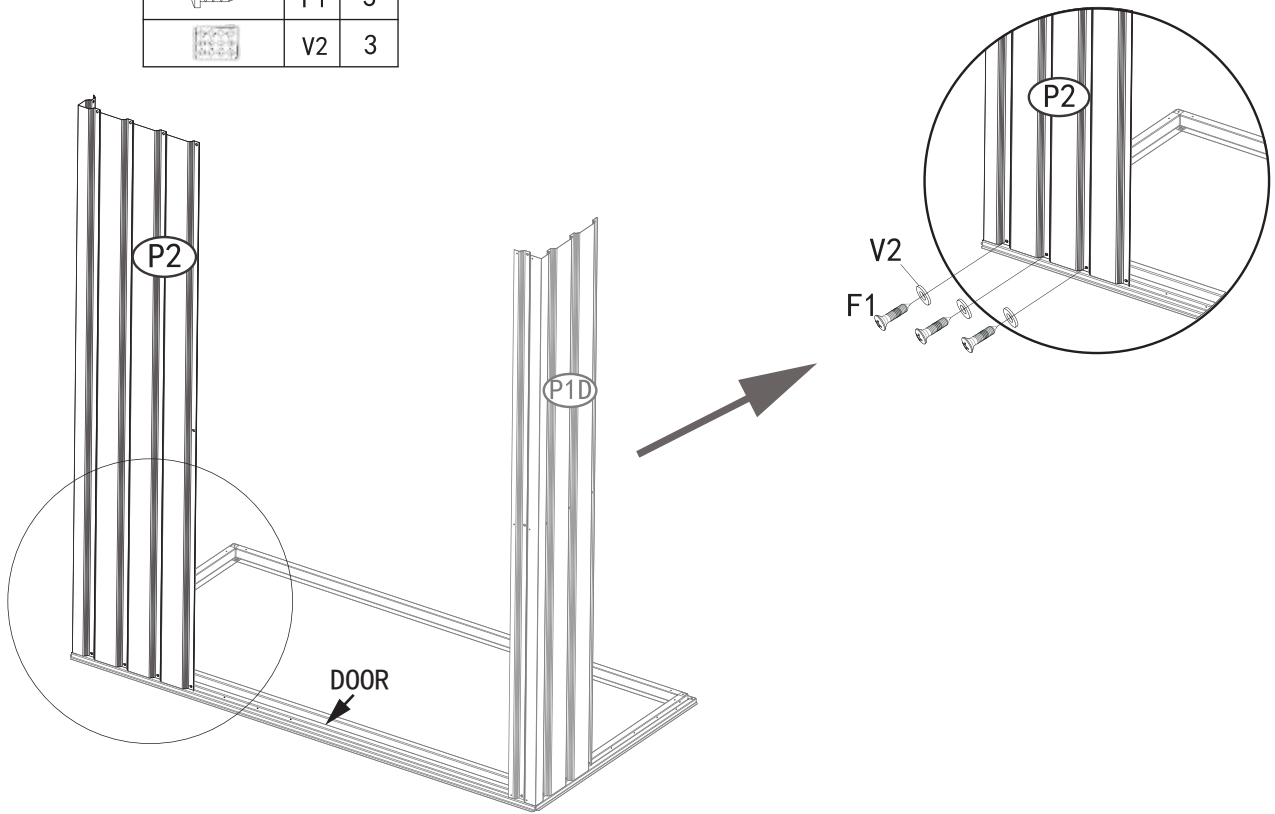



PART	NO.	Qty.
	P2	1
	F1	3
	V2	3

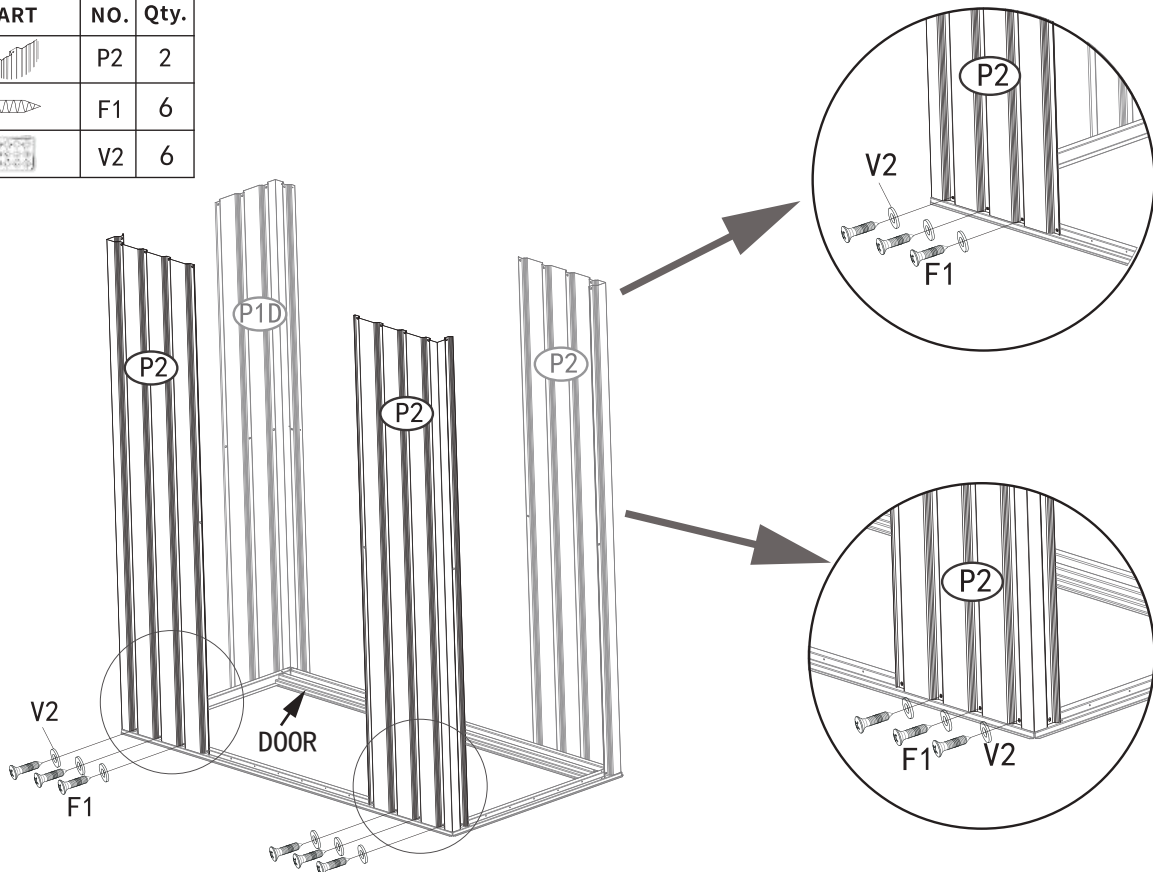



PART	NO.	Qty.
	P2	2
	F1	6
	V2	6



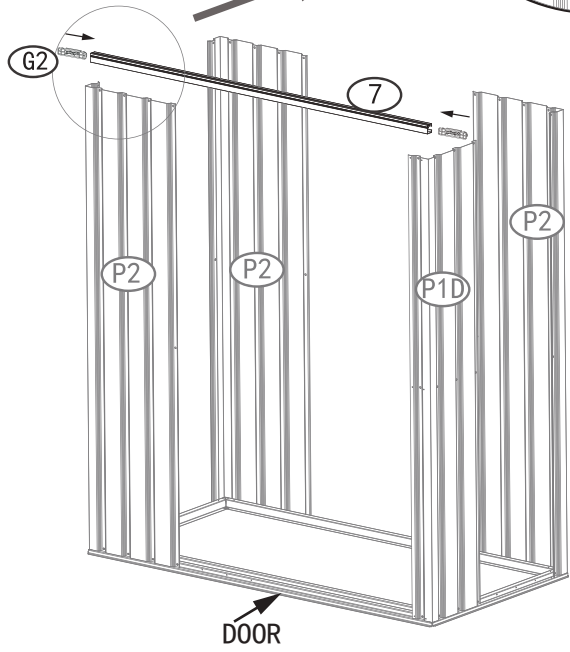

PART	NO.	Qty.
	7	1
	G2	2
	F1	3
	V2	3



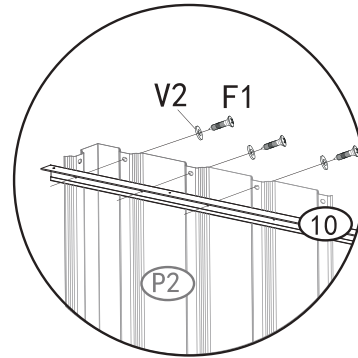
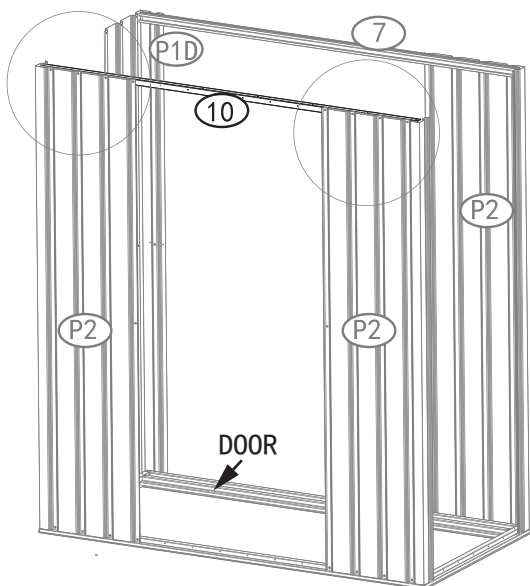



PART	NO.	Qty.
	10	1
	F1	6
	V2	6



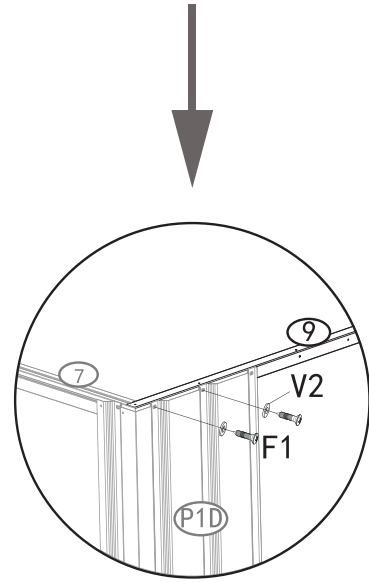
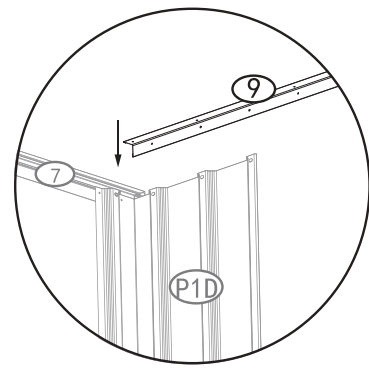
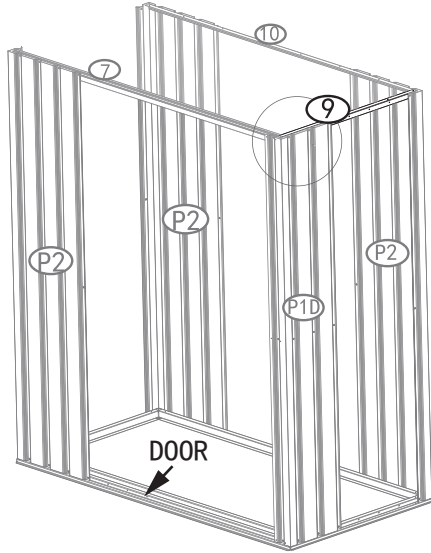



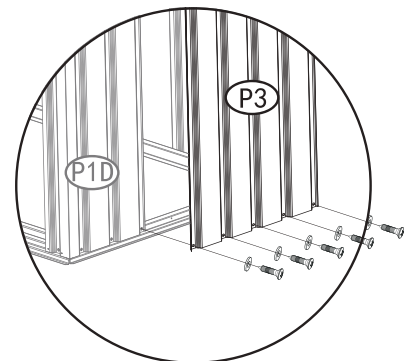
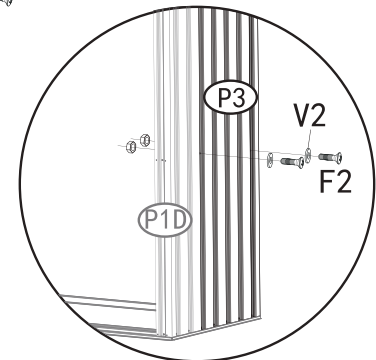
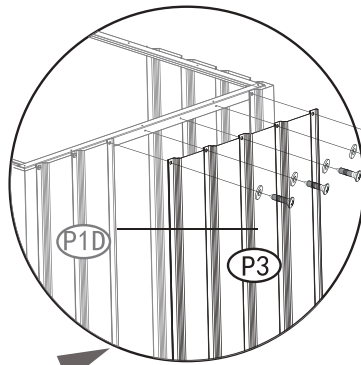
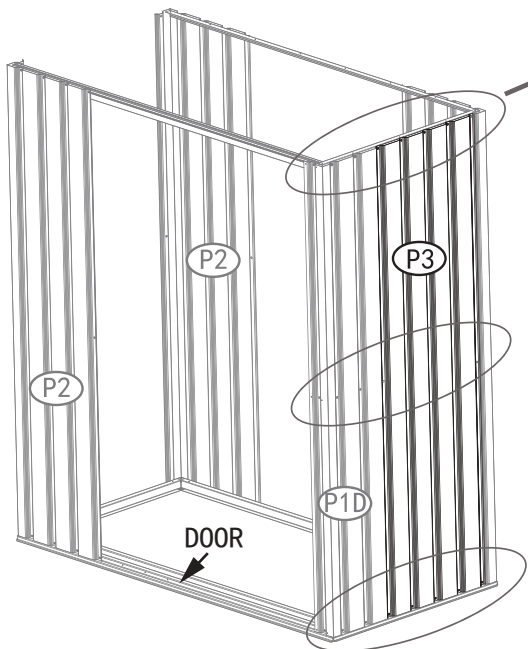

X2

PART	NO.	Qty.
	9	1
	F1	2
	V2	2







PART	NO.	Qty.
	P3	1
	F2	2
	F1	10
	V2	10

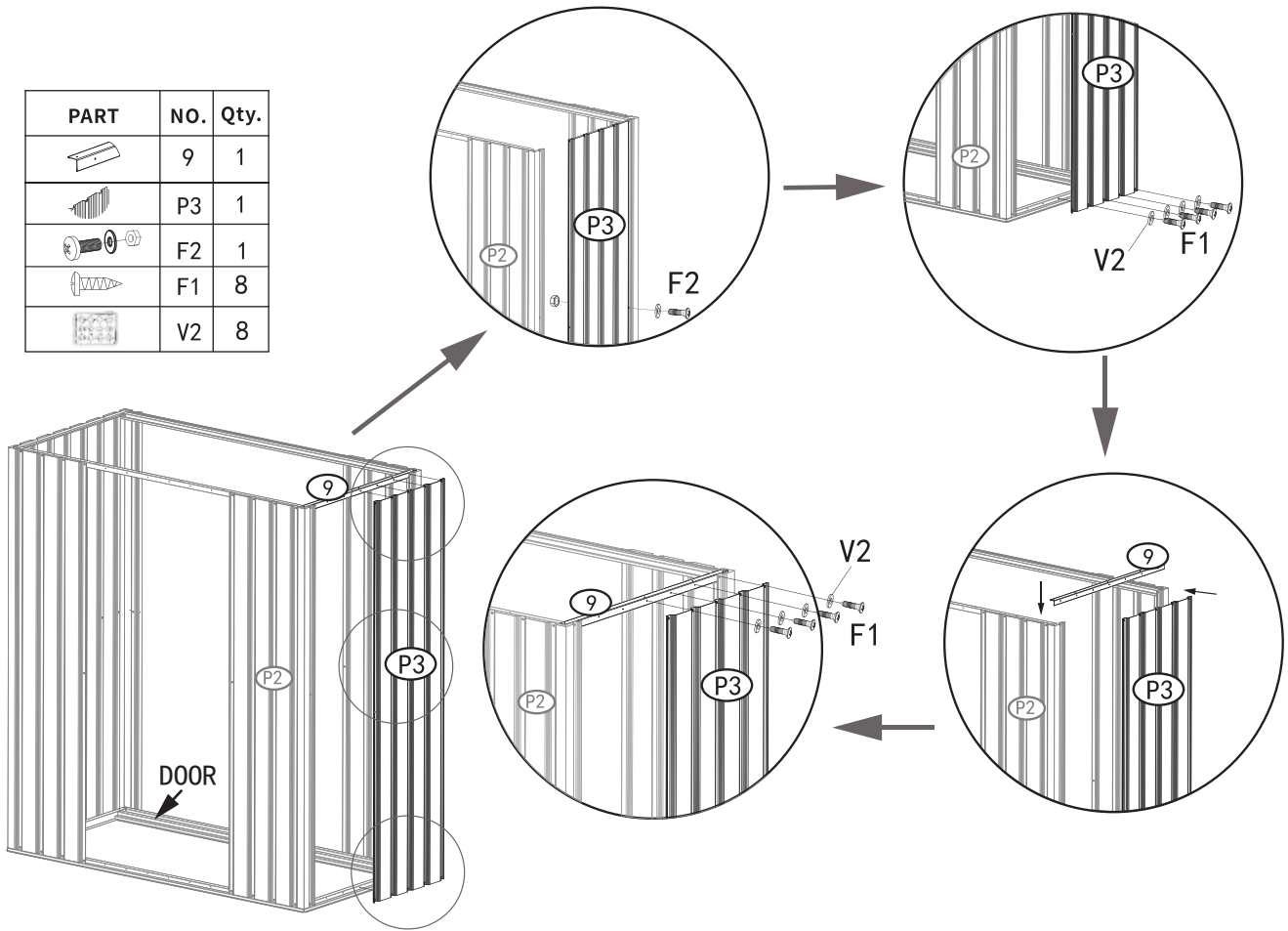

PART	NO.	Qty.
	9	1
	P3	1
	F2	1
	F1	8
	V2	8



PART	NO.	Qty.
	P4B	1
	F2	2
	F1	6
	V2	6

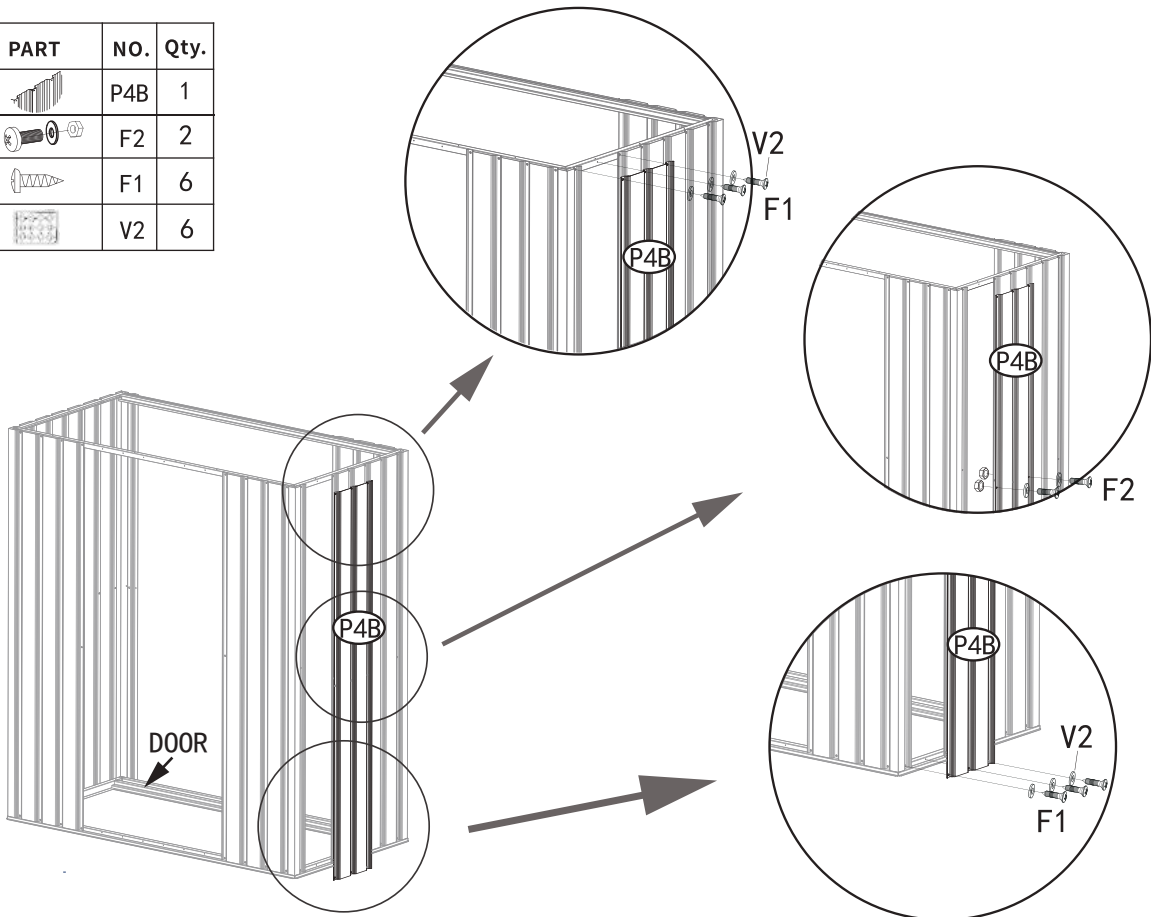

PART	NO.	Qty.
	P1A	1
	P3	1
	F2	3
	F1	16
	V2	16

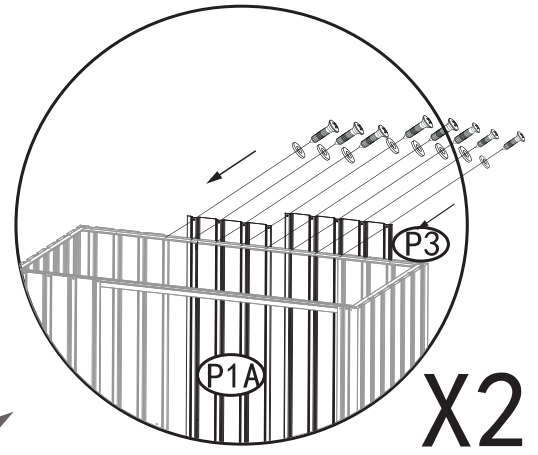



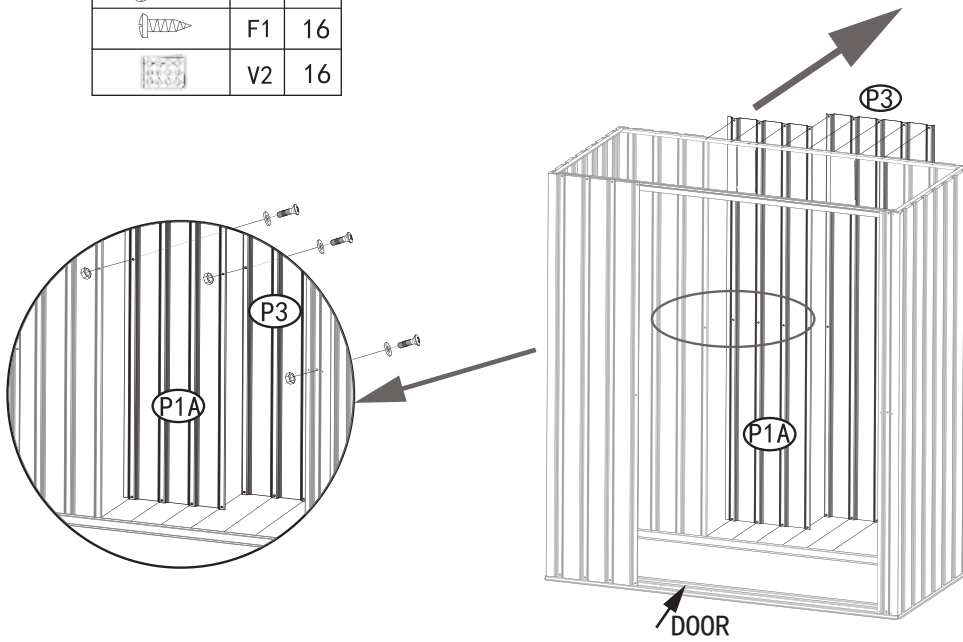

X2

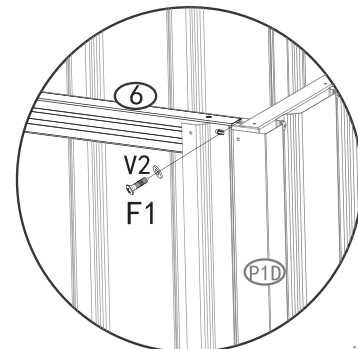
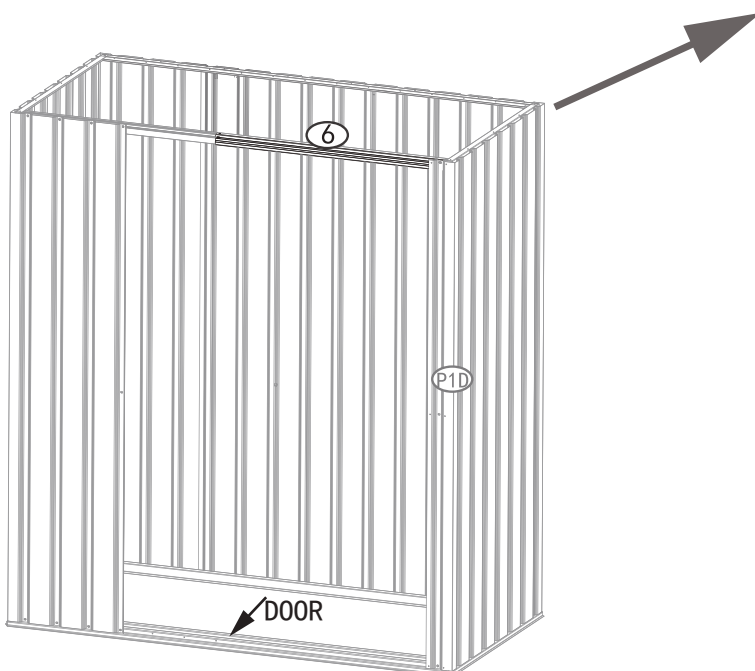





PART	NO.	Qty.
	6	1
	F1	1
	V2	1

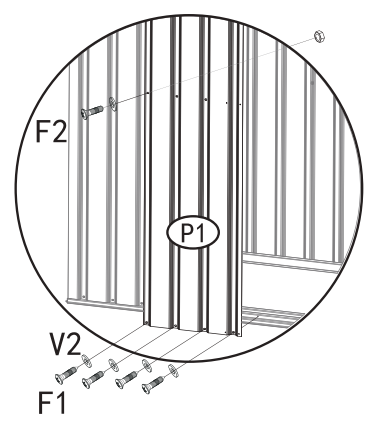
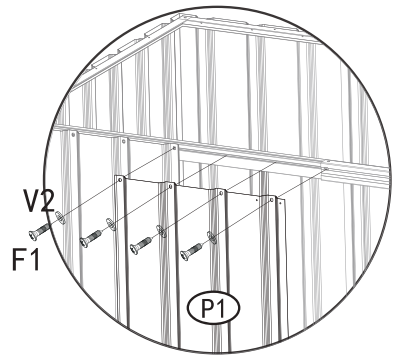
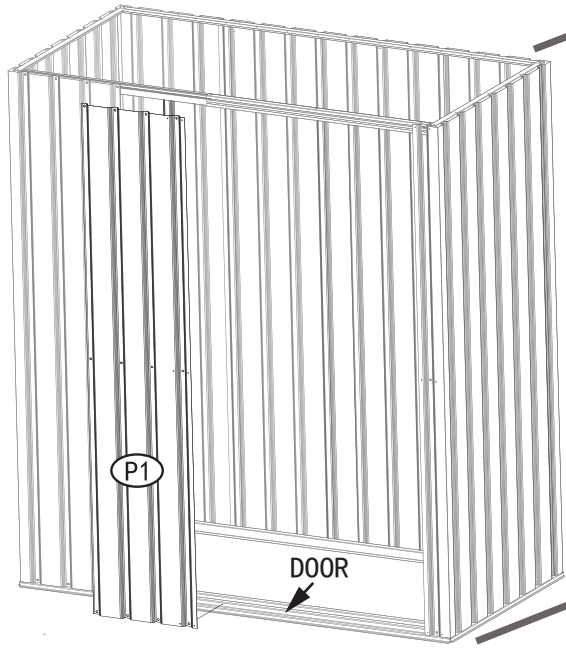



PART	NO.	Qty.
	P1	1
	F2	1
	F1	8
	V2	8



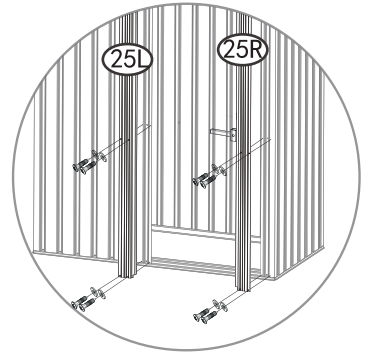
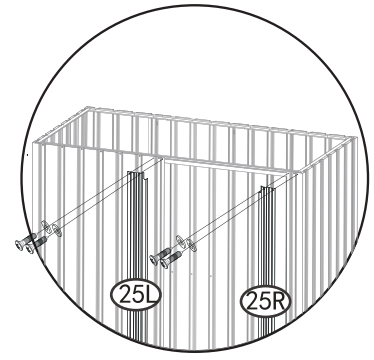
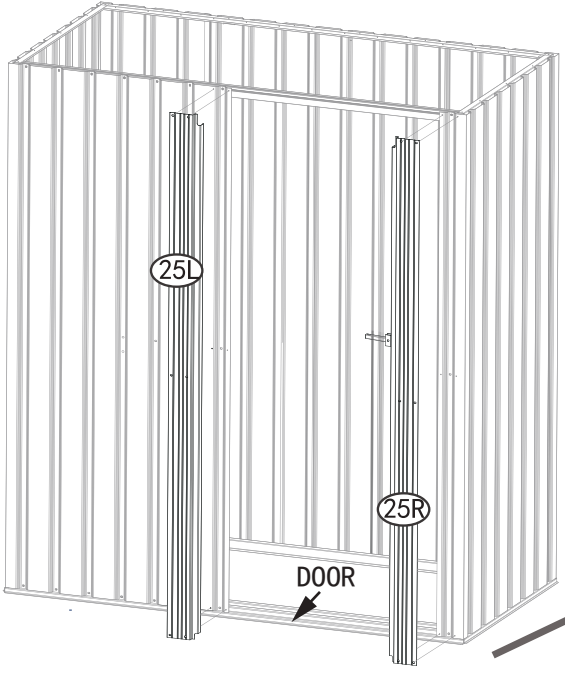



PART	NO.	Qty.
	25L	1
	25R	1
	F1	12
	V2	12

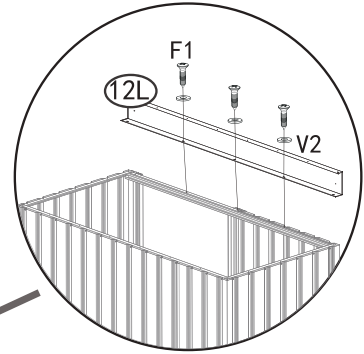
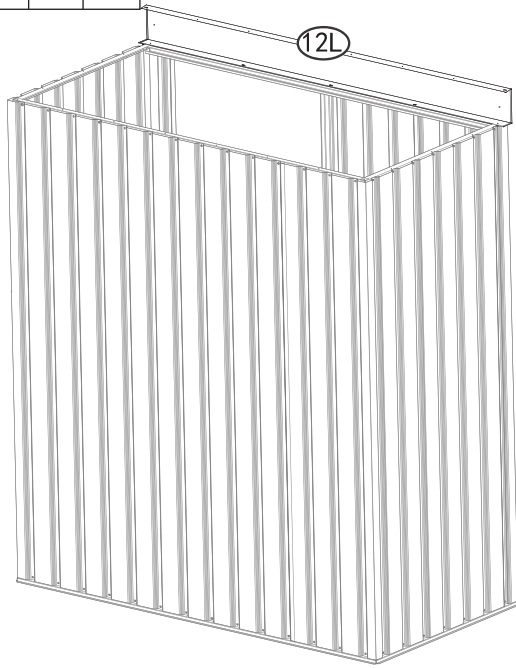

PART	NO.	Qty.
	12L	1
	F1	3
	V2	3





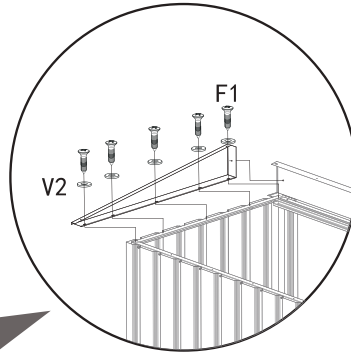

PART	NO.	Qty.
	21L	1
	25R	1
	F1	10
	V2	10
	F2	2

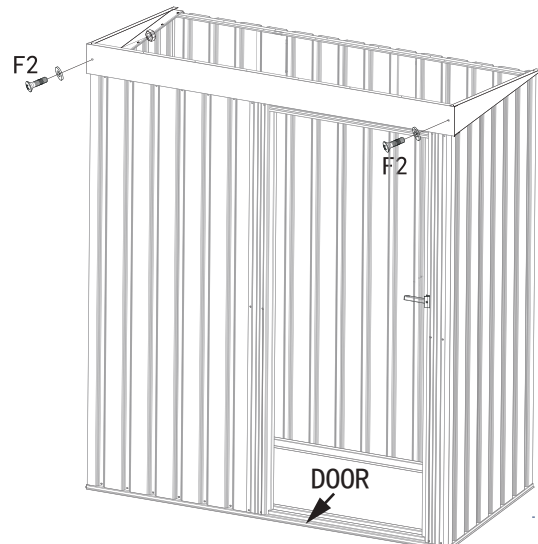
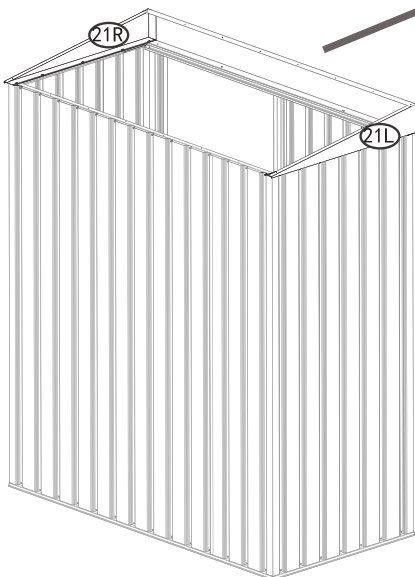





X2

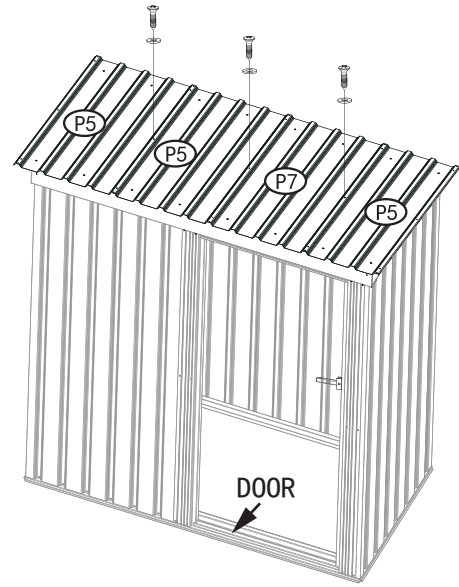
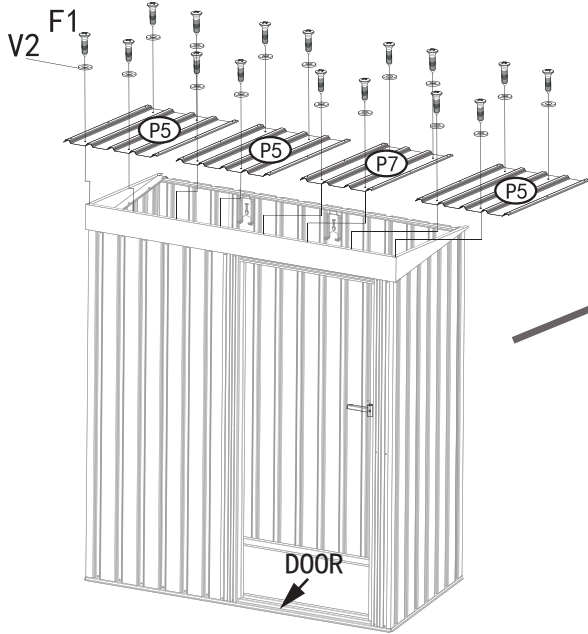





PART	NO.	Qty.
	P5	3
	P7	1
	F1	19
	V2	19

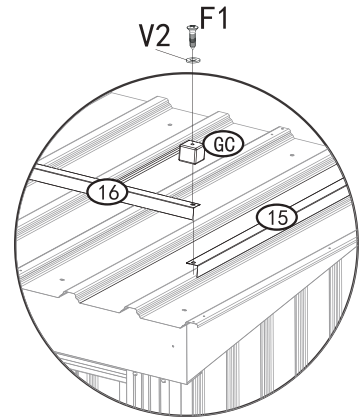
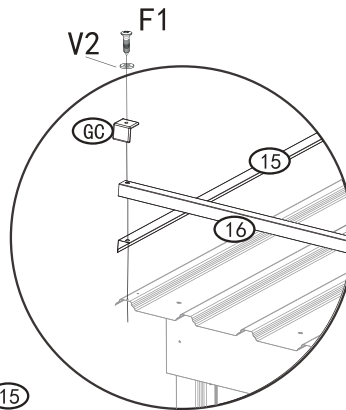
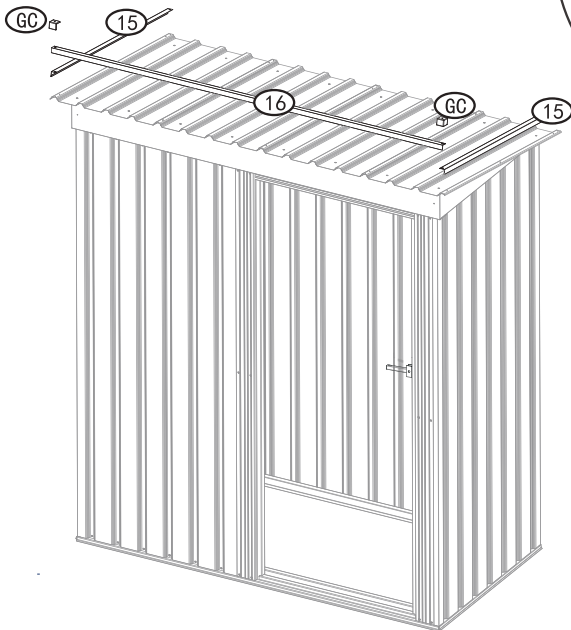





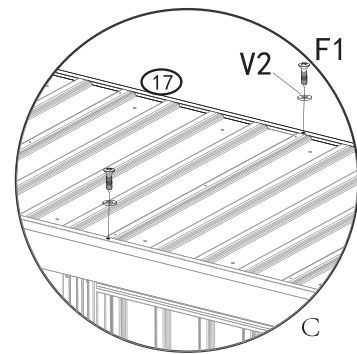
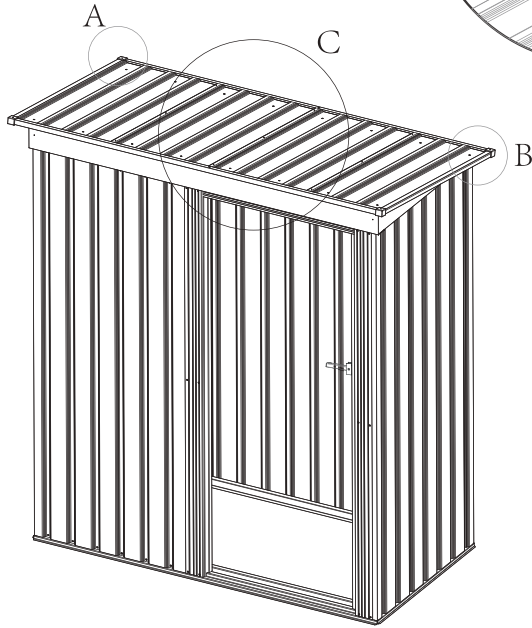
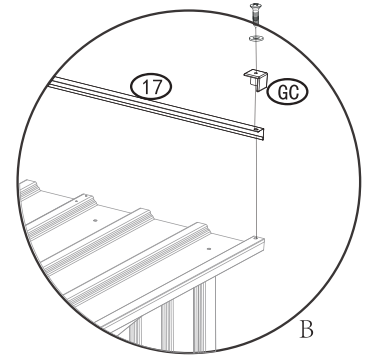
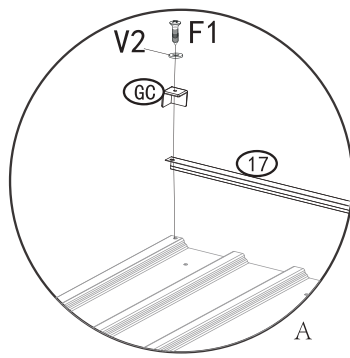

PART	NO.	Qty.
	16	1
	15	2
	GC	2
	F1	2
	V2	2





PART	NO.	Qty.
	17	1
	GC	2
	F1	4
	V2	4



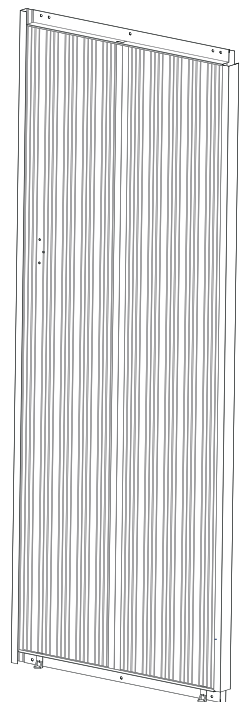
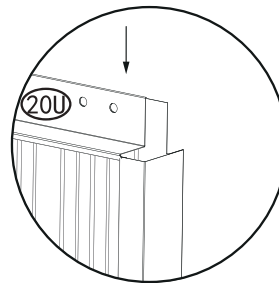
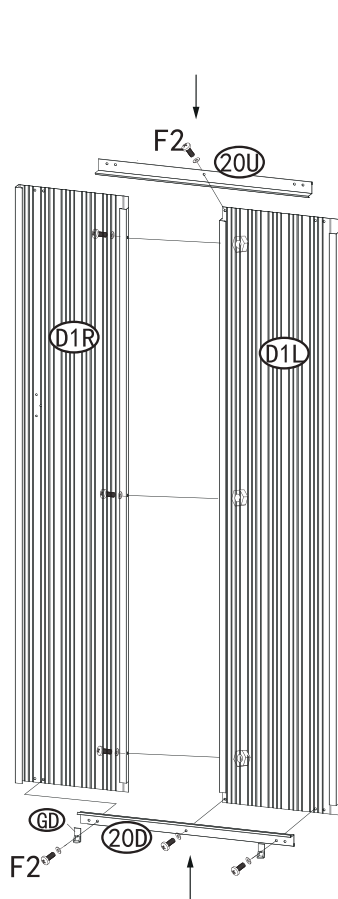

PART	NO.	Qty.
	20U	1
	20D	1
	D1R	1
	D1L	1
	F2	7
	GD	2

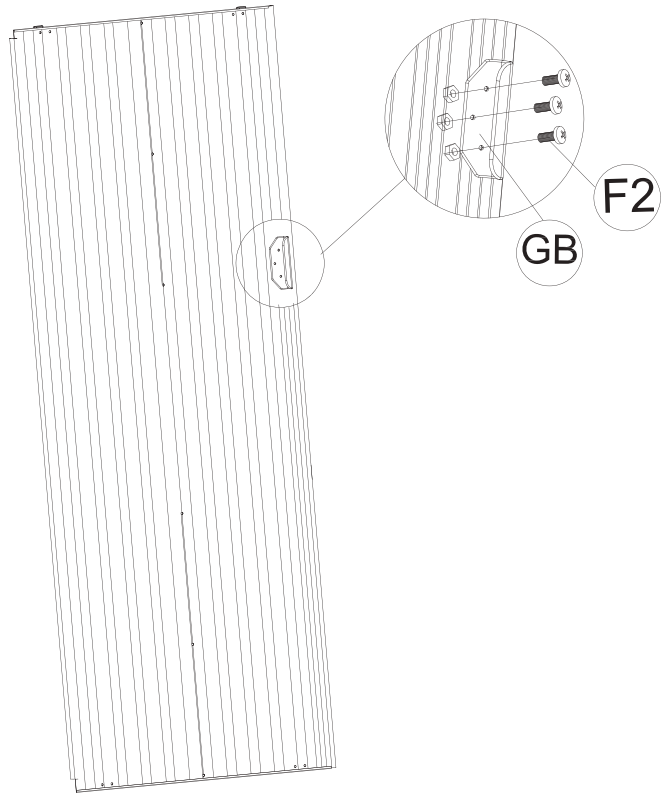

PART	NO.	Qty.
	GB	1
	F2	3



PART	NO.	Qty.
	GB	1
	F3	4

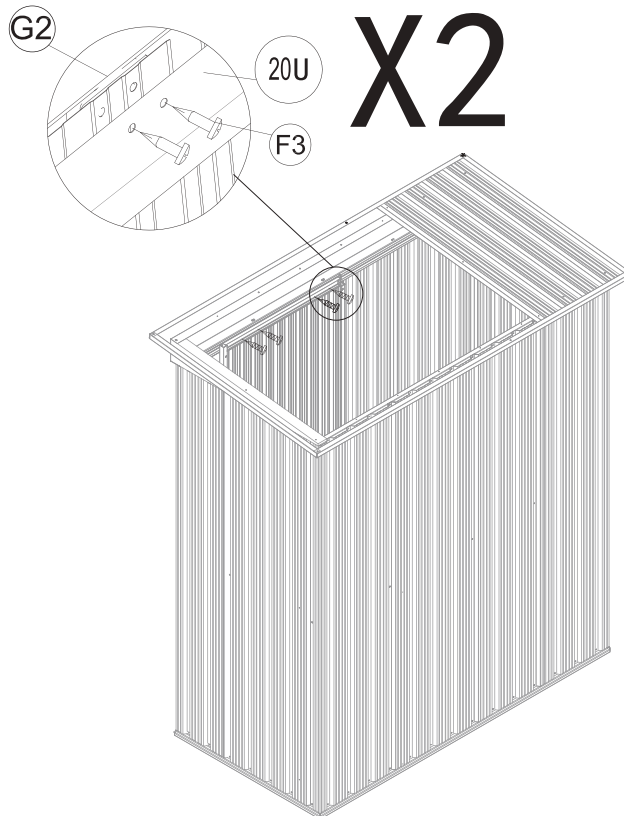

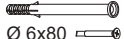
	No#:	Quantity
	F6	4

