

STOP VALVE AND SUPPLY TUBE INSTALLATION

1. Apply Teflon tape to thread of the pipe (2) and screw it with the stop valve (3).
2. Slide the escutcheon (1) onto the pipe and apply the Teflon tape to thread.
3. Screw stop valve to main water supply on wall. Use wrench to turn the valve and let the outlet go up. (Don't over turn the stop valve, it may damage the valve or pipe.)
4. Close the stop valve and briefly turn on the main water supply to check for leaks.
5. Loosen the nut (5) and compression ring (4) from stop valve, take the supply tube (6) and measure the length from stop valve to faucet valve, if necessary to cut the extra length of tube.
6. Slide the nut (7) onto the supply tube and set the cone washer (8) at top.
7. Slide the nut (5) and compression ring (4) from bottom of supply tube.
8. Attach the supply tube with faucet valve and stop valve. Tighten both nuts with wrench. (This copper supply tube can be bent slightly for installation)
9. Close the faucet valve and turn on the stop valve to check for leaks.

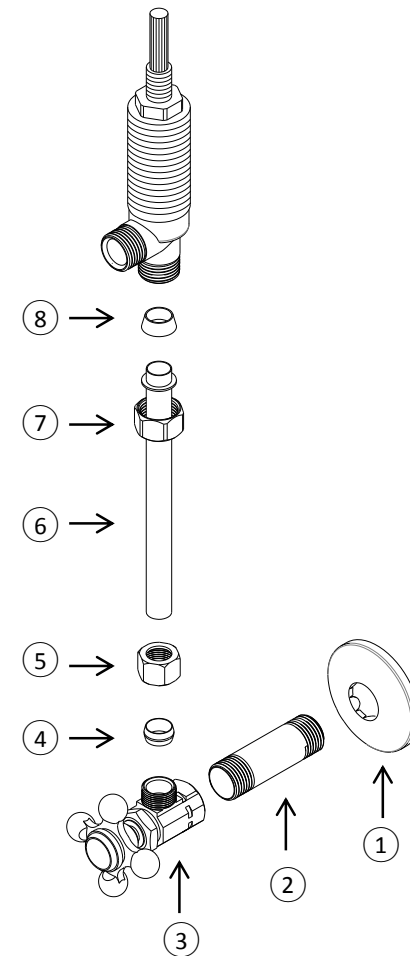

P TRAP INSTALLATION GUIDE

1. Remove horizontal pipe (2) and slip joint nut (3) from bottle trap (5).
2. Apply Teflon tape to all exposed threads.
3. Slide the slip joint nut (3) and escutcheon (1) onto horizontal pipe. Then insert the pipe into wall waste opening.
4. Remove slip joint nut (7) and washer (6) from bottle trap, to install it onto drain tail piece.
5. Attach bottle trap to drain tail piece and hand tighten slip joint nut.
6. Align bottle trap with horizontal pipe and drain tail piece, at this point it may be necessary to cut part of tail piece or part of horizontal pipe to obtain proper alignment.
7. After all components have been properly aligned, connect the bottle trap and horizontal pipe with slip joint nut, making sure to set the washer (4) before tighten the nut.
8. Check for leaks by opening faucet and letting water run for at least one minute.

