

Assembly Instructions

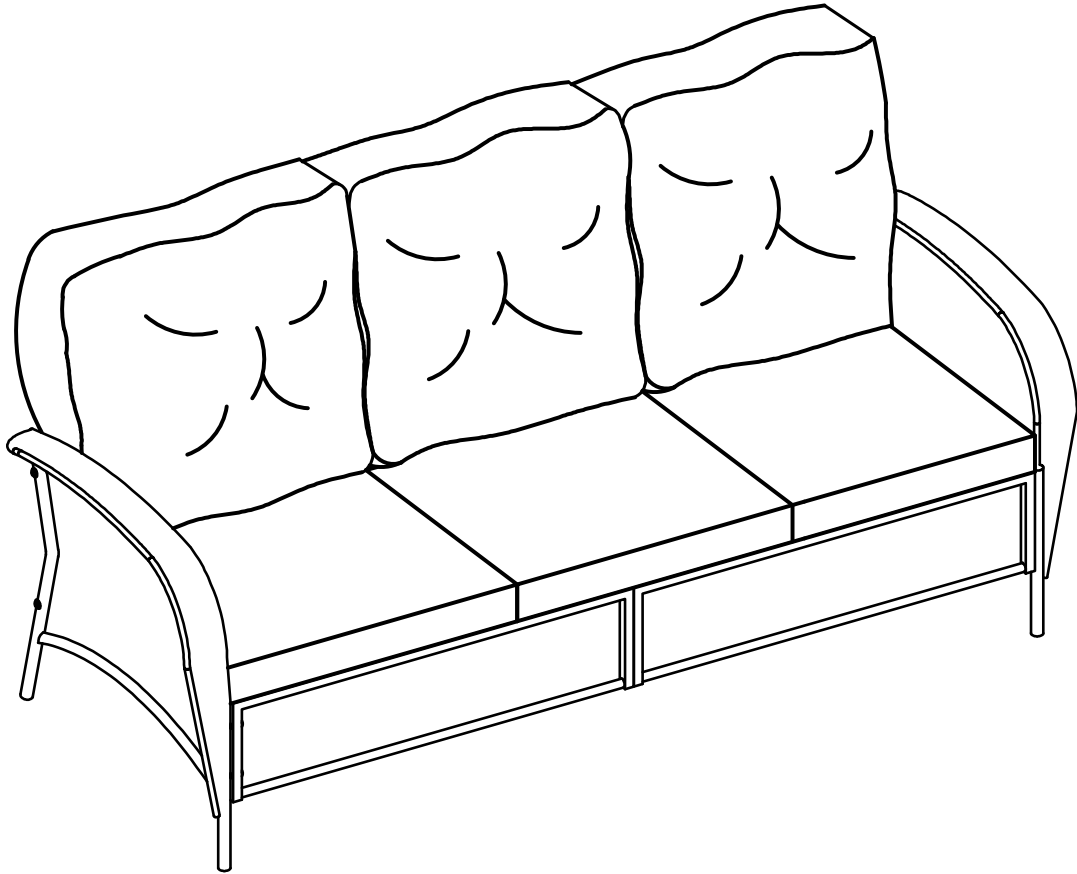











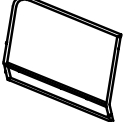

***Don't fully tighten all the bolts till the very end!**

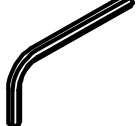
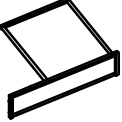
PRE ASSEMBLY PREPARATION:

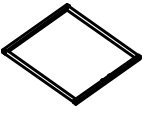
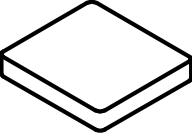
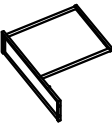
Please read through the instructions before beginning assembly. Clear out the space for assembly and lay out all of the parts based on the Parts List, extra room will allow you to easily determine if all the pieces are present.

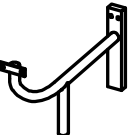
Keep small parts and pieces away from children until fully assembled.

Part no.	Part	QTY	Image	Part no.	Part	QTY	Image
A1	Left arm	1		I	Bolt (M6*38mm)	20	
A2	Right arm	1		J	Bolt (M6*45mm)	2	
B	Right Back Panel	1		K	Washer	24	
C	Left Back Panel	1		L	Allen Wrench	1	
D	Right Front Panel	1		M	Washer	1	
E	Middle seat	1		N	Seat Cushion	3	
F	Left Front Panel	1		O	Back Cushion	3	
G	Middle Foot	1					
H	Bolt (M6*15mm)	2					

Step 1: Attach back panels B&C with 2pcs bolts J and 2pcs washers K, using Allen wrench L. Note: Don't fully tighten the bolts.

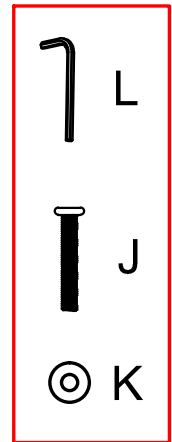
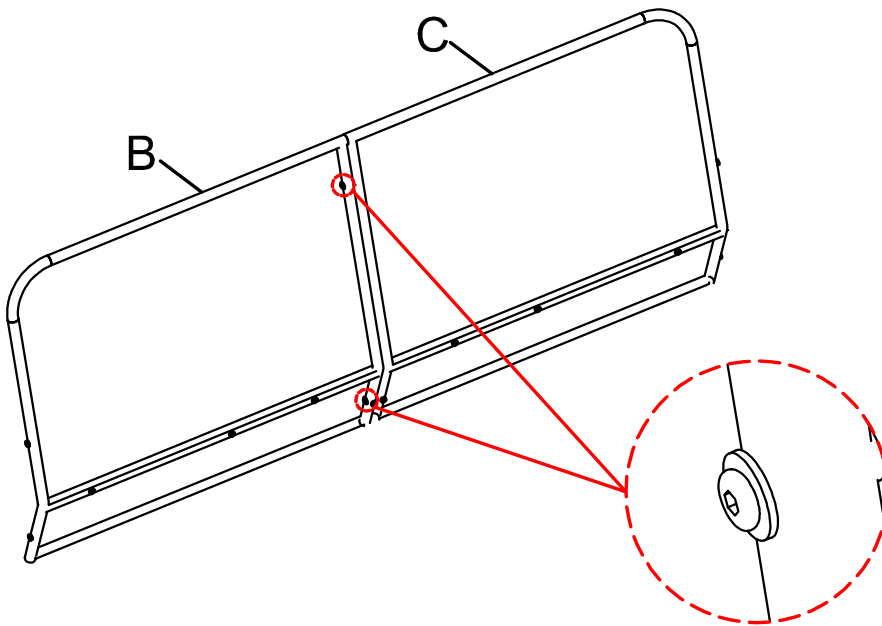

Step 2: Attach front panels F&D with 2pcs bolts I and 2pcs washers K, using Allen wrench L. Note: Don't fully tighten the bolts.

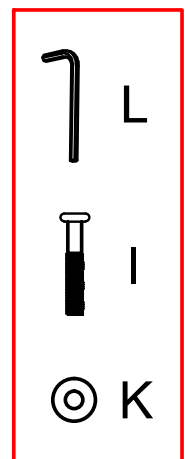
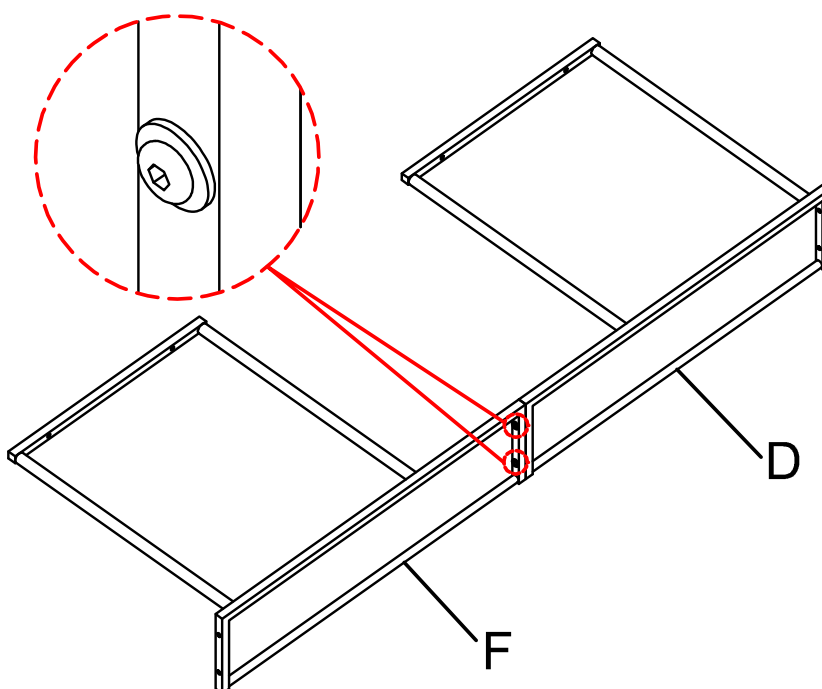

Step 3: Attach left arm A1 to back panel C with 2pcs bolts I and 2pcs washers K, using Allen wrench L. Note: Don't fully tighten the bolts.

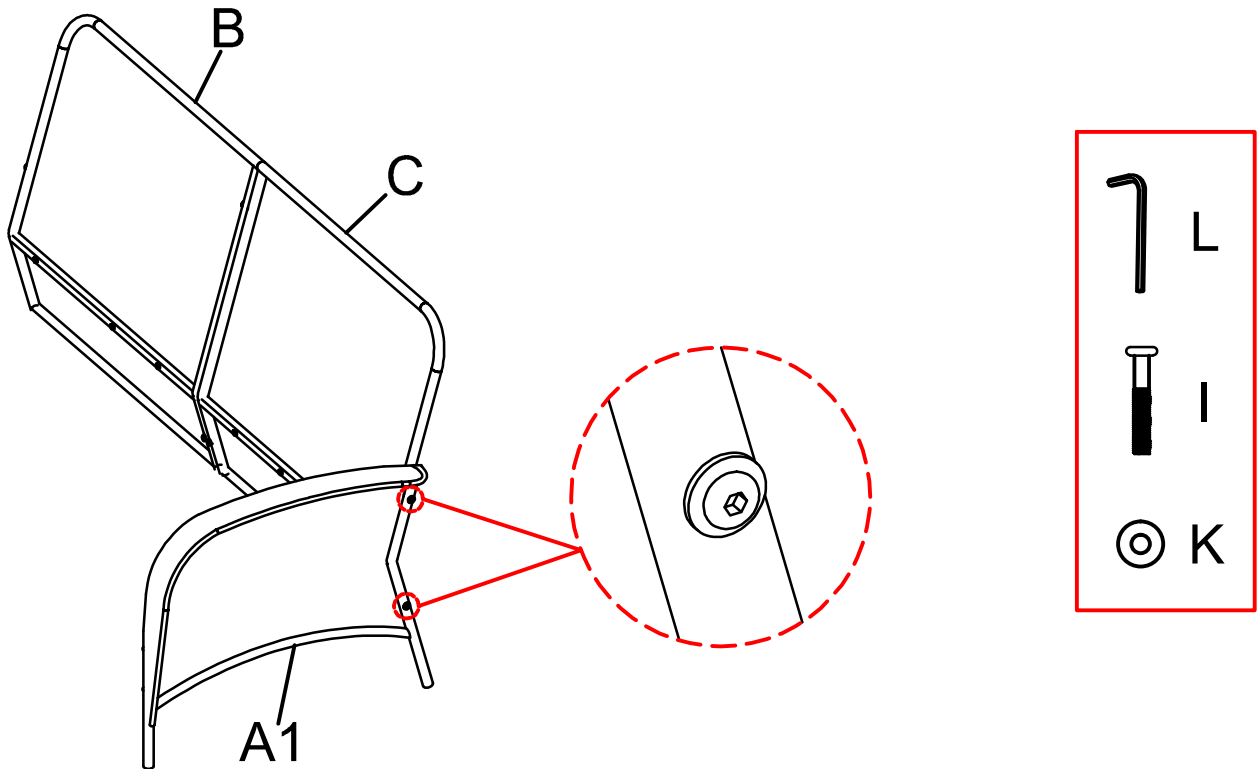

Step 4: Attach right arm A2 to back panel B with 2pcs bolts I and 2pcs washers K, using Allen wrench L. Note: Don't fully tighten the bolts.

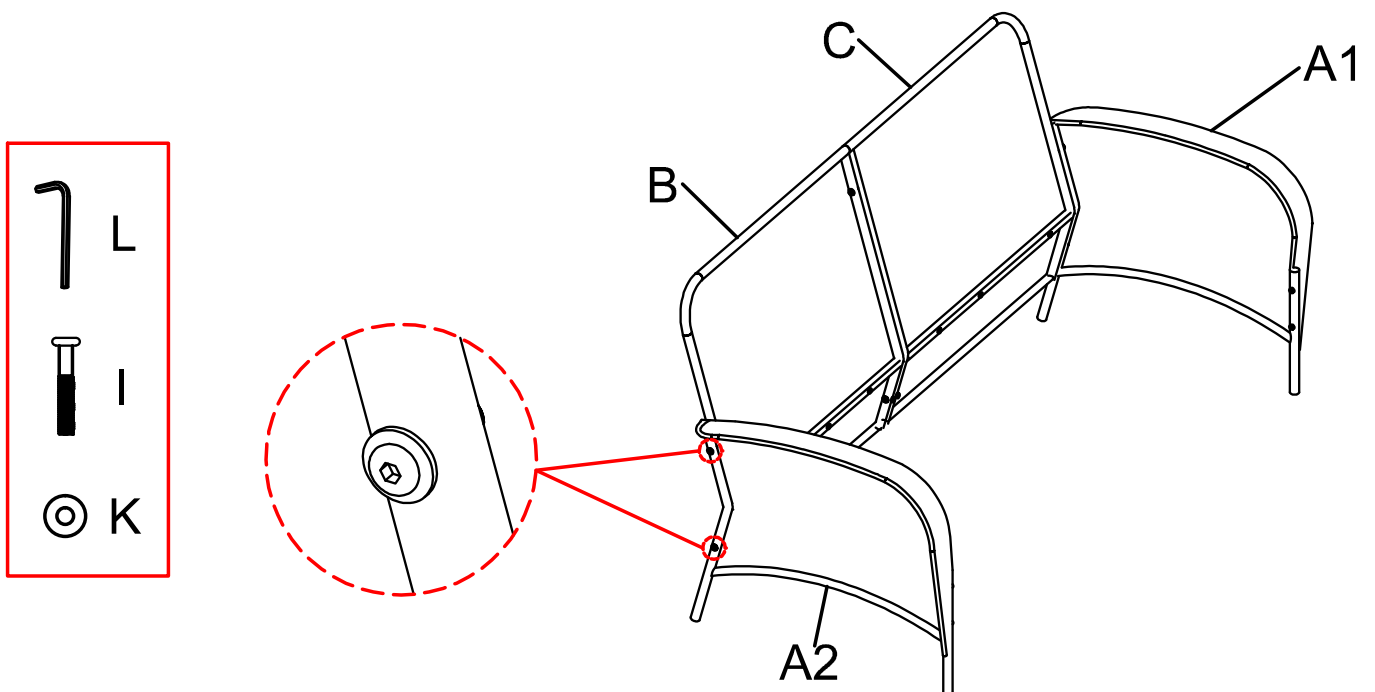

Step 5: Attach front panel D&F to arms A1&A2 with 4pcs bolts I and 4pcs washers K, using Allen wrench L. Note: Don't fully tighten the bolts.

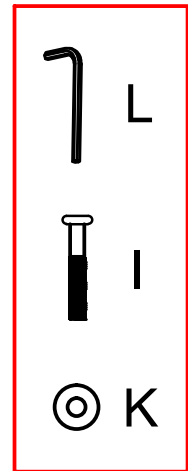
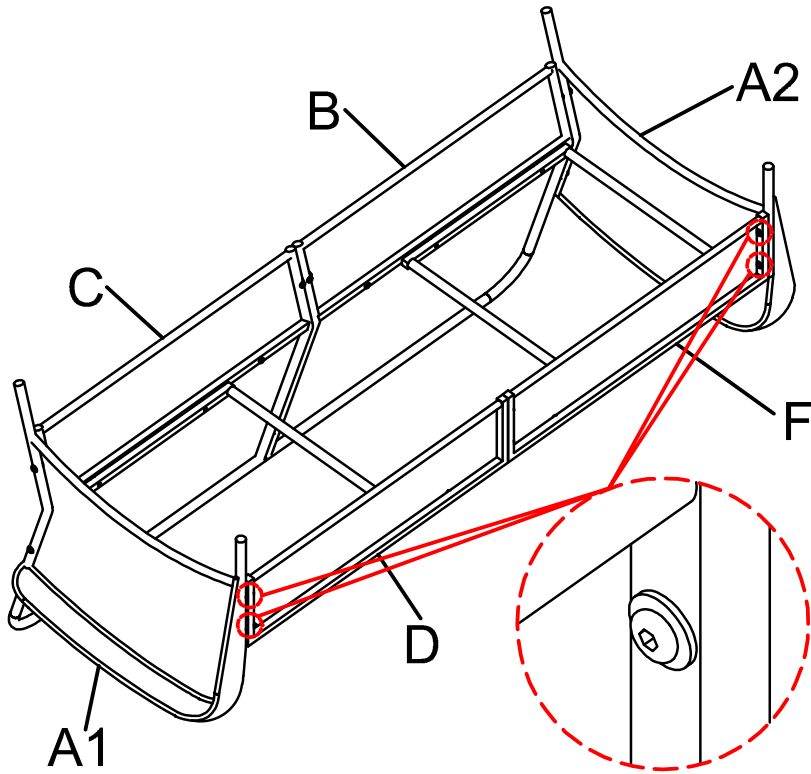

Step 6 : Attach middle foot G to back panels with 2pcs bolts I ,2pcs washers K and 1pc washer M , using Allen wrench L . Note: Don't fully tighten the bolts.

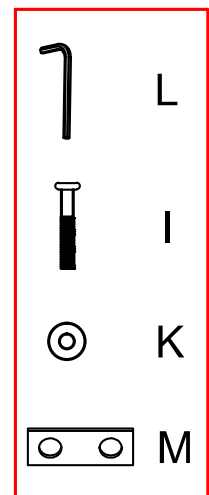
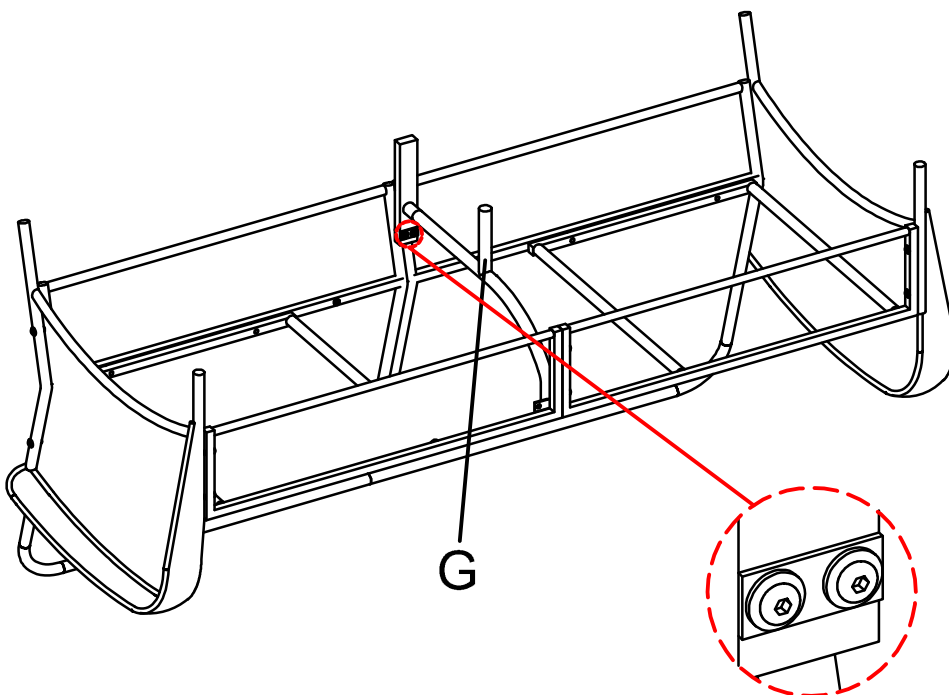

Step 7: Attach Middle foot G to Middle seat E with 2pcs bolts H and 2pcs washers K, using Allen wrench L. Note: Don't fully tighten the bolts.

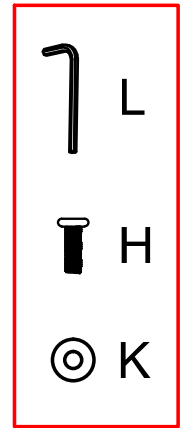
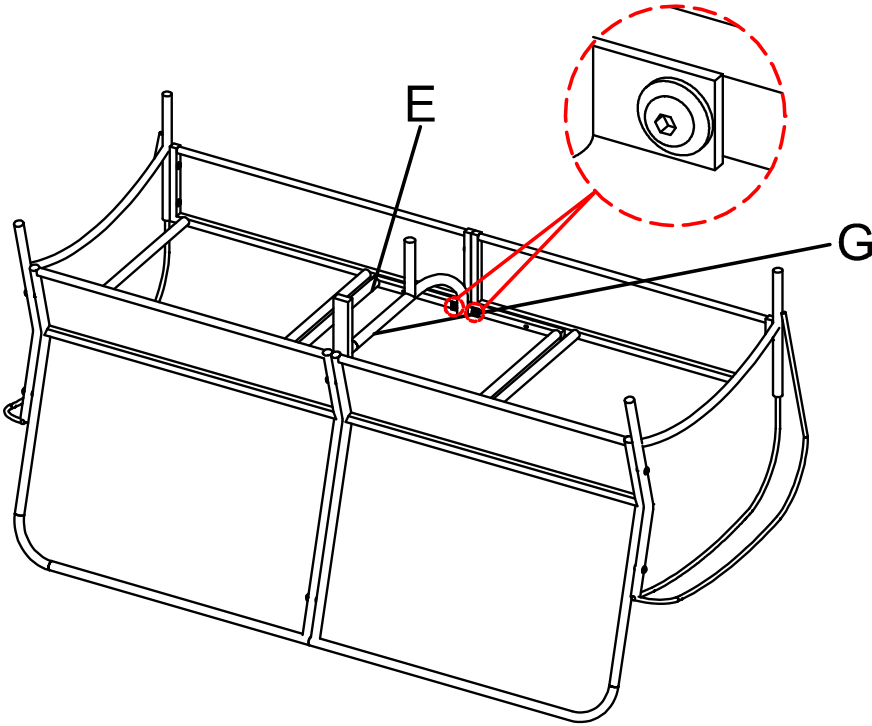

Step 8: Attach middle seat E to front panel with 2pcs bolts I and 2pcs washers K, using Allen wrench L. Note: Don't fully tighten the bolts.

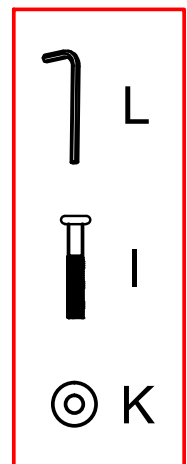
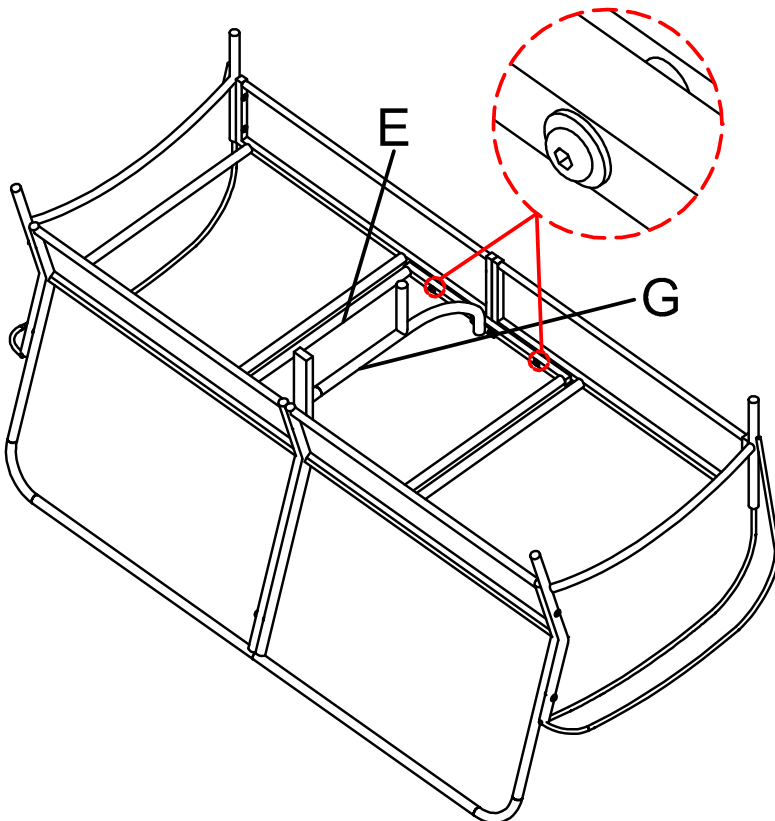

Step 9: Attach seat to back panel with 6pcs bolts I and 6pcs washers K ,using Allen wrench L. Note: Don't fully tighten the bolts.

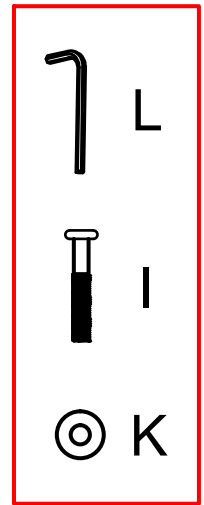
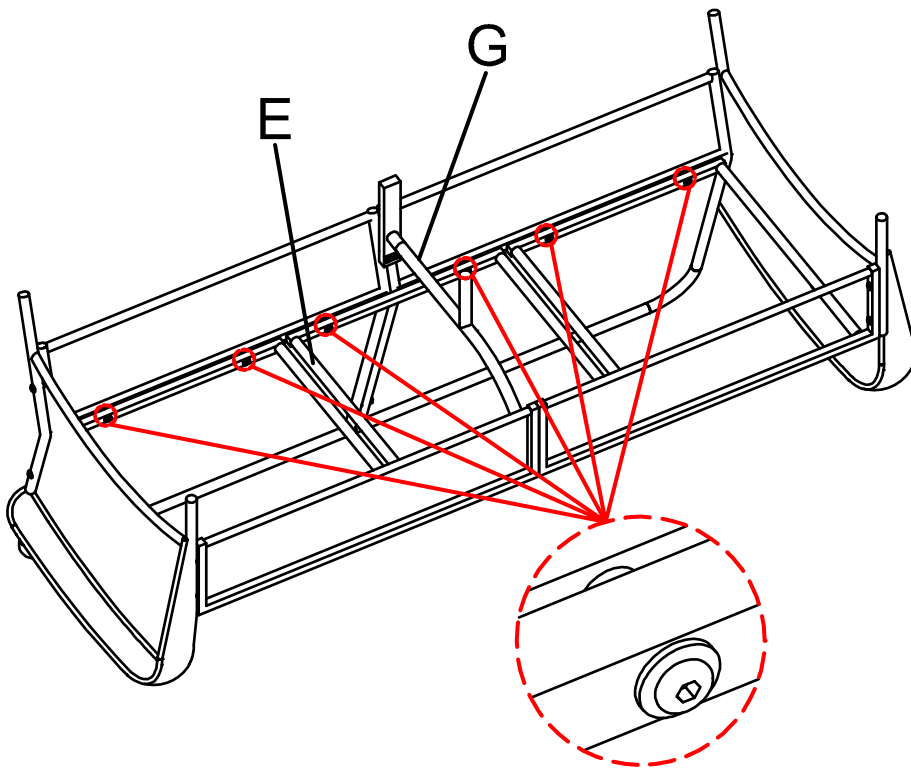

Step 10: Put seat cushion N and back cushion O onto the seat. Assembly is now complete and the product is ready for use.

