

**Sectional**  
**Canapé Modulaire**  
**Sofá de Tres Cuerpos**

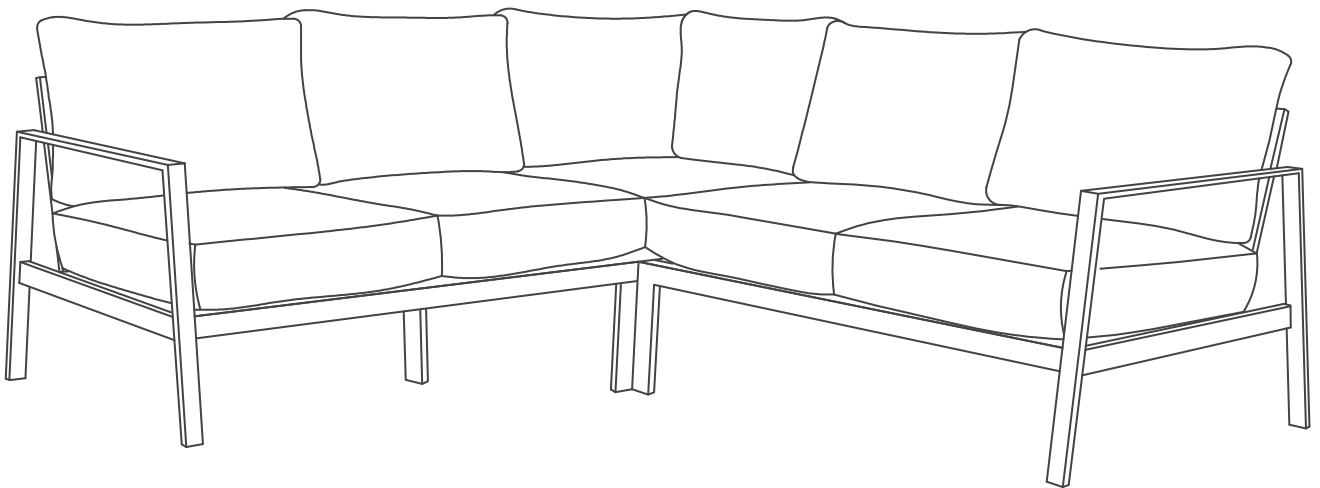

**PART LIST / LISTE DES PIÈCES / LISTAS DE PIEZAS**

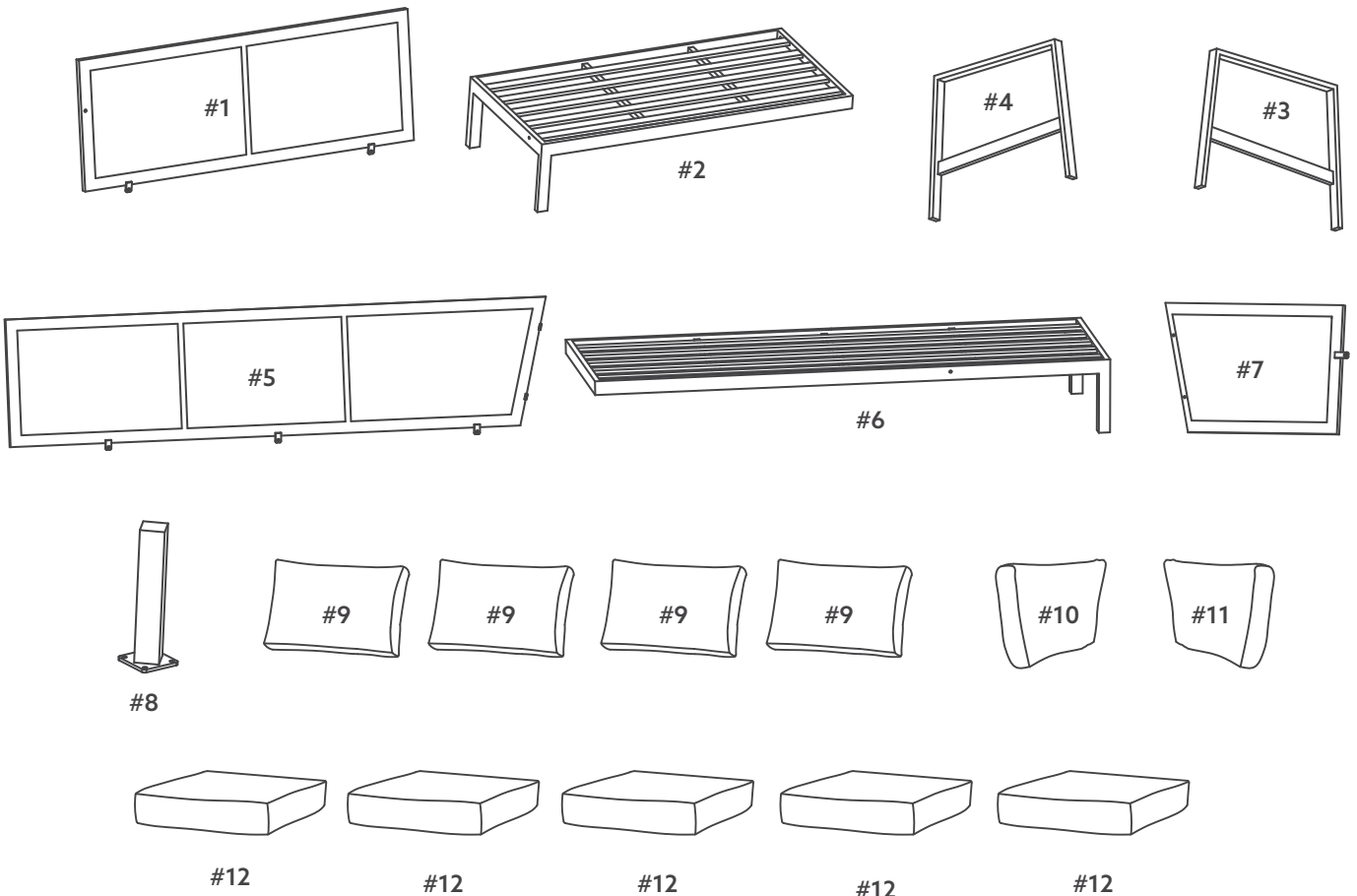

**SPARE PARTS - AVAILABLE FOR REPLACEMENT**

PIÈCES DE RECHANGE - DISPONIBLES POUR REMPLACEMENT

PIEZAS DE REPUESTO - DISPONIBLES PARA REMPLAZO

21026BLK01U-#3-JIW	ARMREST - LEFT / ACCOUDOIR - GAUCHE / APOYABRAZOS - IZQUIERDA	01
21026BLK01U-#4-JIW	ARMREST - RIGHT / ACCOUDOIR - DROITE / APOYABRAZOS - DERECHA	01
21026BLK01U-#8-JIW	SUPPORT LEG / PIED DE SUPPORT / PATA DE SOPORTE	01
21026BLK01U-#0-JIW	HARDWARE PACK / PAQUET CONTENANT LA QUINCAILLERIE / JUEGO DE HERRAMIENTAS	01
21026NAT01U-#3-JIW	ARMREST - LEFT / ACCOUDOIR - GAUCHE / APOYABRAZOS - IZQUIERDA	01
21026NAT01U-#4-JIW	ARMREST - RIGHT / ACCOUDOIR - DROITE / APOYABRAZOS - DERECHA	01
21026NAT01U-#8-JIW	SUPPORT LEG / PIED DE SUPPORT / PATA DE SOPORTE	01
21026NAT01U-#0-JIW	HARDWARE PACK / PAQUET CONTENANT LA QUINCAILLERIE / JUEGO DE HERRAMIENTAS	01

---







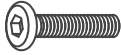

# SPARE PARTS - NOT AVAILABLE FOR REPLACEMENT

PIÈCES DE RECHANGE - NON DISPONIBLES POUR REMPLACEMENT

PIEZAS DE REPUESTO - NO DISPONIBLES PARA REMPLAZO

21026BLK01U-#1-JIW	BACK - LEFT / DOSSIER - GAUCHE / RESPALDO - IZQUIERDA	01
21026BLK01U-#2-JIW	SEAT - LEFT / SIÈGE - GAUCHE / ASIENTO - IZQUIERDA	01
21026BLK01U-#5-JIW	BACK - RIGHT / DOSSIER - DROITE / RESPALDO - DERECHA	01
21026BLK01U-#6-JIW	SEAT - RIGHT / SIÈGE - DROITE / ASIENTO - DERECHA	01
21026BLK01U-#7-JIW	BACK - CORNER / DOSSIER - COIN / RESPALDO - ESQUINERO	01
21026BLK01U-#9-JIW	CUSHION BACK / DOSSIER REMBOURRÉ / RESPALDO ACOLCHADO	04
21026BLK01U-#10-JIW	CUSHION BACK / DOSSIER REMBOURRÉ / RESPALDO ACOLCHADO	01
21026BLK01U-#11-JIW	CUSHION BACK / DOSSIER REMBOURRÉ / RESPALDO ACOLCHADO	01
21026BLK01U-#12-JIW	CUSHION SEAT / SIÈGE REMBOURRÉ / ASIENTO ACOLCHADO	05
21026NAT01U-#1-JIW	BACK - LEFT / DOSSIER - GAUCHE / RESPALDO - IZQUIERDA	01
21026NAT01U-#2-JIW	SEAT - LEFT / SIÈGE - GAUCHE / ASIENTO - IZQUIERDA	01
21026NAT01U-#5-JIW	BACK - RIGHT / DOSSIER - DROITE / RESPALDO - DERECHA	01
21026NAT01U-#6-JIW	SEAT - RIGHT / SIÈGE - DROITE / ASIENTO - DERECHA	01
21026NAT01U-#7-JIW	BACK - CORNER / DOSSIER - COIN / RESPALDO - ESQUINERO	01
21026NAT01U-#9-JIW	CUSHION BACK / DOSSIER REMBOURRÉ / RESPALDO ACOLCHADO	04
21026NAT01U-#10-JIW	CUSHION BACK / DOSSIER REMBOURRÉ / RESPALDO ACOLCHADO	01
21026NAT01U-#11-JIW	CUSHION BACK / DOSSIER REMBOURRÉ / RESPALDO ACOLCHADO	01
21026NAT01U-#12-JIW	CUSHION SEAT / SIÈGE REMBOURRÉ / ASIENTO ACOLCHADO	05

## HARDWARE LIST / LISTE DES PIÈCES / LISTAS DE PIEZAS

A		BOLT / BOULON / PERNO (Ø1/4" x 1-3/8")	06
B		BOLT / BOULON / PERNO (Ø1/4" x 3/4")	16
C		BOLT / BOULON / PERNO (Ø1/4" x 2-3/16")	01
D		FLAT WASHER / RONDELLE PLATE / ARANDELA PLANA	24
E		SPRING WASHER / RONDELLE À RESORT / ARANDELA DE MUELLE	24
F		PVC BOIT COVER / COUVERCLE EN PVC / CUBIERTA DE BOIT DE PVC	23
G		NUT / ÉCROU / TUERCA	01
H		CAP / SOMMET / CIMA	01



**NOTE:** Find the label of "Hardware Enclosed" on one of the carton corner then follow the red ribbon to get the hardware bag.

**REMARQUE:** Repérez l'étiquette «Quincaillerie Incluse» sur le coin de la boîte, puis suivez le ruban rouge pour récupérer le sac contenant la quincaillerie.

**NOTA:** Busque la etiqueta "Ferretería Incluida" en una de las esquinas de la caja, luego siga la cinta roja para recuperar la bolsa que contiene la tornillería.

---

## TOOLS REQUIRED / OUTILS REQUIS / HERRAMIENTAS REQUERIDAS

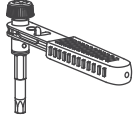
ALLEN KEY / CLÉ HEXAGONALE / LLAVE ALLEN		SUPPLIED / FOURNI / INCLUIDO
OPEN SPANNER / OPEN CLÉ / LLAVE ABIERTA		SUPPLIED / FOURNI / INCLUIDO
RATCHET / CLÉ À CLIQUET / LLAVE DE TRINQUETE		SUPPLIED / FOURNI / INCLUIDO

### IMPORTANT:

1. Do not tighten bolts completely until all bolts are completely lined up and inserted into holes / nuts.
2. Do not over tighten screws and bolts to avoid stripping.
3. Please use hand tools to assemble this product. Do not use power tools.
4. For ease of assembly, two adults are recommended

### IMPORTANT:

1. Ne serrez pas complètement les boulons jusqu'à ce que tous les boulons soient complètement alignés et insérés dans les trous / écrous.
2. Ne pas trop serrer les vis et les boulons pour éviter d'endommager les filets.
3. Utilisez des outils à main pour assembler ce produit. N'utilisez pas d'outils électriques.
4. L'assemblage par deux adultes est recommandé.

### IMPORTANTE:

1. No apriete completamente los pernos hasta que todos los tornillos estén alineados completamente y se inserten en los agujeros / tuercas.
2. No apriete demasiado los tornillos y los pernos para evitar dañar los filetes.
3. Utilice herramientas de mano para montar este producto. No utilice herramientas eléctricas.
4. Se recomienda el montaje por dos adultos.

# HOW TO USE RATCHET

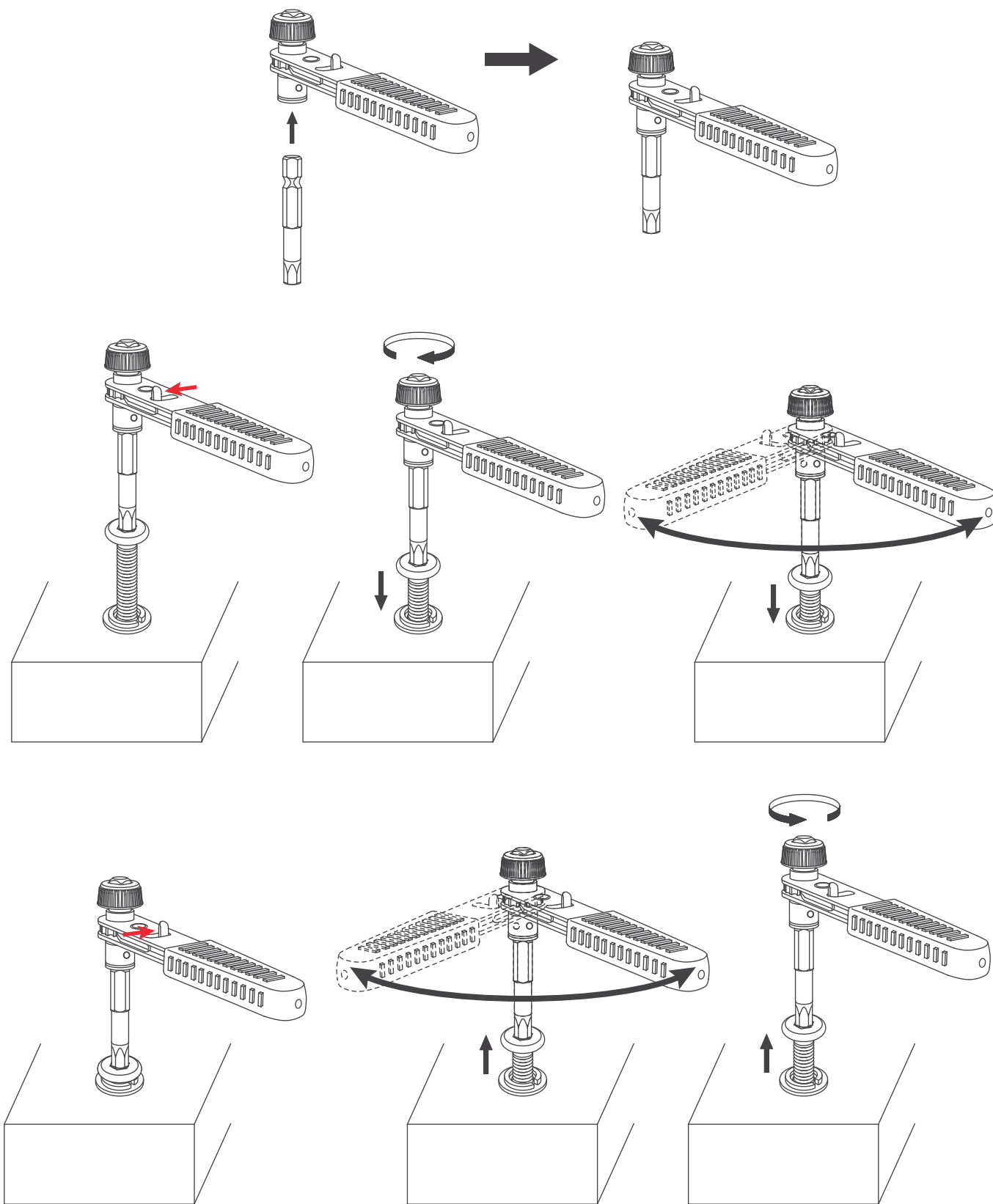

UTILISATION DE LA CLÉ À CLIQUET / UTILIZACIÓN DE LA LLAVE DE TRINQUETE

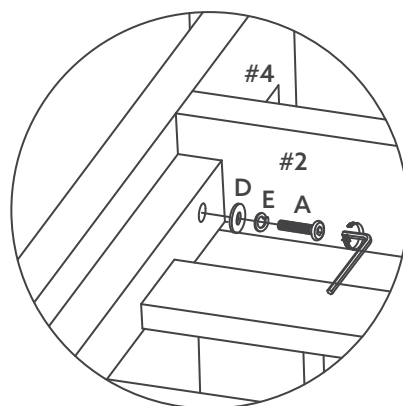
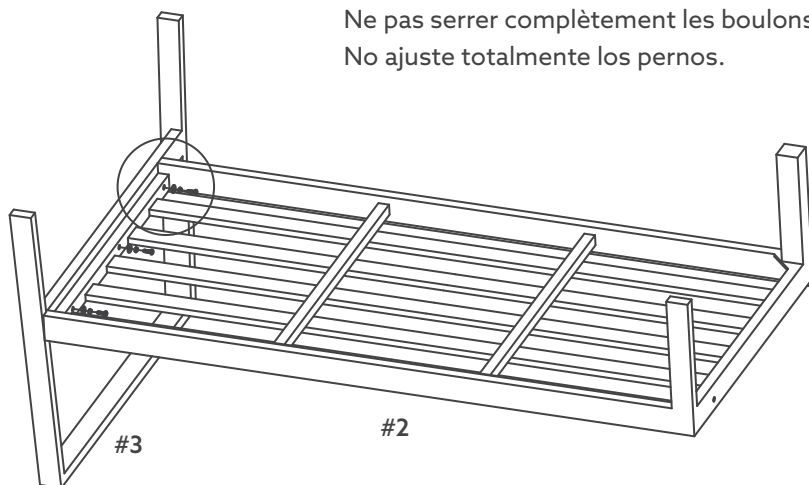

1.

**Do not fully tighten the bolts.**  
 Ne pas serrer complètement les boulons.  
 No ajuste totalmente los pernos.

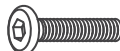



A		03
D		03
E		03

2.

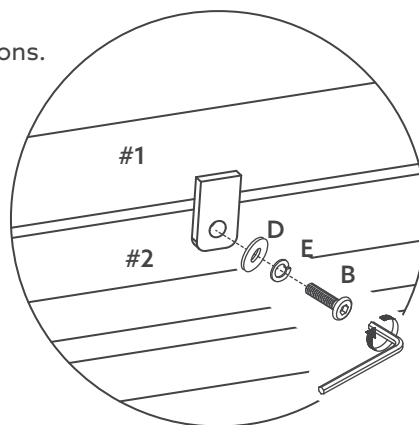
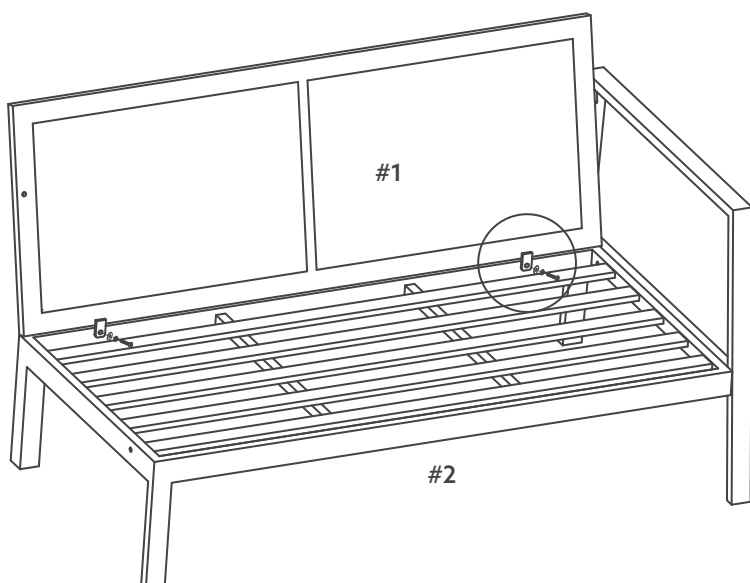
**Do not fully tighten the bolts.**  
 Ne pas serrer complètement les boulons.  
 No ajuste totalmente los pernos.





B		02
D		02
E		02

3.

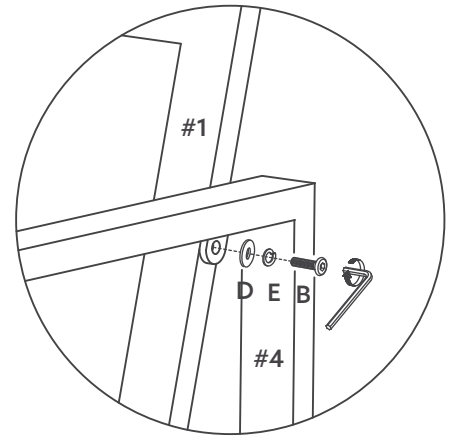
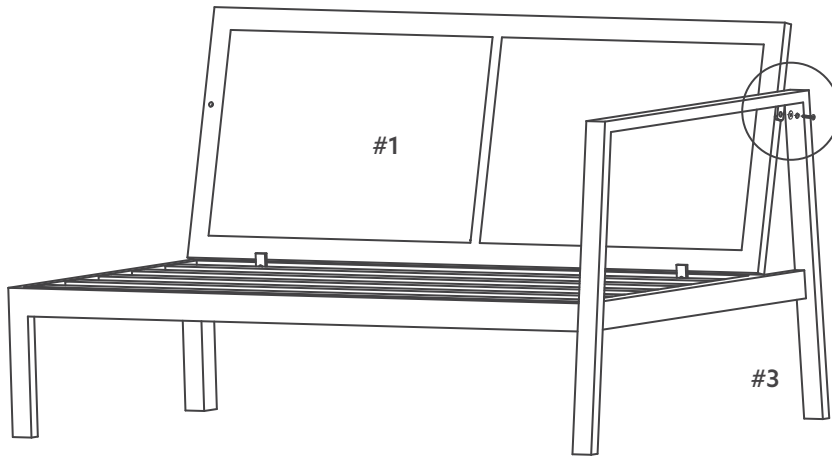
**Do not fully tighten the bolts.**  
 Ne pas serrer complètement les boulons.  
 No ajuste totalmente los pernos.





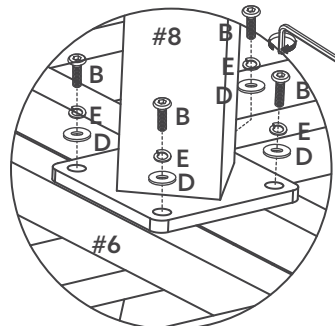
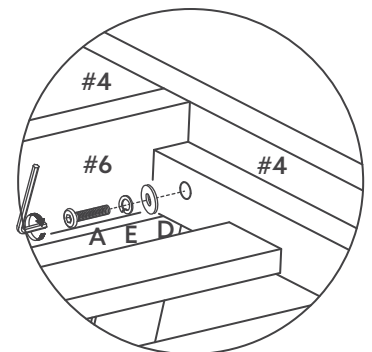
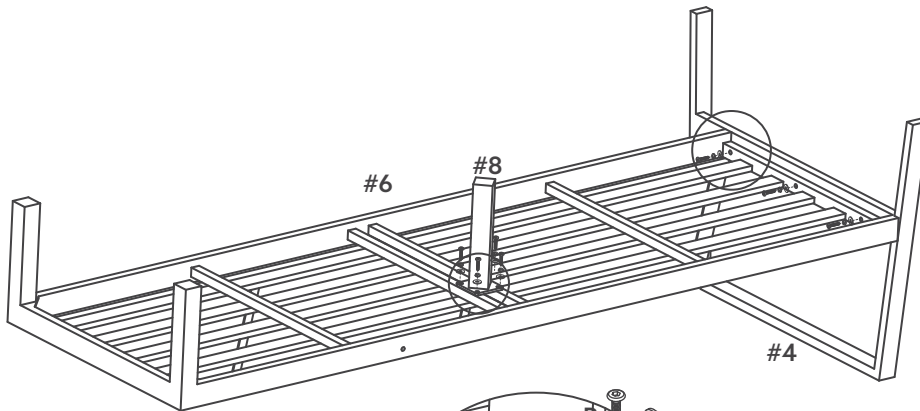

B		01
D		01
E		01

4.



**Do not fully tighten the bolts.**  
 Ne pas serrer complètement les boulons.  
 No ajuste totalmente los pernos.

A		03
B		04
D		07
E		07



5.

**Do not fully tighten the bolts.**

Ne pas serrer complètement les boulons.

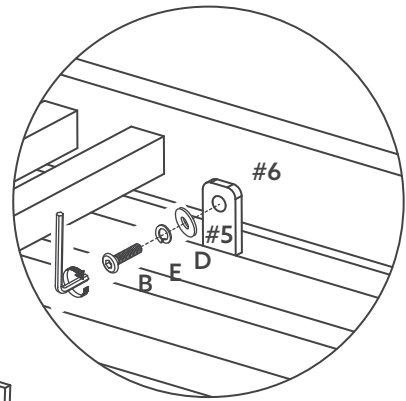
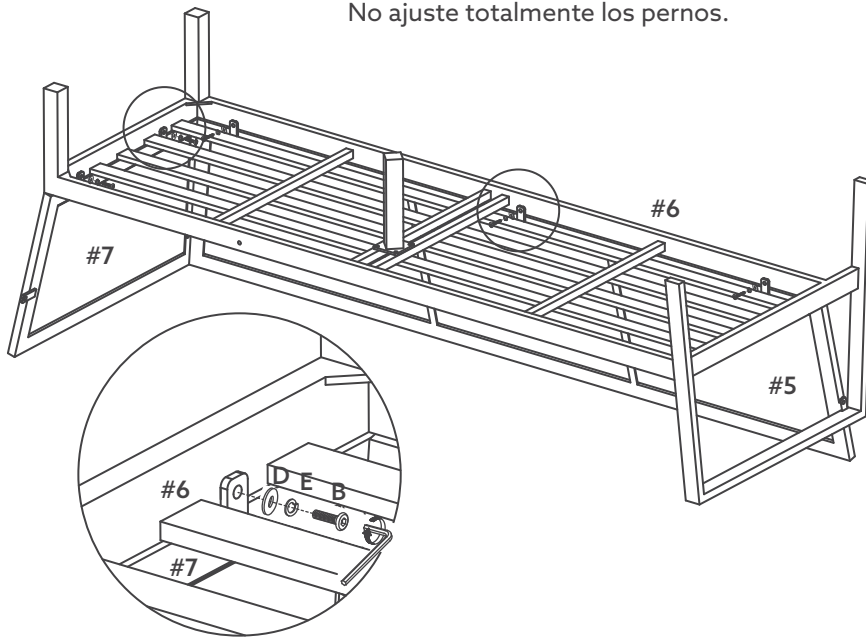
No ajuste totalmente los pernos.



B		05
D		05
E		05

6.

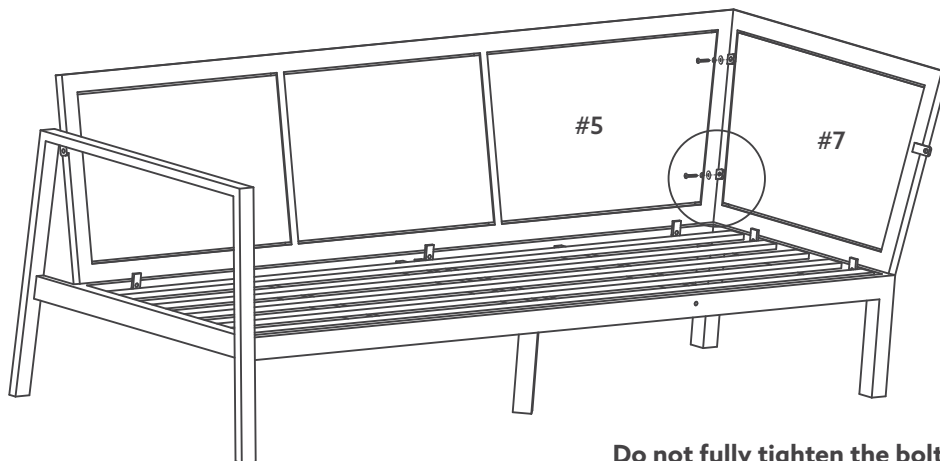



**Do not fully tighten the bolts.**

Ne pas serrer complètement les boulons.

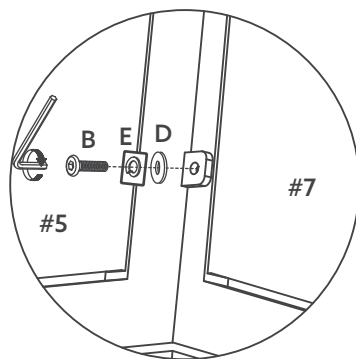



No ajuste totalmente los pernos.

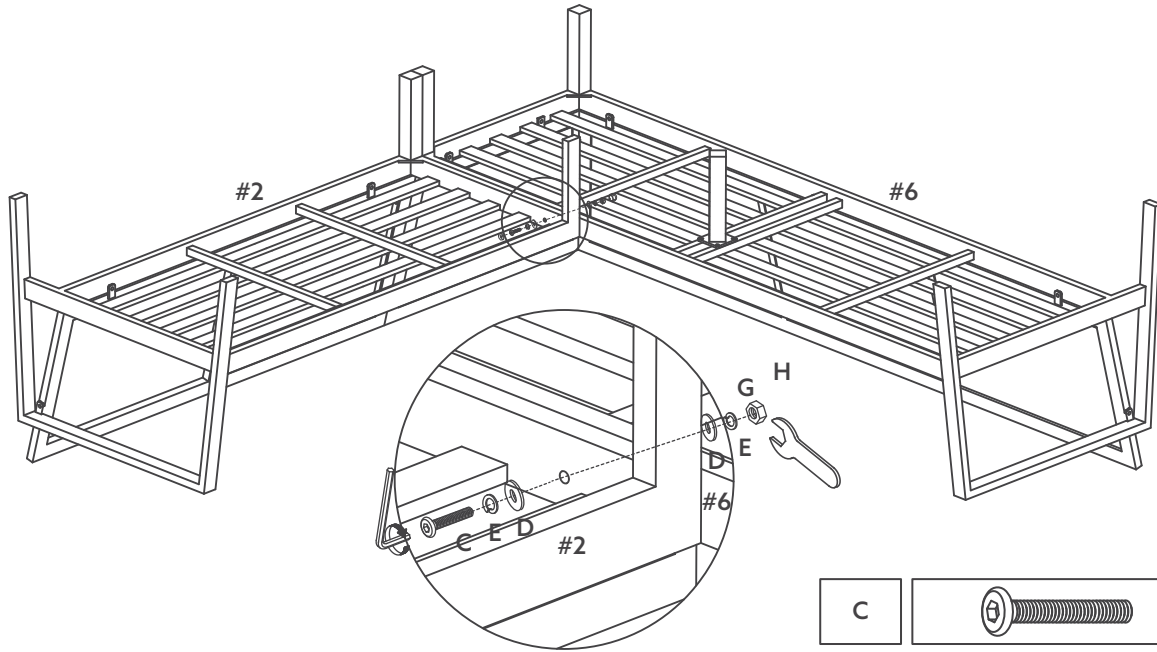

B		02
D		02
E		02



7.

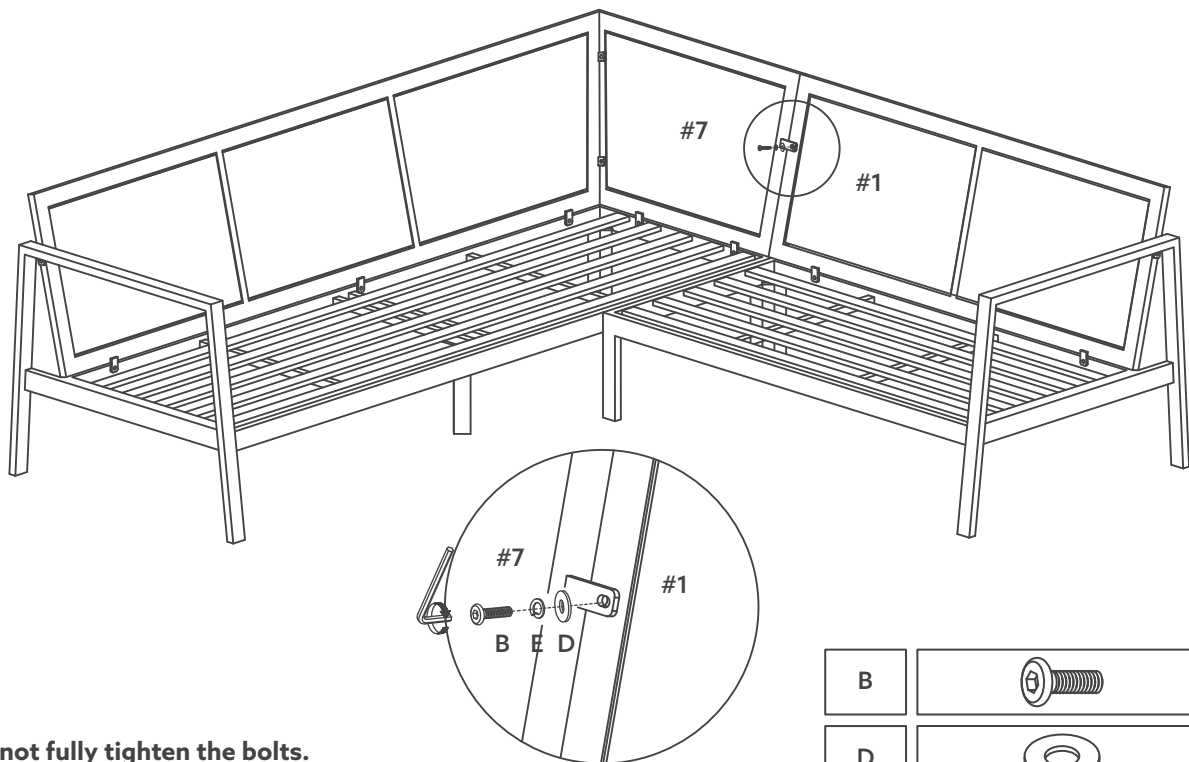

C		01
D		02
E		02
G		01

8.



B		01
D		01
E		01

**Do not fully tighten the bolts.**

Ne pas serrer complètement les boulons.

No ajuste totalmente los pernos.

9.

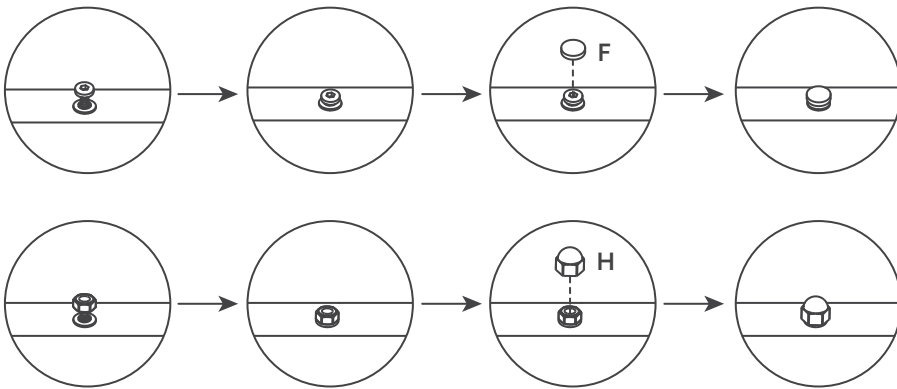
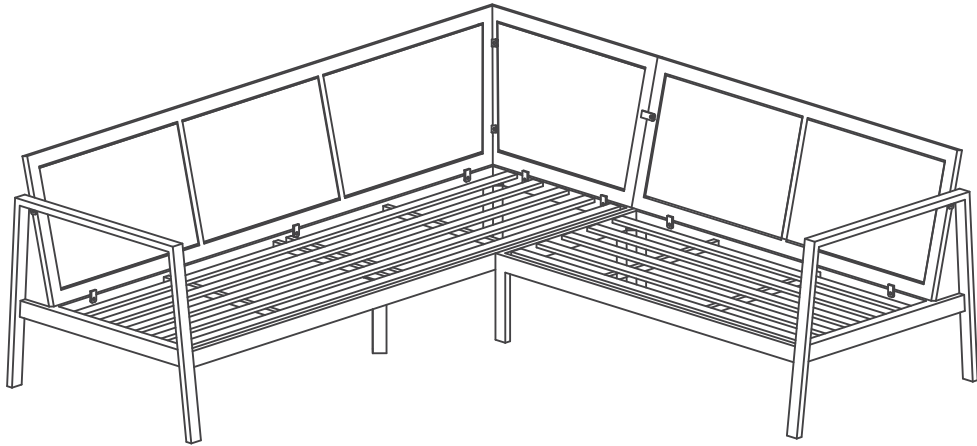

**Fully tighten all the bolts.**  
 Serrer complètement toutes les boulons.  
 Ajuste completamente todos los pernos.

F		23
H		01

10.

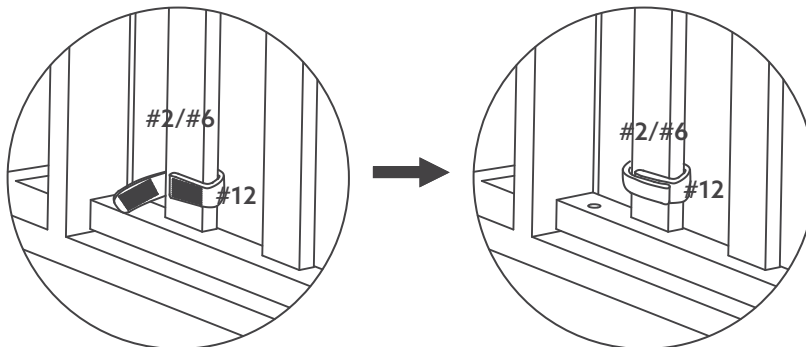
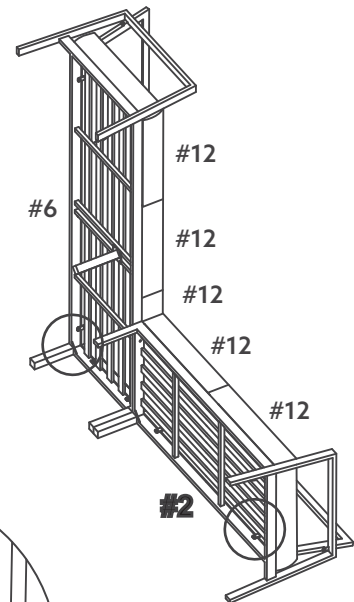
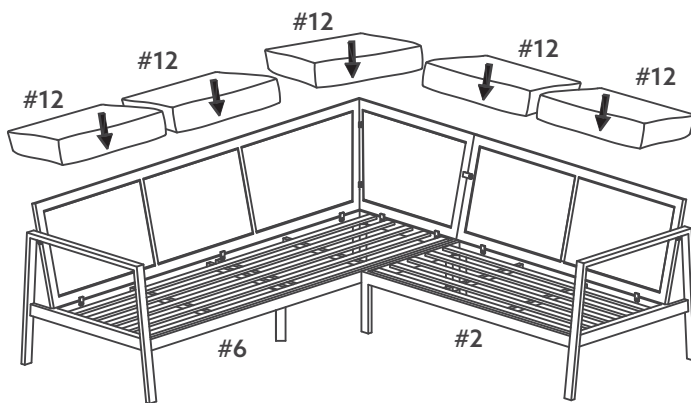

11.

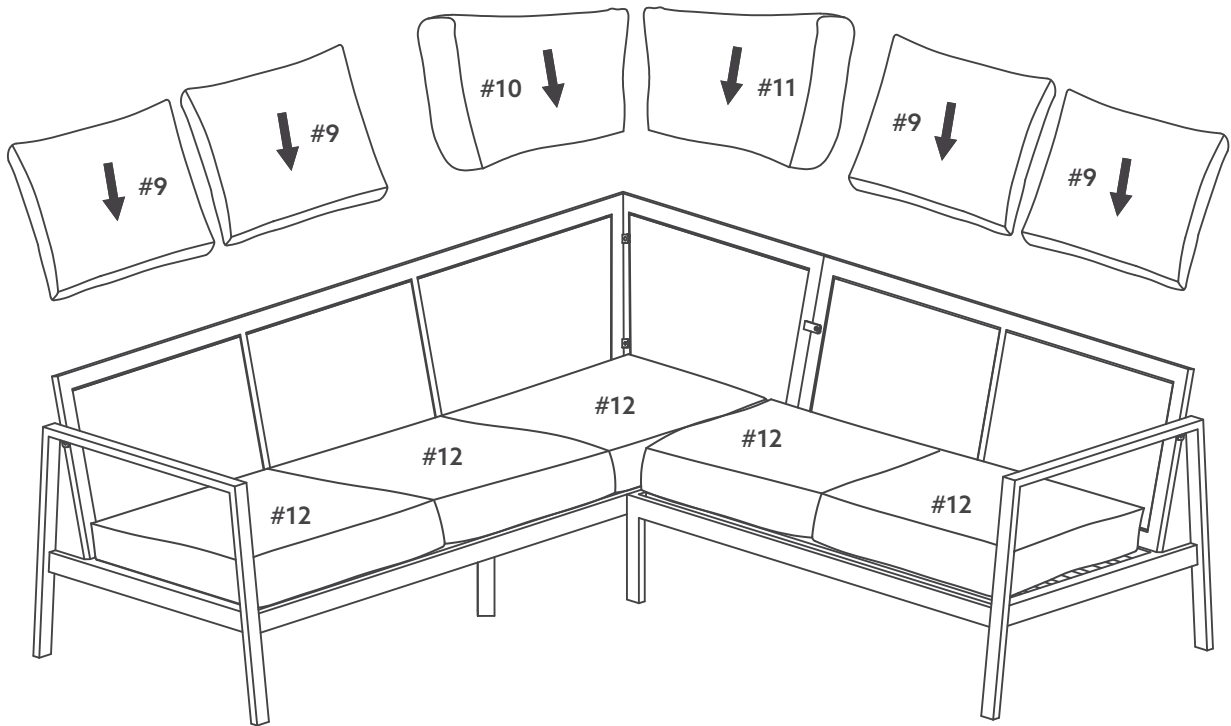

12.

**Maximum Weight 225 lbs**  
Poids maximum: 225 lb (102 kg)  
Peso máximo: 225 lb (102 kg)

**Maximum Weight 225 lbs**  
Poids maximum: 225 lb (102 kg)  
Peso máximo: 225 lb (102 kg)

**Maximum Weight 225 lbs**  
Poids maximum: 225 lb (102 kg)  
Peso máximo: 225 lb (102 kg)

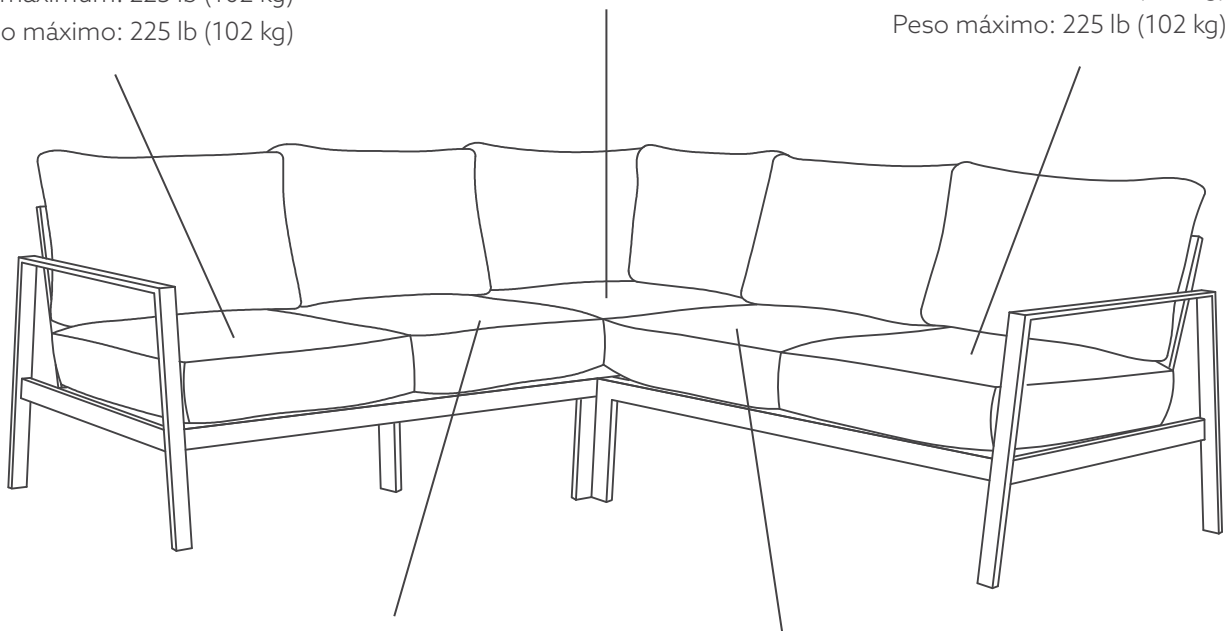

**Maximum Weight 225 lbs**  
Poids maximum: 225 lb (102 kg)  
Peso máximo: 225 lb (102 kg)

**Maximum Weight 225 lbs**  
Poids maximum: 225 lb (102 kg)  
Peso máximo: 225 lb (102 kg)