

Animal Cage

read first REVIEW BEFORE ASSEMBLY

- **TOOLS:** Allen wrench (included). Needle nose pliers (not included) may be useful. If using power tools, be careful not to over-tighten screws.

1 To assemble the **BASE**, you will need these pieces:

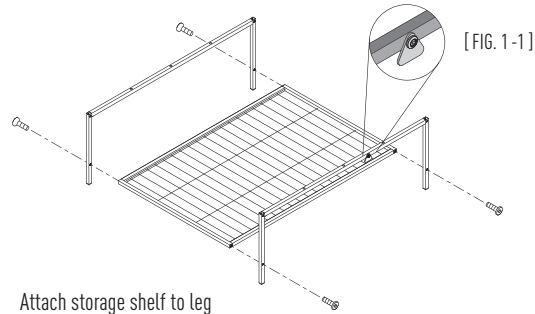
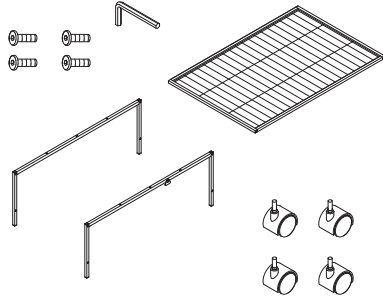

Attach storage shelf to leg frames. Windbell lock on front leg frame faces out (fig. 1-1).

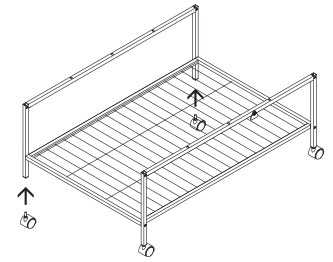

Flip unit over and fully insert casters into frame legs.

2 To assemble the **CAGE**, you will need these pieces:

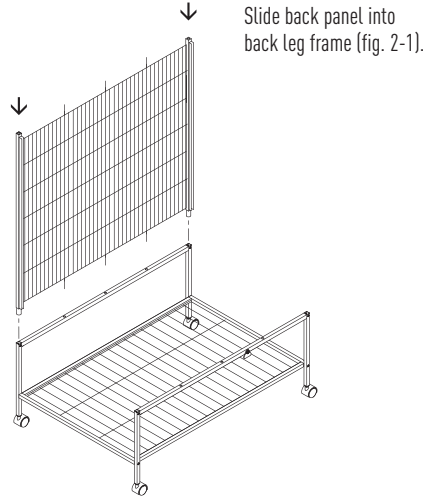
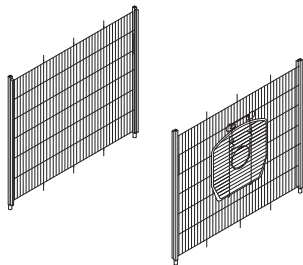

Slide back panel into back leg frame (fig. 2-1).

Slide front panel (with door) into front leg frame (fig. 2-1). If necessary, hole slugs may be removed and extended vertical wires may be straightened to align with holes in frame with needle nose pliers.

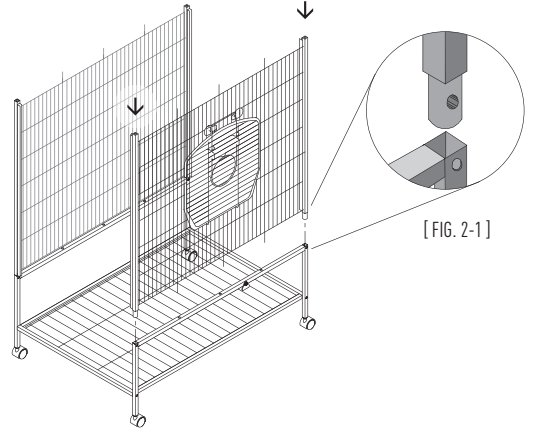

[FIG. 2-1]

3 To assemble the **CAGE SIDES**, you will need these pieces:

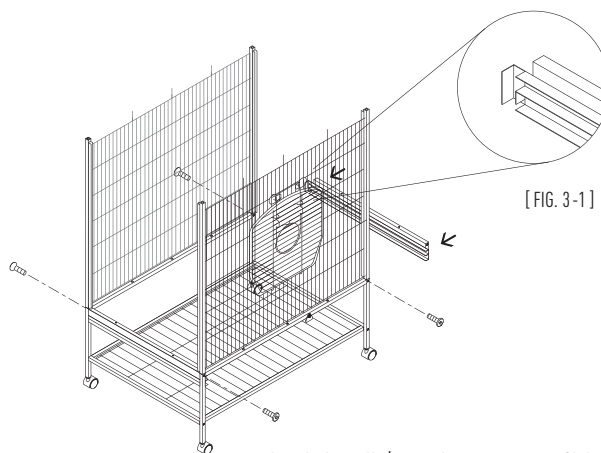
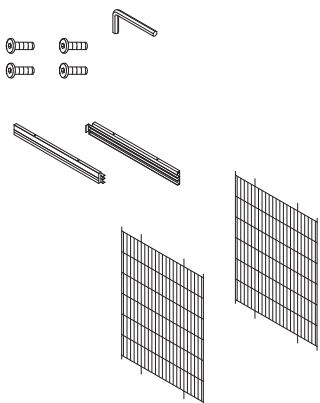

[FIG. 3-1]

Attach the grille/tray rails following the orientation shown in the detail (fig. 3-1).

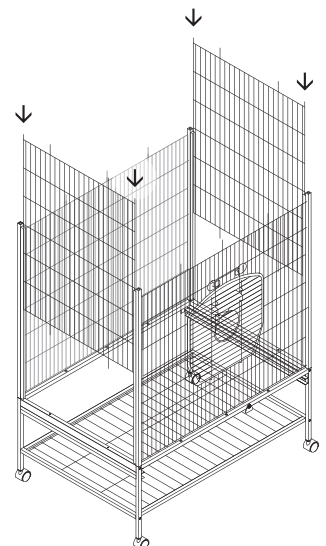

Slide side panels into place.

4

To install **PLATFORMS and RAMPS**, you will need these pieces:

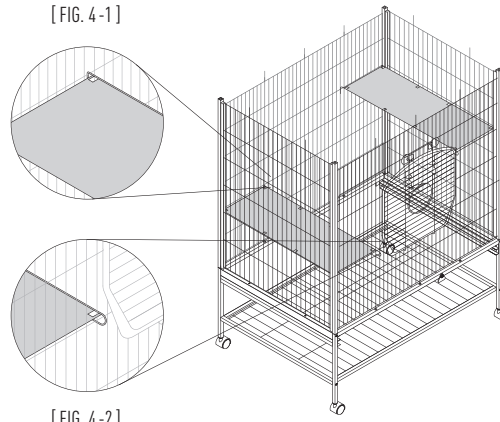
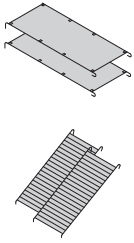

Hook the lower platform on second horizontal wire up from the bottom (fig. 4-1) (fig. 4-2). Hook the upper platform on second horizontal wire down from the top.

Orient ramps with ridges facing up, and 'U' hook ends at the top (fig. 4-3), 'L' hook ends at the bottom (fig. 4-4).

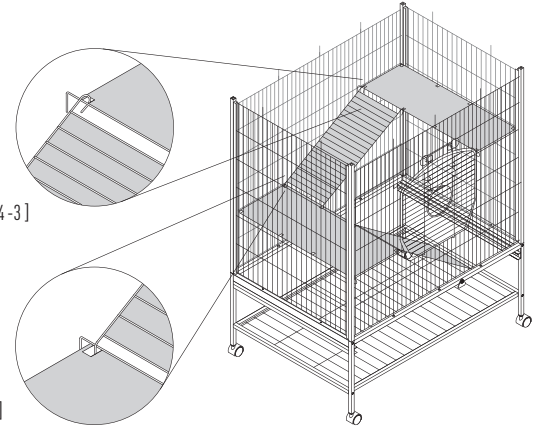

5

To attach the **ROOF**, you will need this piece:

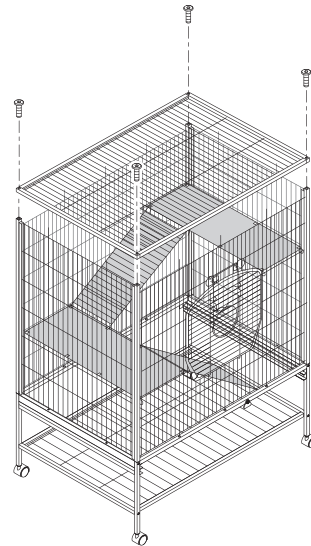
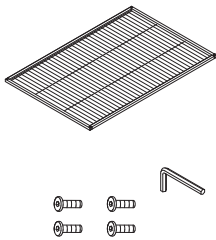

Position the roof panel over the top of the cage. Align wires and corner posts with receiving holes on underside of frame. Secure the roof in place with screws in each corner.

6

To finish installation with the **GRILLE and TRAY**, you will need these pieces:

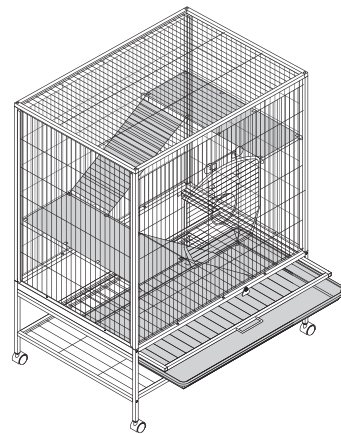
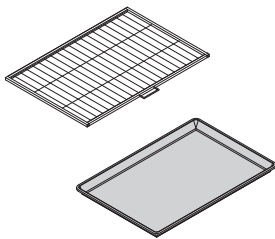

Your cage is assembled and ready for use!

