

To receive free replacement, Control No. and Proof-of-Purchase from an authorized dealer/retailer **MUST** be provided with request within 60 days from date of purchase. **Pour obtenir un remplacement gratuit**, le numéro de contrôle et la preuve d'achat auprès d'un concessionnaire/magasin autorisé **DOIVENT** être fournis avec une demande soumise dans les 60 jours suivant la date d'achat. **Para recibir un reemplazo gratis**, # de Control y prueba de compra de un comerciante/vendedor autorizado, **DEBE** ser recibido dentro de 60 días desde la fecha de compra.

Desk - Bureau - Escritorio

Missing parts request:

To obtain replacement part(s), fill in quantity in the "missing" box under the "Parts List" section. Complete contact and shipping information in address box accurately and clearly. Please allow 7-14 days for delivery.

Demande de pièces manquantes:

Pour obtenir une (des) pièce(s) de remplacement, remplissez la case « manquant » sous la section « Liste des pièces ». Fournissez vos coordonnées et informations d'expédition dans la case Adresse de manière claire et précise. La livraison aura lieu dans un délai de 7 à 14 jours.

Petición de partes perdidas:

Para obtener parte(s) de reemplazo, llené en número la cantidad en el cuadro de "missing" debajo de "Lista de partes" sección. Llené su información de contacto y envío en el cuadro de dirección clara y correcta. Por favor permita 7-14 días para envío.

Reason of replacement part(s) - Raison de(s) pièce(s) de remplacement - Razón del reemplazo la parte(s):

- Missing/Manquant/Ausente Provide Details/Fournis détails/Proporcionar detalles: _____
- Damaged/Endommagé/Dañado _____
- Not Fit/Ne rentre pas/No ajusta _____
- Other/Autre/Otro: _____

IMPORTANT!-IMPORTANT!-IMPORTANTE!

Please provide Control No. to ensure replacement parts properly fit unit on hand. Fournir N° de contrôle pour assurer que les pièces de rechange s'adaptent correctement à l'unité en question.

Favor de proporcionar el numero de control para garantizar que las piezas de reemplazo ajuste correctame su producto.

Control No.
N° de contrôle
de control

Name - Nom - Nombre

Address - Adresse - Dirección

City/State/Zip - Ville/Province/Code postal - Ciudad/Estado/Zona Postal

Phone - Téléphone - Teléfono

Email

Parts List - Liste des pièces - Lista de partes

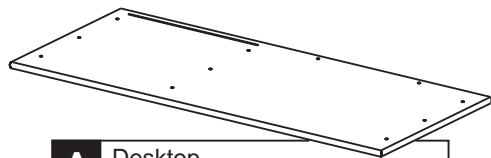

A	Desktop Dessus de bureau Tapa del escritorio	Quantity Quantité Cantidad	1	Missing Manquant Ausente	
----------	----------------------------------------------------	----------------------------------	---	--------------------------------	--

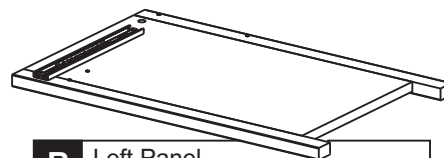

B	Left Panel Panneau gauche Costado izquierdo	Quantity Quantité Cantidad	1	Missing Manquant Ausente	
----------	---------------------------------------------------	----------------------------------	---	--------------------------------	--

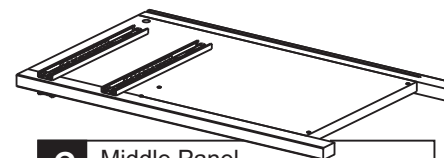

C	Middle Panel Panneau du milieu Panel medio	Quantity Quantité Cantidad	1	Missing Manquant Ausente	
----------	--------------------------------------------------	----------------------------------	---	--------------------------------	--

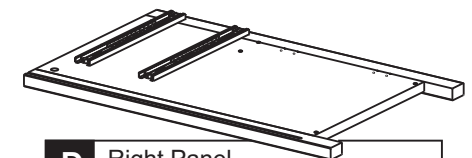

D	Right Panel Panneau droit Costado derecho	Quantity Quantité Cantidad	1	Missing Manquant Ausente	
----------	-------------------------------------------------	----------------------------------	---	--------------------------------	--

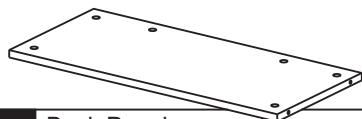

E	Back Panel Panneau arrière Panel posterior	Quantity Quantité Cantidad	1	Missing Manquant Ausente	
----------	--------------------------------------------------	----------------------------------	---	--------------------------------	--



F	Back Board Planche arrière Tabla trasera	Quantity Quantité Cantidad	1	Missing Manquant Ausente	
----------	------------------------------------------------	----------------------------------	---	--------------------------------	--



G	Support (Long) Cadre support (long) Marco de soporte (larga)	Quantity Quantité Cantidad	1	Missing Manquant Ausente	
----------	--------------------------------------------------------------------	----------------------------------	---	--------------------------------	--



H	Support (Short) Cadre support (court) Marco de soporte (corto)	Quantity Quantité Cantidad	1	Missing Manquant Ausente	
----------	----------------------------------------------------------------------	----------------------------------	---	--------------------------------	--

To receive free replacement, Control No. and Proof-of-Purchase from an authorized dealer/retailer MUST be provided with request within 60 days from date of purchase. **Pour obtenir un remplacement gratuit**, le numéro de contrôle et la preuve d'achat auprès d'un concessionnaire/magasin autorisé DOIVENT être fournis avec une demande soumise dans les 60 jours suivant la date d'achat. **Para recibir un reemplazo gratis**, # de Control y prueba de compra de un comerciante/vendedor autorizado, DEBE ser recibido dentro de 60 días desde la fecha de compra.

Desk - Bureau - Escritorio

IMPORTANT!-IMPORTANT!-IMPORTANTE!

Please provide Control No. to ensure replacement parts properly fit unit on hand.
Fournir N° de contrôle pour assurer que les pièces de rechange s'adaptent correctement à l'unité en question.

Favor de proporcionar el numero de control para garantizar que las piezas de reemplazo ajuste correctame su producto

Control No.
N° de contrôle
de control

Name - Nom - Nombre

Address - Adresse - Dirección

City/State/Zip - Ville/Province/Code postal - Ciudad/Estado/Zona Postal

Phone - Téléphone - Teléfono

Email

Reason of replacement part(s) - Raison de(s) pièce(s) de remplacement - Razón del reemplazo la parte(s):

- Missing/Manquant/Ausente
 Damaged/Endommagé/Dañado
 Not Fit/Ne rentre pas/No ajusta
 Other/Autre/Otro:

Provide Details/Fournis détails/Proporcionar detalles:

Parts List - Liste de pièces - Lista de partes

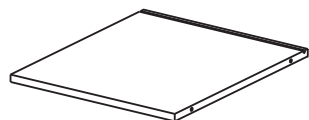

I	Bottom Panel Panneau inférieur Panel inferior
Quantity Quantité Cantidad	1 <i>Missing Manquant Ausente</i>

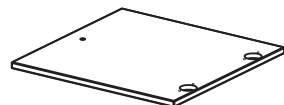

J	Door Porte Puerta
Quantity Quantité Cantidad	1 <i>Missing Manquant Ausente</i>

(Drawer - Tirior - Cajón)

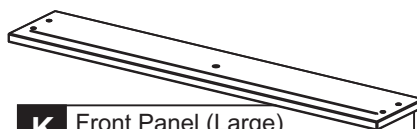

K	Front Panel (Large) Panneau Avant (grand) Panel de enfrente (grande)
Quantity Quantité Cantidad	1 <i>Missing Manquant Ausente</i>

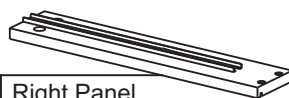

N	Right Panel Panneau droit Panel derecho
Quantity Quantité Cantidad	3 <i>Missing Manquant Ausente</i>

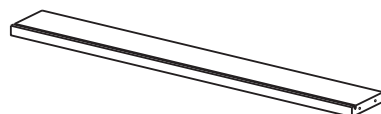

Q	Back Panel (Large) Panneau arrière (grand) Panel posterior (grande)
Quantity Quantité Cantidad	1 <i>Missing Manquant Ausente</i>

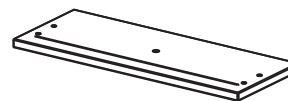

L	Front Panel (Medium) Panneau Avant (moyen) Panel de enfrente (mediano)
Quantity Quantité Cantidad	1 <i>Missing Manquant Ausente</i>

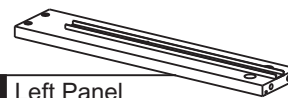

O	Left Panel panneau gauche panel izquierda
Quantity Quantité Cantidad	3 <i>Missing Manquant Ausente</i>

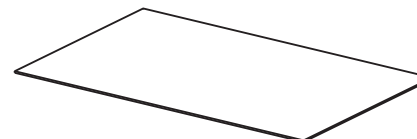

R	Bottom Board (Large) Planche inférieure (grand) Tabla de abajo (grande)
Quantity Quantité Cantidad	1 <i>Missing Manquant Ausente</i>

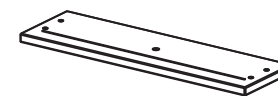

M	Front Panel (Small) Panneau Avant (petit) Panel de enfrente (pequeño)
Quantity Quantité Cantidad	1 <i>Missing Manquant Ausente</i>

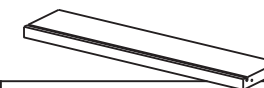

P	Back Panel (Small) Panneau Arrière (petit) Panel de atrás (pequeño)
Quantity Quantité Cantidad	2 <i>Missing Manquant Ausente</i>

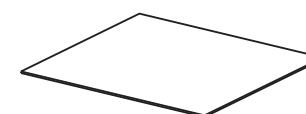

S	Bottom Board (Small) Planche inférieure (petit) Tabla de abajo (pequeño)
Quantity Quantité Cantidad	2 <i>Missing Manquant Ausente</i>

To receive free replacement, Control No. and Proof-of-Purchase from an authorized dealer/retailer MUST be provided with request within 60 days from date of purchase. **Pour obtenir un remplacement gratuit**, le numéro de contrôle et la preuve d'achat auprès d'un concessionnaire/magasin autorisé DOIVENT être fournis avec une demande soumise dans les 60 jours suivant la date d'achat. **Para recibir un reemplazo gratis**, # de Control y prueba de compra de un comerciante/vendedor autorizado, DEBE ser recibido dentro de 60 días desde la fecha de compra.

Desk - Bureau - Escritorio

IMPORTANT!-IMPORTANT!-IMPORTANTE!

Please provide Control No. to ensure replacement parts properly fit unit on hand.

Fournir N° de contrôle pour assurer que les pièces de rechange s'adaptent correctement à l'unité en question.

Favor de proporcionar el numero de control para garantizar que las piezas de reemplazo ajuste correctame su producto

Control No.
N° de contrôle
de control

Name - Nom - Nombre

Address - Adresse - Dirección

City/State/Zip - Ville/Province/Code postal - Ciudad/Estado/Zona Postal

Phone - Téléphone - Teléfono

Email

Reason of replacement part(s) - Raison de(s) pièce(s) de remplacement - Razón del reemplazo la parte(s):

- Missing/Manquant/Ausente
 Damaged/Endommagé/Dañado
 Not Fit/Ne rentre pas/No ajusta
 Other/Autre/Otro:

Provide Details/Fournis détails/Proporcionar detalles:

Parts List - Liste de pièces - Lista de partes



T	Door Hinge Charnière de porte Bisagra del puerta			
Quantity Quantité Cantidad	2	Missing Manquant Ausente		



U	Cam Lock* Serrure batteuse* Cam-lock*			
Quantity Quantité Cantidad	39	Missing Manquant Ausente		

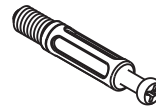

V	Cam Lock Screw* Vis à blocage rapide* Tornillo para cam-lock*			
Quantity Quantité Cantidad	39	Missing Manquant Ausente		



W	Screw* (Phillips) Vis* (Phillips) Tornillo* (Phillips)			
Quantity Quantité Cantidad	12	Missing Manquant Ausente		



X	Small Screw* (Phillips) Petite vis* (Phillips) Tornillo Pequeño* (Phillips)			
Quantity Quantité Cantidad	12	Missing Manquant Ausente		



Y	Bolt* Boulon* Tornillo de metal*			
Quantity Quantité Cantidad	4	Missing Manquant Ausente		



Z	Knob Bouton Perilla			
Quantity Quantité Cantidad	4	Missing Manquant Ausente		

* Screw Driver is required and not included in the package.

* Un tournevis est nécessaire mais n'est pas inclus avec cet ensemble.

* Se requiere desarmador de cruz y no viene incluido.

Care instructions:

To clean, wipe with wet cloth and dry thoroughly.

Use mild soap if necessary. Avoid use of commercial waxes or polishes or abrasive cleaning materials.

Instructions d'entretien:

Pour nettoyer, essuyez avec un linge humide et séchez à fond. Utilisez un savon doux au besoin. Évitez d'utiliser des cires ou produits à polir de type commercial ou des matériaux de nettoyage abrasifs.

Instrucciones para el cuidado:

Para limpiar, frótelos con algo húmedo y séquelos bien. Use un jabón suave si es necesario. Evite el uso de ceras o pulidores comerciales o materiales abrasivos.

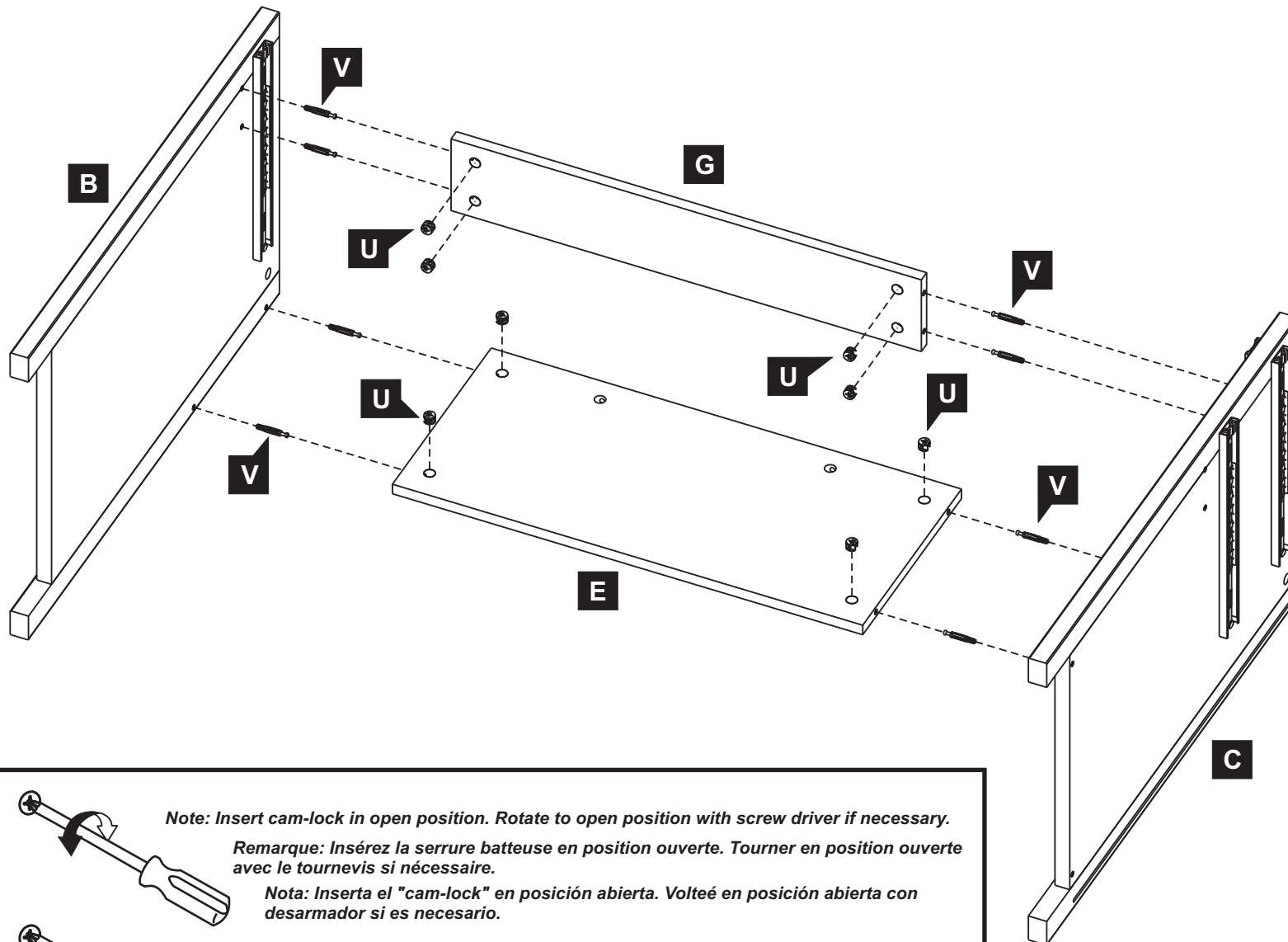
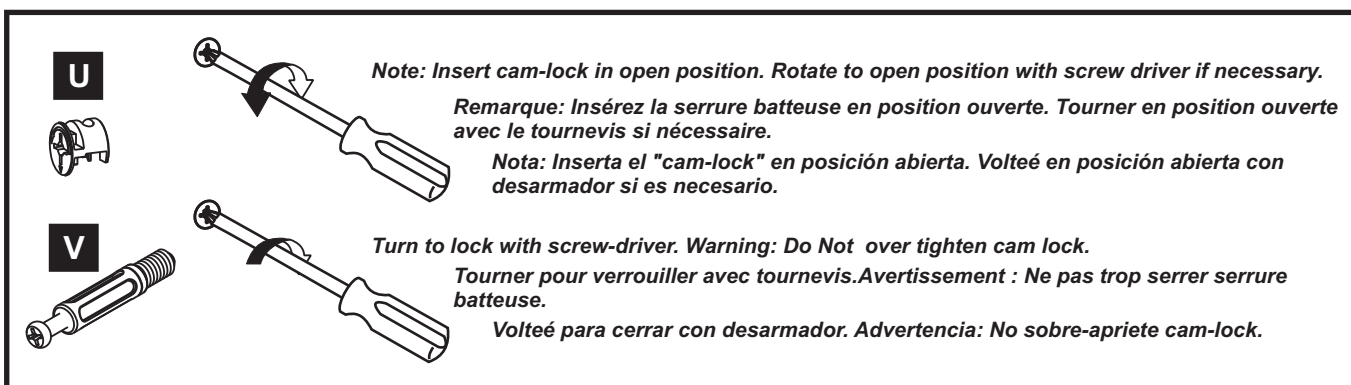
Assembly Instructions - Instructions d'assemblage - Instrucciones de ensamblaje
1

REF. 1

Assembly Instructions - Instructions d'assemblage - Instrucciones de ensamblaje

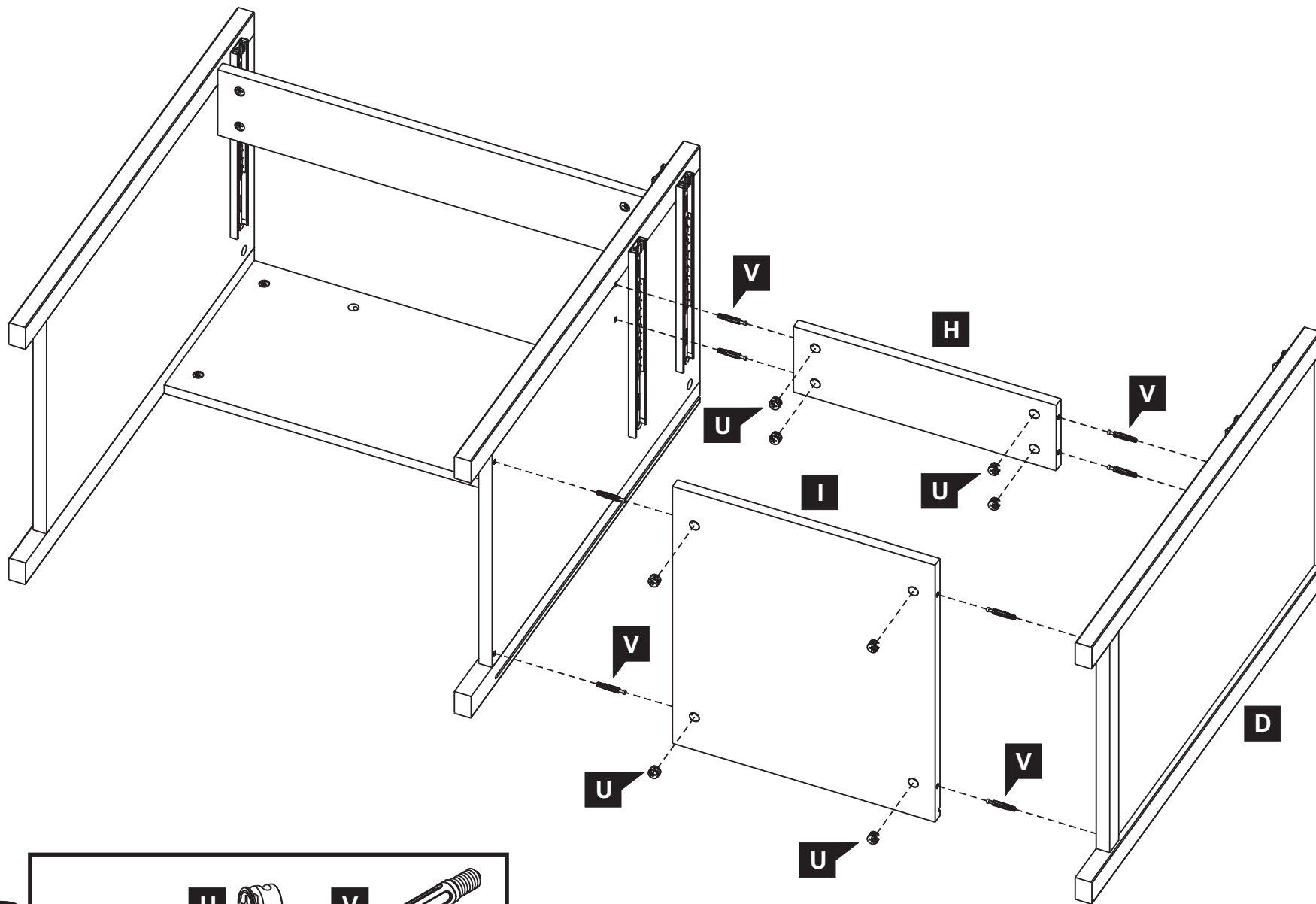
2



Assembly Instructions - Instructions d'assemblage - Instrucciones de ensamblaje

3

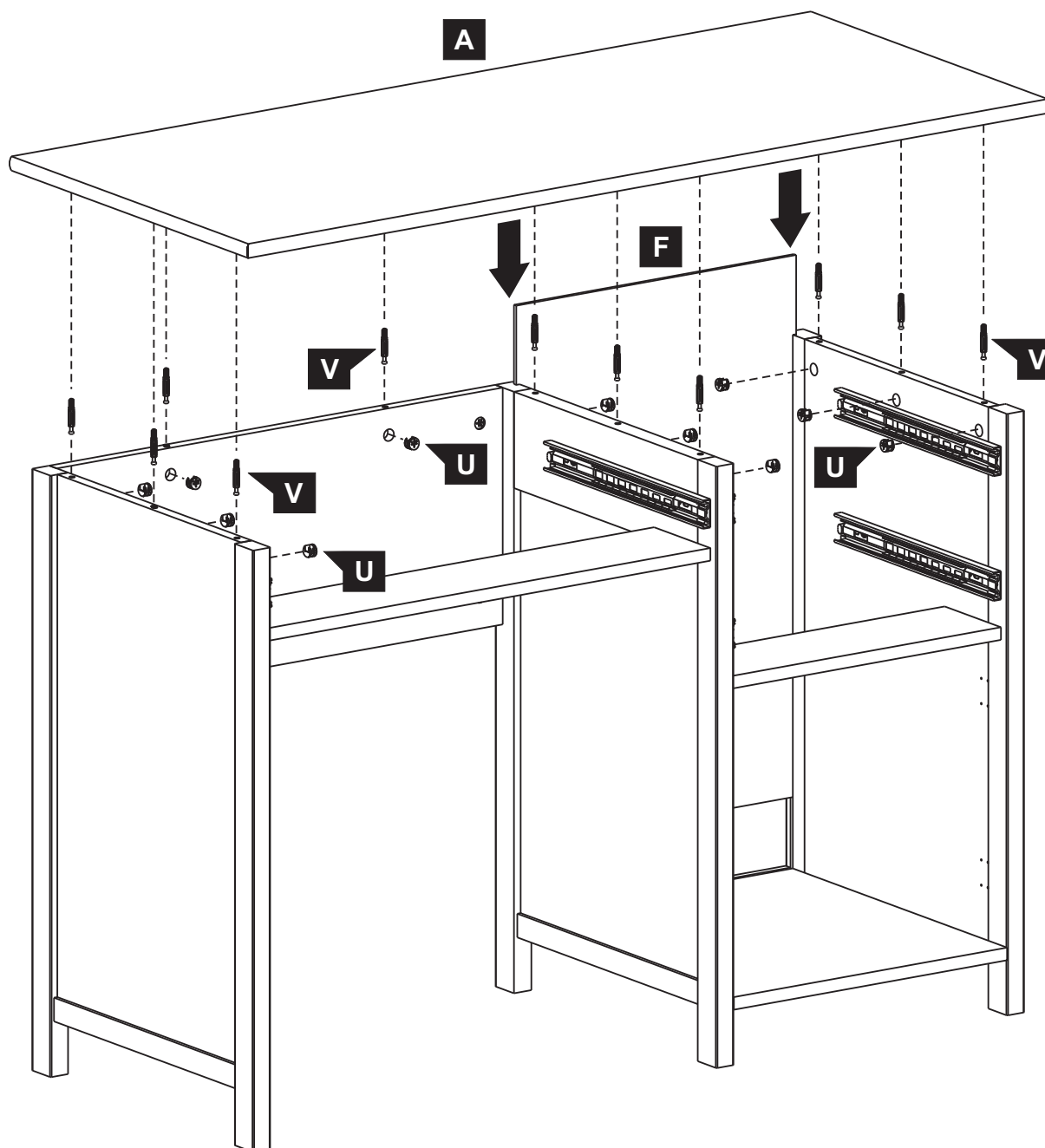

REF. 1

U 

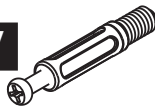
V 

Drawer - Tirior - Cajón

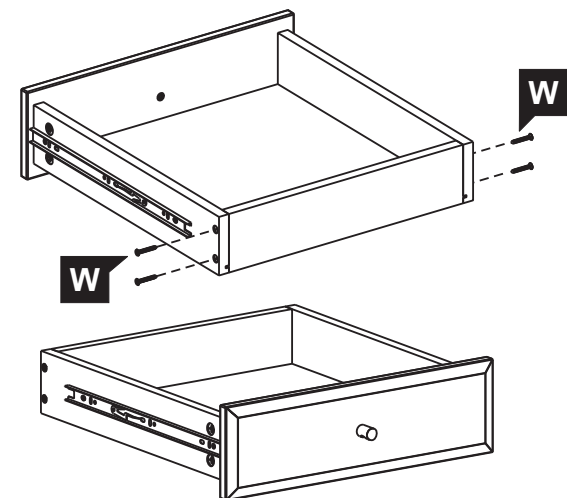
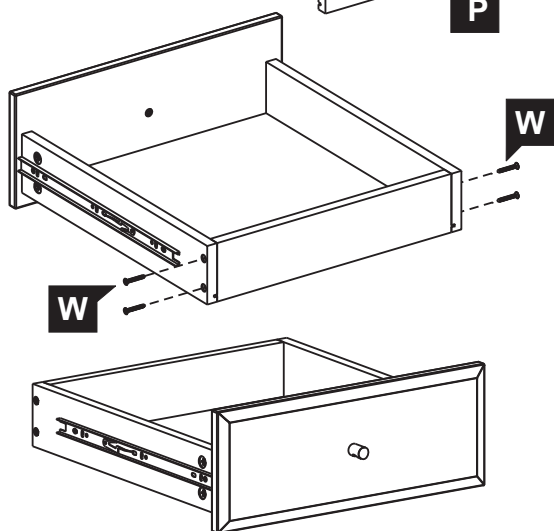
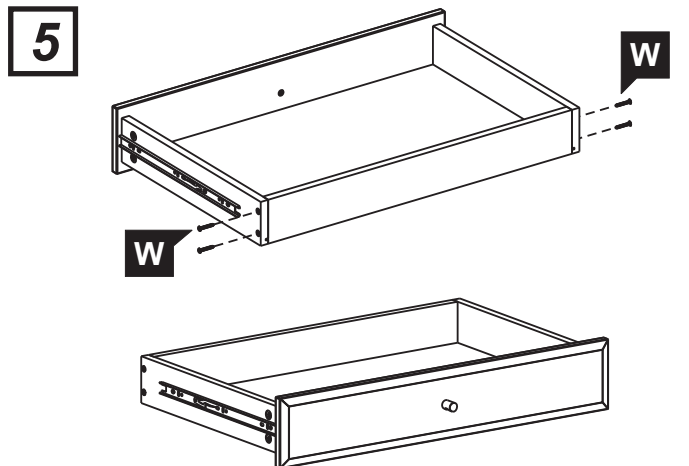
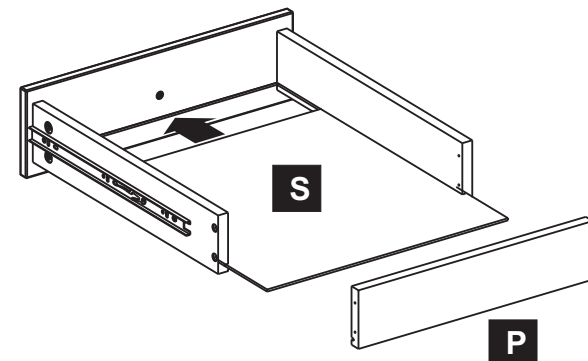
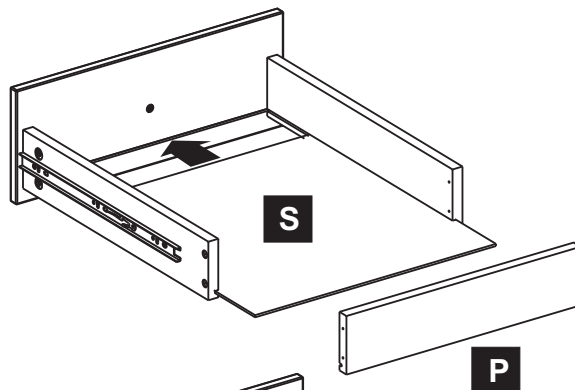
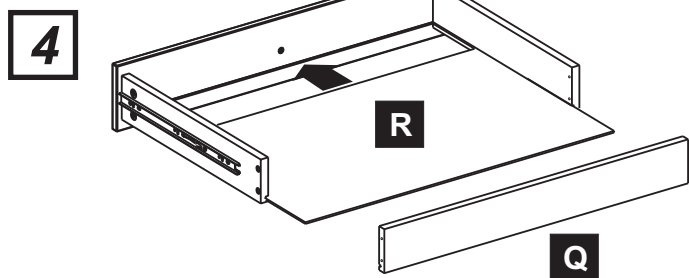
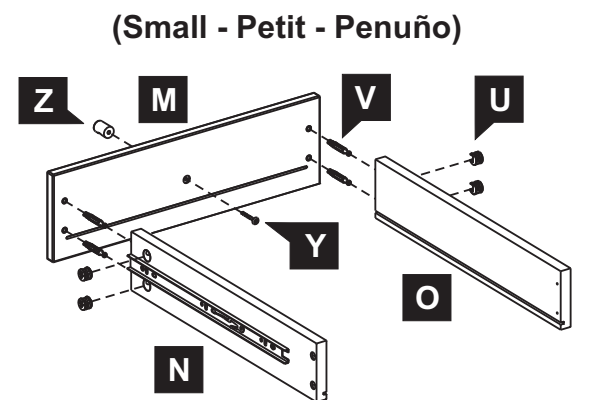
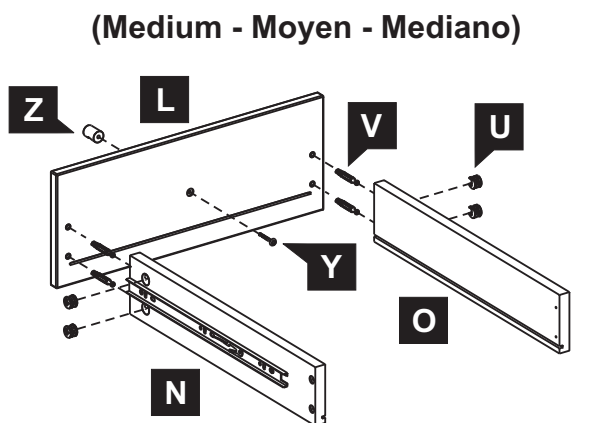
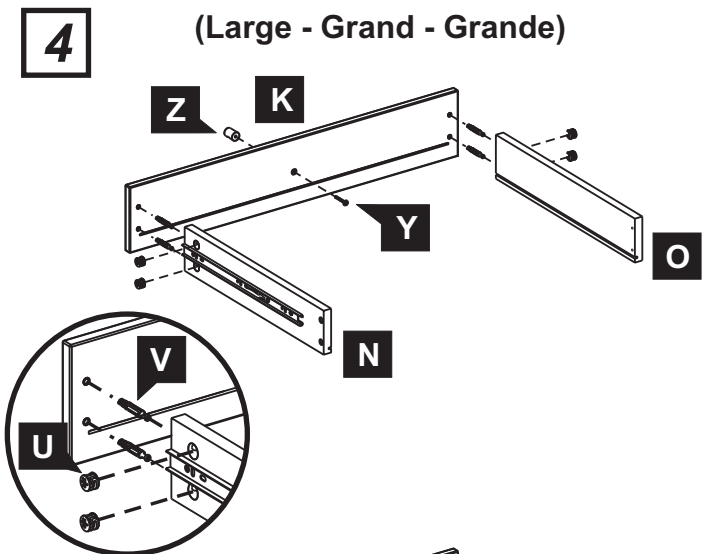

Assembly Instructions - Instructions d'assemblage - Instrucciones de ensamblaje

5

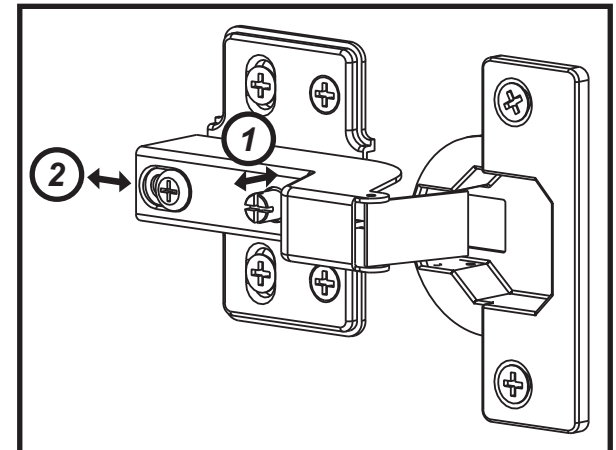
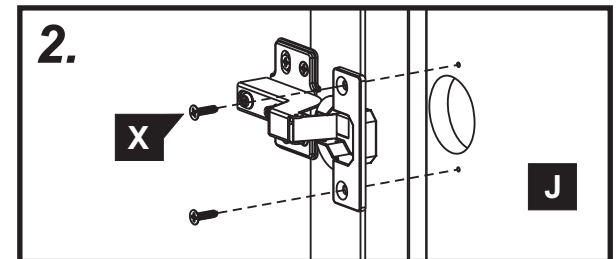
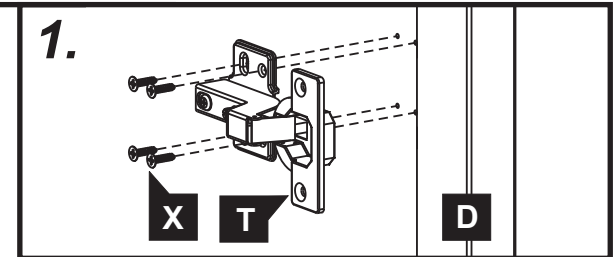
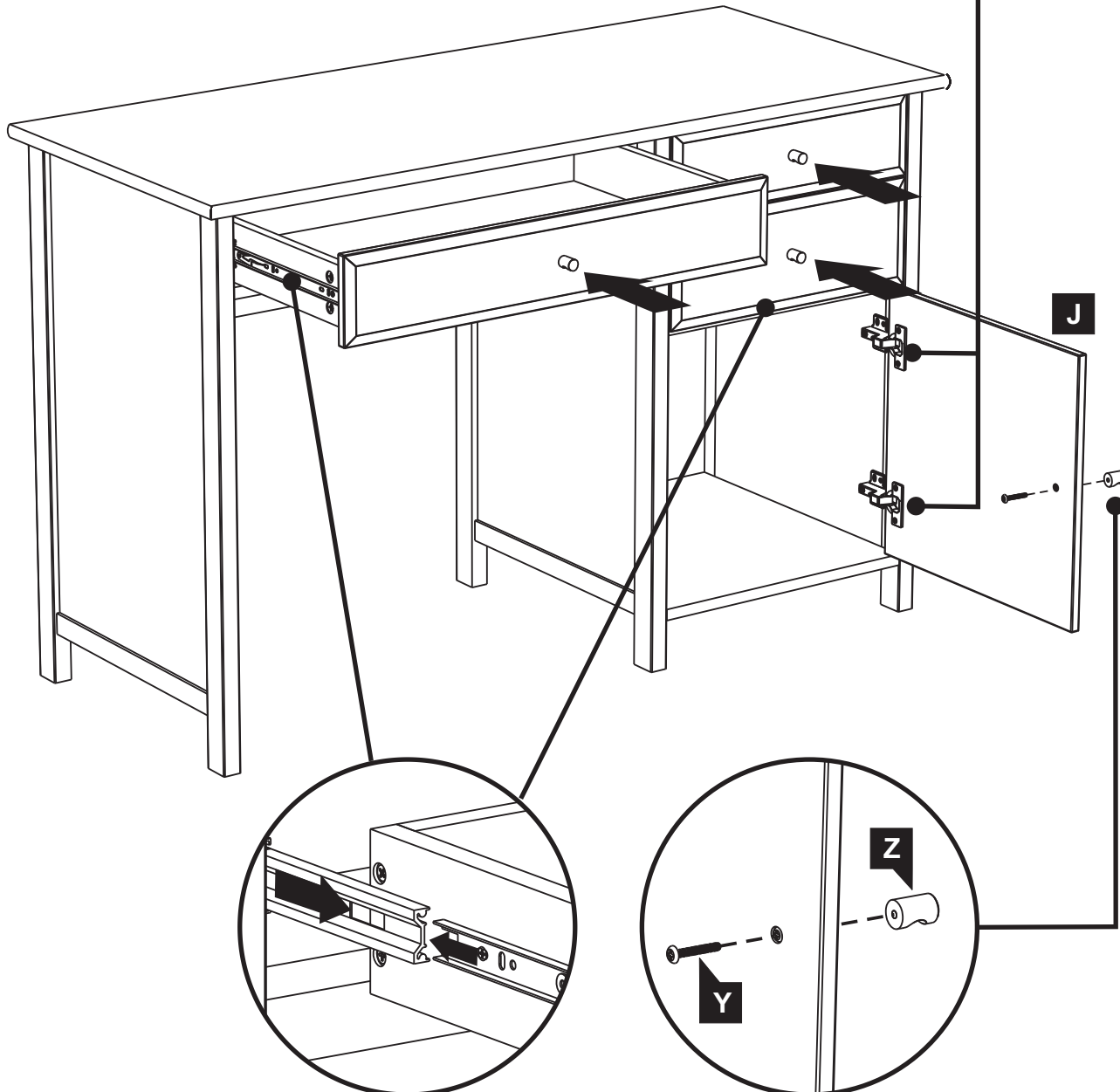

① To adjust door forward and back
 Pour ajuster la porte vers l'avant et vers l'arrière
 Para ajustar puerta al frente y para atrás

② To adjust door horizontally (side to side)
 Pour ajuster la porte horizontalement
 (d'un côté à l'autre)
 Para ajustar puerta horizontalmente
 (de lado a lado)