

User Manual

Disassembly Diagram

You'd better install it with a partner

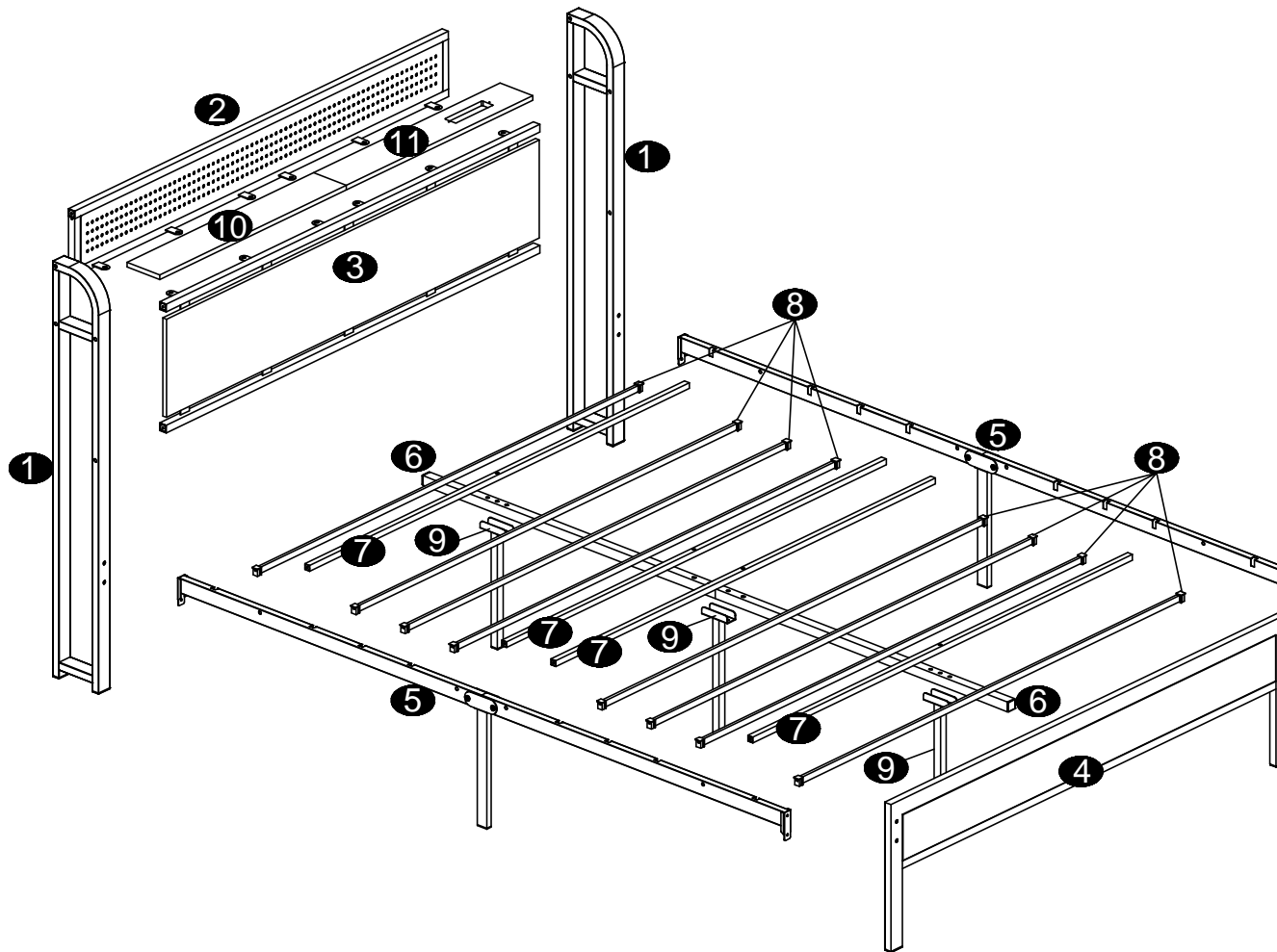

Before assembly, please read the USER MANUAL thoroughly for quick assembly, and check according to Accessories.

If you have any concerns or questions during installation or about product itself, please feel free to contact us Orders or Customer Support

Accessories

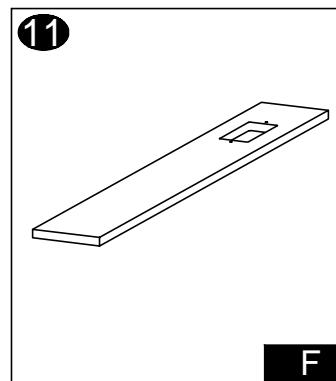
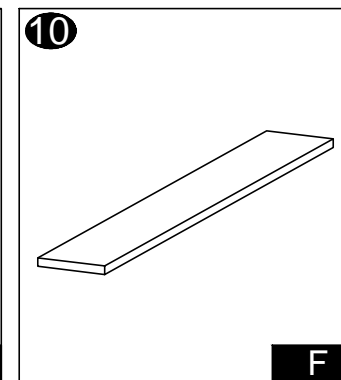
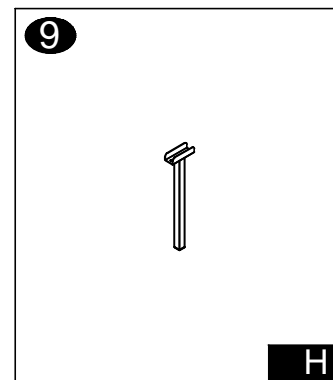
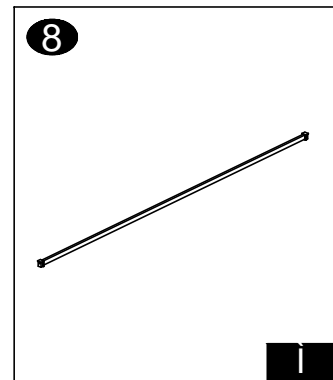
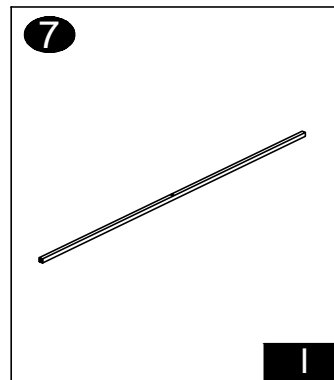
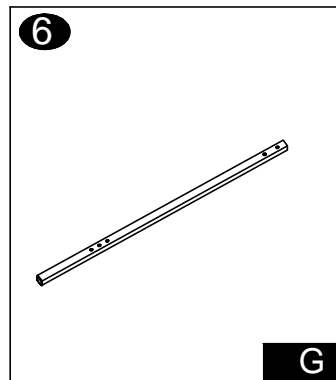
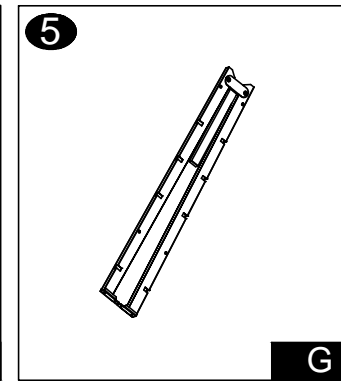
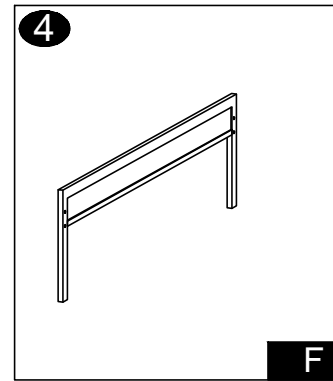
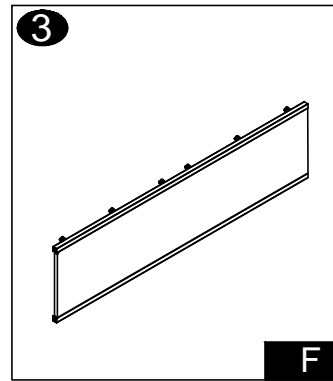
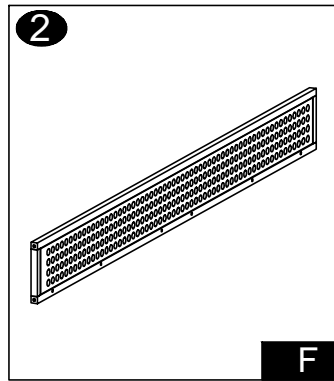
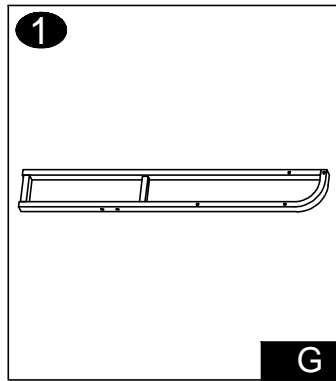

Accessories

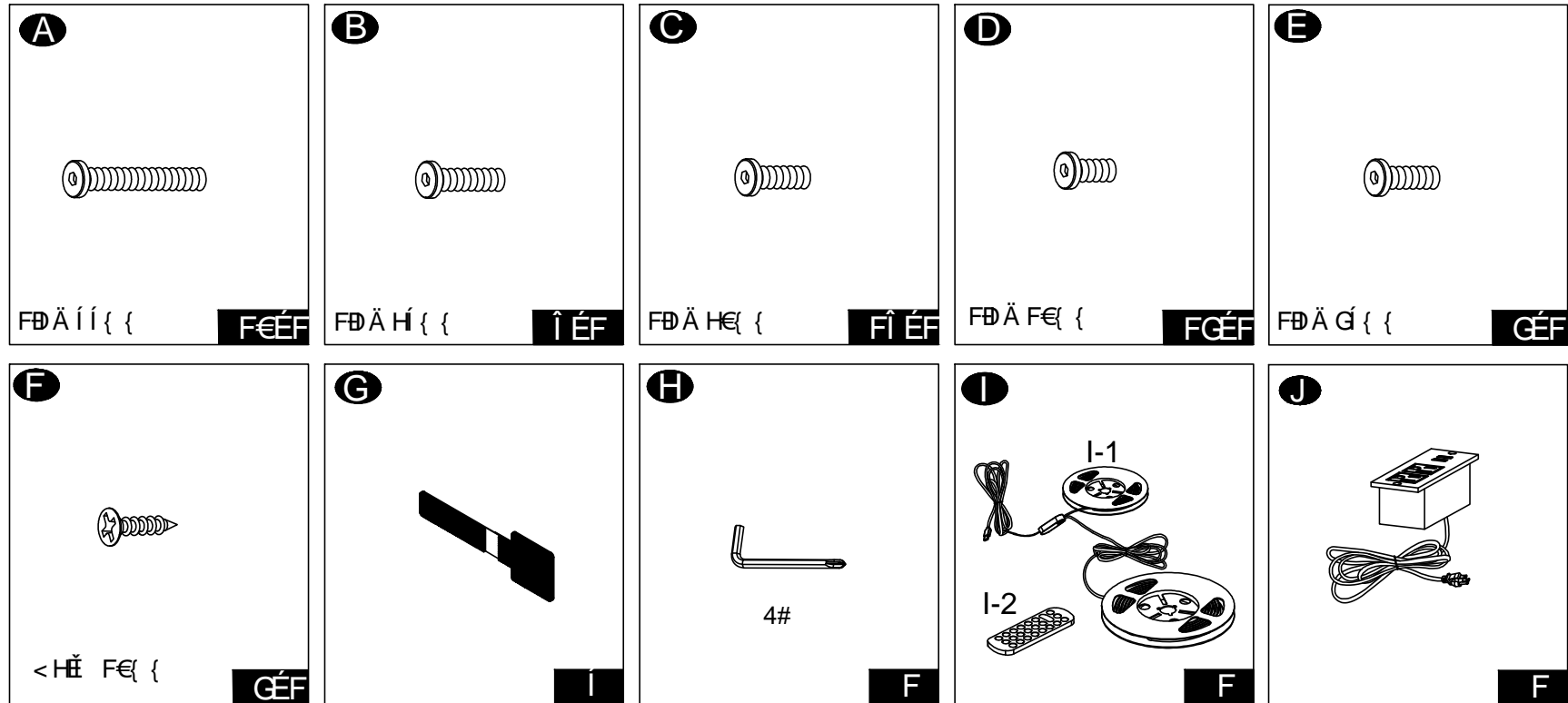

If the screws that we've provided does not match your bed frame

 step 1

Secure the metal mesh board **2** and board **3** between the frame **1** with screws **A**

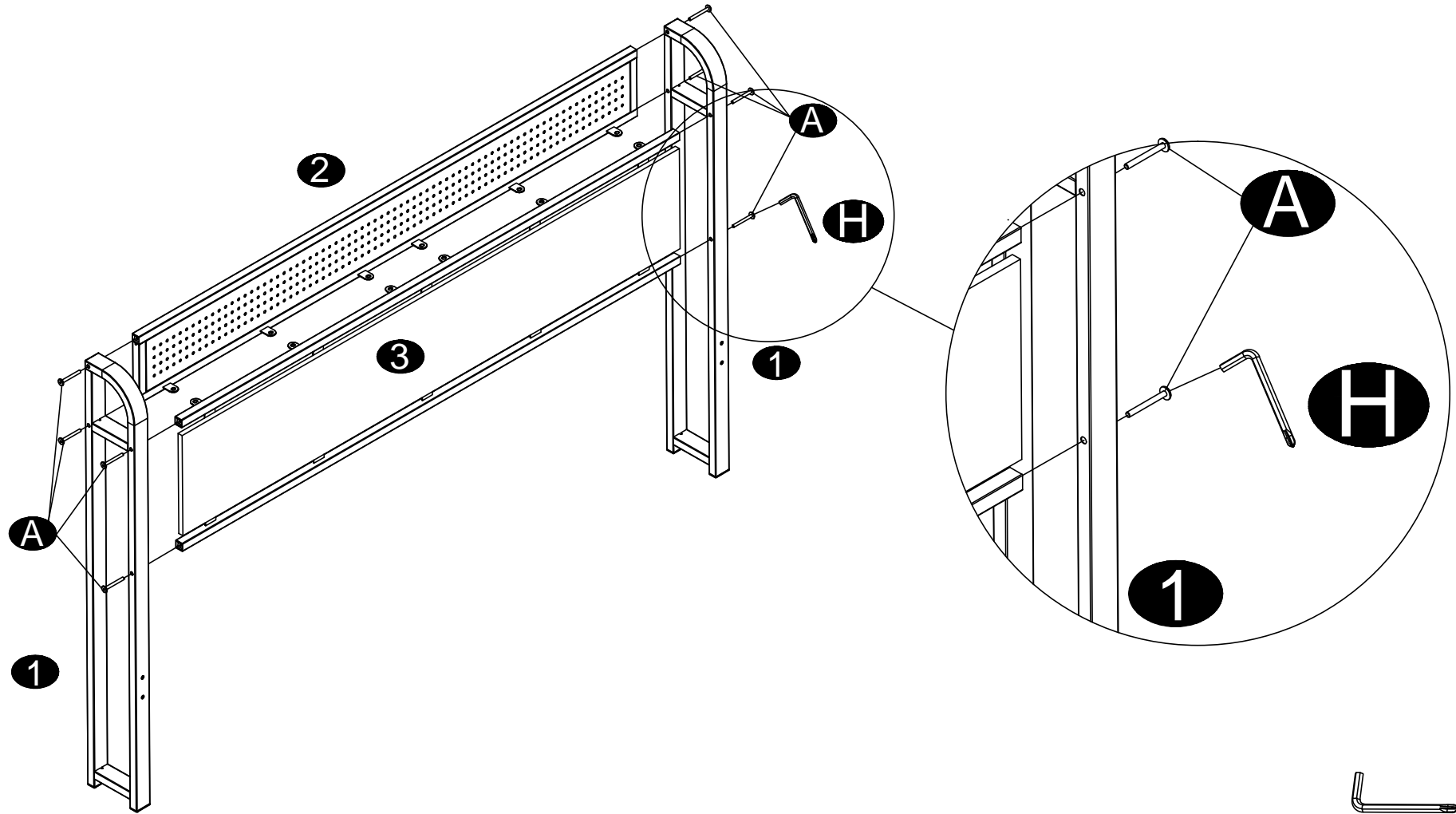

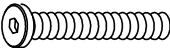
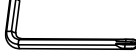
-  **A** x8pcs
-  **H** x1pc

 **step 2**

Fix the wood top board **10** & **11** on the metal frame **2** & **3** (from below) with screws **D**

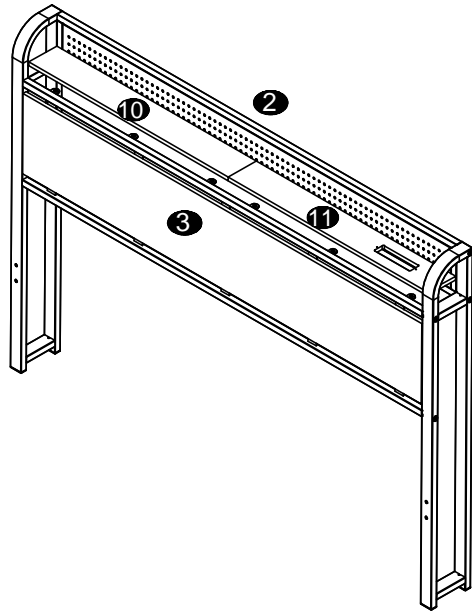

or

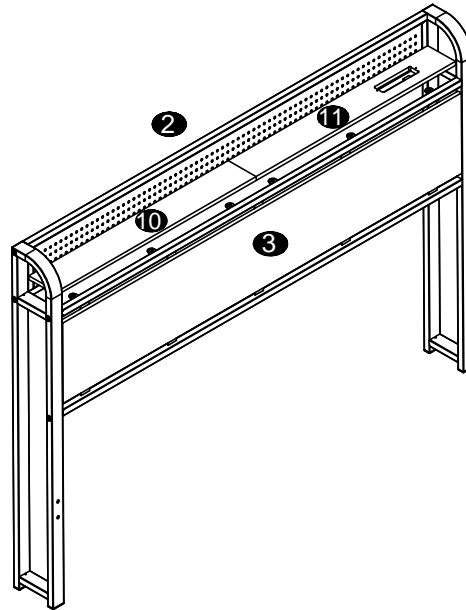

turn to the back side

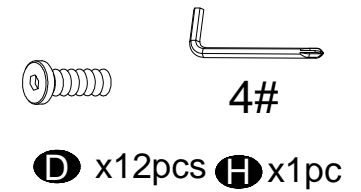
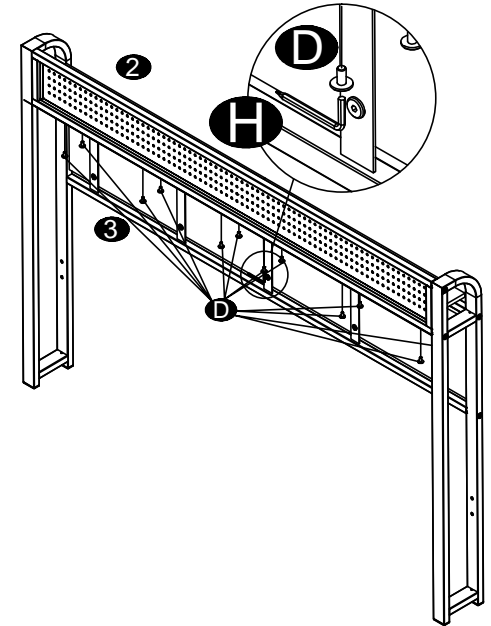

 step 3

Unfold the bed edge frame **5**

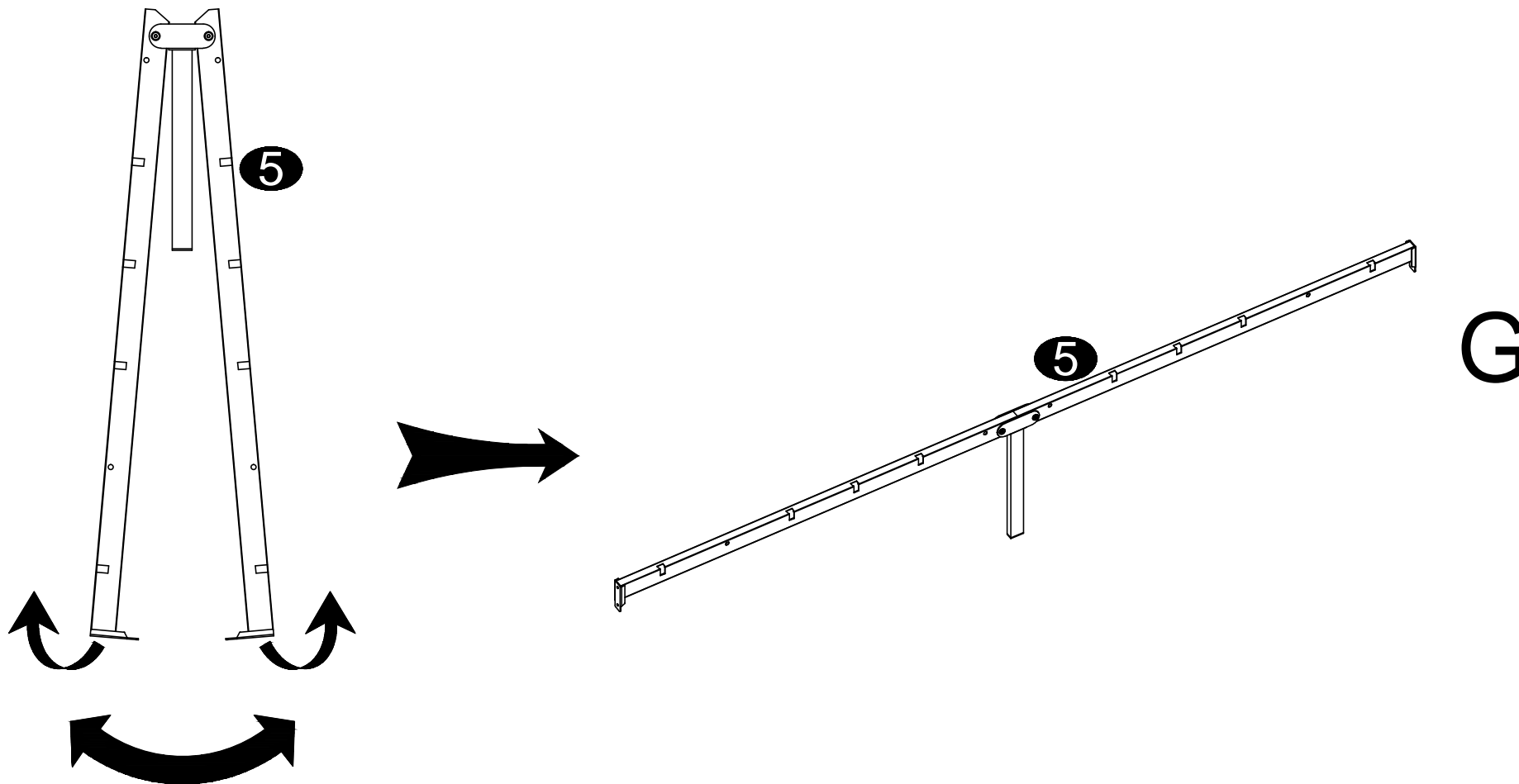



step 4

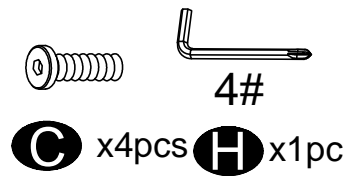
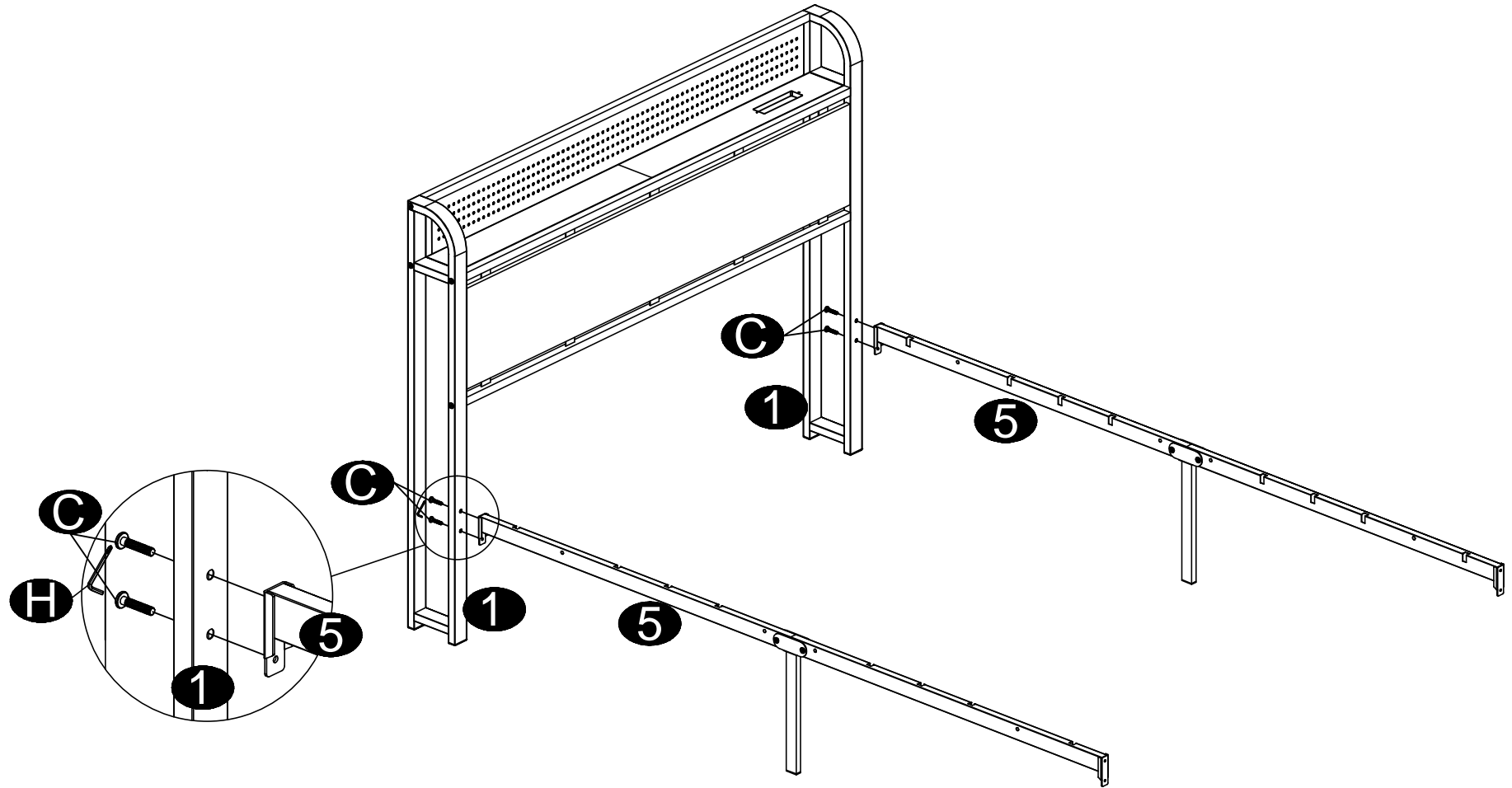

Fix the bed edge frame **5** on the bed frame with screws **C**

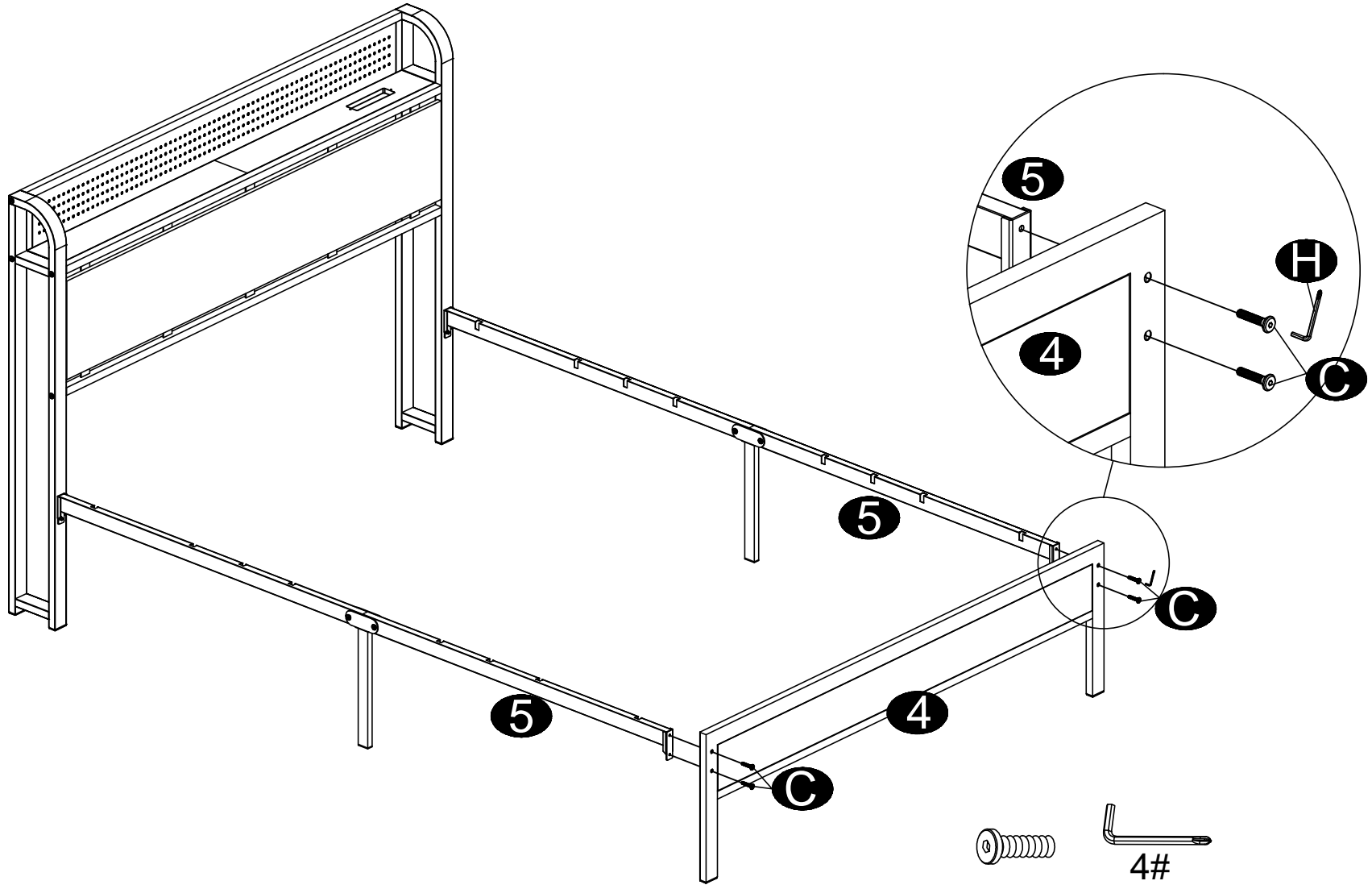

 step 5

Fix another side bed edge frame **5** on the footboard **4** with screws **C**



-  
- C** x4pcs **H** x1pc

 step 6

Lock the horizontal stick **7** with screws **C**

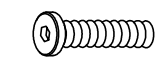
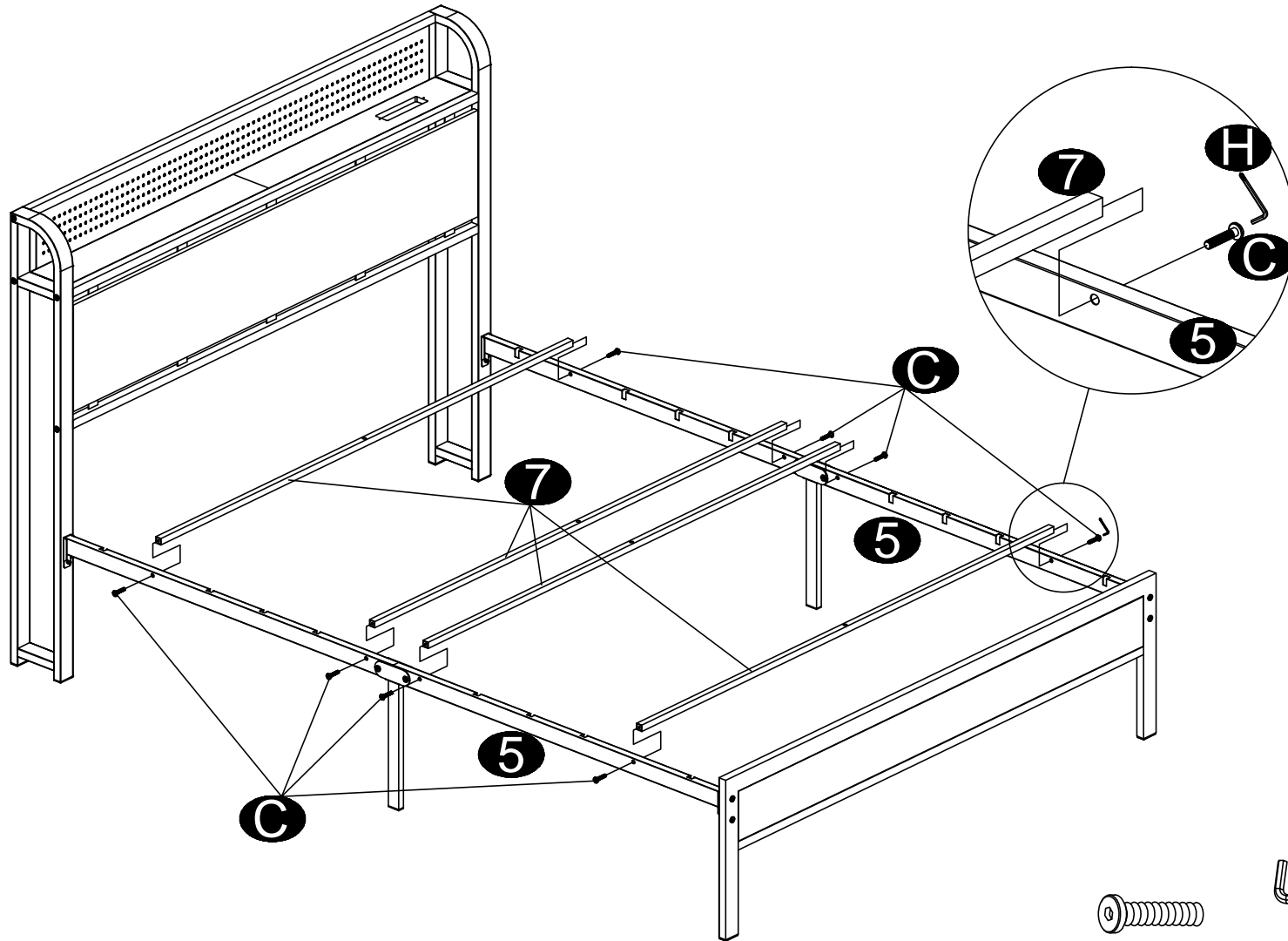

C x8pcs



4#

H x1pc

 step 7

Lock the horizontal stick **6** & **9** with screws **B**

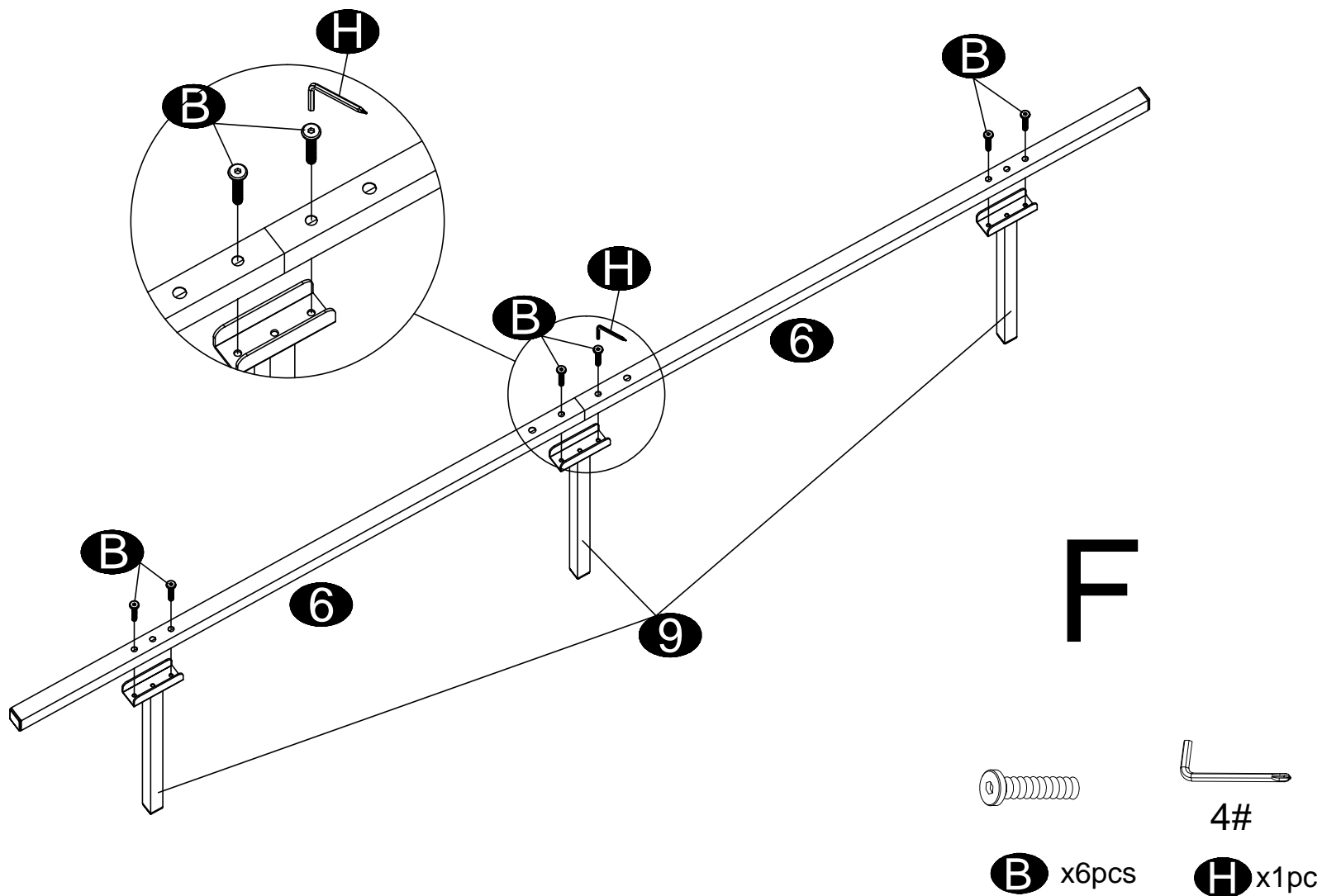



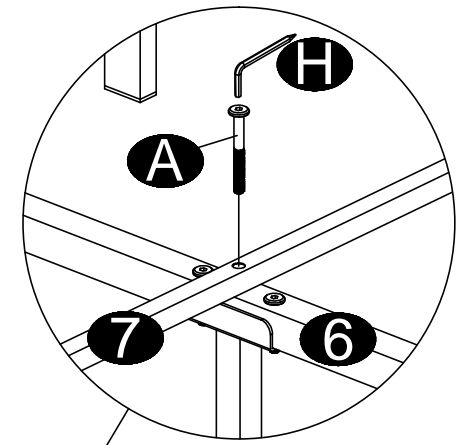
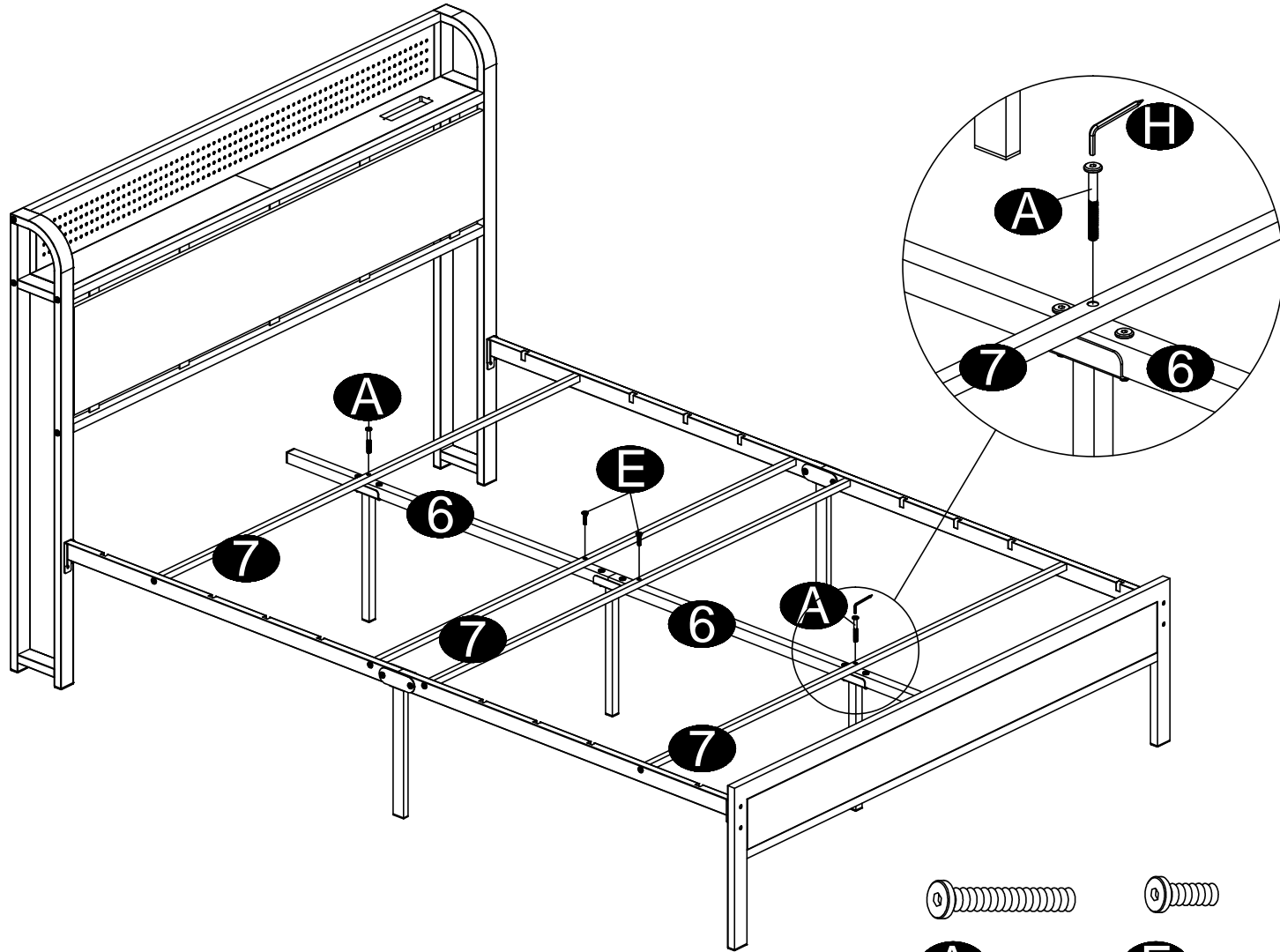

step 8

Fasten the metal stick to the metal frame with screws **A** and screws **E** (The holes as shown)

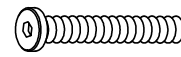

-  **A** x2pcs
-  **E** x2pcs
-  **H** x1pc

 step 9

Embed the metal stick **8**. Insert parts **8** into the bed frame.

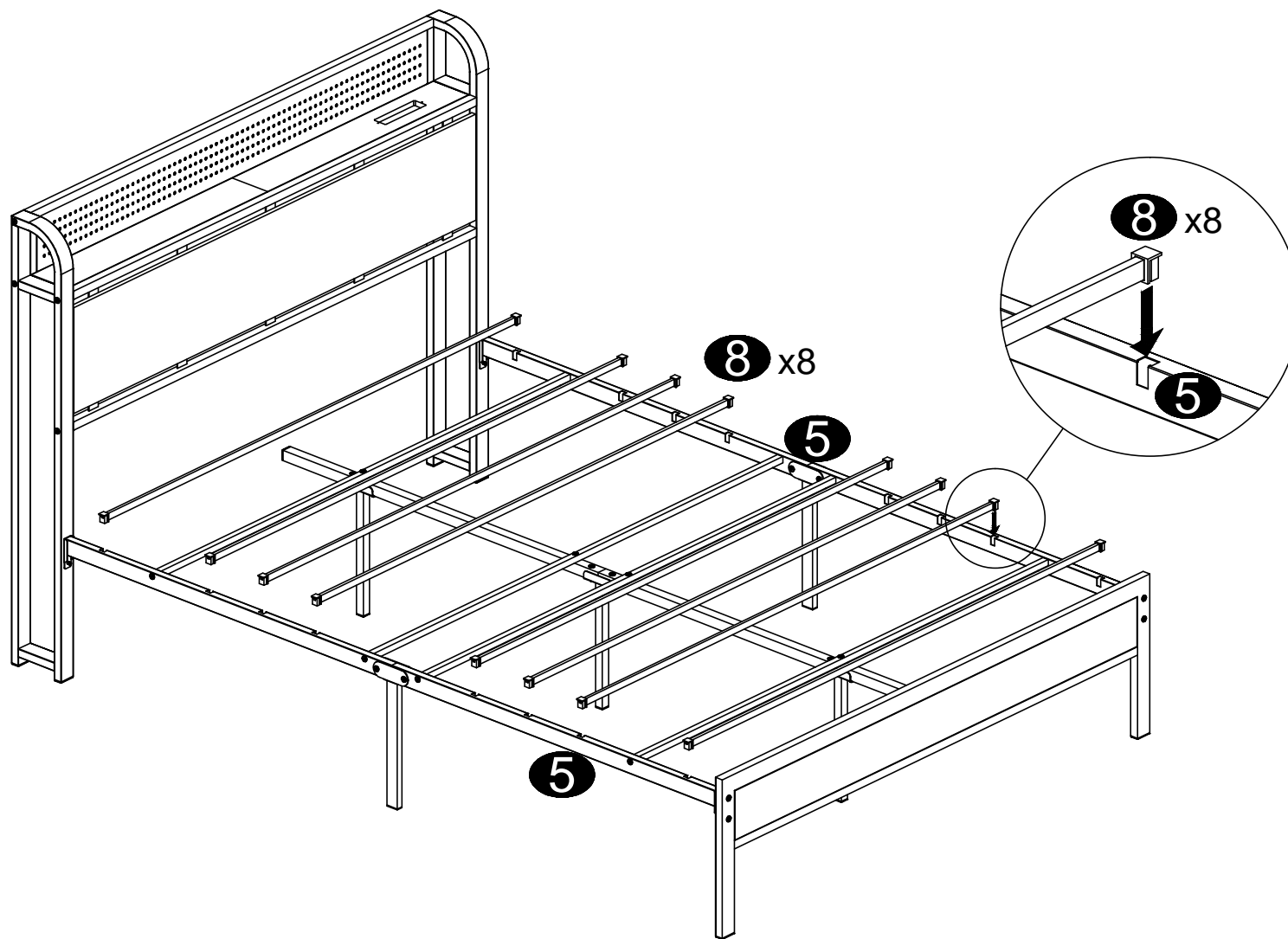



step 10

Install the charging station **J** with the screws **F**

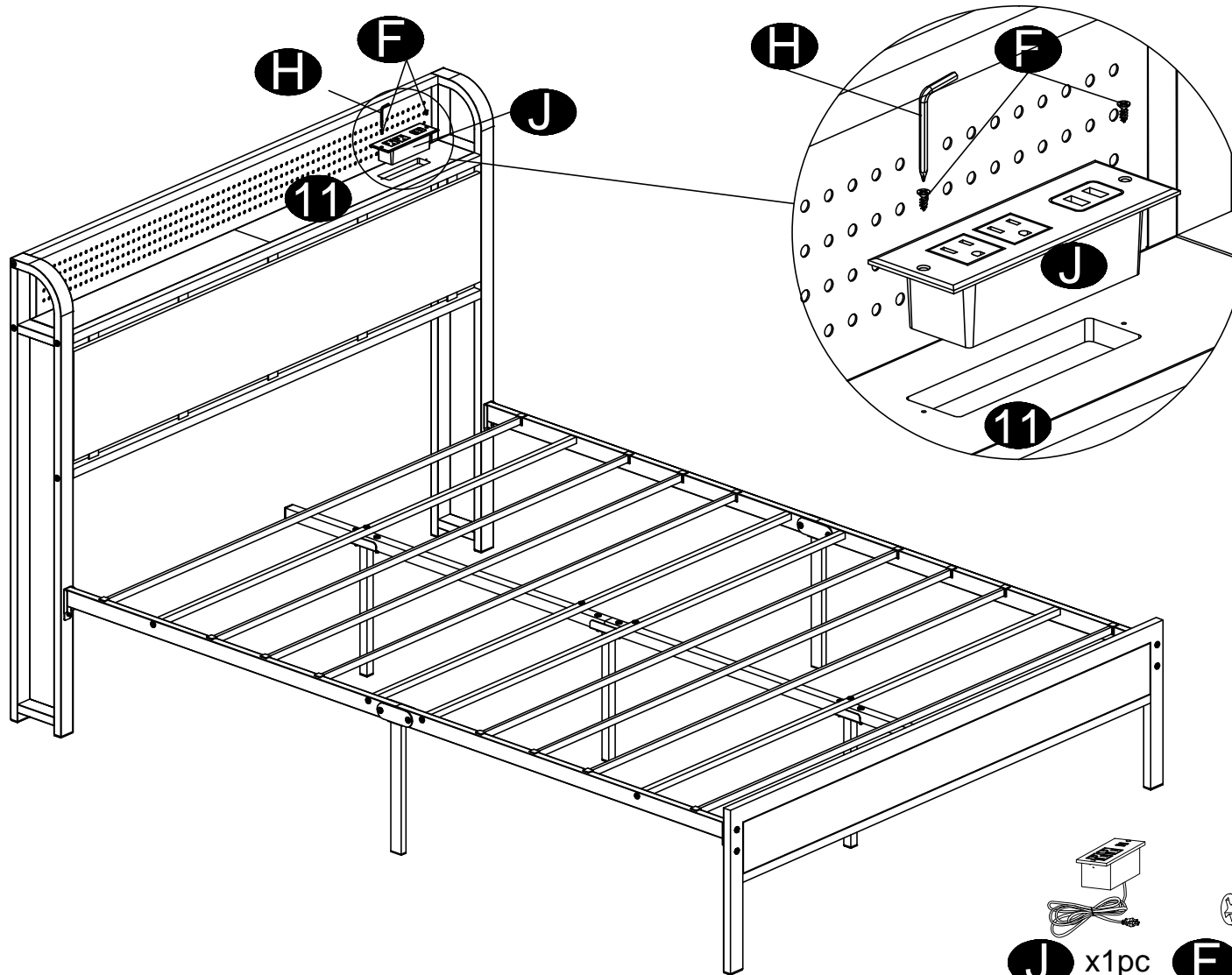

- J** x1pc
 - F** x2pcs
 - H** x1pc
- 4#

 step 11

Install the light strip in the back headboard and footboard of the bed frame.
(In the position shown in the arrow)

11-2

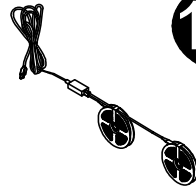
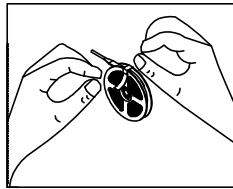

11-1

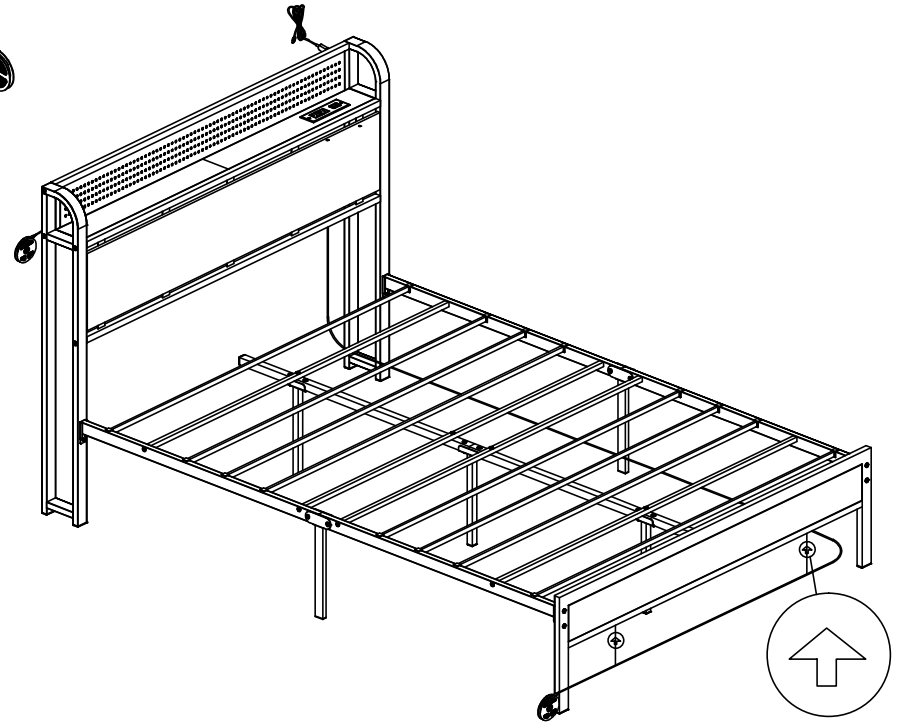
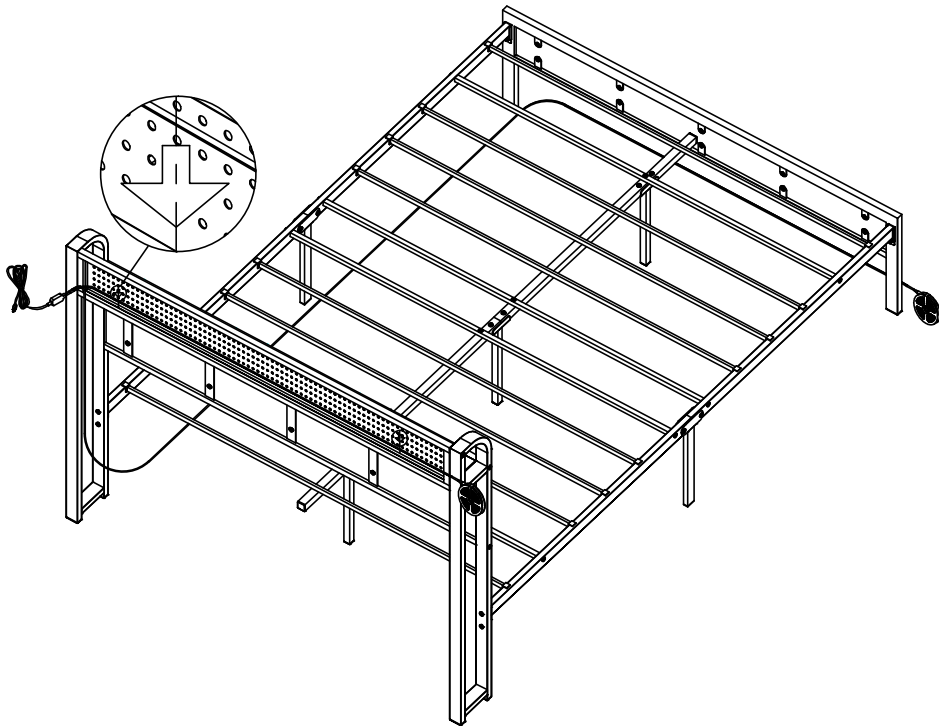

I x1pcs

 step 12

You could tidy up the wire using part G(12-1/2/3)

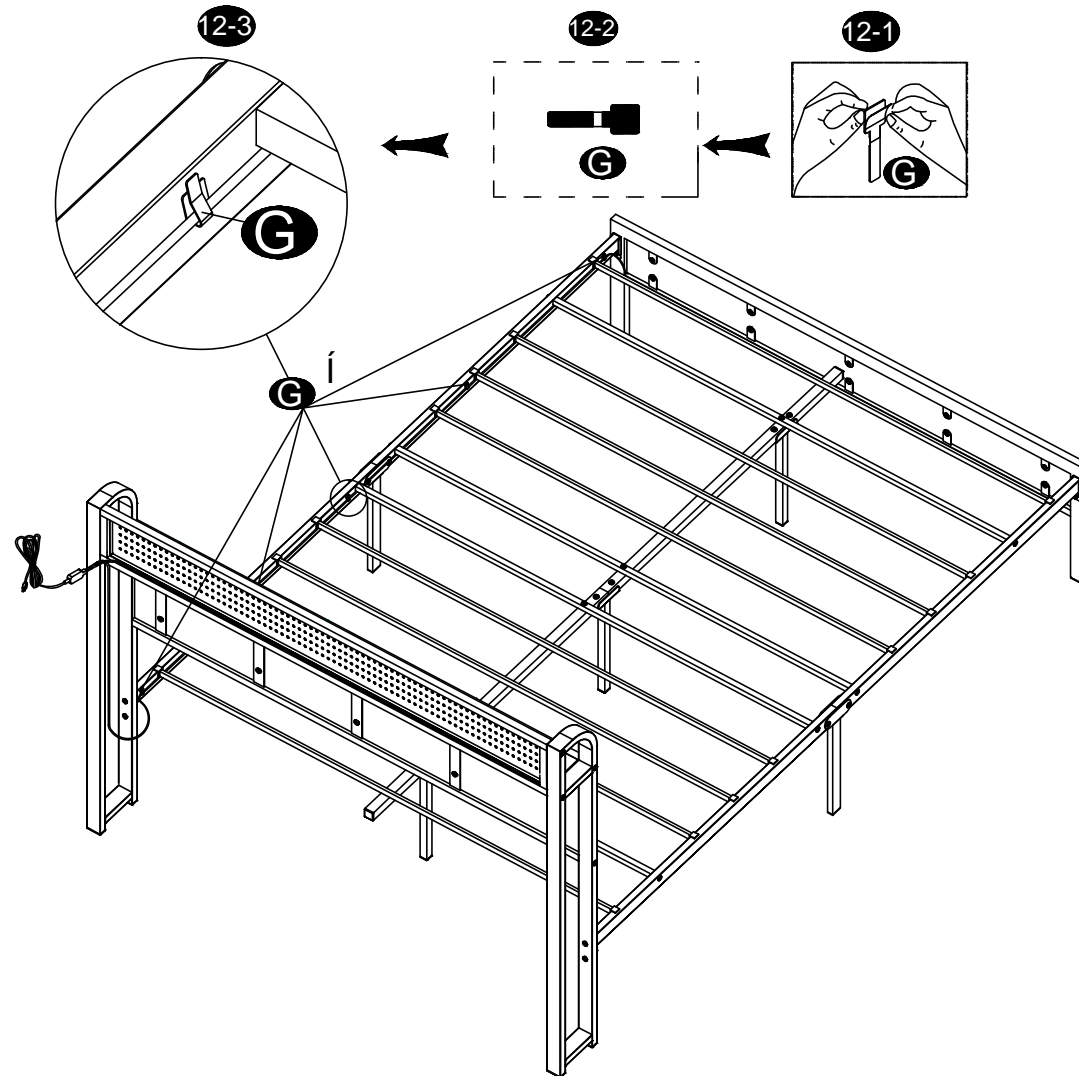

 step 13

Remote Control

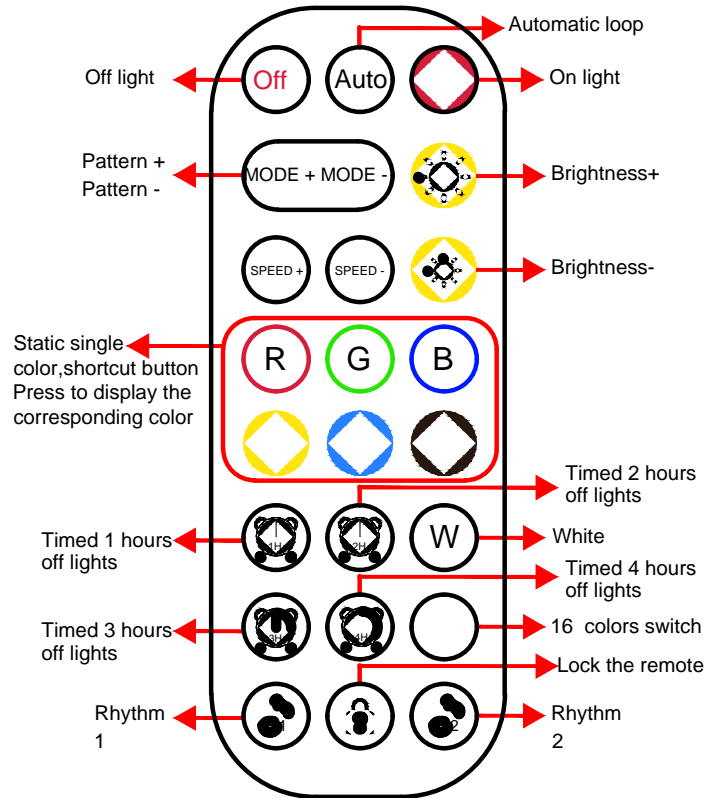

You can dim the light with the remote control or scan the QR code to download APP

Customers prepare their own batteries

 step 14

Completed

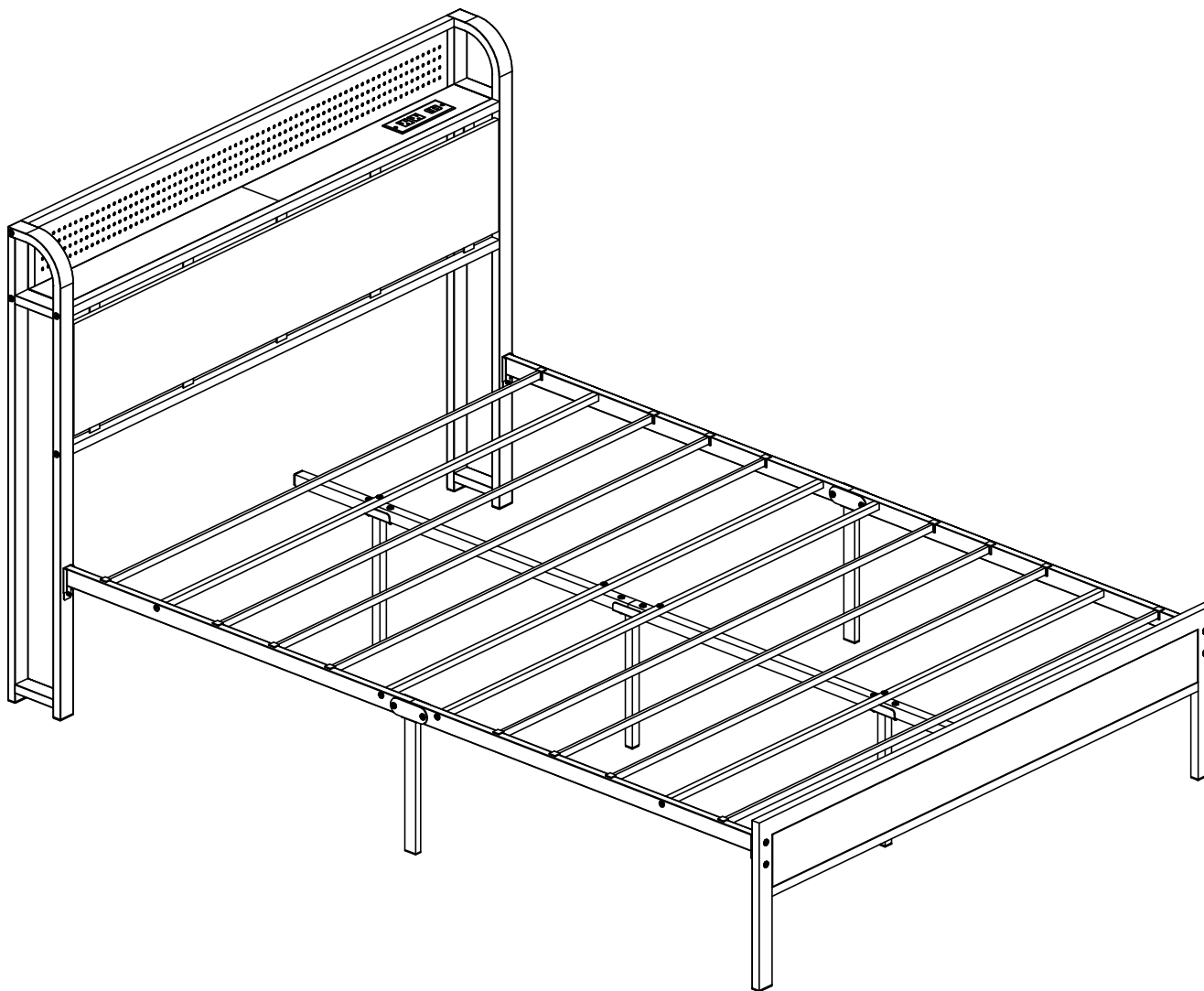

Customer Service

1-Year Warranty

We guarantee your product is free from defects in product material and workmanship for one(1)year starting from the date of purchase during normal use of household conditions. If your appliance fails within the limited warranty period, we will arrange a new replacement free of charge, and cover all the shipping costs.

Quick Response within 24 Hours

If you are still unable to resolve the issue you are experiencing, please contact us immediately at our support. It doesn't matter if the product has been installed, our customer support team will respond within 24 hours and assist you quickly and efficiently. The most efficient way to confirm your problem with us is to attach a video or picture illustrating your product issue.

Problems You May Encounter

PART	PROBLEM	SOLUTION
Whole Product	Parts are missing, defective or having wrong parts in package.	You can contact us and we will get back to you within 24 hours.
	Encountering non-human caused damage during usage.	If the product is damaged due to non-human causes, please keep the product and send us photos of it. We will ascertain the cause of the product damage within 48 hours and provide you with a satisfactory solution.
Board Surface	Board Surface is broken, scratched or lack of some screw holes.	You can contact us and we will get back to you within 24 hours.
	The screw holes that on the board and steel frame don't line up.	1. Please tighten the screws on the board by 70%, do not tighten completely. 2. Adjusting board and steel frame until the screw holes are lined up,then tighten all the screws.
	The wood board is uneven or not tight that has gaps after being assembled.	You can contact us and we will get back to you within 24 hours.
Steel Frame	The steel frame is bent, broken, painted, rusted or damaged.	You can contact us and we will get back to you within 24 hours.
	The bed frame is unstable after being assembled.	1.Check if the screws are tightened. 2. Read through out the manual, check are there any parts installed incorrectly or missing assembled. 3. If your problem still can't be solved, please feel free to contact us.

If you can't finish the installation, please feel free to contact us