

# Assembly Instructions

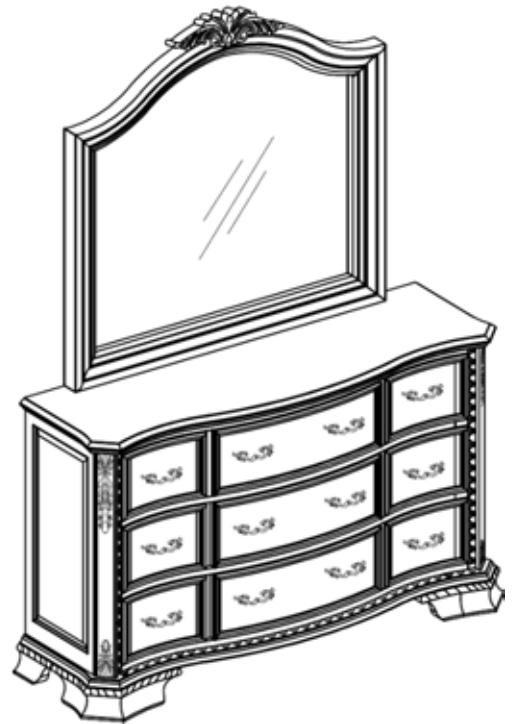
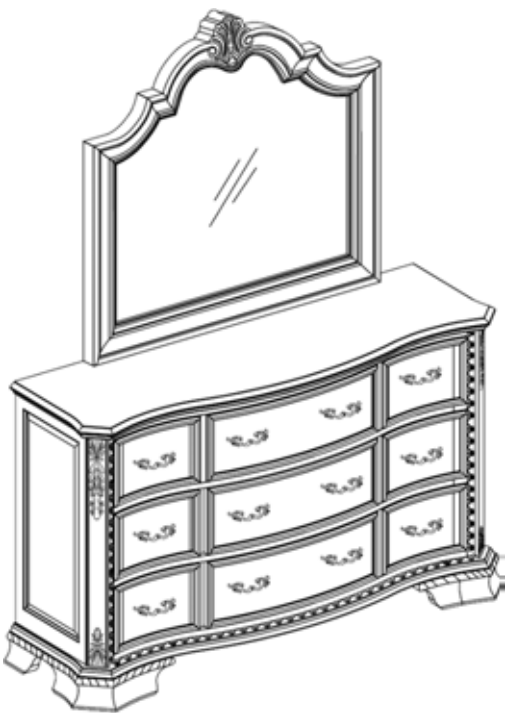

DRESSER AND MIRRORS ARE SOLD AND PACKED SEPARATELY

## ASSEMBLY RATING

The Assembly Rating is a 5-point system that shows the degree of effort needed in assembling a specific product (with 1 being easy and 5 being difficult). For some products, two persons are recommended.

EASY  DIFFICULT

## Tools Required for Assembly:

Allen Wrench



(Included)



2 PERSONS RECOMMENDED

# ASSEMBLY & CARE ADVICE

FOR YOUR FURNITURE TO LAST, CORRECT ASSEMBLY AND PROPER MAINTENANCE ARE NECESSARY. PLEASE FOLLOW THE INFORMATION PROVIDED BELOW TO FULLY ENJOY YOUR FURNITURE.

## BASIC ASSEMBLY TECHNIQUES

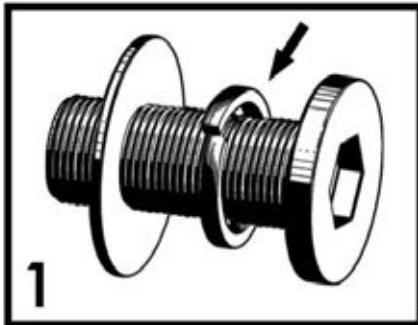

1  
When lock or spring washer is used in an assembly, please make sure the lock or spring washer is placed between the larger flat washer and the head of the screw or bolt.



2  
Position each part correctly and insert screws or bolts into their respective holes by hand tighten or using the proper hand tool. Only tighten when step is completed or when instructed to do so.



3  
Use cardboard or carpet area when assembling furniture to prevent scratches. Make sure the furniture rests on a flat and level surface with each leg evenly touching the floor.

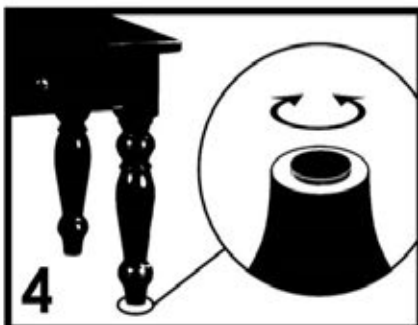

4  
Some furniture comes with height adjustment knobs underneath each leg. To lower or to raise each leg, you need to turn clockwise or counterclockwise, respectively.

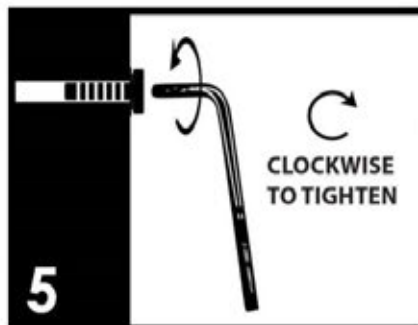

5  
Make sure all parts are properly aligned, then use the appropriate hand tool to completely tighten the bolts or screws. Do not use power tools and do not overtighten.

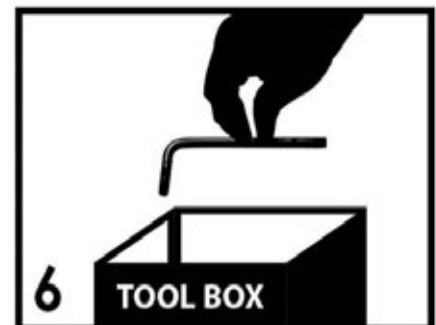

6  
Save the instructions and store the Allen wrench or any supplied tool for later maintenance. After two weeks, check and tighten any loose hardware and repeat again every six months thereafter.

IT IS THE USER'S RESPONSIBILITY TO MAINTAIN THE FURNITURE. THE HARDWARE MAY LOOSEN OVER TIME AND MAY CAUSE THE FURNITURE TO BE WOBBLY AND UNABLE TO SUPPORT ITS INTENDED WEIGHT CAPACITY. THIS MAY LEAD TO COLLAPSE AND MAY CAUSE SERIOUS INJURY.



FAILURE TO FOLLOW THE GUIDELINES ABOVE MAY RESULT IN INJURY AND/OR PROPERTY DAMAGE.



Before you begin, please read Page 2 of "Assembly and Care Advice".

And remember, do not tighten until each step is completed or instructed.

MD

### Parts List

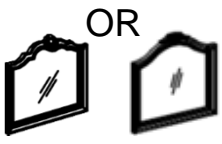

#1 x 1 pc  
7296 or 7267 Mirror



#2 x 1 pc  
Dresser



#3 x 2 pcs  
Mirror Support Bracket

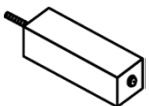

#4 x 1 pc  
Center Leg

### Hardware List



#A x 8 pcs  
Bolt 1/4"x1-1/2"



#B x 8 pcs  
Flat Washer



#C x 1 pc  
Allen Wrench



Due to the size and/or weight of this product, it is highly recommended that the assembly should be done near the area of its intended location. Make sure you have enough space to move around during the assembly. ALWAYS have at least two people to help with transporting and assembling the product to avoid any potential injury and/or damage, especially with the fragile nature of the mirror.



With the help of another person, carefully place the dresser (#2) on its back on a protected surface. Align the threaded end of the center leg (#4) with the pre-drilled hole on the bottom center of the dresser (#2) and tighten by hand until secured.

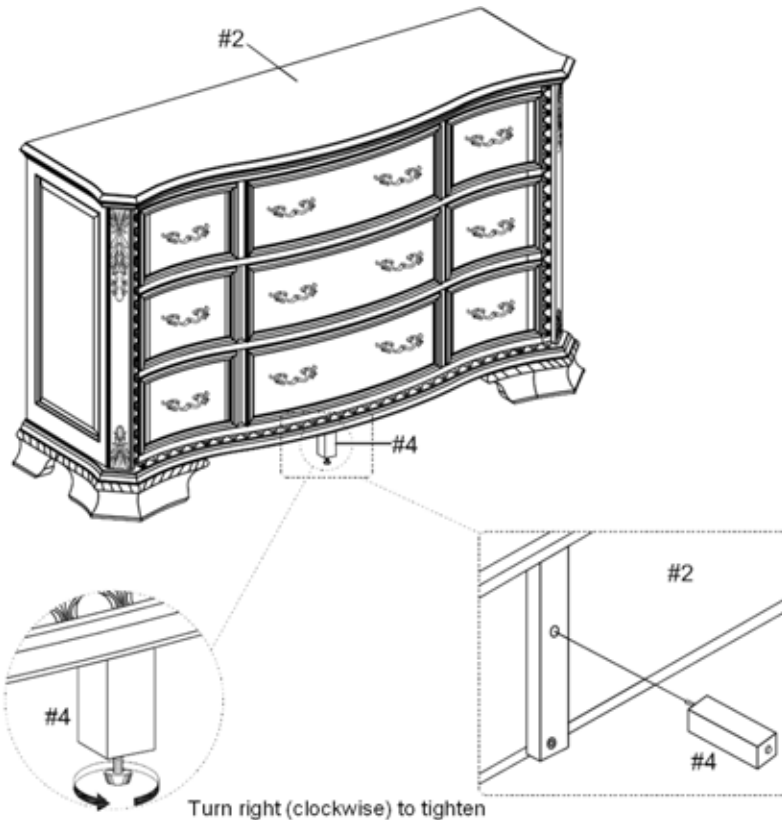

Adjust the leveler according to the ground level. To lower or to raise the center leg (#4), you need to turn the leveler clockwise or counterclockwise, respectively.



Depending on what set was purchased, the assembly of mirror or the 7267M mirror onto the will be the same.

#A x 8 pcs  
#B x 8 pcs

- I. The two mirror support brackets (#3) are already attached behind the dresser (#2). Position the mirror support brackets (#3) vertically to align with the pre-drilled holes of the dresser (#2) AND the mirror (#1).
- II. Prepare 6 bolt assemblies by inserting the flat washer (#B) onto the bolt (#A). (The other 2 bolt assemblies are already attached from the factory.)
- III. Insert those bolt assemblies onto the mirror support brackets (#3) and secure those bolts using an Allen wrench (#C) to lock the mirror support brackets (#3) with the dresser (#2) AND the mirror (#1).
- IV. Tighten all bolts, including those that were already attached from the factory.

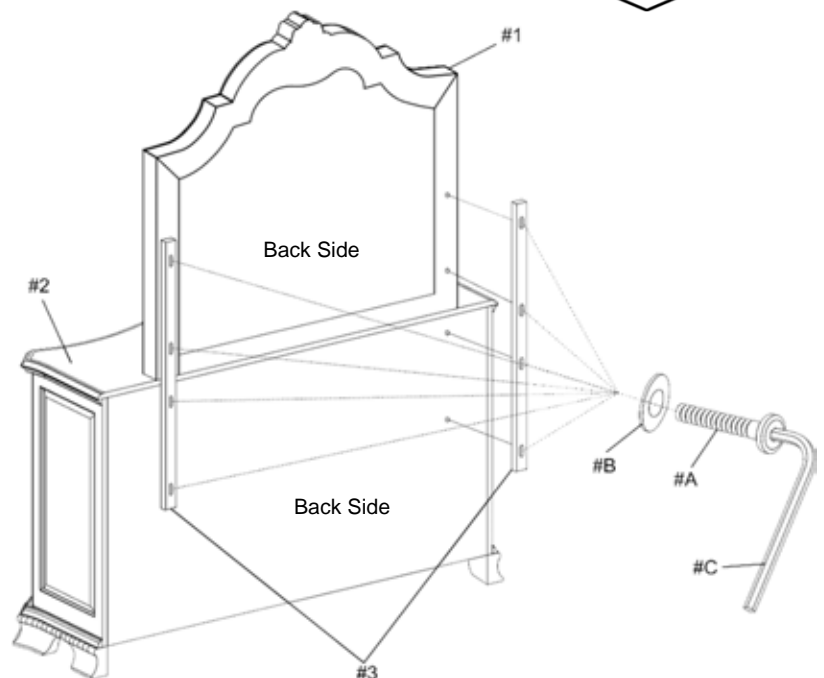

**ASSEMBLY IS COMPLETED**