

Assembly Instructions

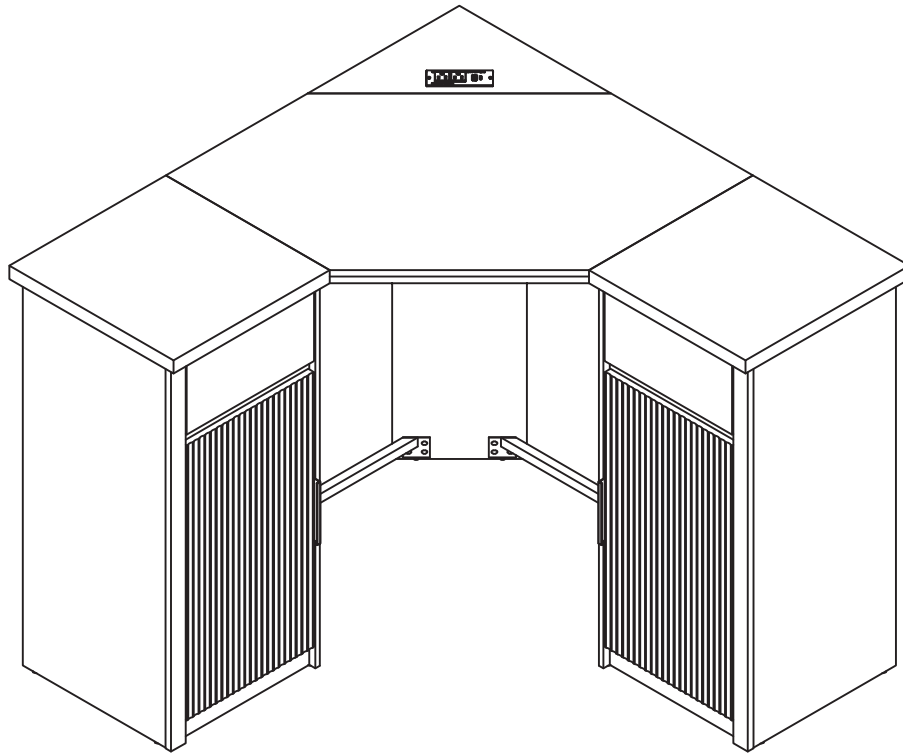



All necessary tools for assembly are included
but for faster assembly, a power drill is recommended



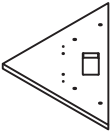
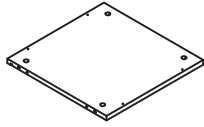
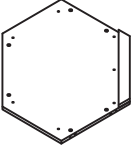
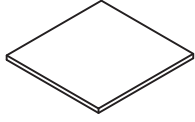
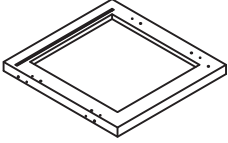
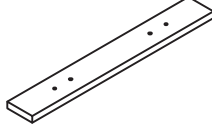
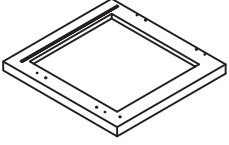
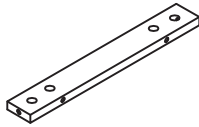
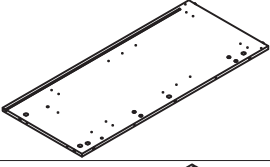
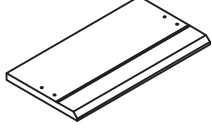
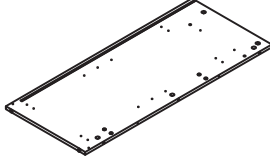
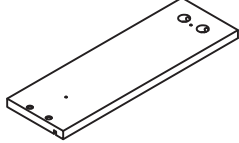
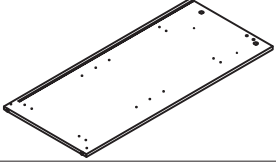
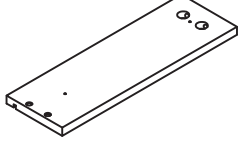
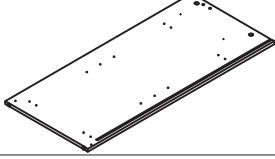
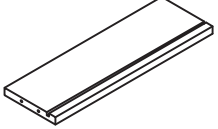
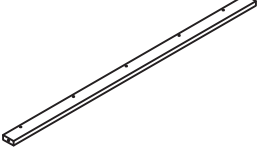
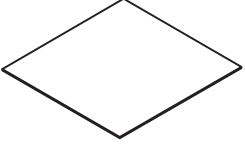
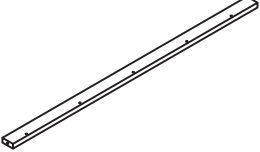
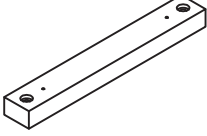
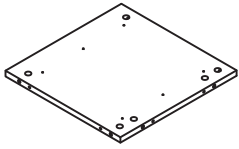
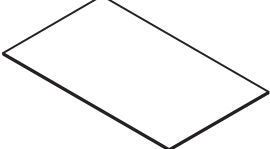



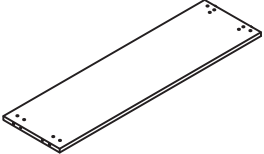
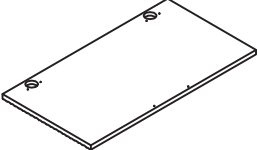













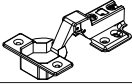
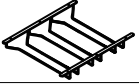

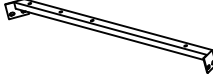

Parts List

ITEM	PART	QTY	ITEM	PART	QTY
①		1PC	⑫		2PC
②		1PC	⑬		2PC
③		1PC	⑭		2PC
④		1PC	⑮		4PC
⑤		1PC	⑯		2PC
⑥		1PC	⑰		2PC
⑦		1PC	⑱		2PC
⑧		1PC	⑲		2PC
⑨		1PC	⑳		2PC
⑩		1PC	㉑		2PC
⑪		2PC	㉒		2PCS

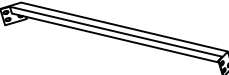
Parts List

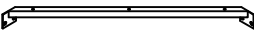
ITEM	PART	QTY
23		1PC
24		2PC
25		4PC

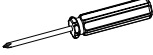
Hareware List

ITEM	PART	QTY	ITEM	PART	QTY
A	 Ø6x35mm	66+5 PCS	M		8+1 PCS
B	 Ø15x10mm	66+5 PCS		 Ø6x3x16mm	8+1 PCS
C	 Ø6x30mm	46+4 PCS	N	 Ø20mm	22+2 PCS
D	 Ø5x38mm	8+1 PCS	O	 4mm	1 PCS
E		4 PCS	P		1 PCS
F	 Ø7x3.5x12mm	56+6 PCS	Q		1 PCS
G		1 PCS	R		1 PCS
H	 M6x10mm	24+2 PCS	S		1 PCS
I	 M6x28mm	23+2 PCS	T		1 PCS
J	 L=285mm	2 PCS	U		1 PCS
K		2 PCS			1 PC
L		8+1 PCS			

Before installing the drawer rail, you need to separate the Part-1 and Part-2 first.

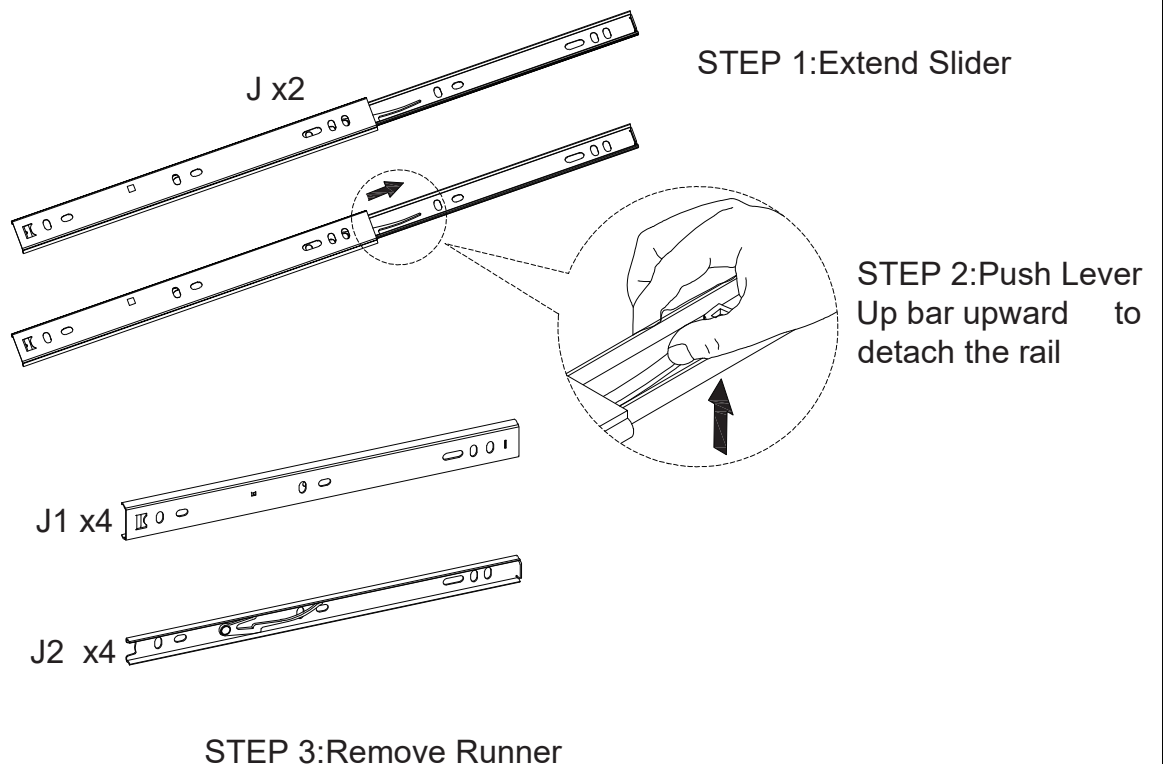

Hardware List

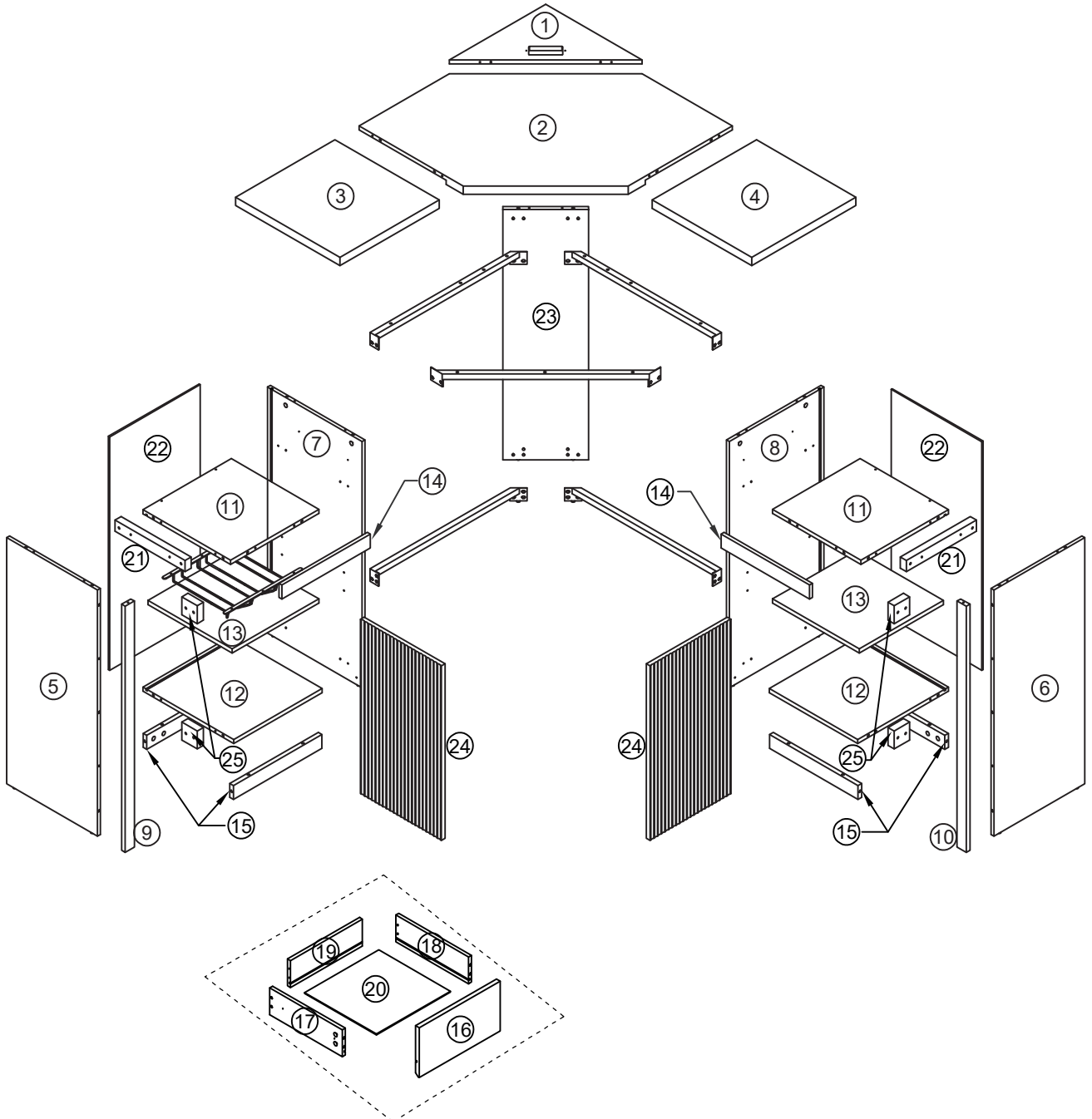

X 2

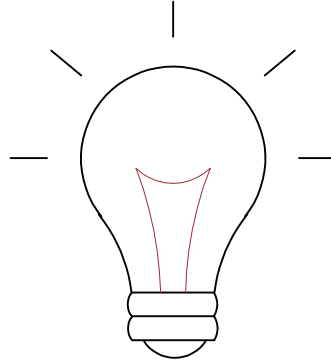

friendly reminder

To avoid errors and confusion during the installation of accessories, use the type and quantity of hardware accessories according to the installation procedure described in the instructions. First, unroll the accessories bag and lay out the hardware accessories, cut holes in the side, and take out the hardware accessories

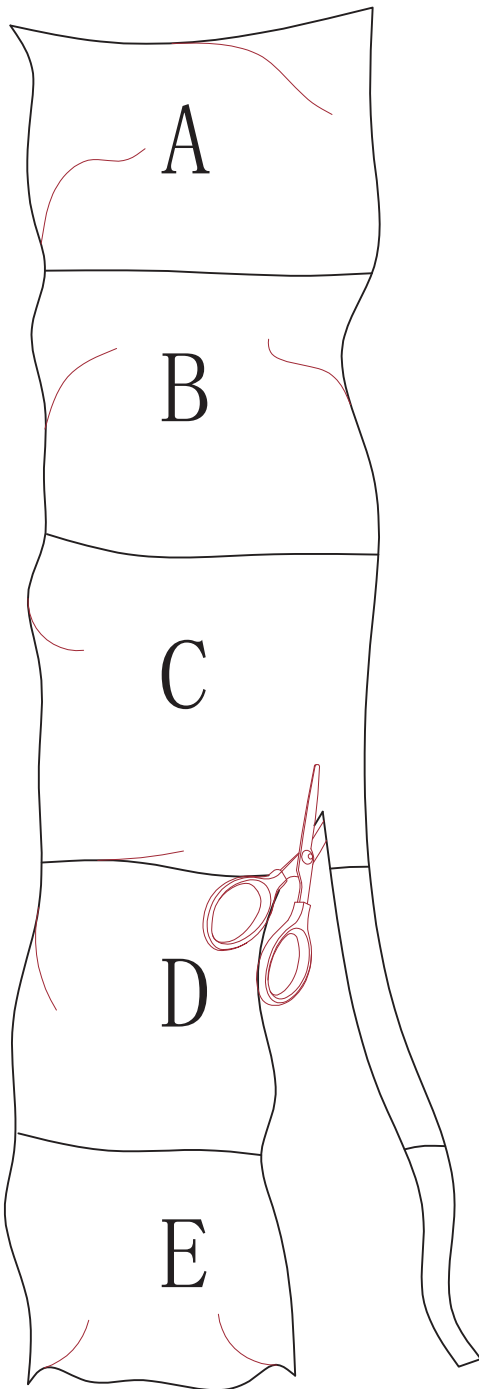

01

Please pay attention to the installation direction of the P accessory (front and back).

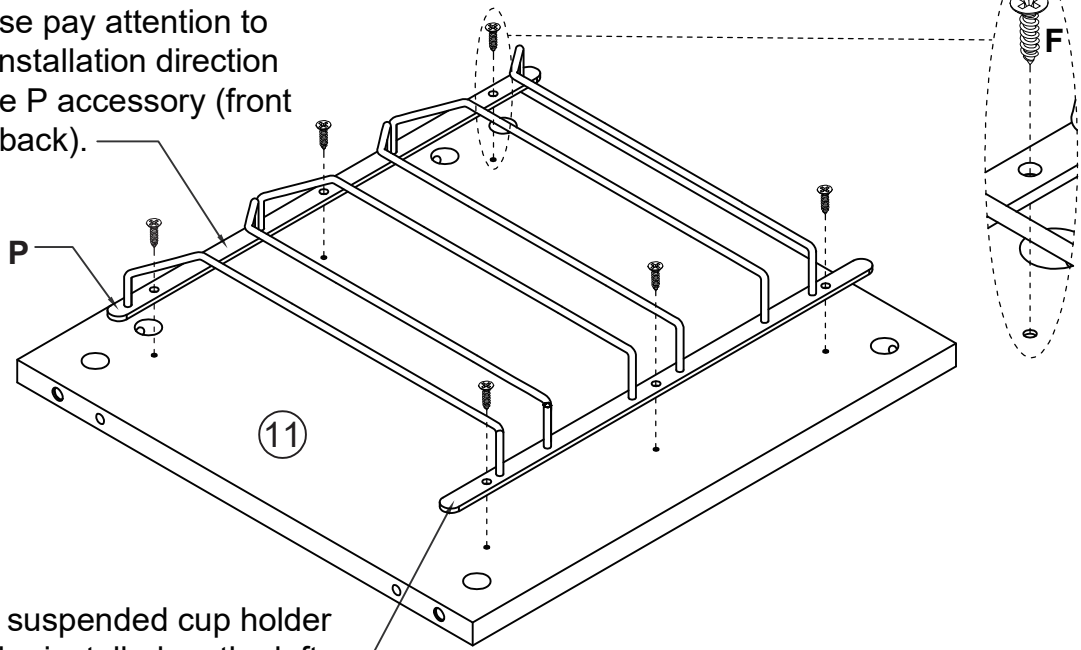

This suspended cup holder can be installed on the left cabinet or the right cabinet.

Install P to Part #11 with screws F x6 as shown.

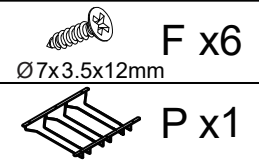

02

X 2

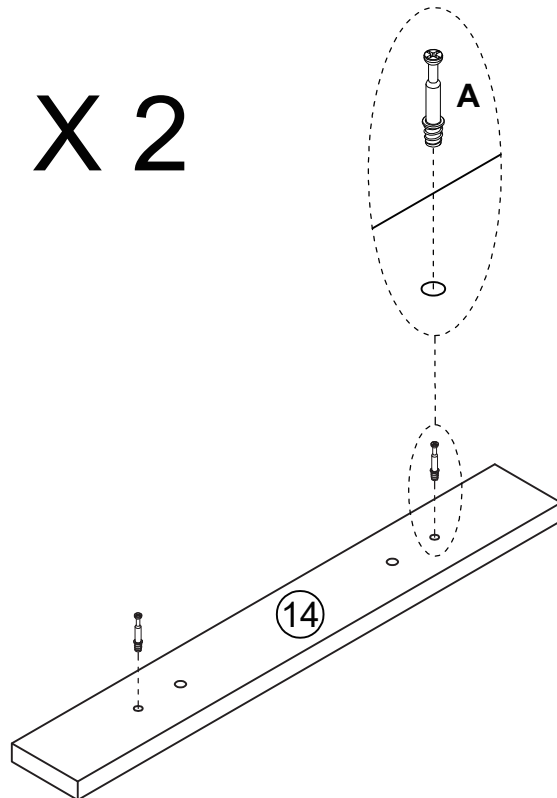

Install Cam Bolt A x4 to Part #14 x2 as shown.



03

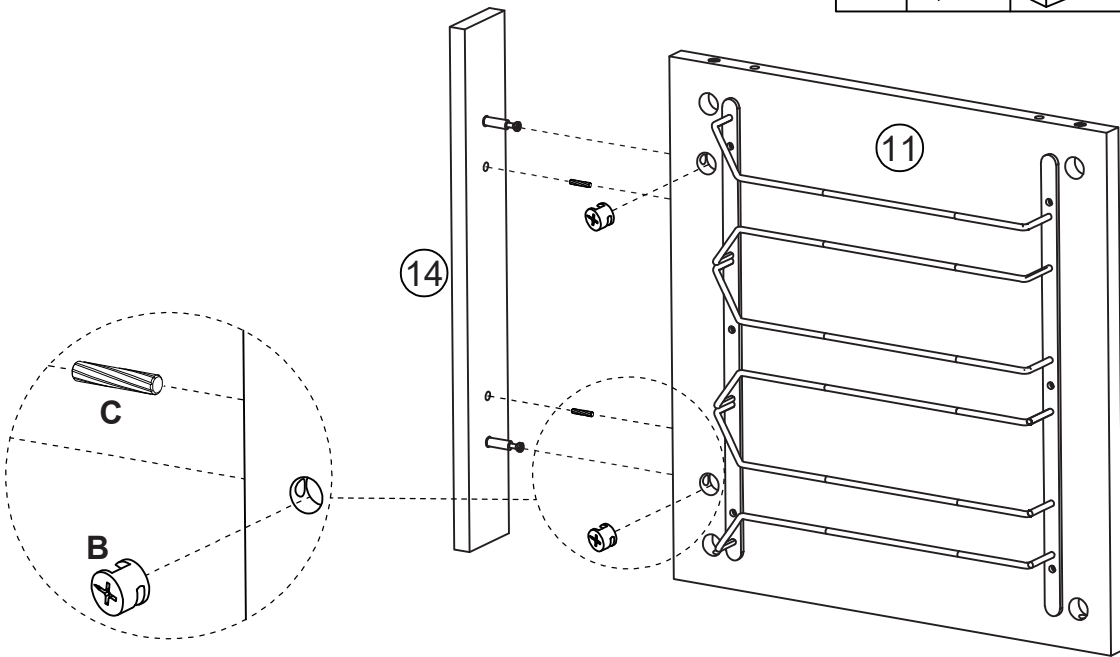
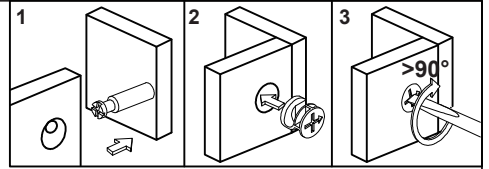

Attach Part #14 to Part #11 with dowel C x2 and nuts B x2 as shown.
Turn nuts B x2 to secure position.

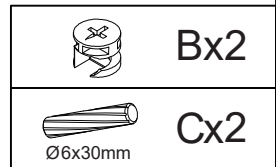

04

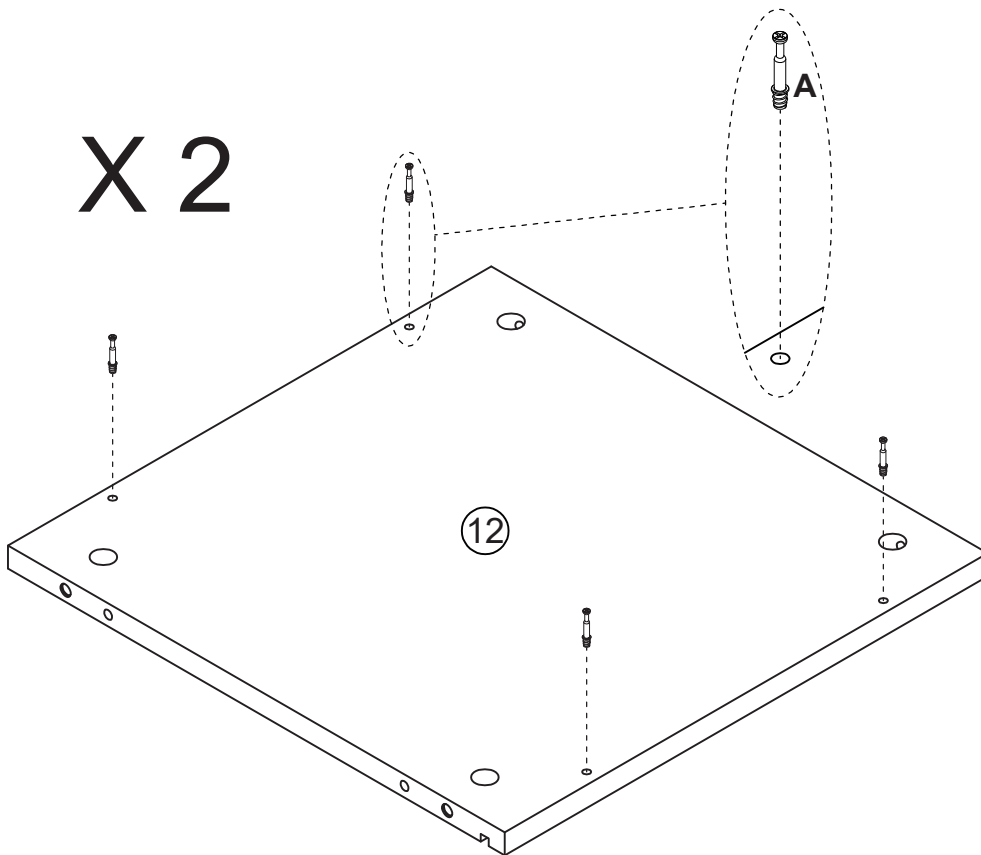

Install Cam Bolt A x8 to Part #12 x2 as shown.

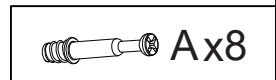

05

X 2

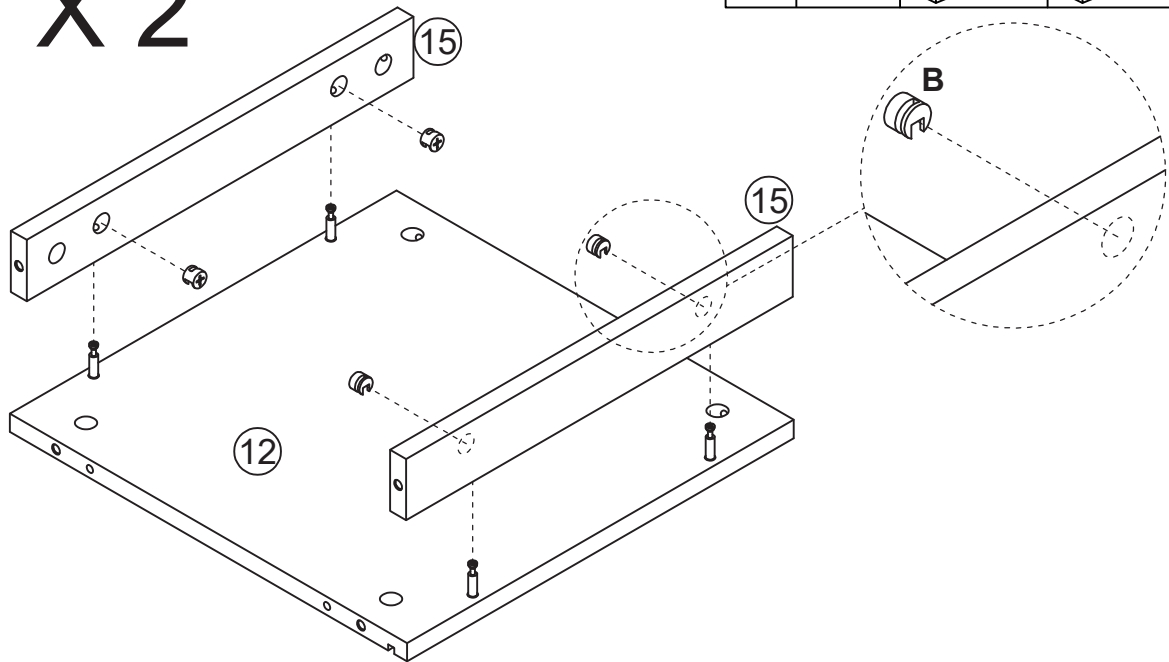

Attach Part #15 x4 to Part #12 x2 with nuts B x8 as shown.
Turn nuts B x8 to secure position.



Bx8

06

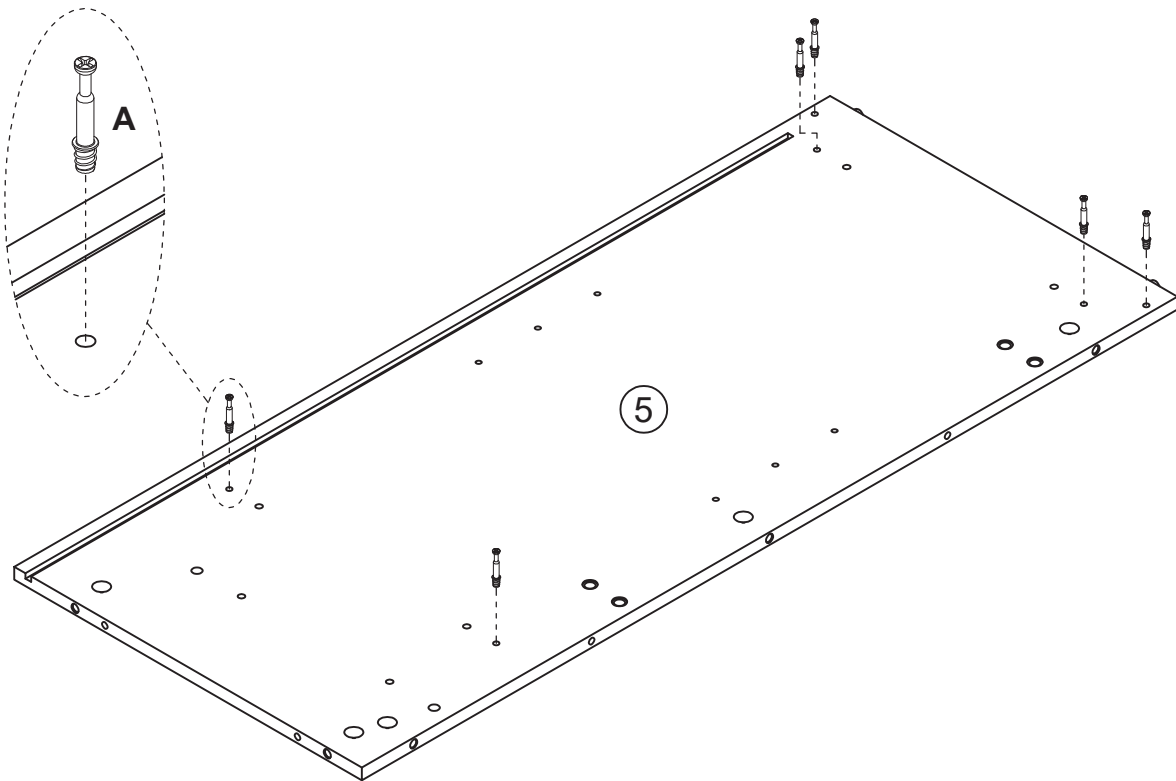

Install Cam Bolt A x6 to Part #5 as shown.



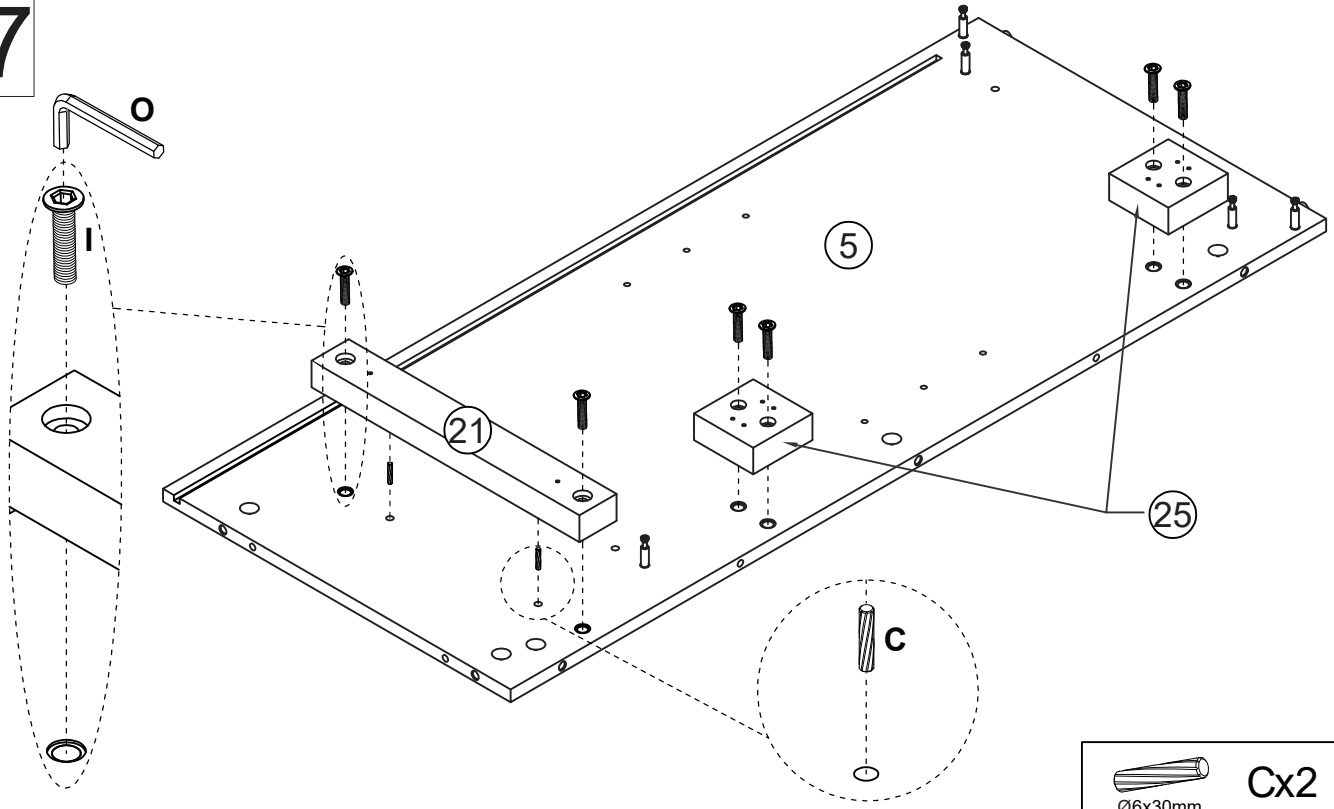

Ax6

07

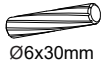

Attach Part #21 to Part #5 with dowel C x2 and screws I x2 as shown.
 Attach Part #25 x2 to Part #5 with screws I x4 as shown.
 Then secure with tool O as shown.

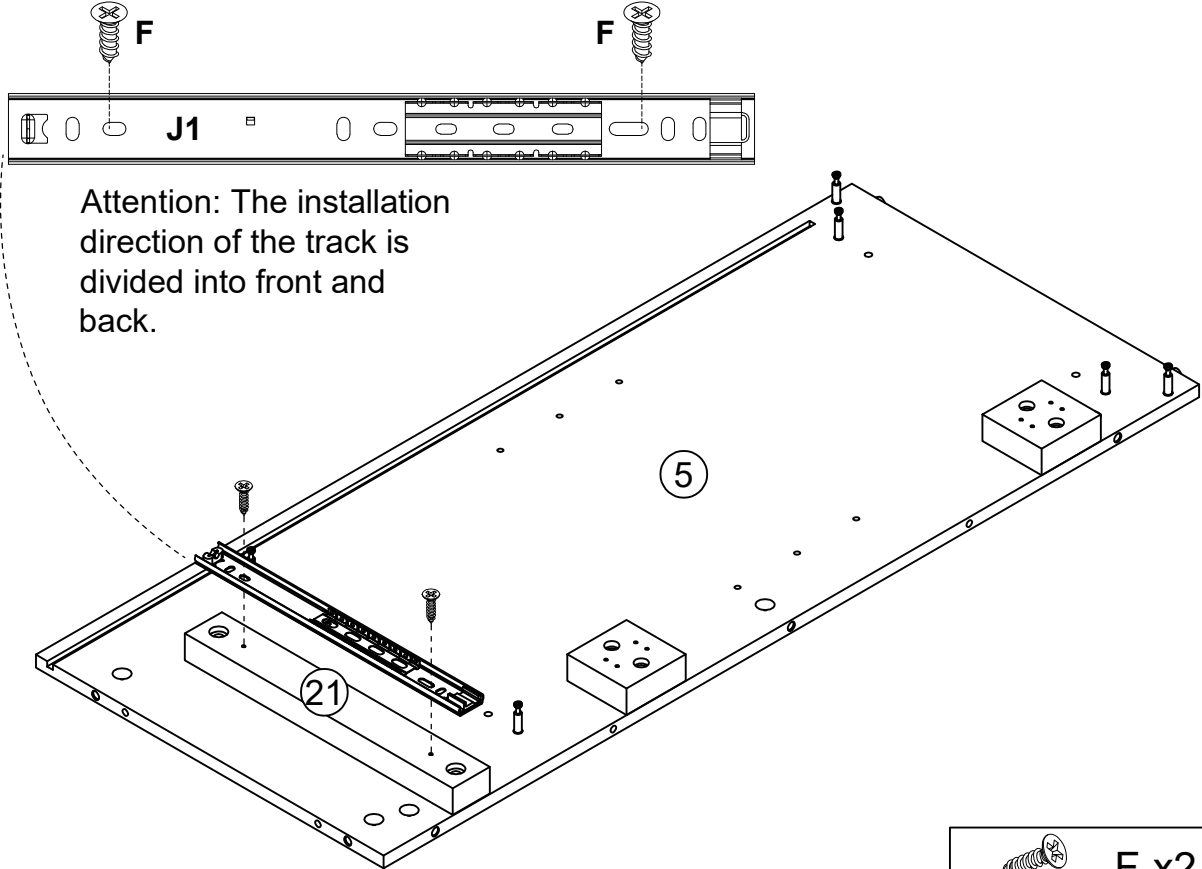

	C x 2
$\text{Ø}6 \times 30 \text{mm}$	
	I x 6
M6 x 28mm	
	O x 1
4mm	

08



Attention: The installation direction of the track is divided into front and back.

Install the outer rail J1 to Part #21 with screws F x2 as shown.

	F x 2
$\text{Ø}7 \times 3.5 \times 12 \text{mm}$	
	J1 x 1
L=285mm	

09

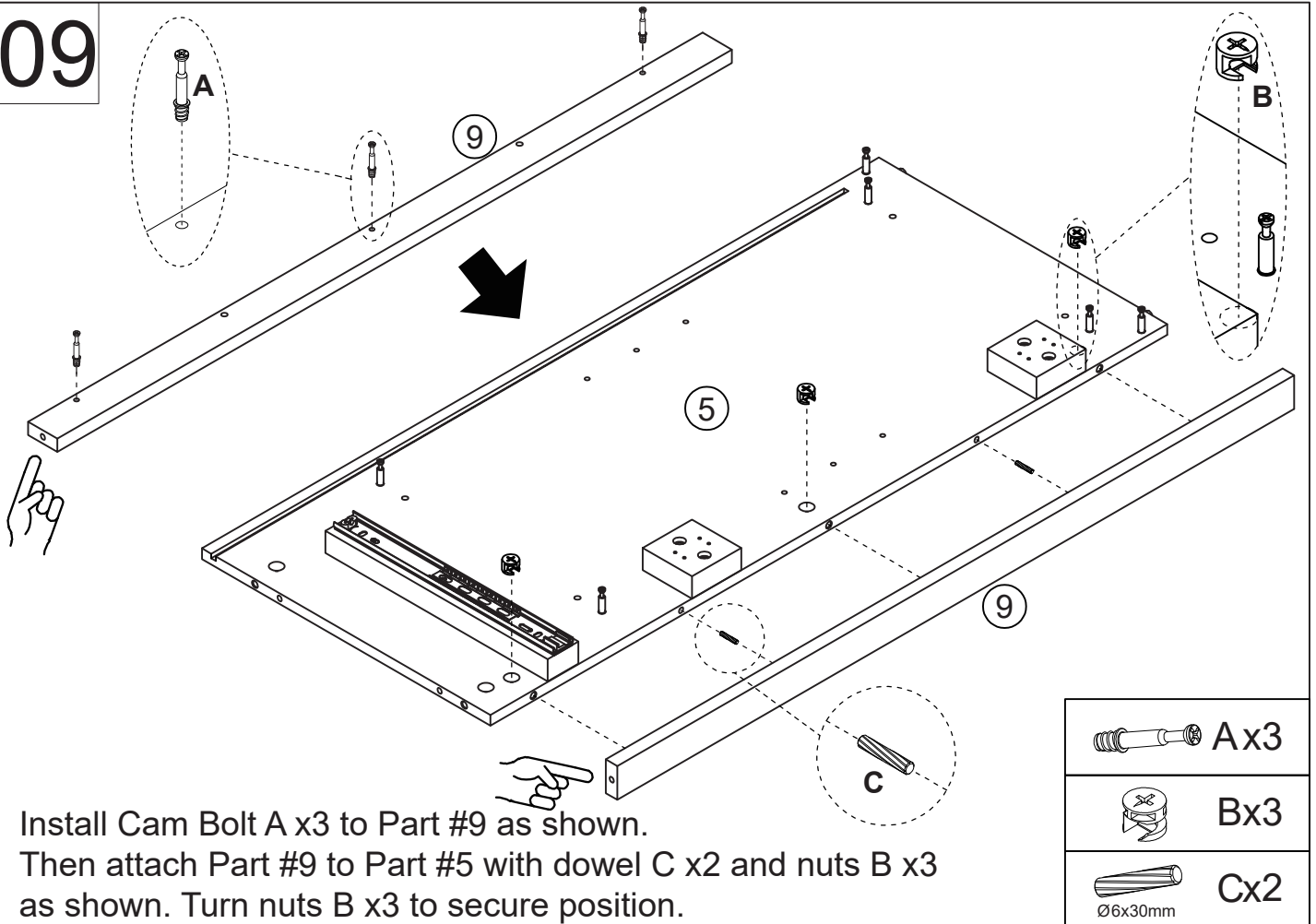

10

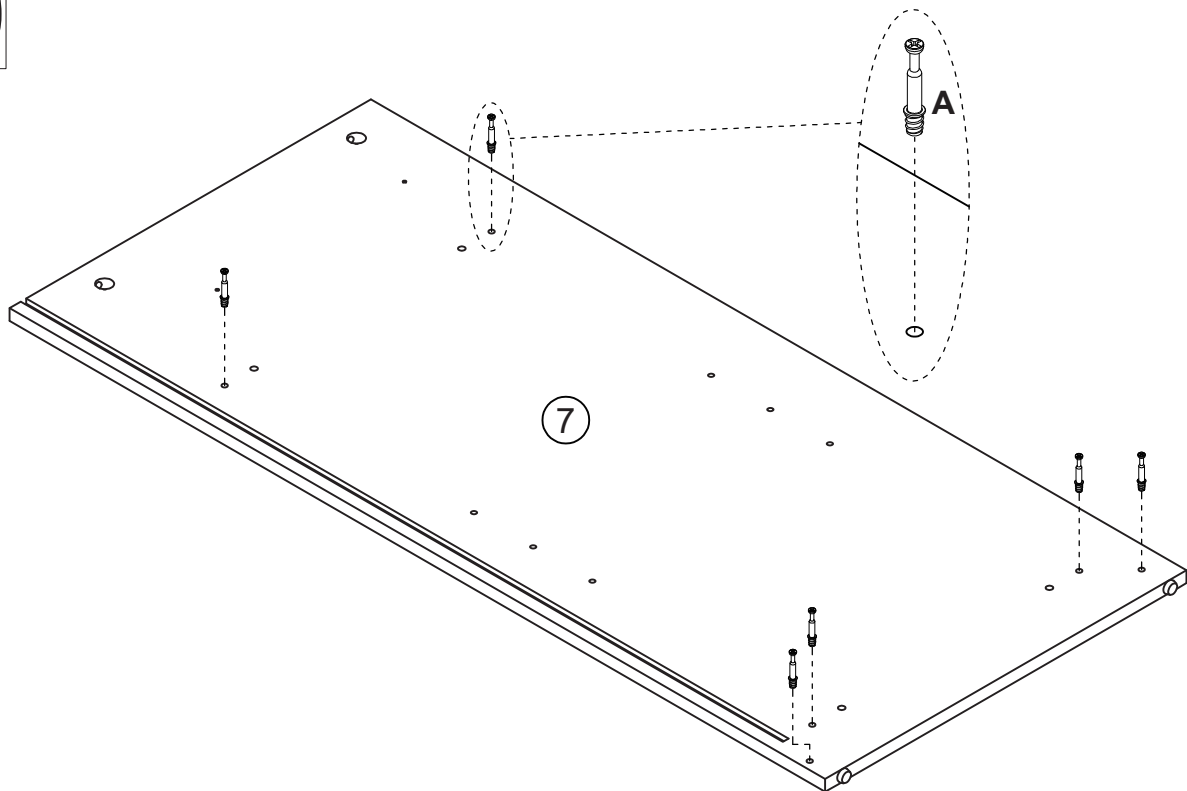

11

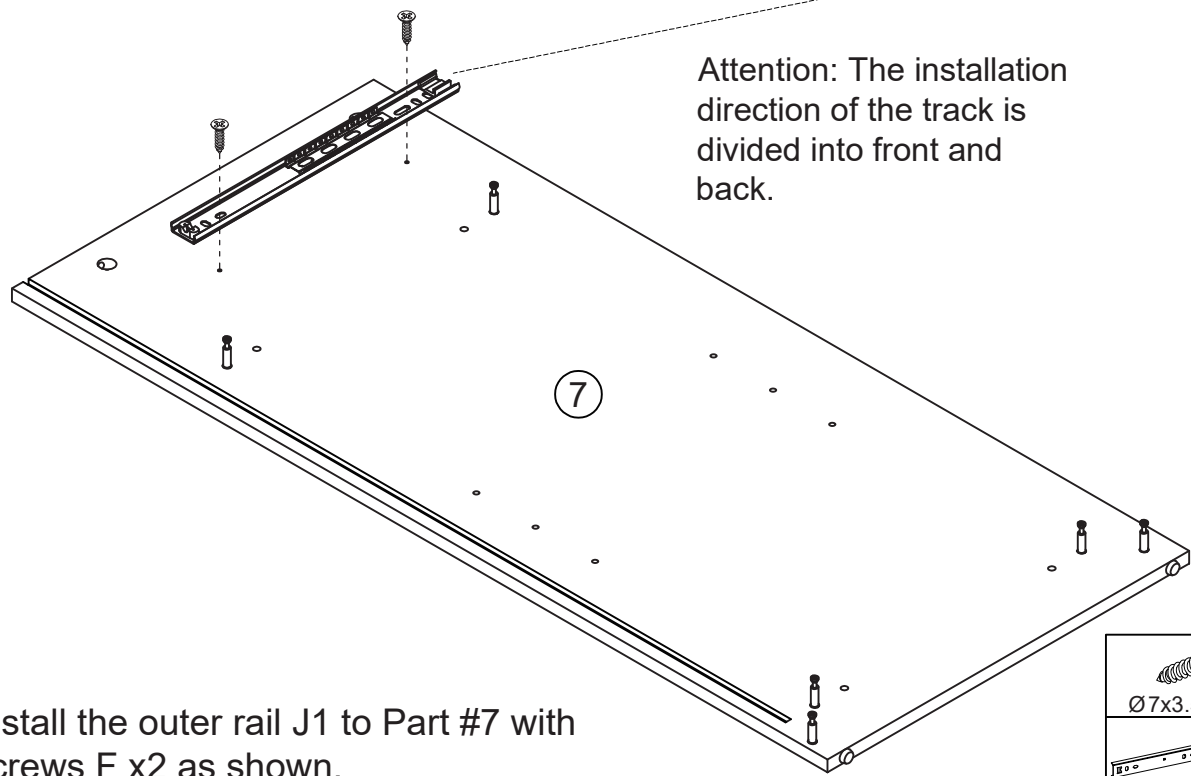
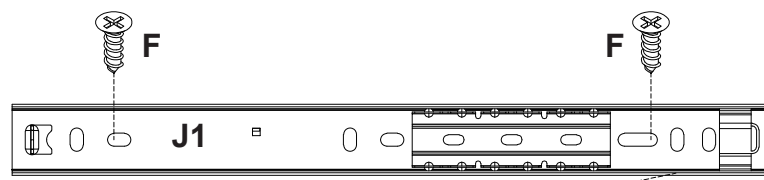

Attention: The installation direction of the track is divided into front and back.

Install the outer rail J1 to Part #7 with screws F x2 as shown.

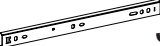
	F x2
Ø7x3.5x12mm	
	J1x1
L=285mm	

12

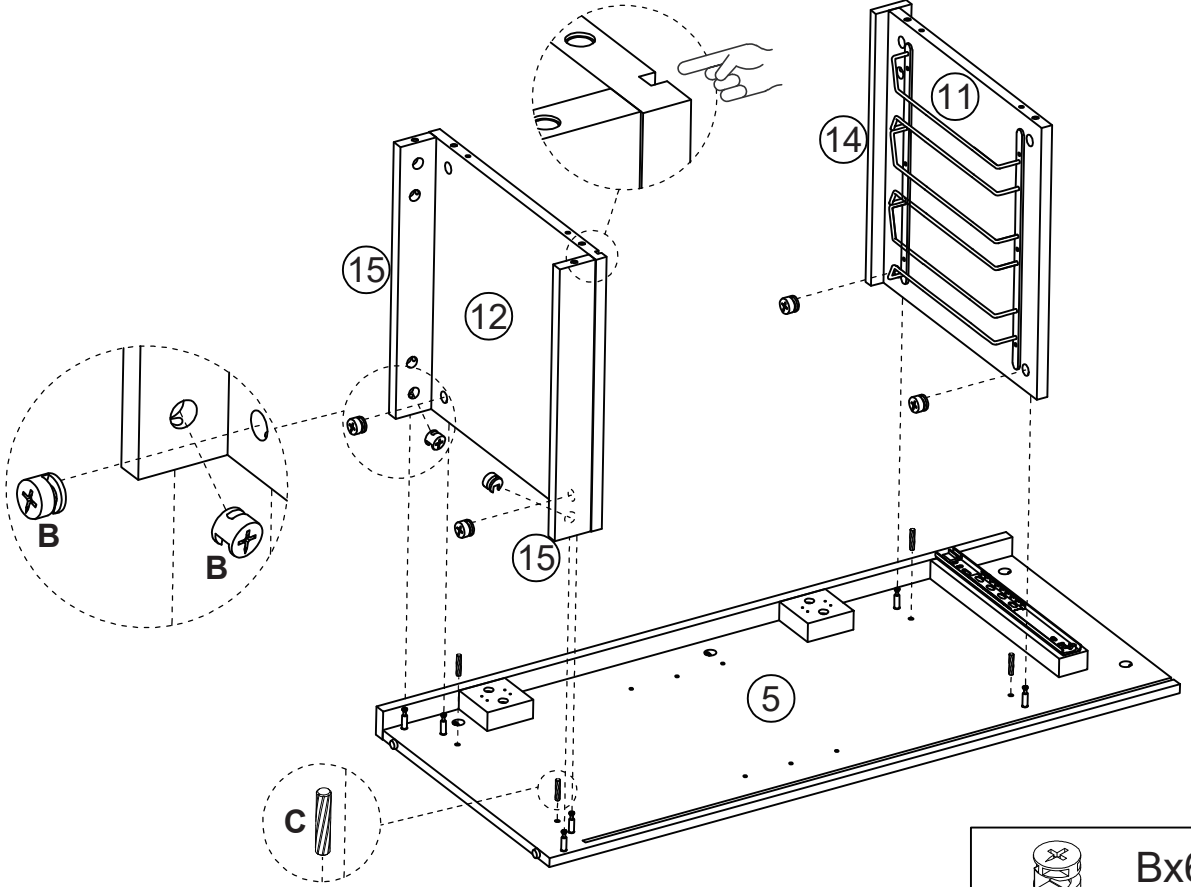
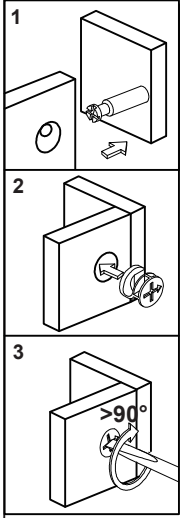

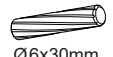

Attach the assembled unit from step 3 & step 5 to Part #5 with dowel C x4 and nuts B x6 as shown. Turn nuts B x6 to secure position.

	Bx6
	Cx4
Ø6x30mm	

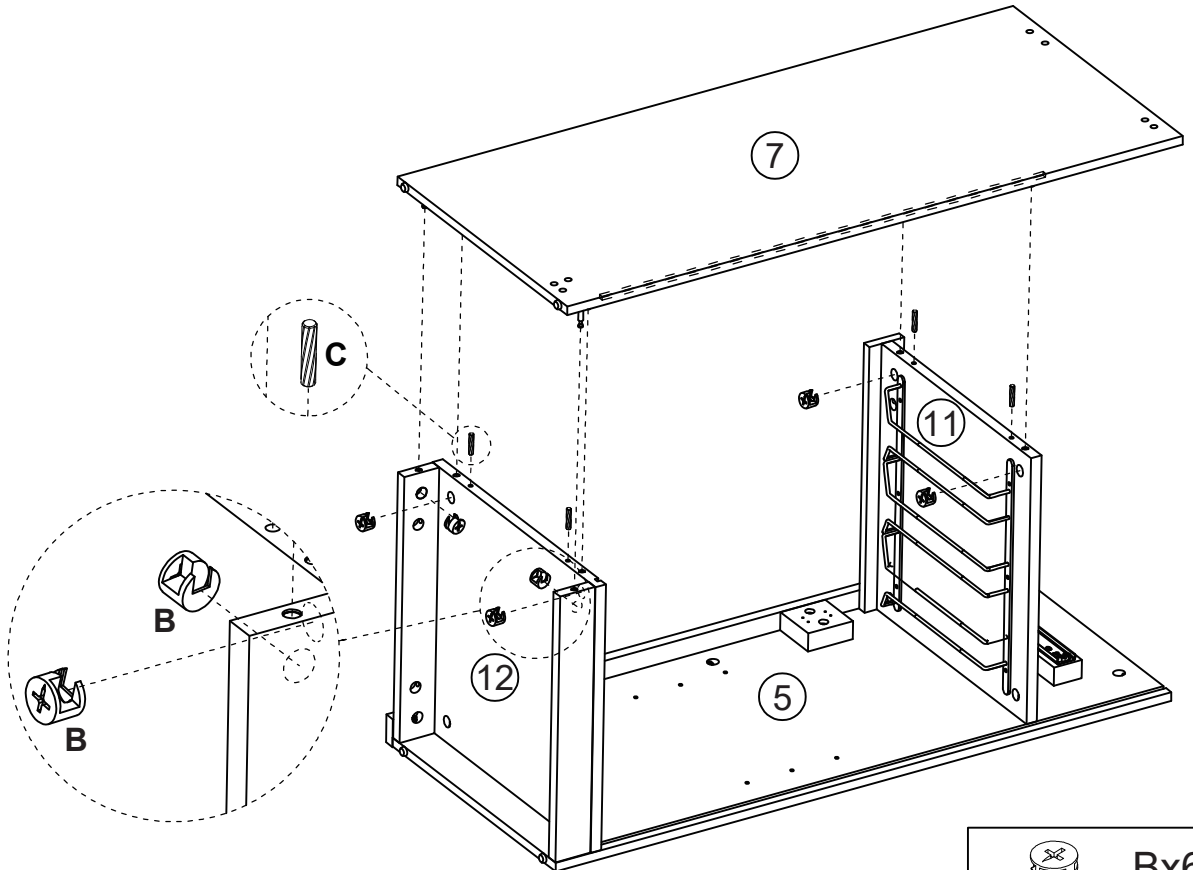
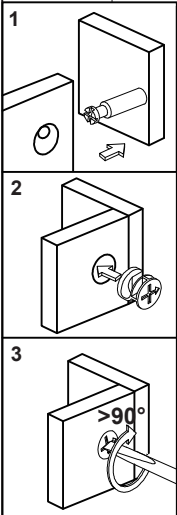
13



Attach Part #7 to the Part #11&12 from step 12 with dowel C x4 and nuts B x6 as shown. Turn nuts B x6 to secure position.

	Bx6
	Cx4 Ø6x30mm

14

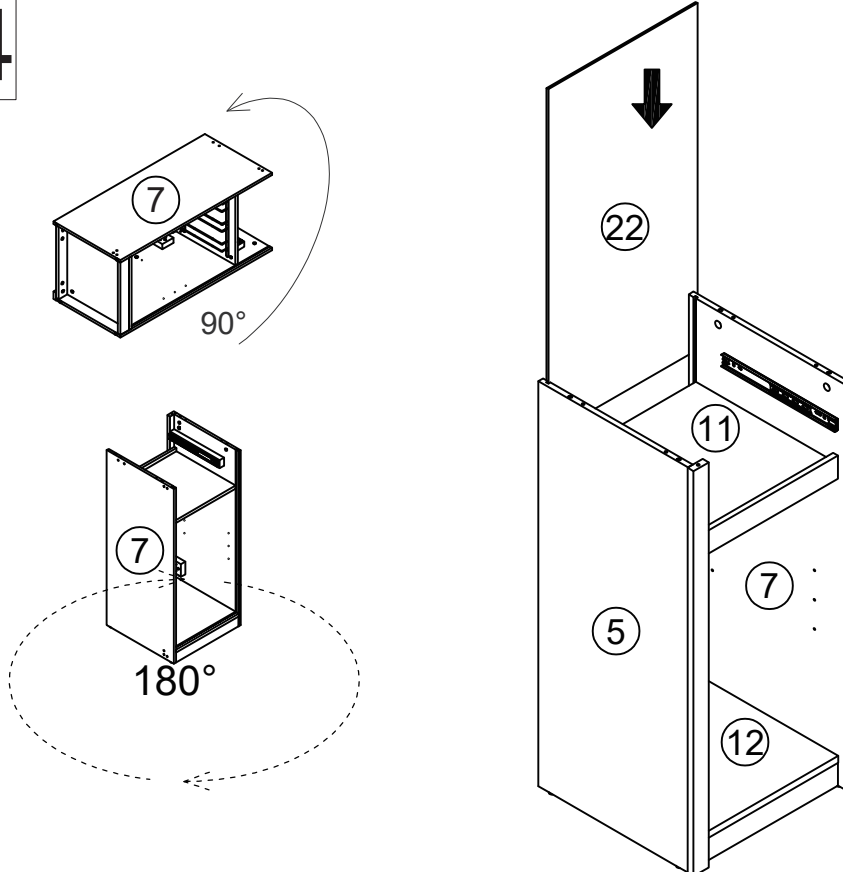

The thin plate needs to be fully inserted into the groove. If the insertion is not smooth, you can try pressing from the front or the back to make adjustments until the thin plate is fully inserted into the groove.

Turn the assembled unit 90°, then turn it 180° as shown. Insert Part #22 straight down into the grooves of the assembled unit as shown.

15

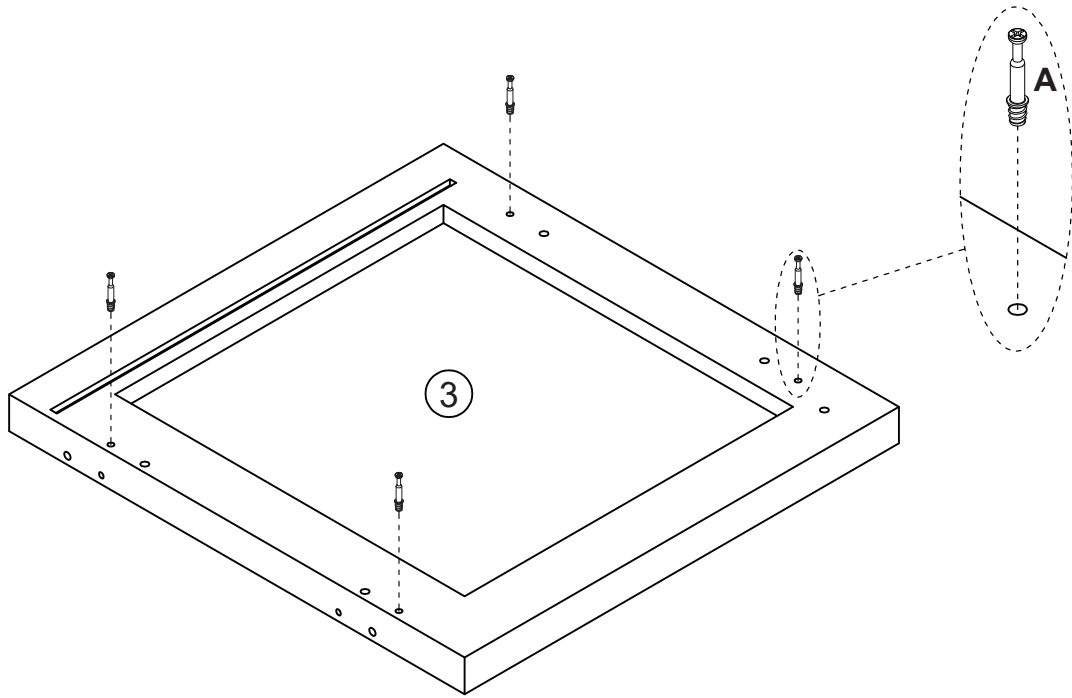

Install Cam Bolt A x4 to Part #3 as shown.



16

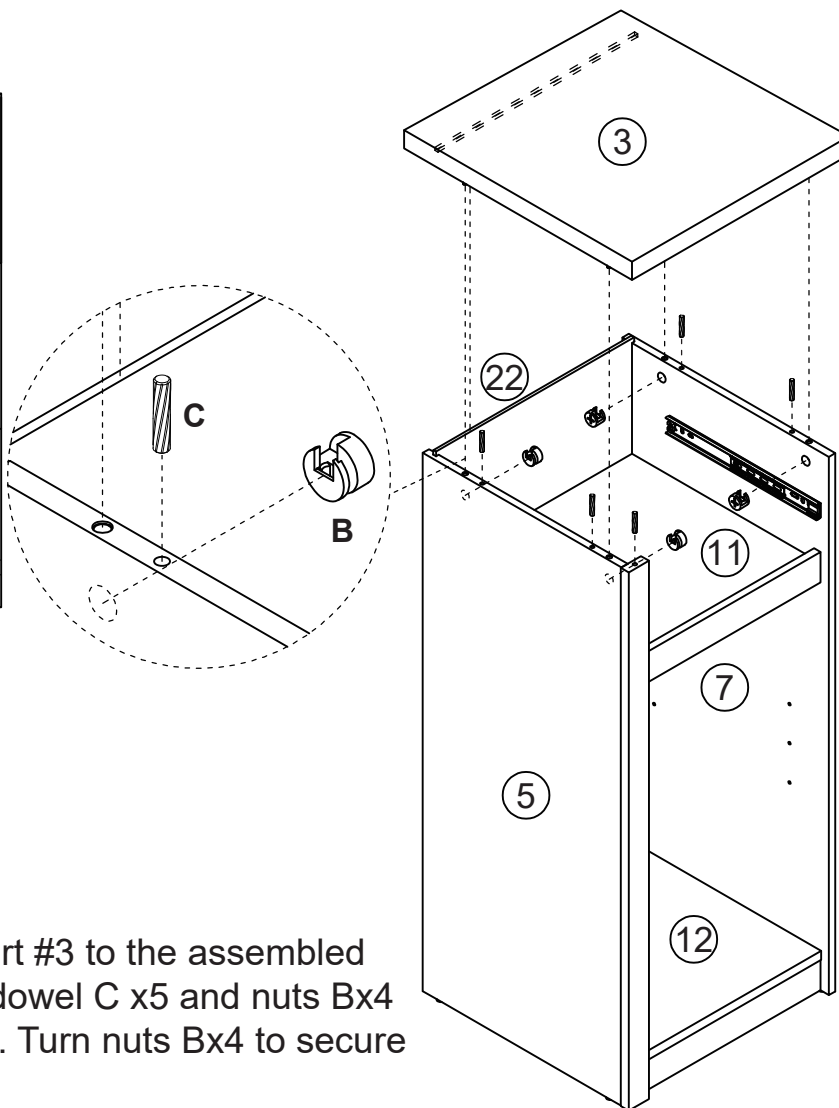
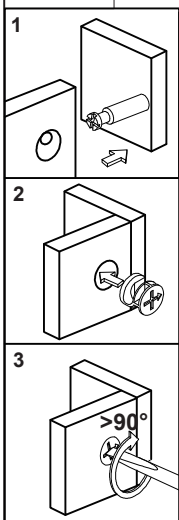

The thin plate needs to be fully inserted into the groove. If the insertion is not smooth, you can try pressing from the front or the back to make adjustments until the thin plate is fully inserted into the groove.

Attach Part #3 to the assembled unit with dowel C x5 and nuts Bx4 as shown. Turn nuts Bx4 to secure position.

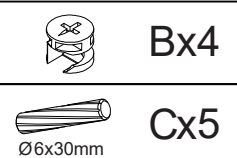

17

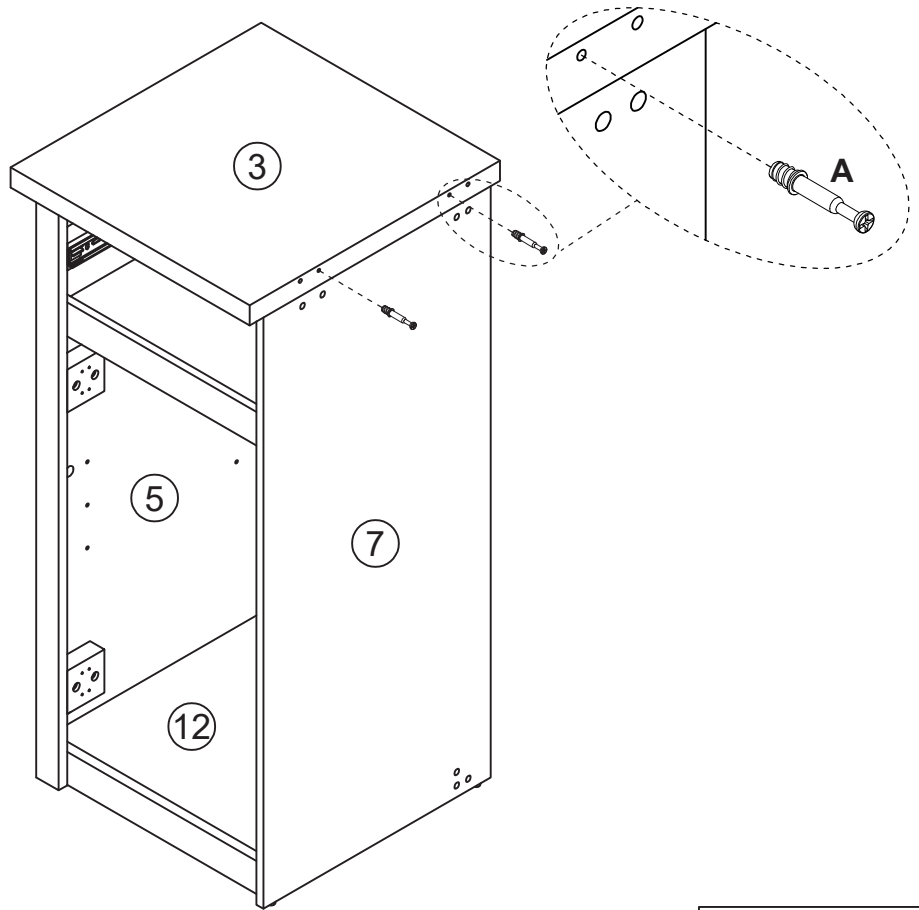

Install Cam Bolt A x2 to the assembled unit as shown.



18

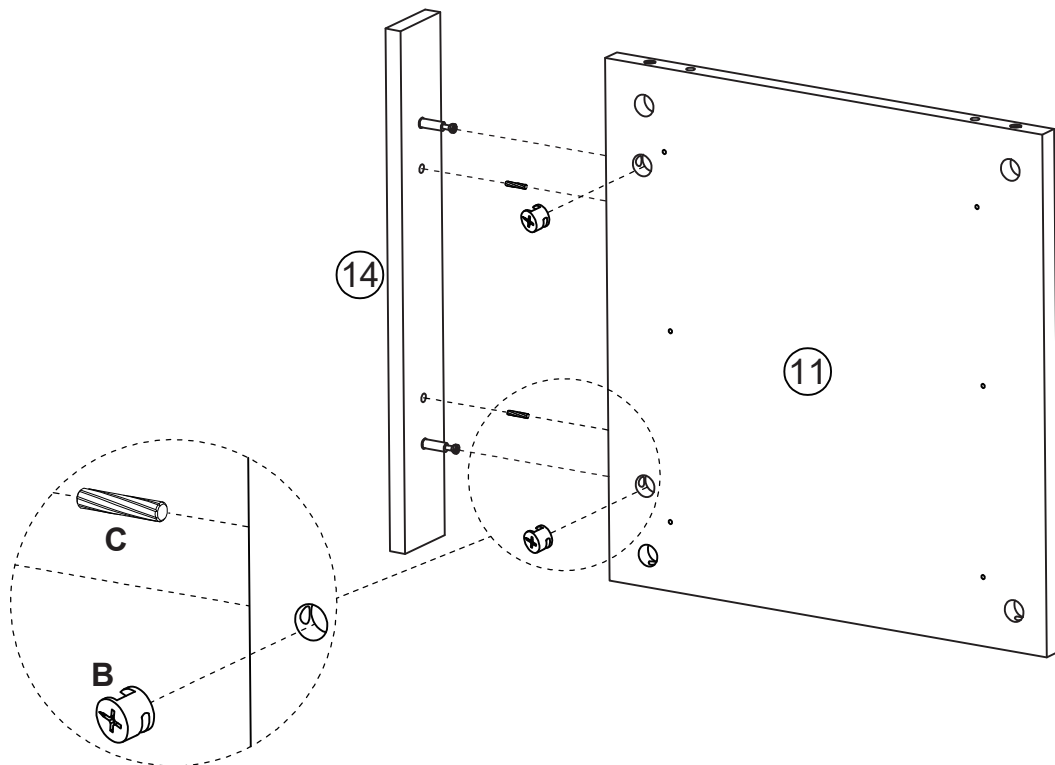
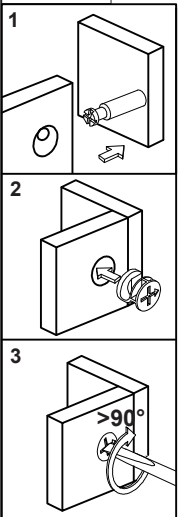

Attach Part #14 from step 2 to Part #11 with dowel C x2 and nuts B x2 as shown. Turn nuts B x2 to secure position.



19

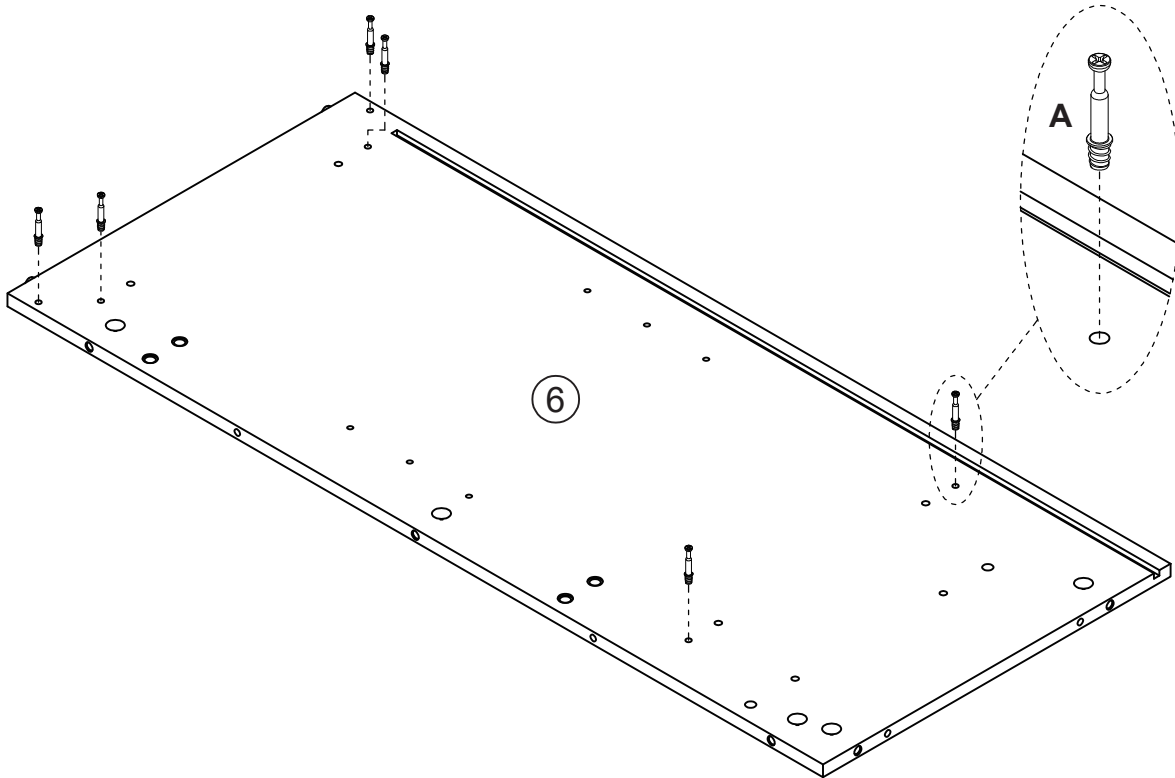

Install Cam Bolt A x6 to Part #6 as shown.

 Ax6

20

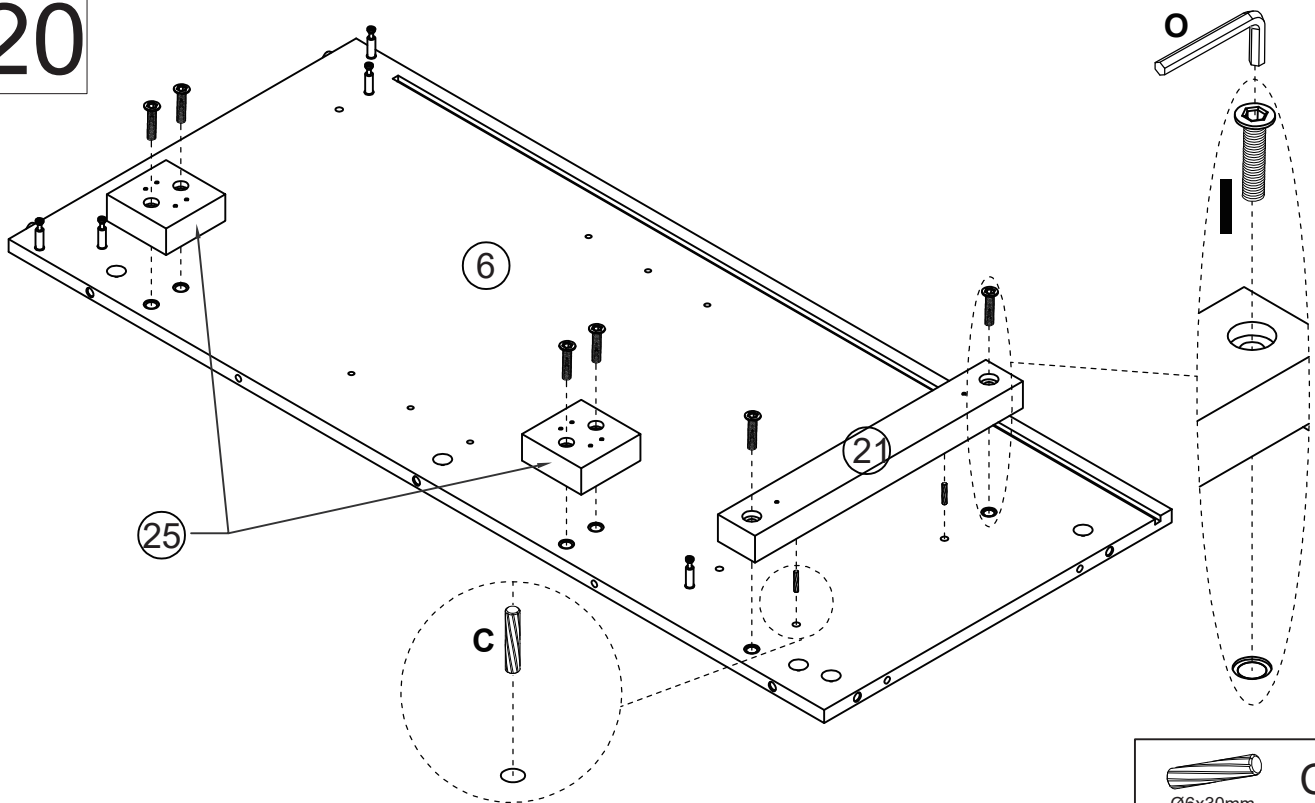

Attach Part #21 to Part #6 with dowel C x2 and screws I x2 as shown.
Attach Part #25 x2 to Part #6 with screws I x4 as shown.
Then secure with tool O as shown.

 Cx2
Ø6x30mm

 I x6
M6x28mm

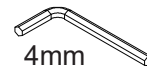
 O x1
4mm

21

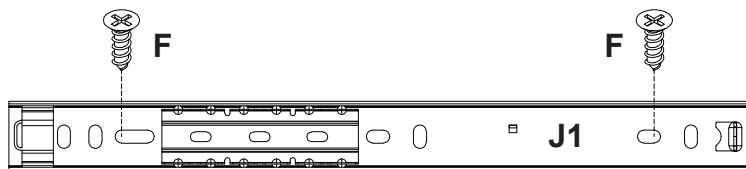

Attention: The installation direction of the track is divided into front and back.

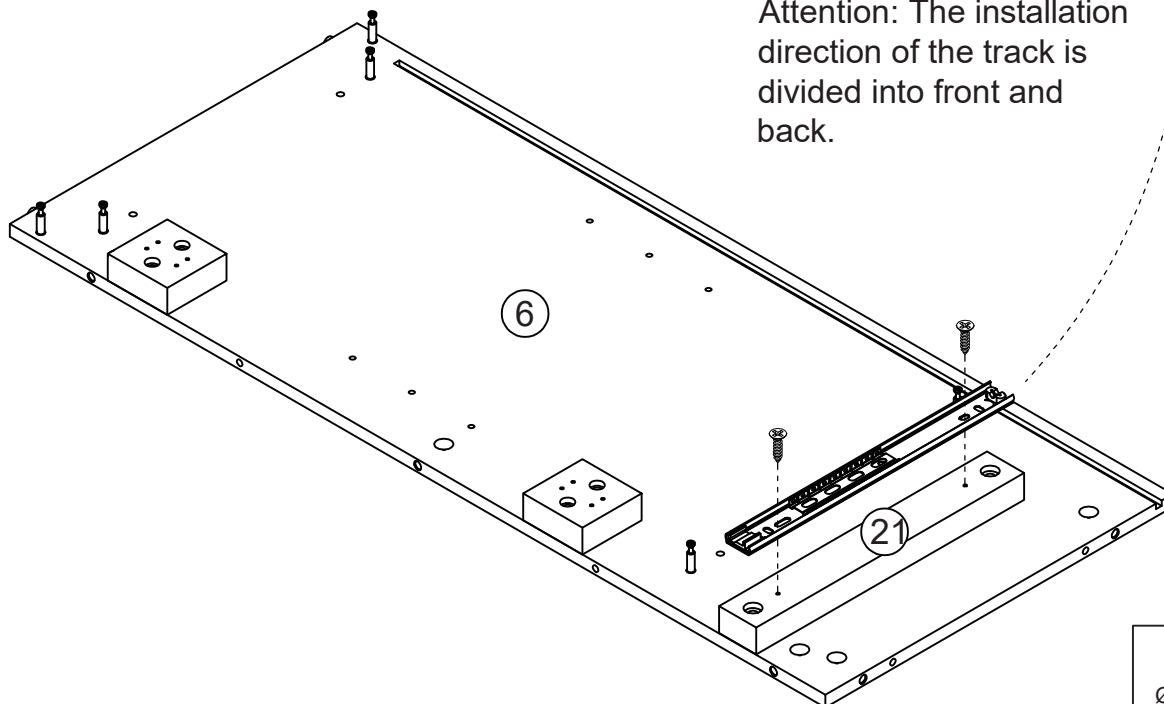

Install the outer rail J1 to Part #21 with screws F x2 as shown.

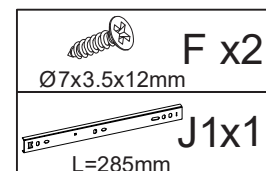

22

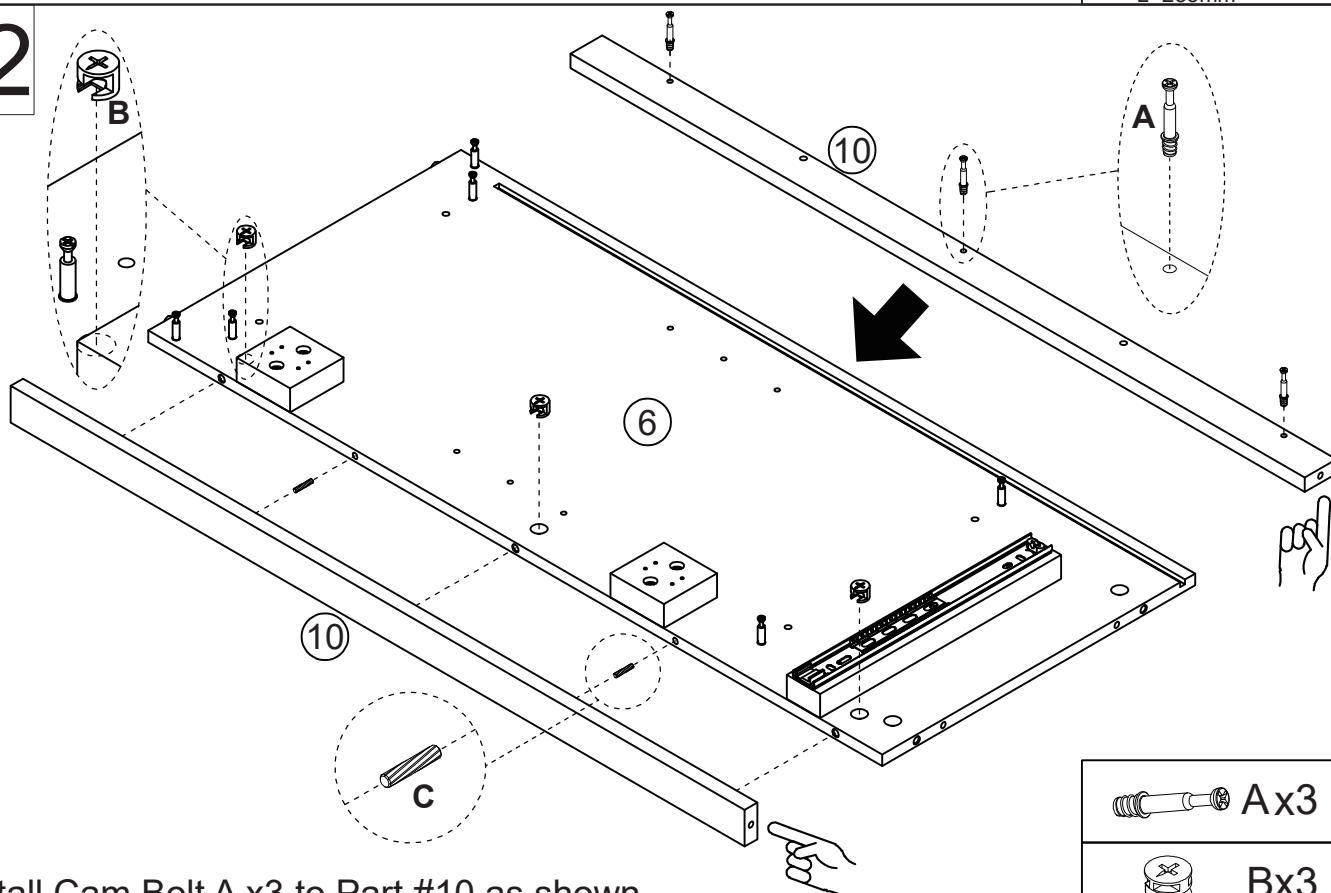

Install Cam Bolt A x3 to Part #10 as shown.
Then attach Part #10 to Part #6 with dowel C x2 and nuts B x3 as shown. Turn nuts B x3 to secure position.

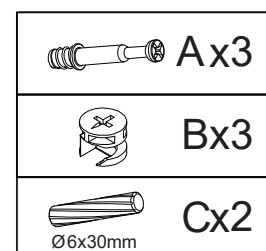

23

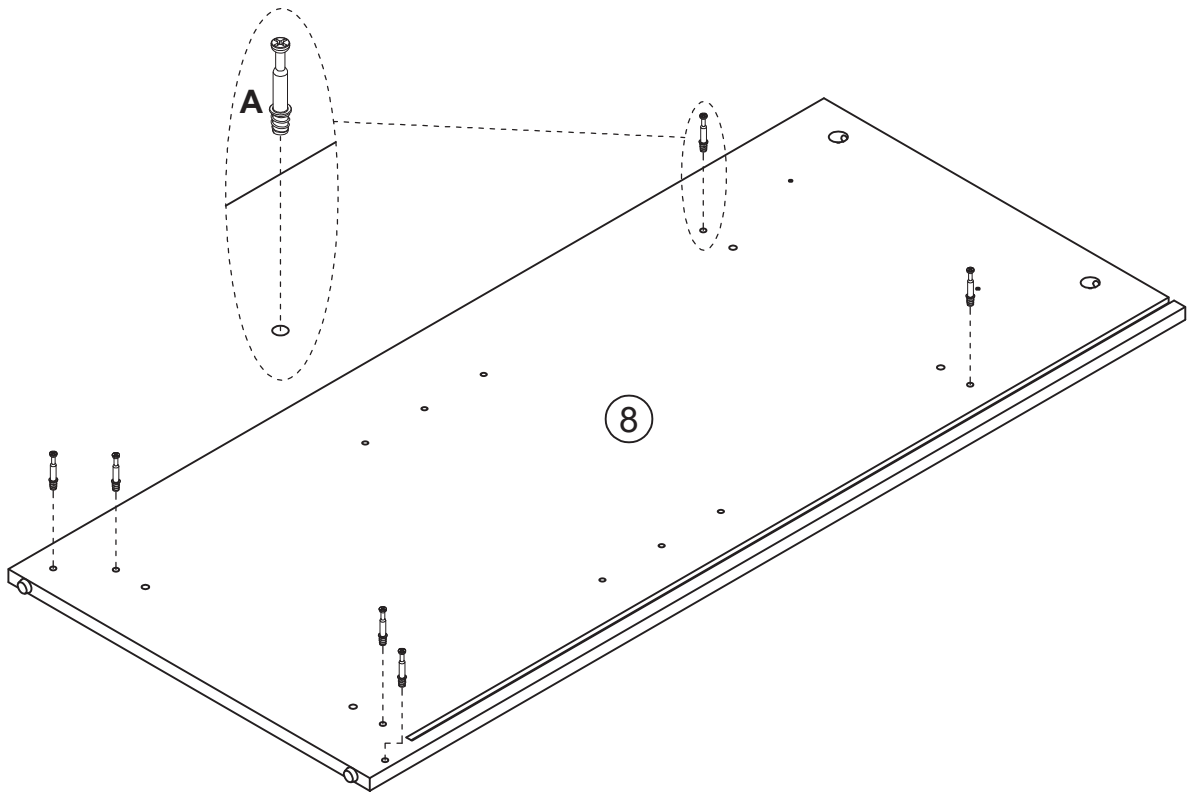

Install Cam Bolt A x6 to Part #8 as shown.



24

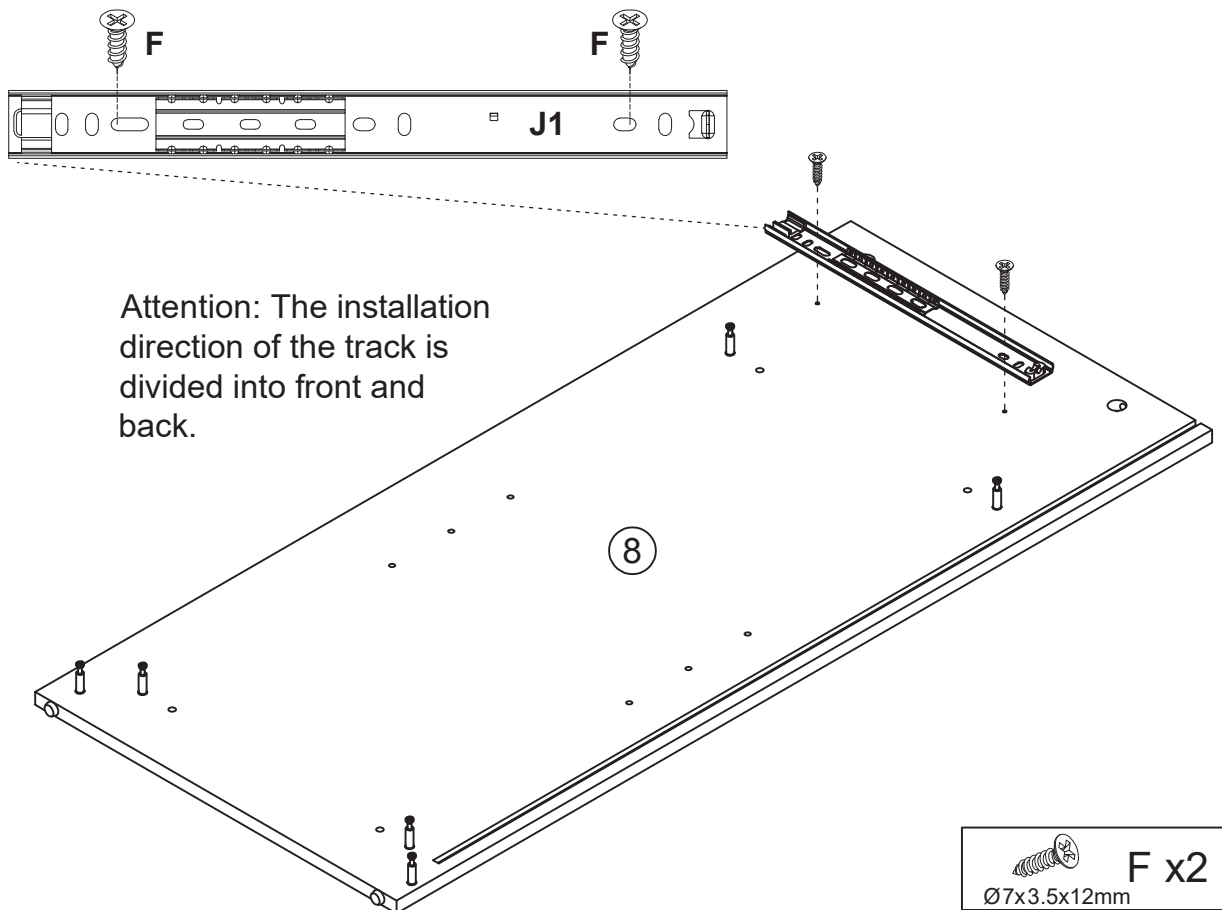

Attention: The installation direction of the track is divided into front and back.

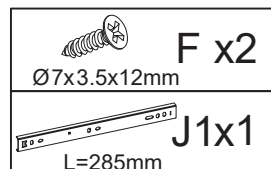

Install the outer rail J1 to Part #8 with screws F x2 as shown.



25

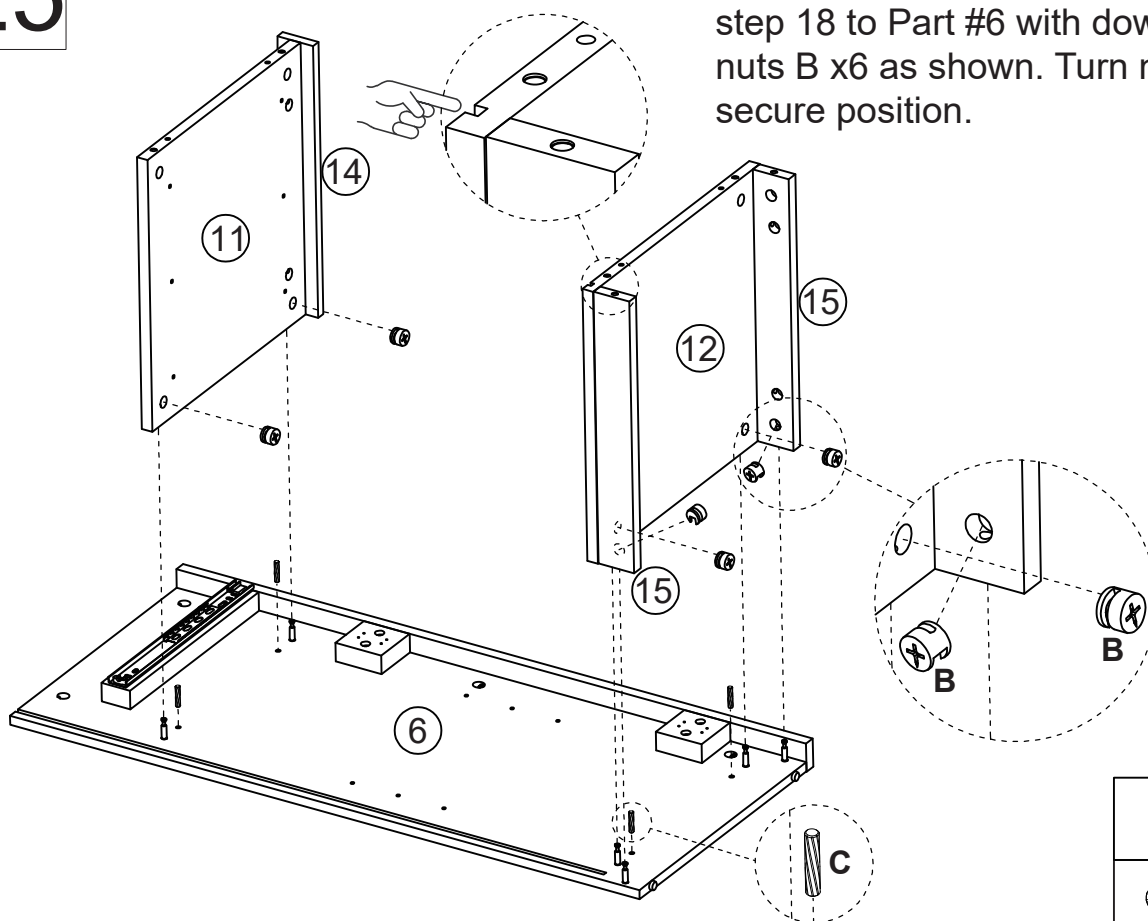

Attach the assembled unit from step 5 & step 18 to Part #6 with dowel C x4 and nuts B x6 as shown. Turn nuts B x6 to secure position.

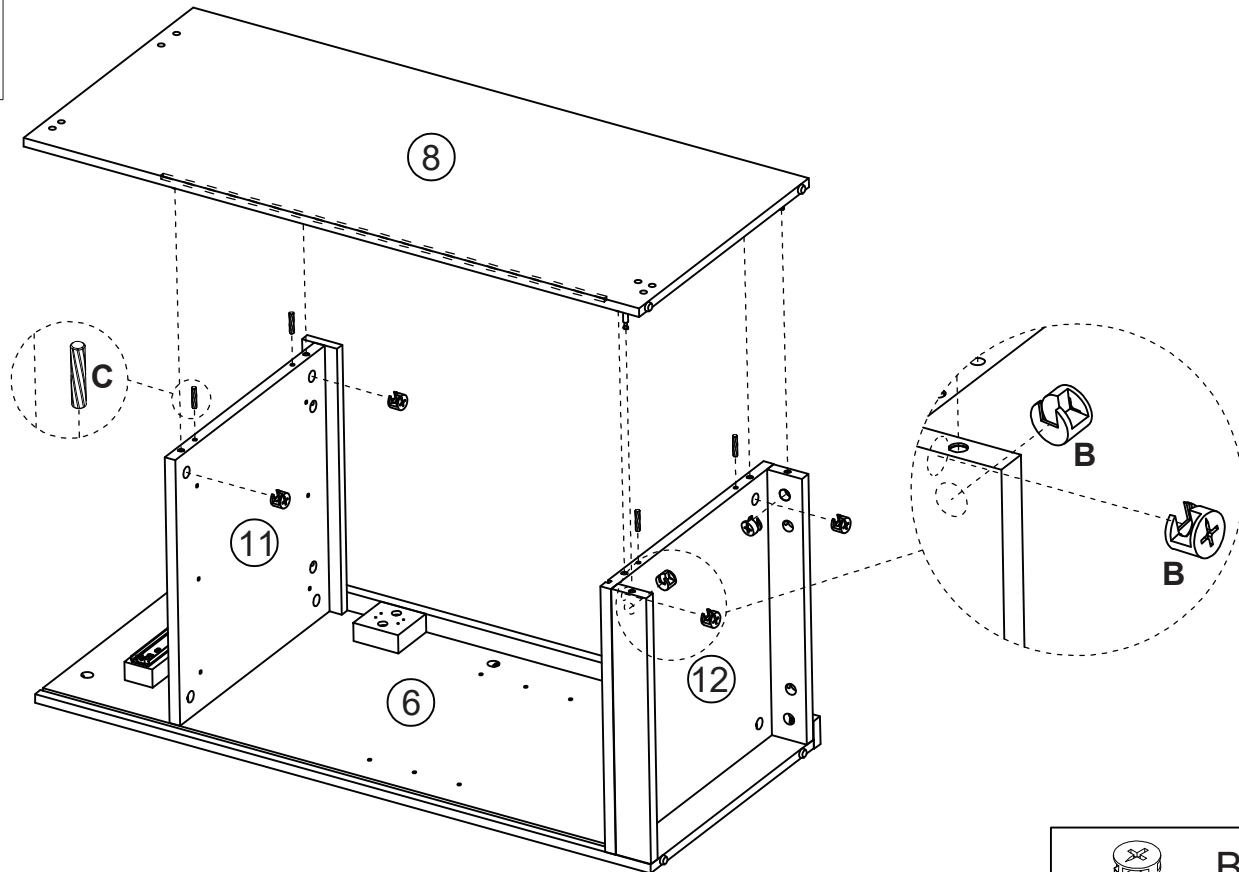

	Bx6
	Cx4
<small>Ø6x30mm</small>	

26



	Bx6
	Cx4
<small>Ø6x30mm</small>	

Attach Part #8 to the Part #11&12 from step 25 with dowel C x4 and nuts B x6 as shown. Turn nuts B x6 to secure position.

27

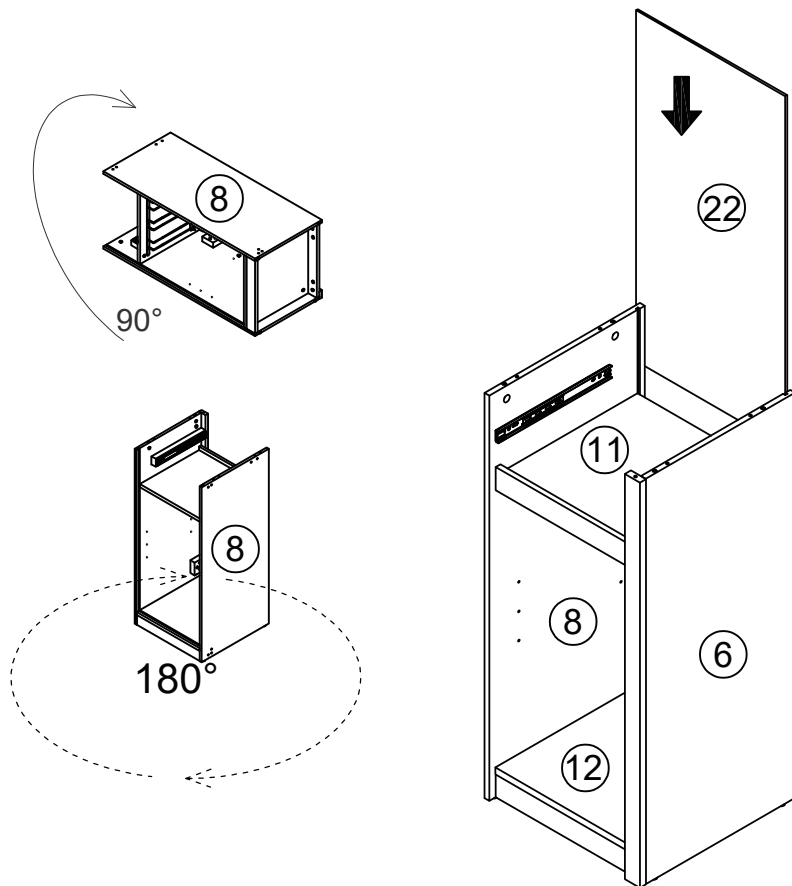

The thin plate needs to be fully inserted into the groove. If the insertion is not smooth, you can try pressing from the front or the back to make adjustments until the thin plate is fully inserted into the groove.

Turn the assembled unit 90°, then turn it 180° as shown.
Insert Part #22 straight down into the grooves of the assembled unit as shown.

28

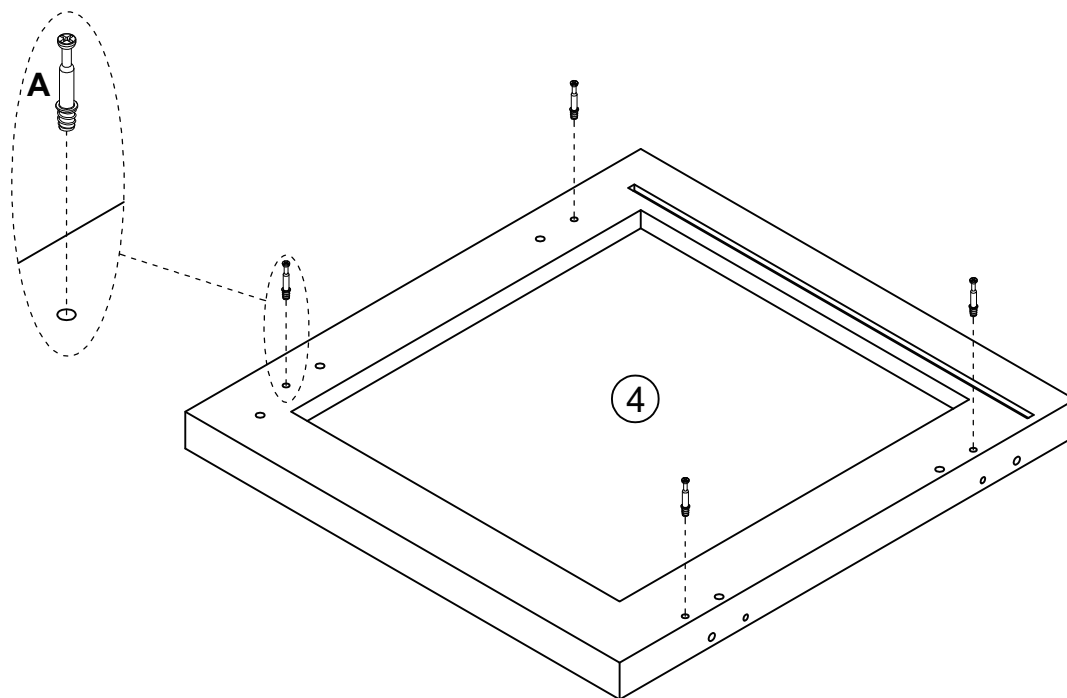



Install Cam Bolt A x4 to Part #4 as shown.

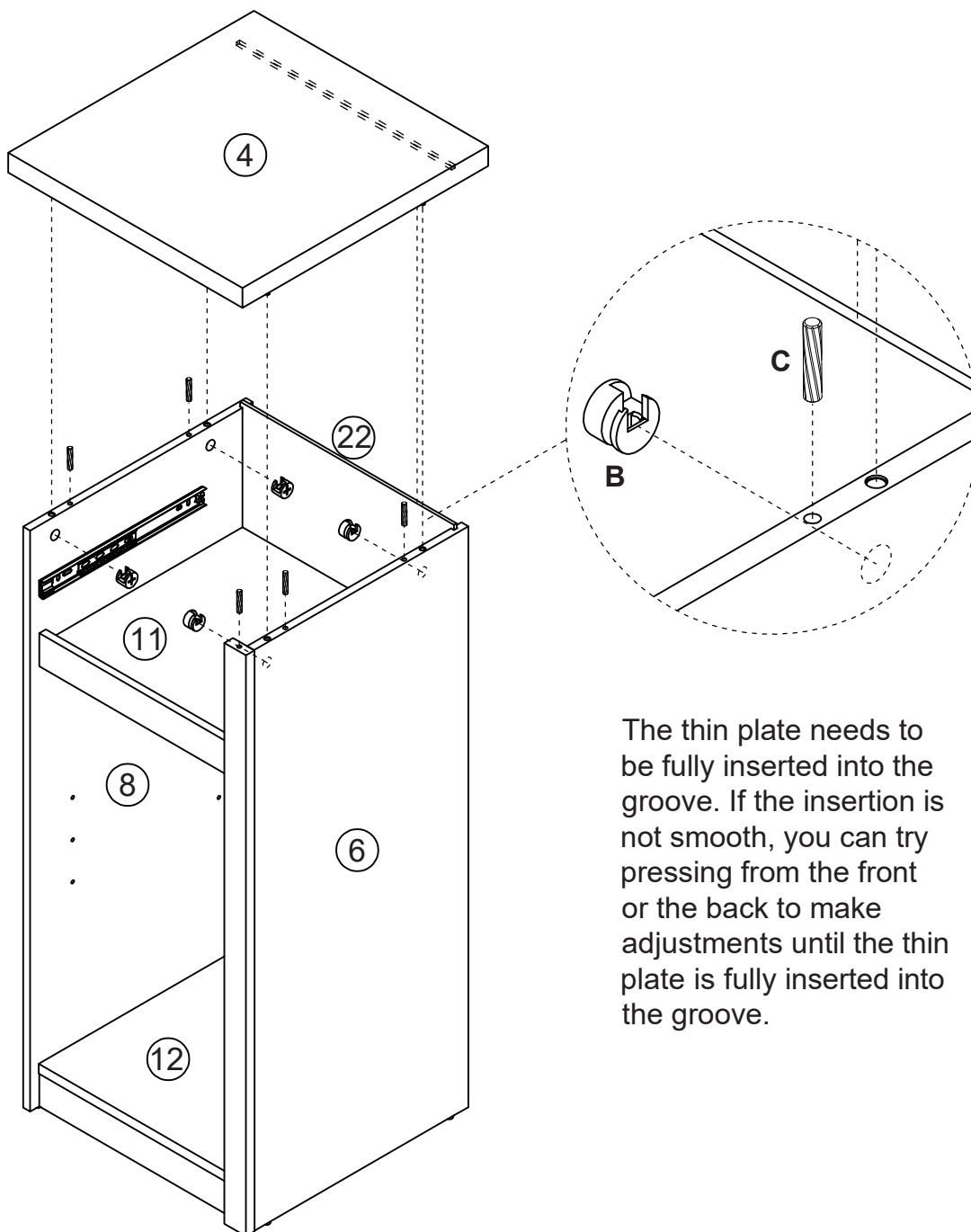



The thin plate needs to be fully inserted into the groove. If the insertion is not smooth, you can try pressing from the front or the back to make adjustments until the thin plate is fully inserted into the groove.

Attach Part #4 to the assembled unit with dowel C x5 and nuts B x4 as shown. Turn nuts B x4 to secure position.

	Bx4
	Cx5
<small>Ø6x30mm</small>	

30

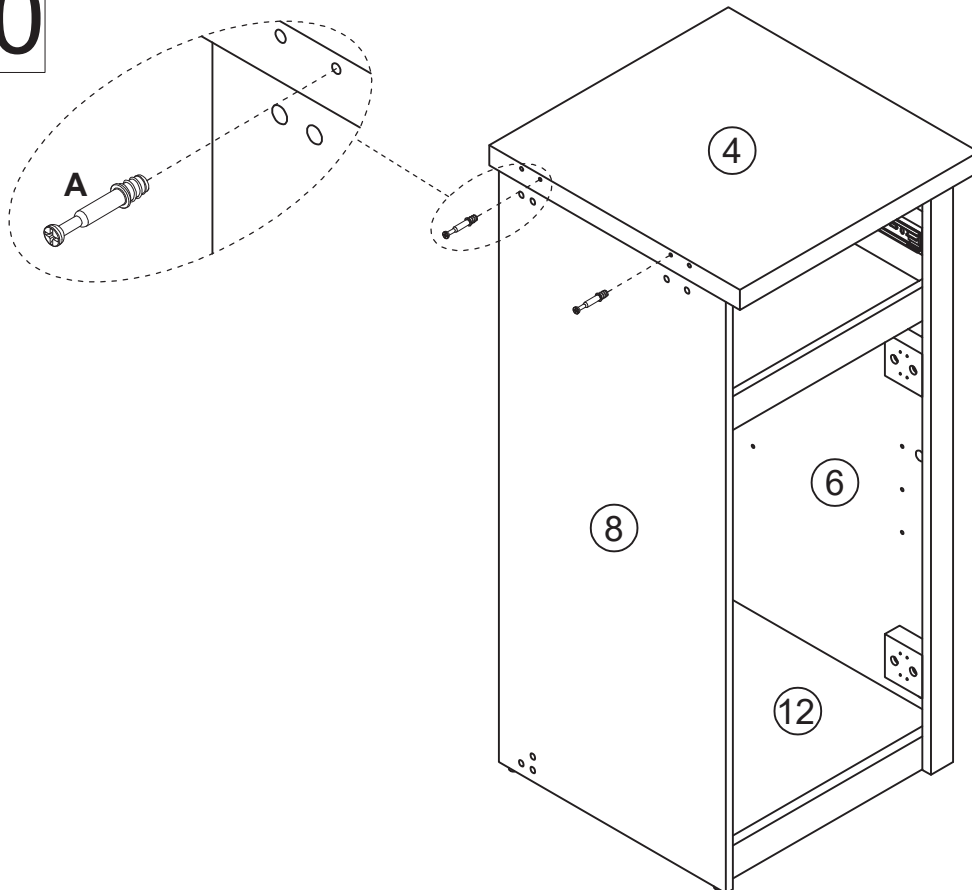

Install Cam Bolt A x2 to the assembled unit as shown.

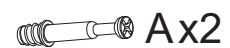

31

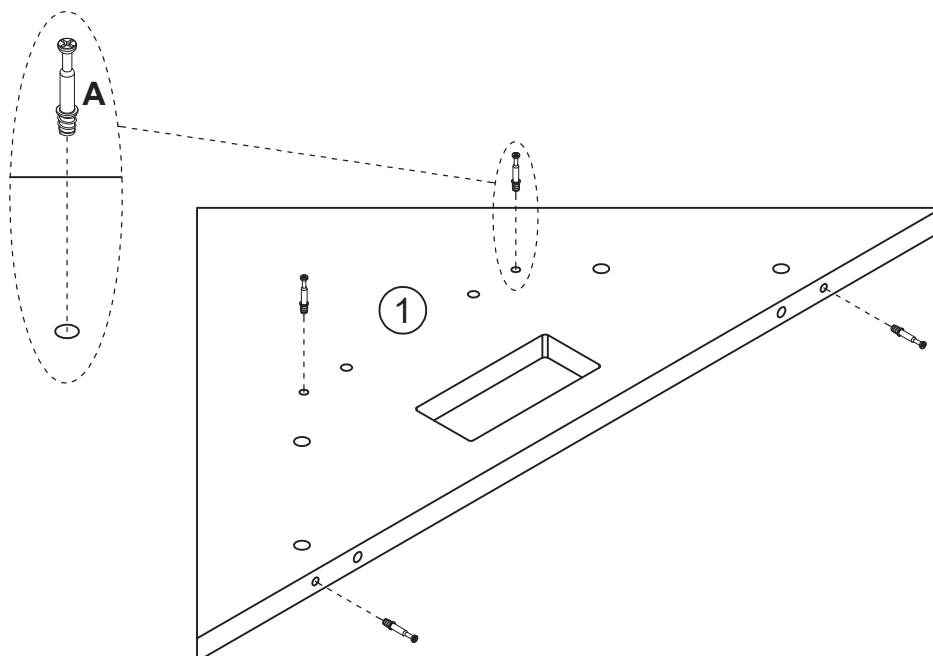



Install Cam Bolt A x4 to Part #1 as shown.

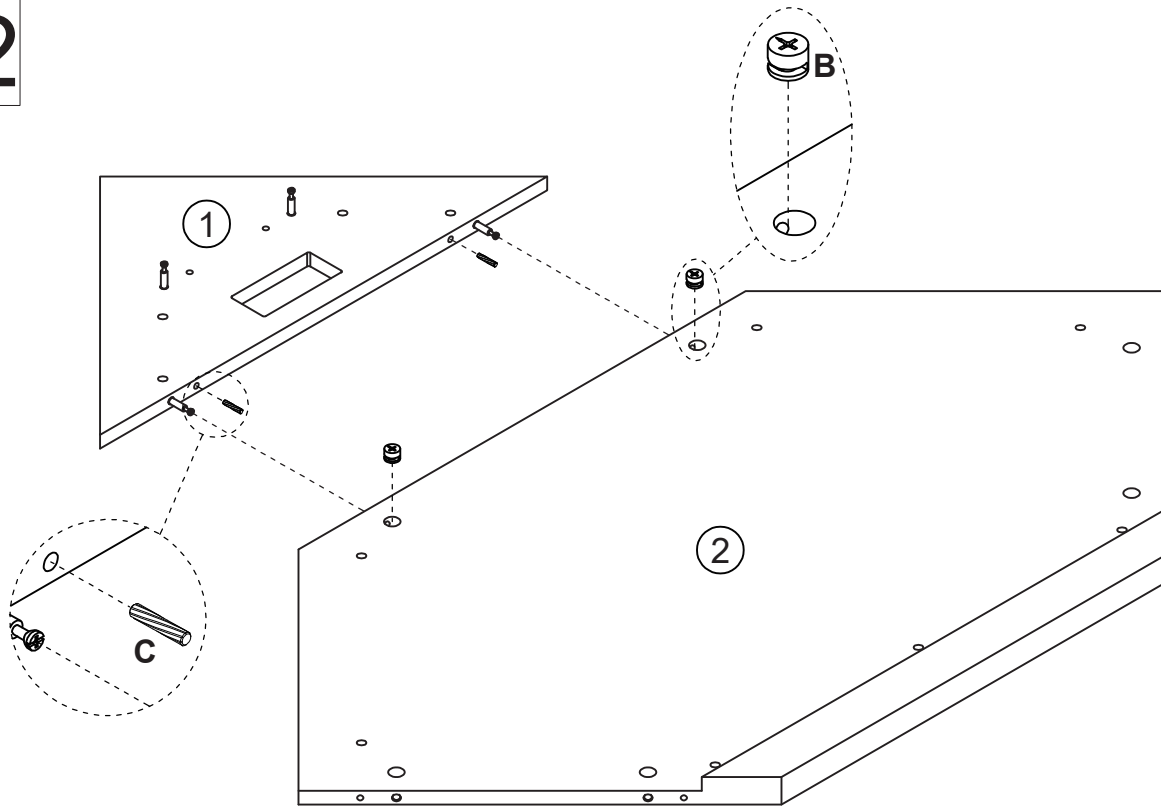

32





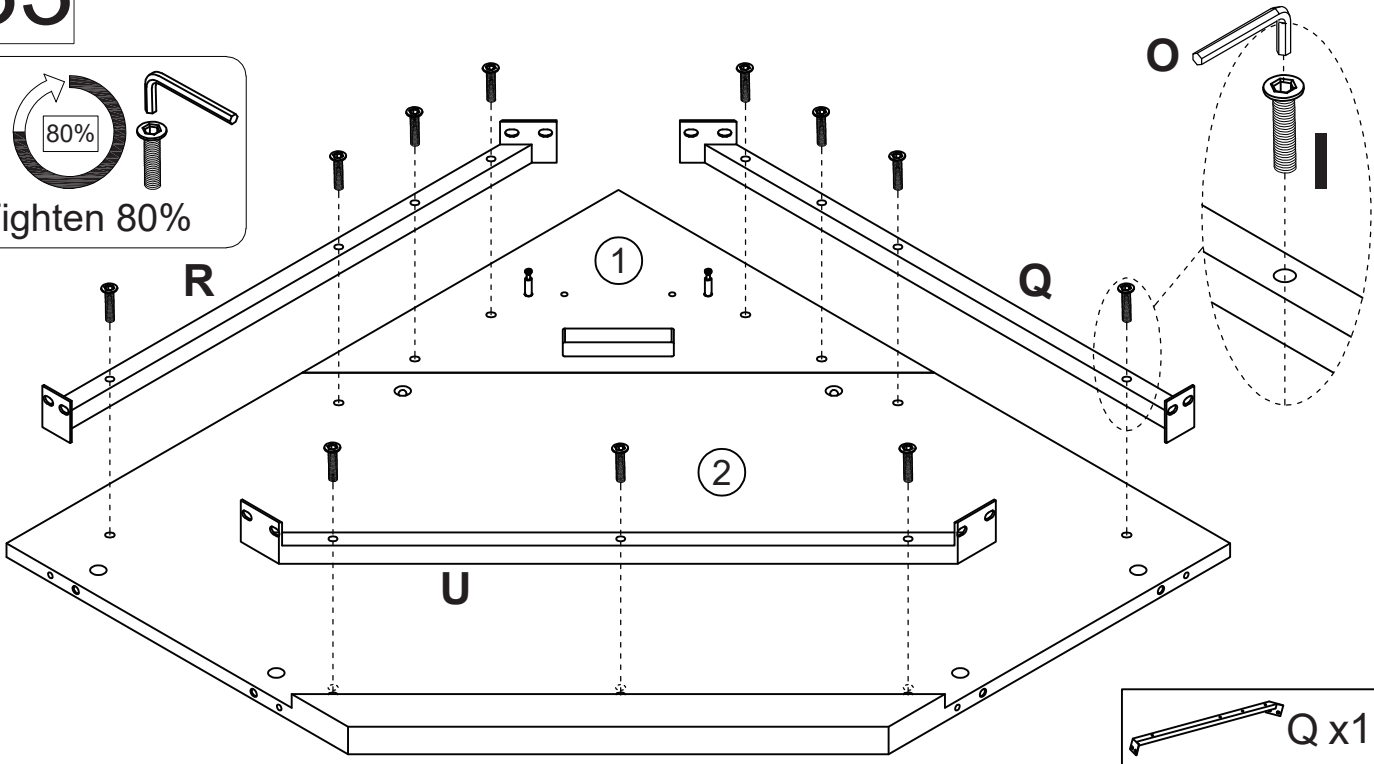
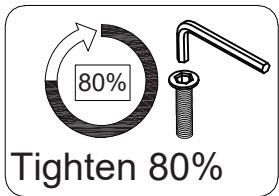

Attach Part #1 to Part #2 with dowel C x2 and nuts B x2 as shown.
Turn nuts B x2 to secure position.

	B x2
	C x2
<small>Ø6x30mm</small>	

33



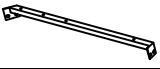

Install Q, R, U to the assembled unit with screws I x11 as shown. Then secure with tool O as shown.
Please do not lock them completely until Step 39.

	I x11		Q x1
<small>M6x28mm</small>			R x1
	O x1		U x1
<small>4mm</small>			

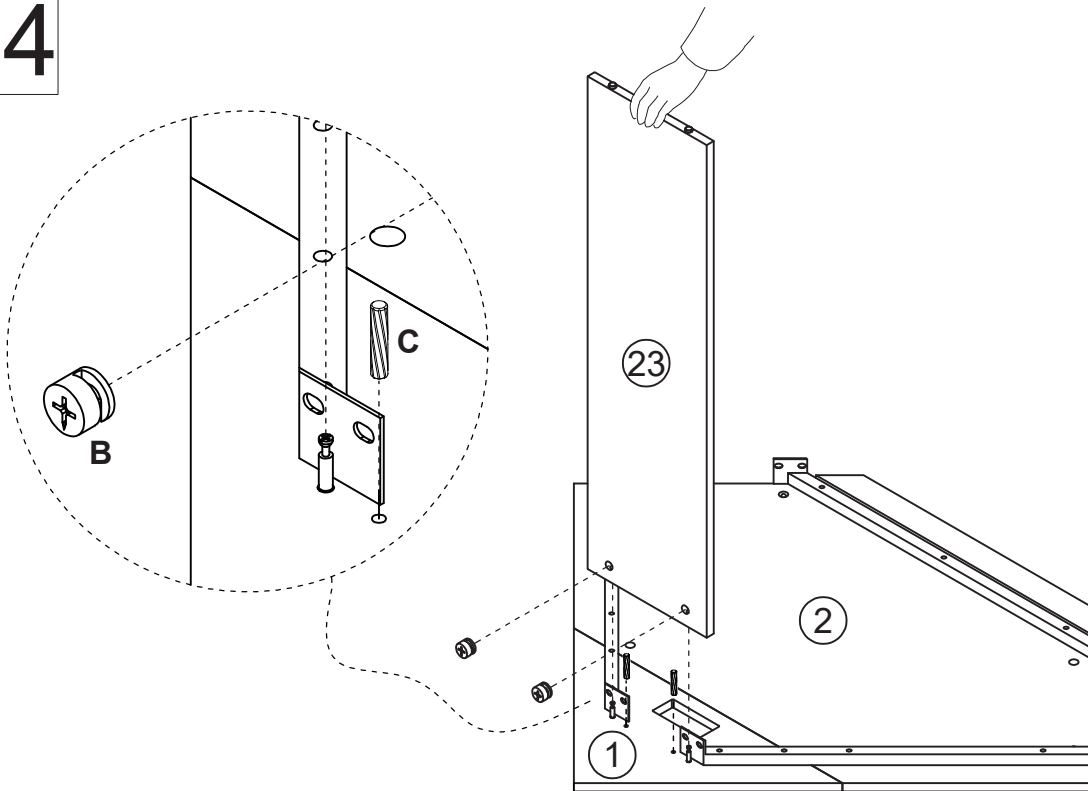
34





Attach Part #23 to Part #1 with dowel C x2 and nuts B x2 as shown.
Turn nuts B x2 to secure position.
This step and the following steps should be carried out by two adults.

	Bx2
	Cx2 Ø6x30mm

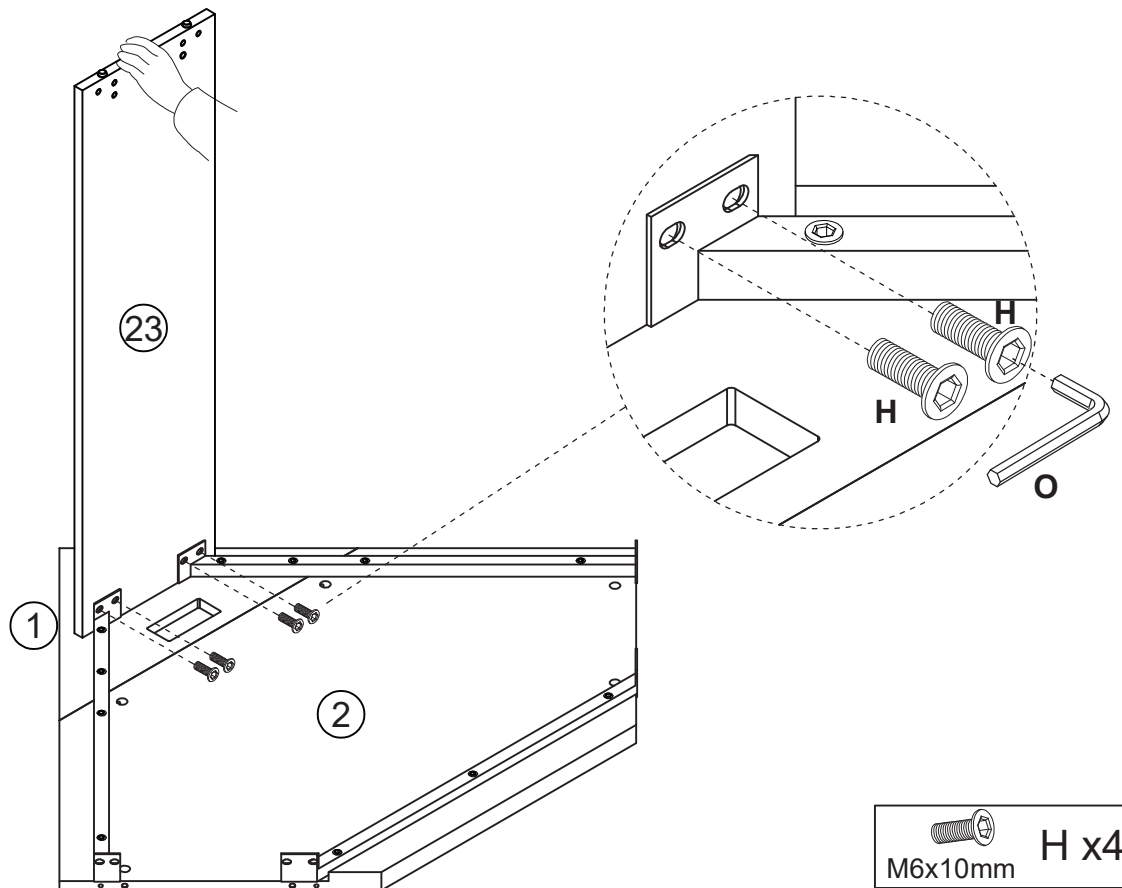
35



Secure the assembled unit with screws H x4 as shown.

	H x4 M6x10mm
	O x1 4mm

36

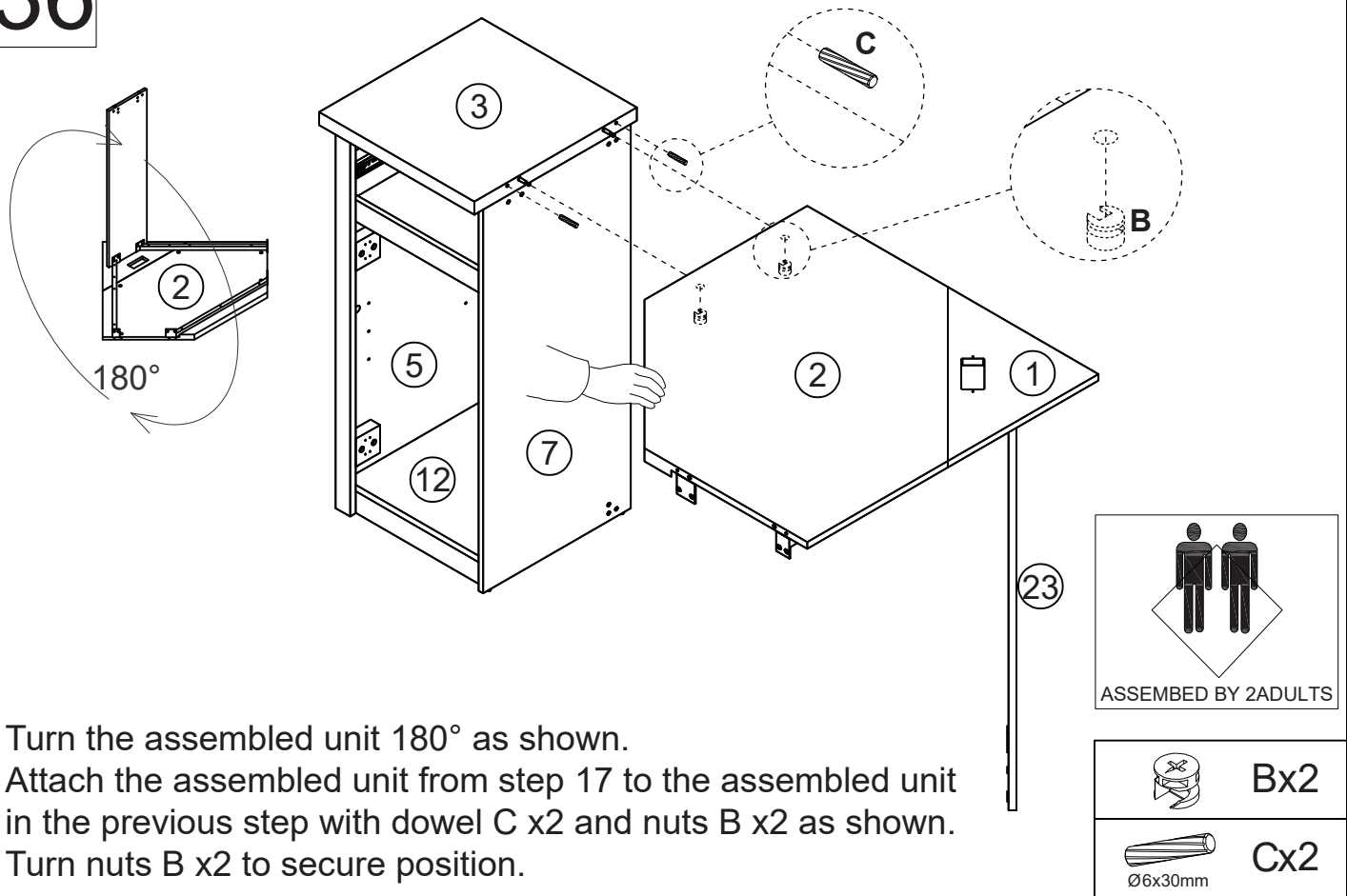

Turn the assembled unit 180° as shown.
 Attach the assembled unit from step 17 to the assembled unit in the previous step with dowel C x2 and nuts B x2 as shown.
 Turn nuts B x2 to secure position.

37

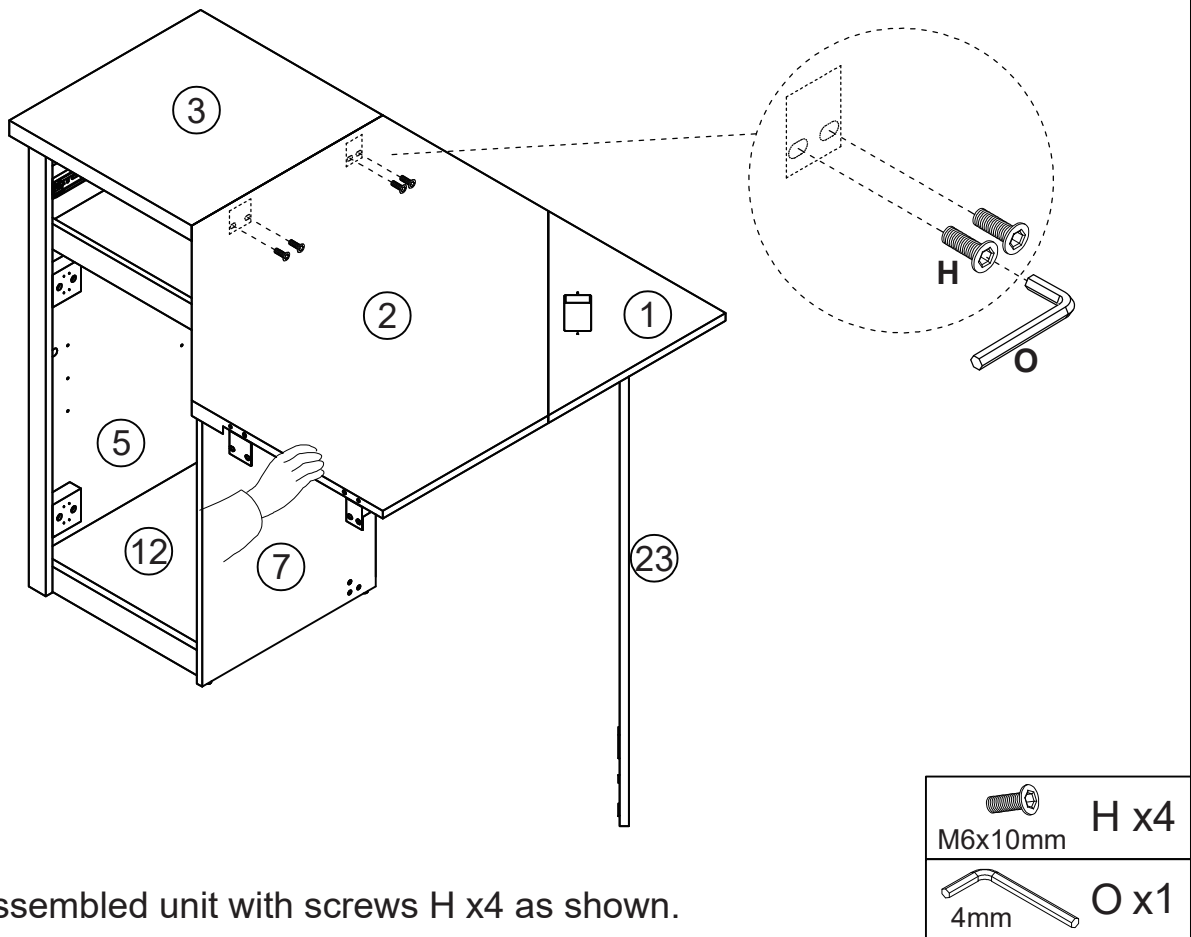

Secure the assembled unit with screws H x4 as shown.

38

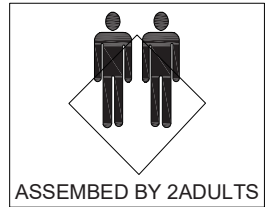
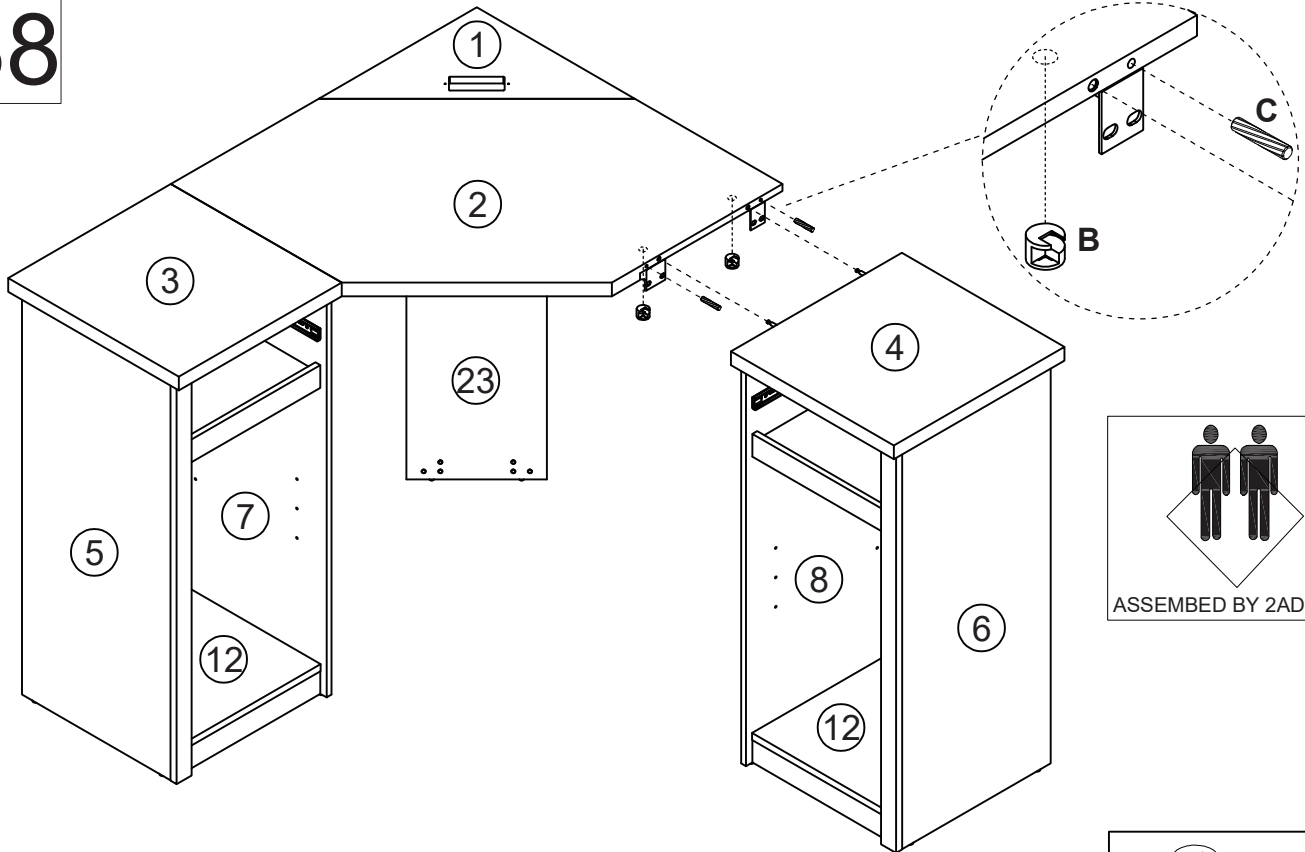

Attach the assembled unit from step 30 to the assembled unit in the previous step with dowel C x2 and nuts B x2 as shown. Turn nuts B x2 to secure position.

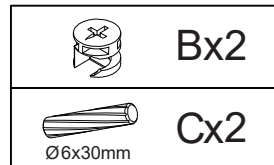

39

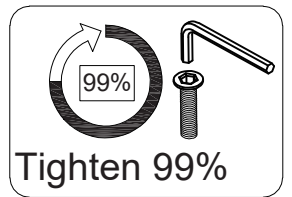
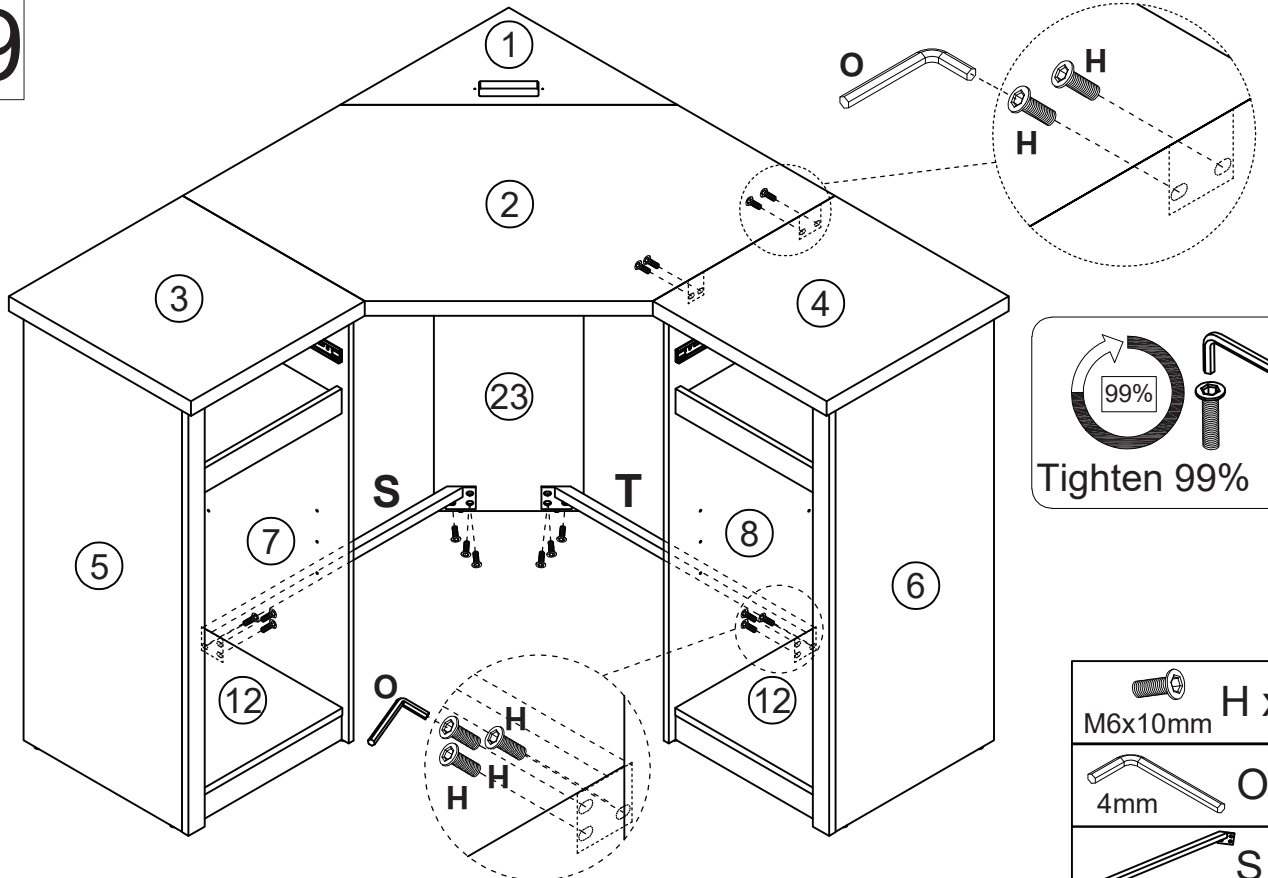

Install S and T to the assembled unit with screws H x16 as shown. Then secure with tool O as shown. Fully tighten all screws from both step 33 and step 39.

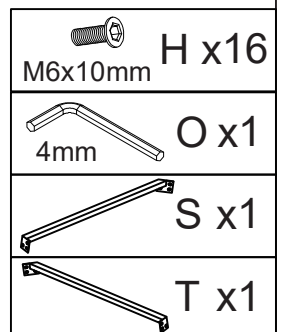

40

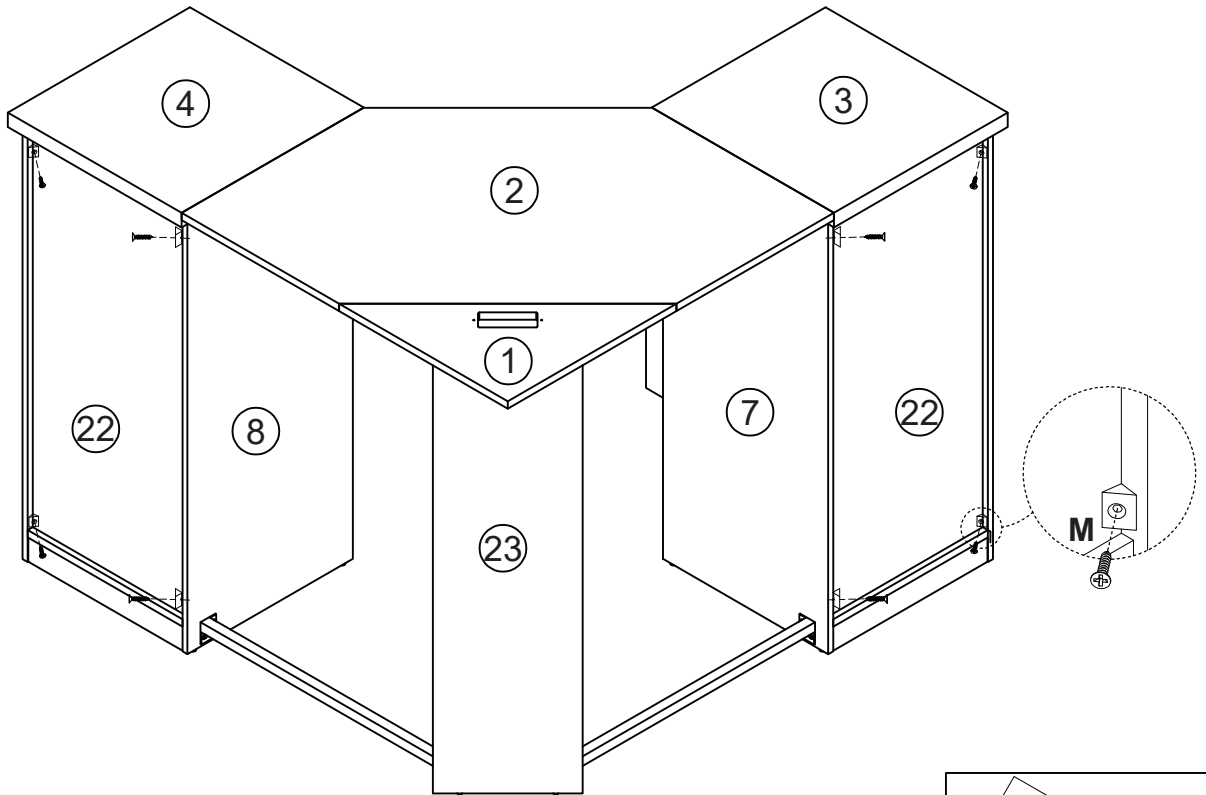

Install M x8 to the assembled unit as shown.

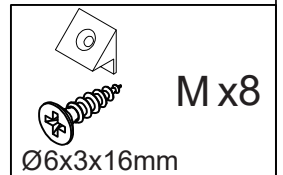

41

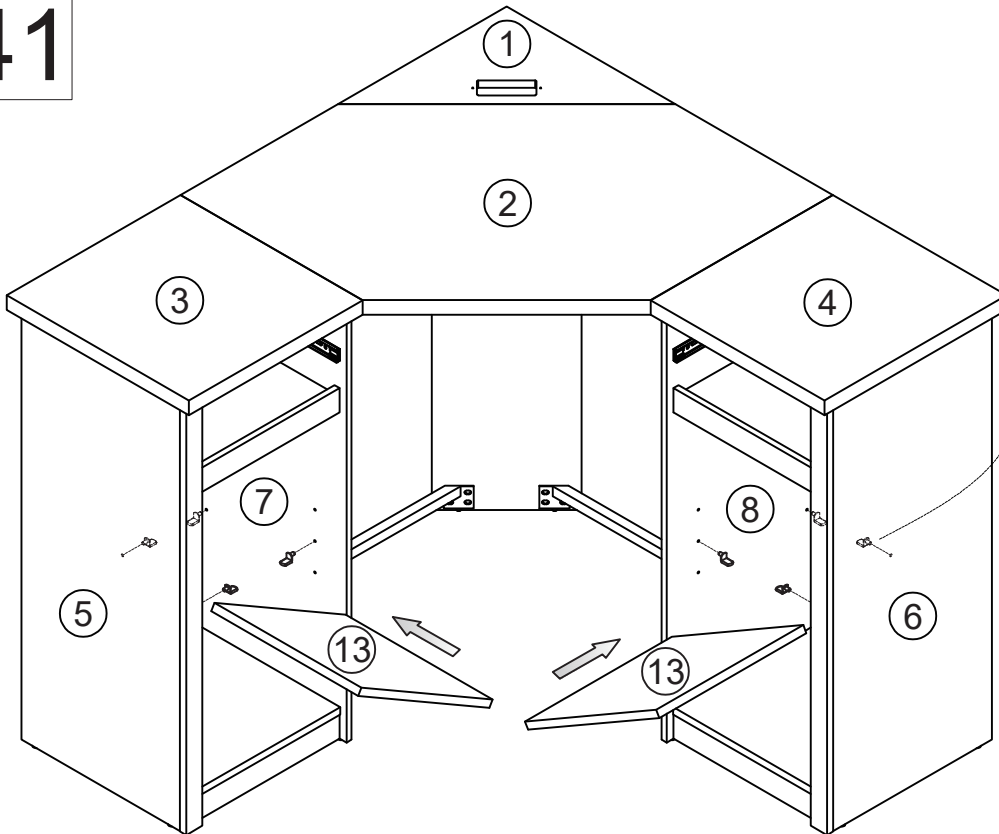

Install L x8 to the assembled unit as shown.
Then put Part #13 on L as shown.

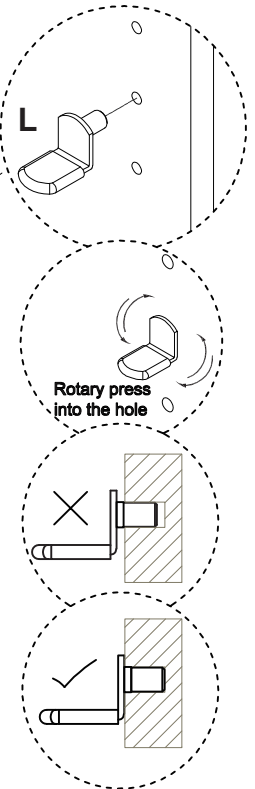

42

X 2

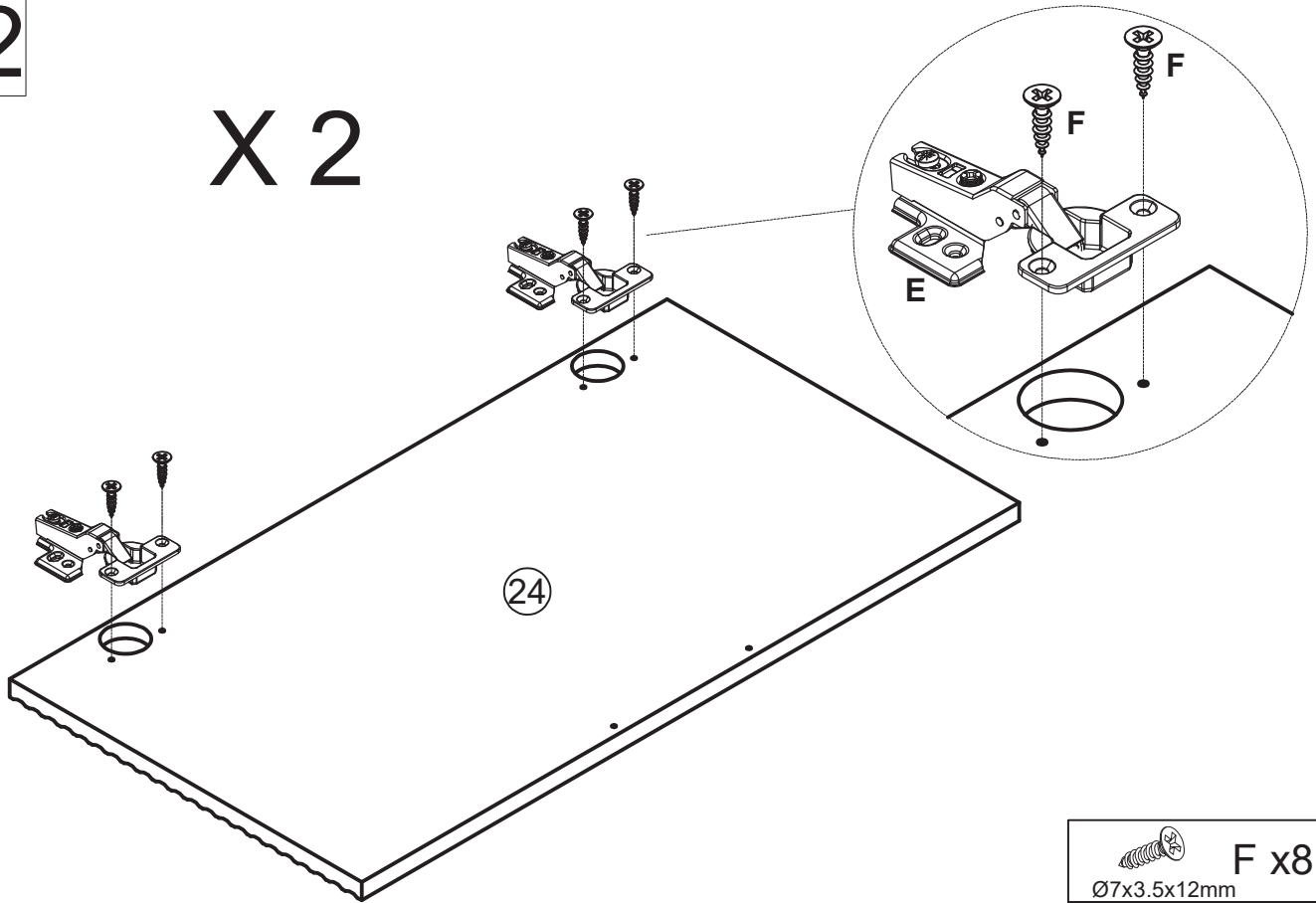

Install hinge E x4 to Part #24 x2 with screws F x8 as shown.

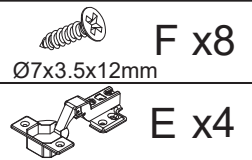

43

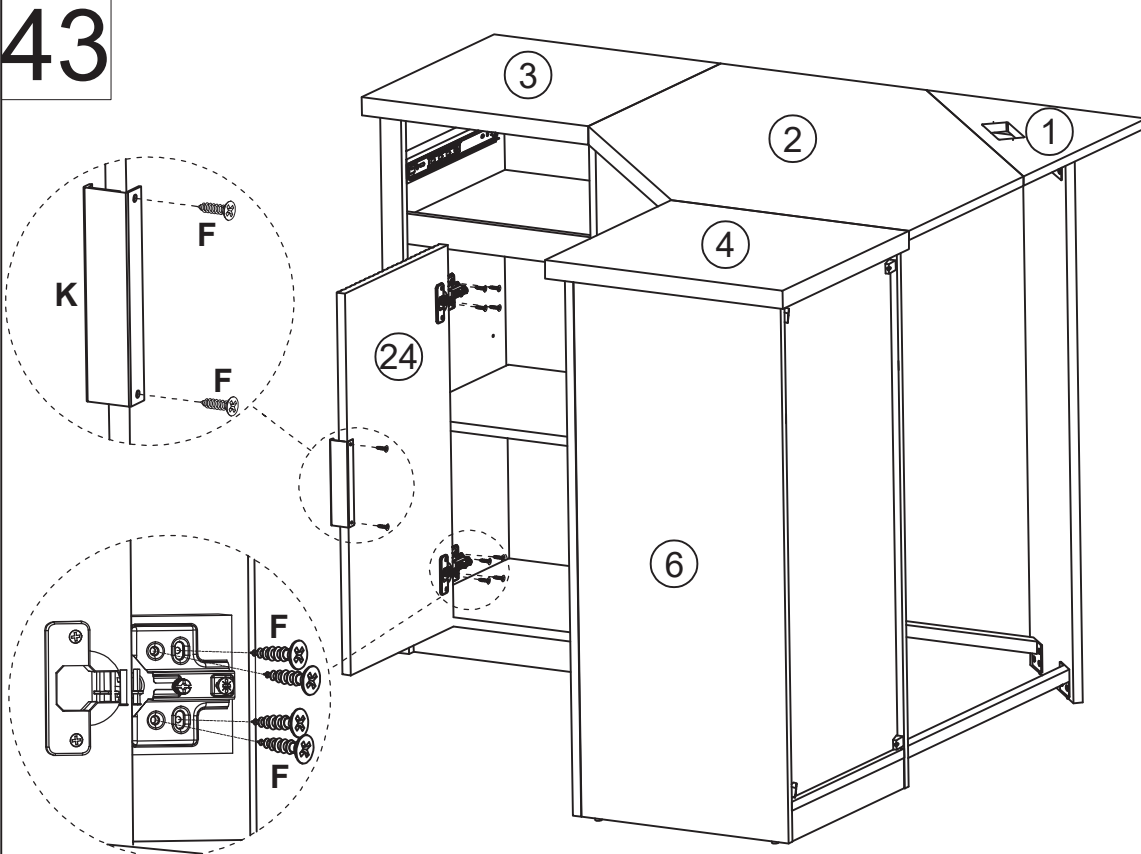

Attach Part #24 to the assembled unit with screws F x8 as shown.
Install handle K to Part #24 with screws F x2 as shown.

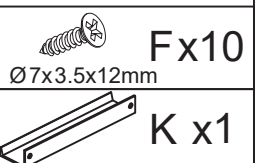
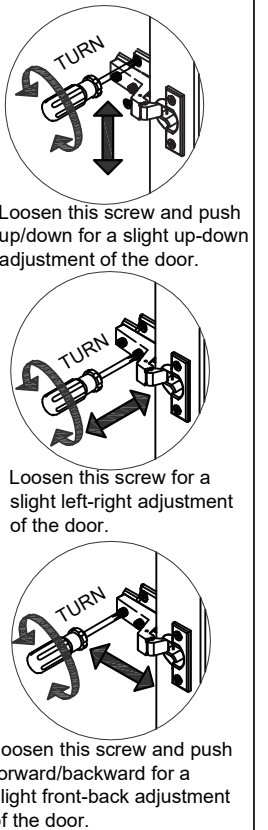

44

Attach Part #24 to the assembled unit with screws F x8 as shown. Install handle K to Part #24 with screws F x2 as shown.

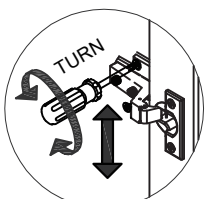

Loosen this screw and push up/down for a slight up-down adjustment of the door.

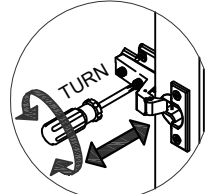

Loosen this screw for a slight left-right adjustment of the door.

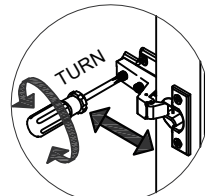

Loosen this screw and push forward/backward for a slight front-back adjustment of the door.

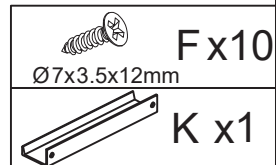
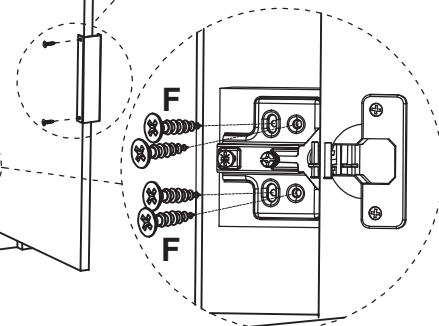
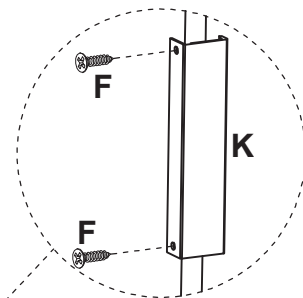
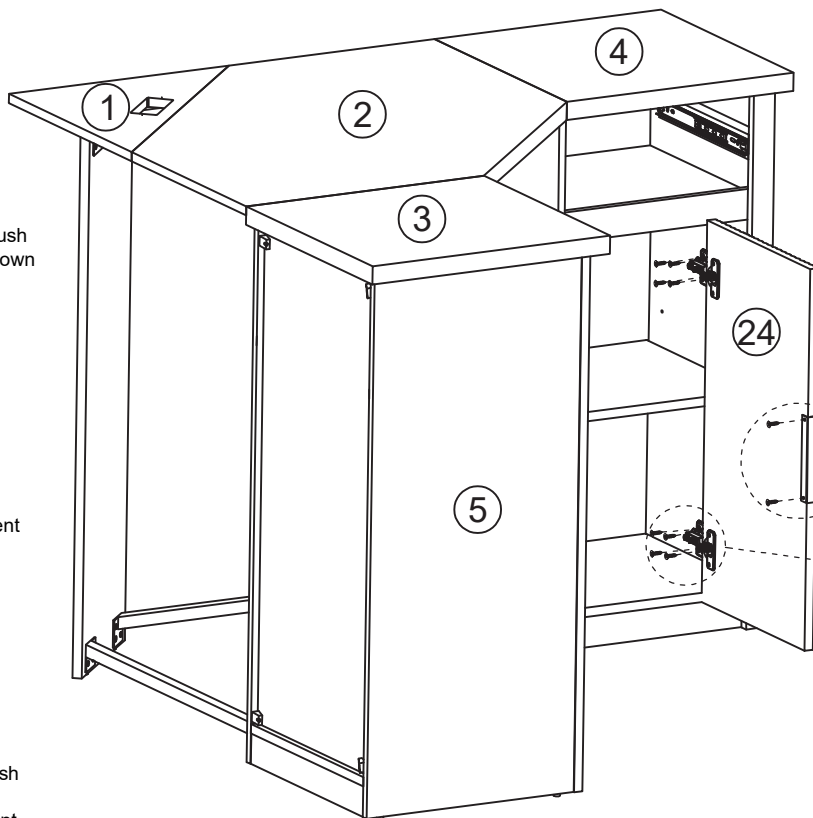

45

X 2

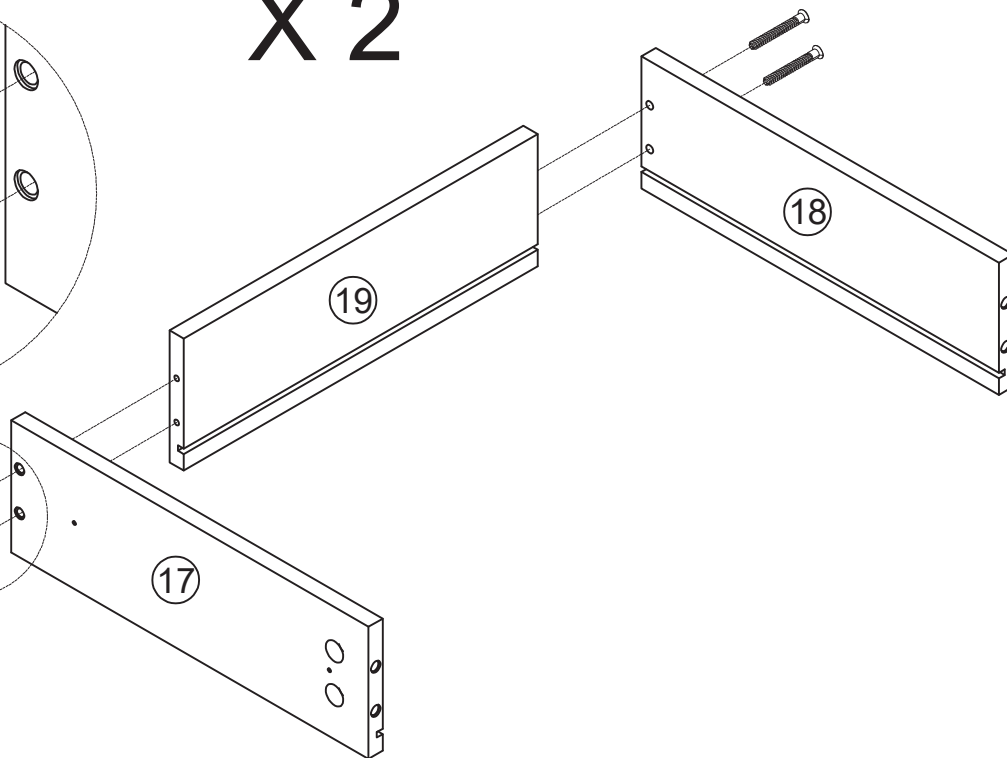
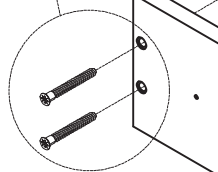
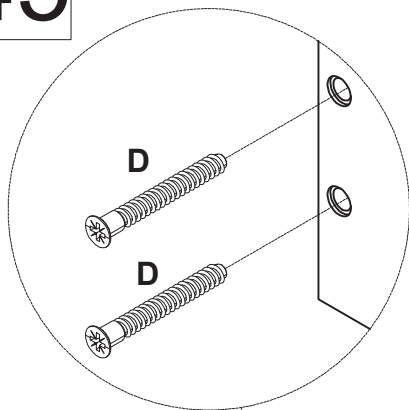

Attach Part #17 x2 and Part #18 x2 to Part #19 x2 with screws D x8 as shown.

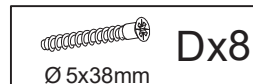

46

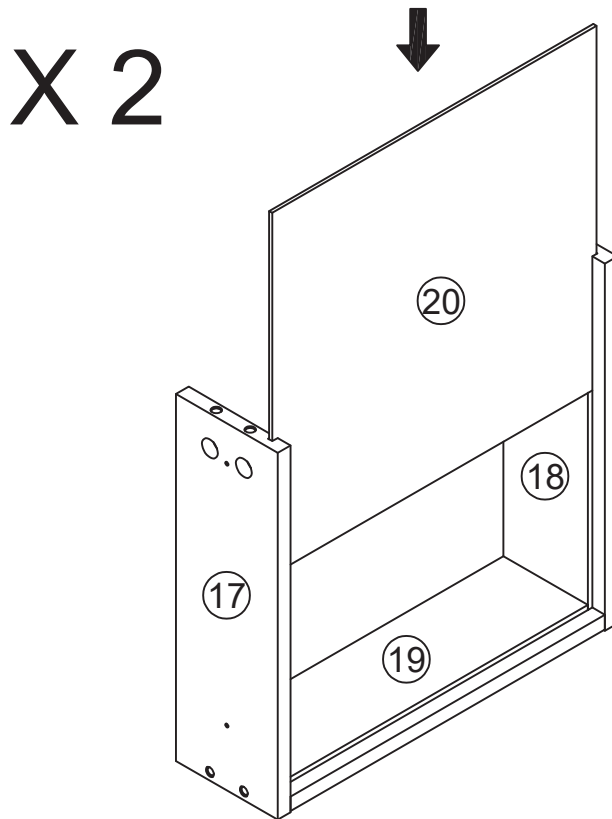

The thin plate needs to be fully inserted into the groove. If the insertion is not smooth, you can try pressing from the front or the back to make adjustments until the thin plate is fully inserted into the groove.

Insert Part #20 x2 straight down into the grooves of the assembled unit x2 in the previous step as shown.

47

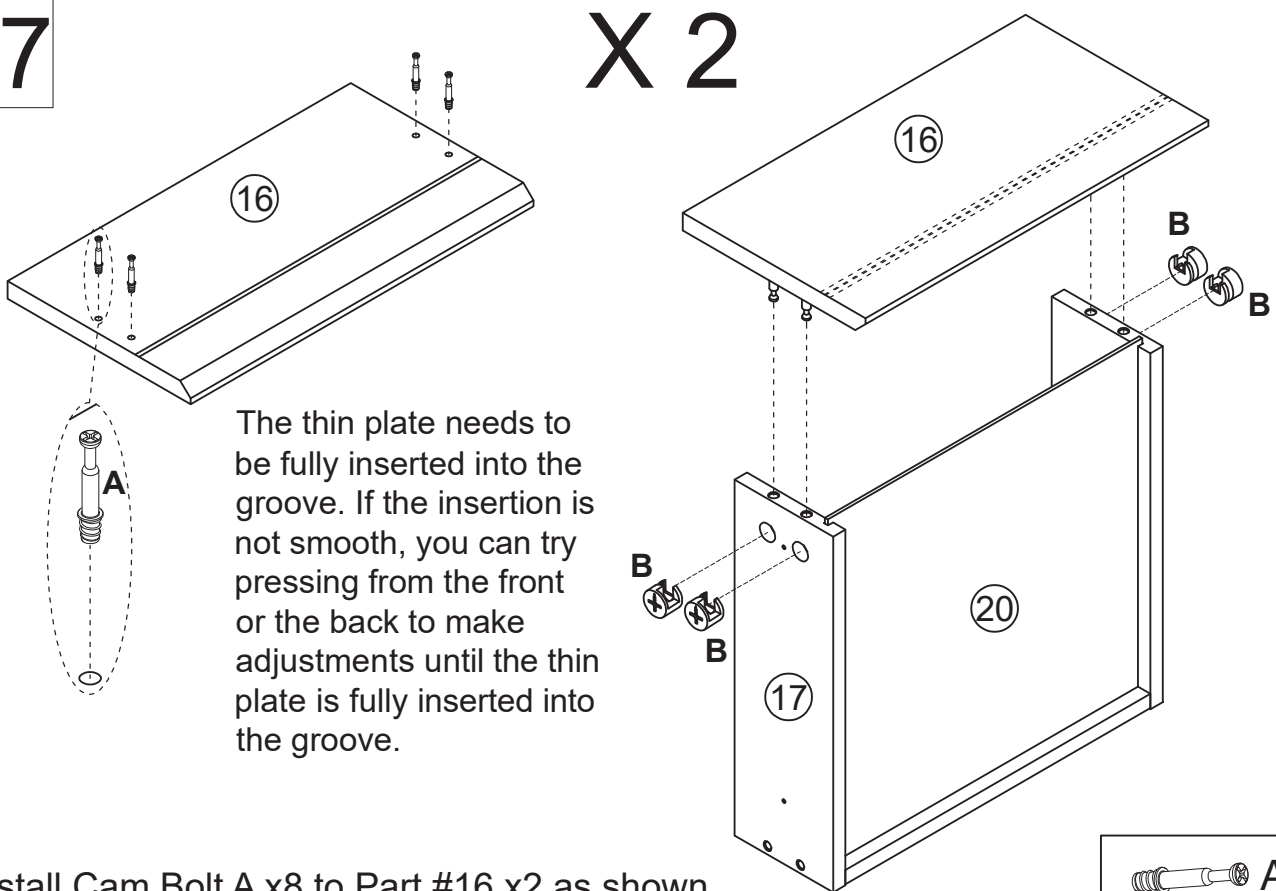

The thin plate needs to be fully inserted into the groove. If the insertion is not smooth, you can try pressing from the front or the back to make adjustments until the thin plate is fully inserted into the groove.

Install Cam Bolt A x8 to Part #16 x2 as shown. Then attach Part #16 x2 to the assembled unit x2 from the step 46 with nuts B x8 as shown. Turn nuts B x8 to secure position.

 Ax8

 Bx8

48

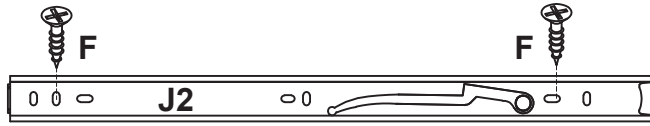

X 2

Attention: The installation direction of the track is divided into front and back.

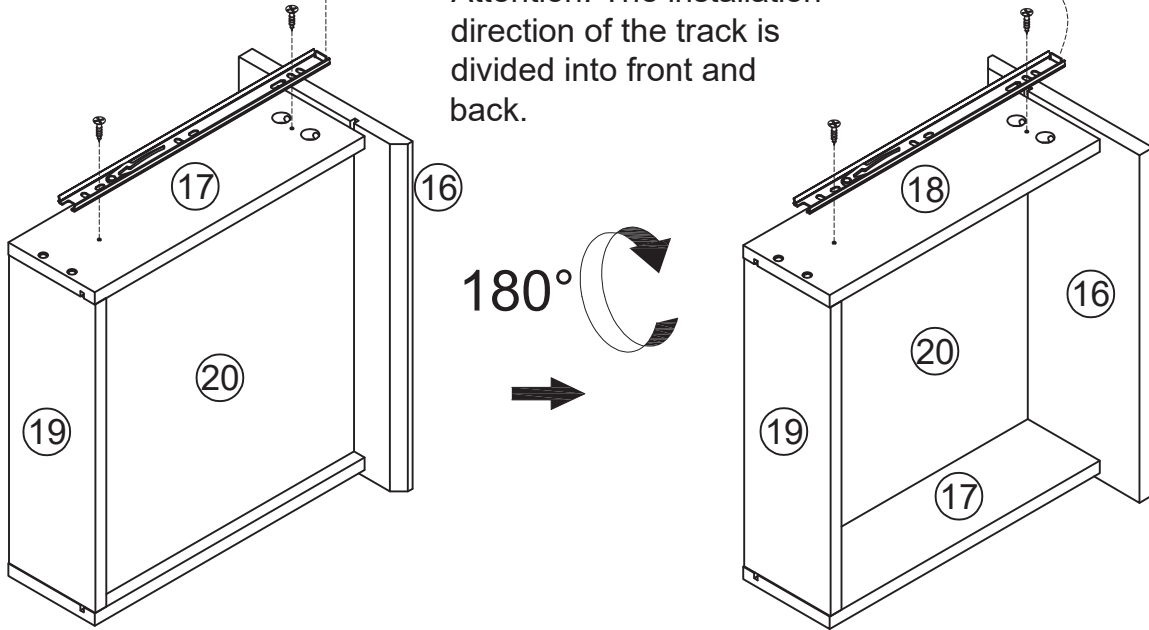

Install the inner rail J2 x4 to the assembled unit x2 in the previous step with screws F x8 as shown.

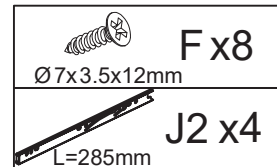

49

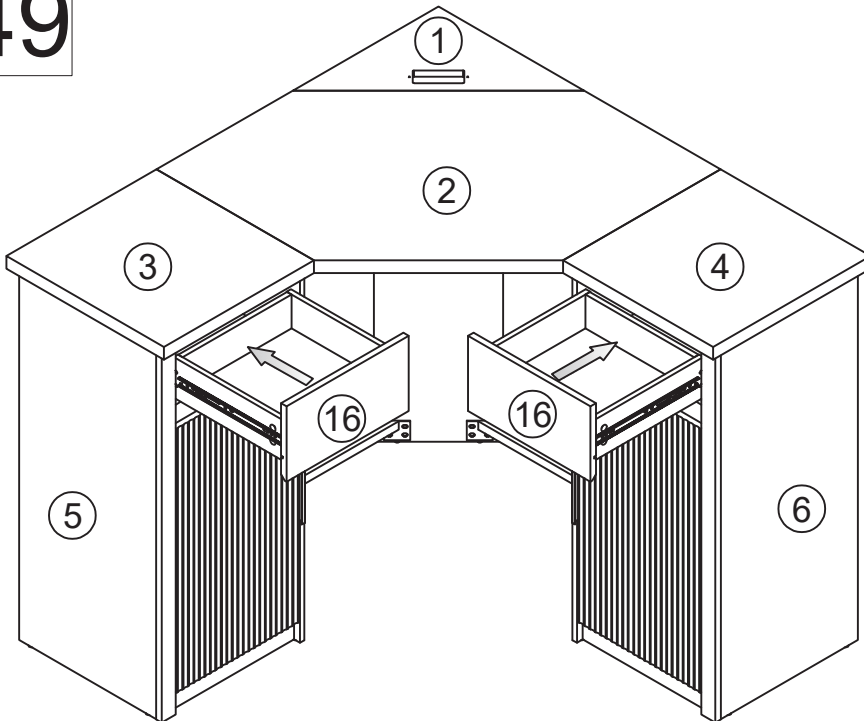

Insert the inner rail J2 into the outer rail J1 with screws F x4 as shown.

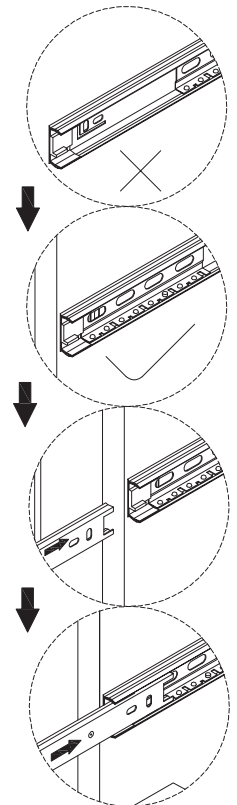

This screw can be loosened to adjust the top and bottom gaps of the drawer

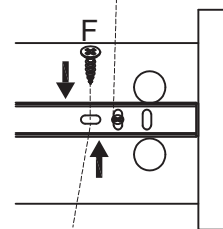

Lock screw (F) after adjusting the upper and lower gaps



50

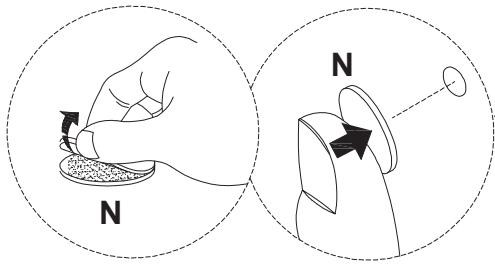

Cover the visible hole with a cap

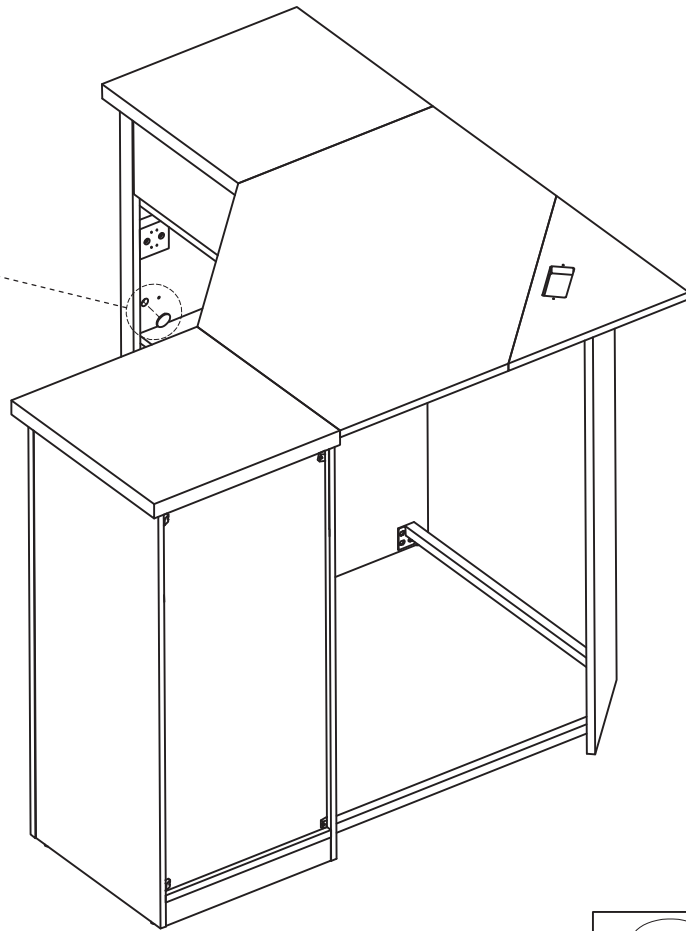

We provide round stickers N x22.
You can stick it to cover the nuts so as to look nicer.



51

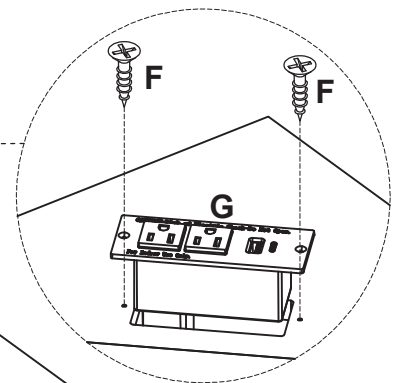
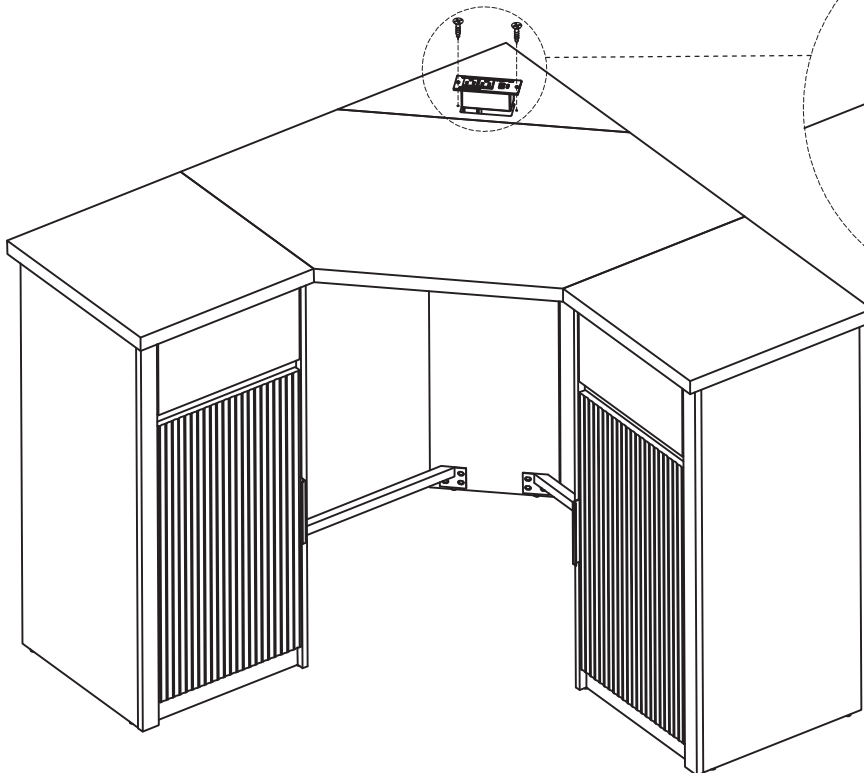

Install G with screws F x2 as shown.



Enjoy the Unit

