

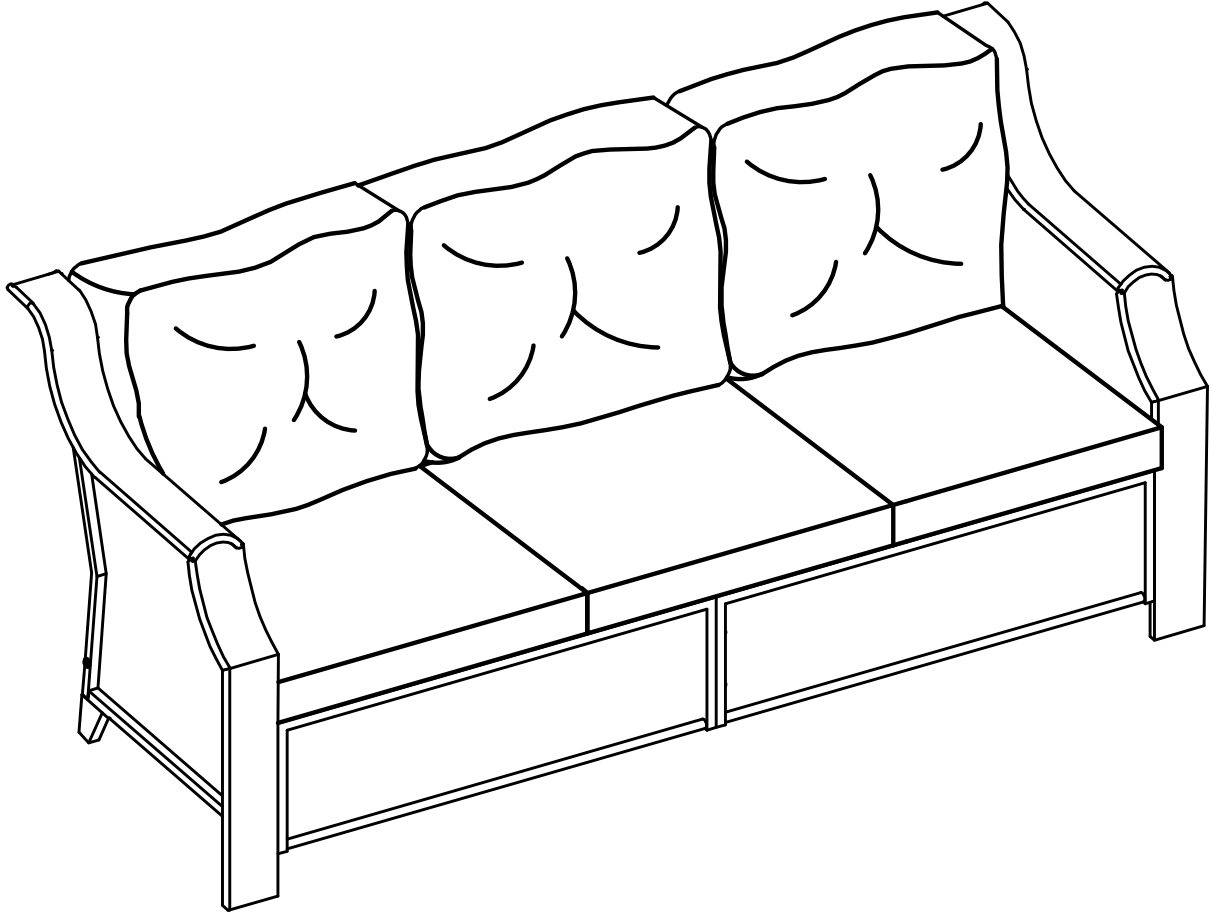











Assembly Instructions

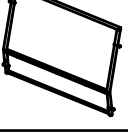

***Don't fully tighten all the bolts till the very end!**

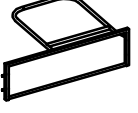
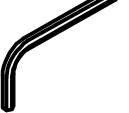

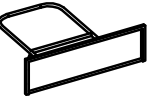
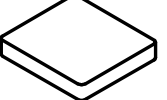
PRE-ASSEMBLY PREPARATION:

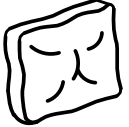
- Please read through the instructions before beginning assembly.
- Clear out the space for assembly and lay out all of the parts based on the Parts List, extra room will allow you to easily determine if all the pieces are present.
- Keep small parts and pieces away from children until fully assembled.

Part no.	Part	QTY	Image	Part no.	Part	QTY	Image
A1	Left arm	1		H	Bolt (M6*15mm)	12	
A2	Right arm	1		I	Bolt (M6*20mm)	8	
B	Back	1		J	Bolt (M6*35mm)	4	
C	Back	1		K	Washer	1	
D	Seat	1		L	Allen Wrench	1	
E	Seat	1		M	Washer	1	
F	Seat	1		N	Seat Cushion	3	
G	Middle leg	1		O	Back Cushion	3	

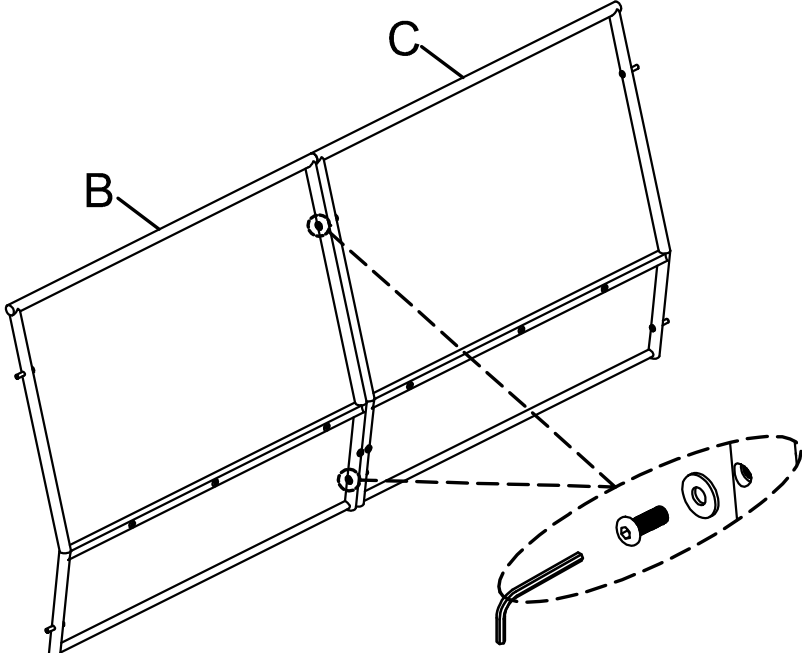

Step 1: Attach left back B to right back C with 2pcs bolts I and 2pcs washers K , using Allen wrench L .Note:Don't fully tighten the bolts.

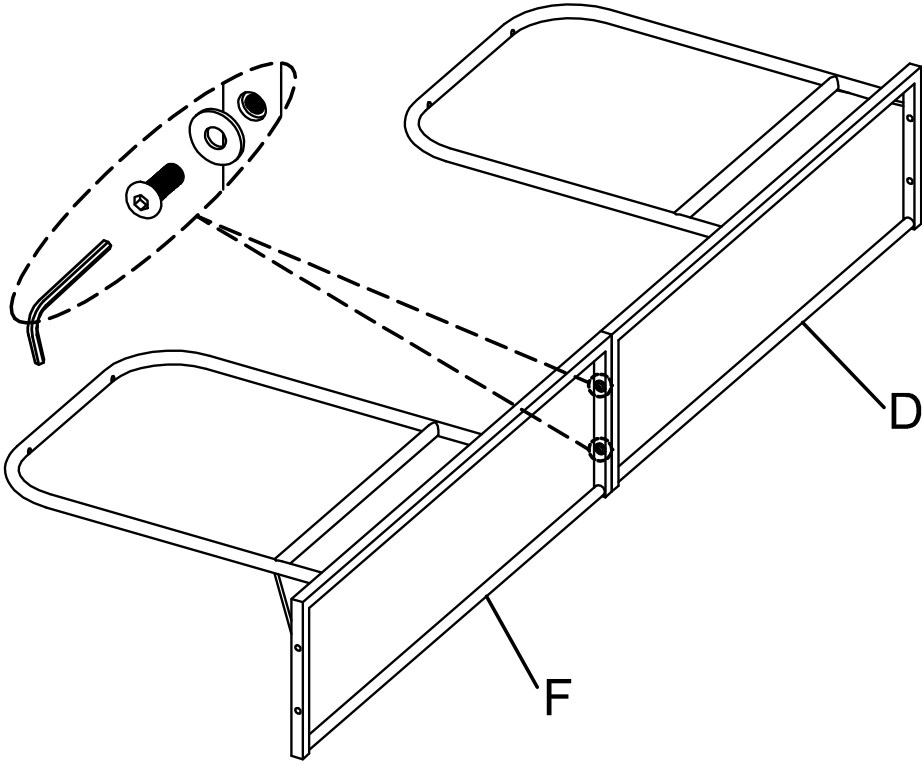

	L
	I x2
	K x2

Step 2: Attach left seat F to right D with 2pcs bolts H and 2pcs washers K ,using Allen wrench L .Note: Don't fully tighten the bolts.

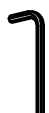

	L
	H x2
	K x2

Step 3: Attach right A1 to back C with 2pcs bolts H and 2pcs washers K, using Allen wrench L. Note: Don't fully tighten all the bolts.

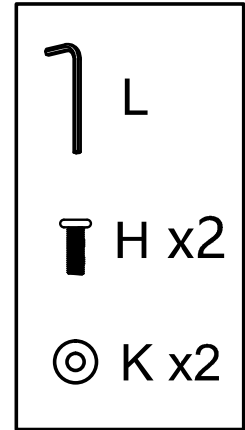
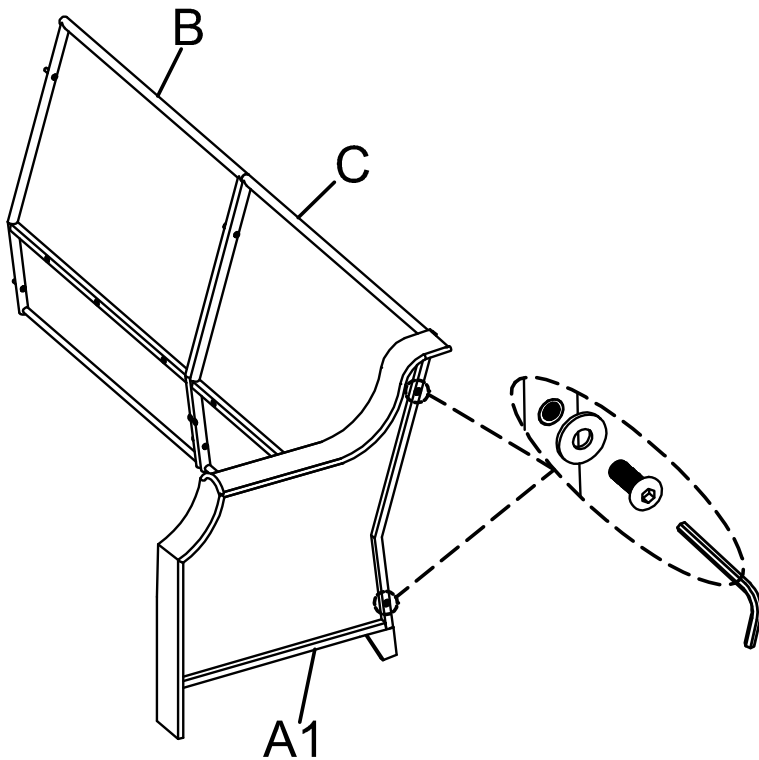

Step 4: Attach left arm A2 to back B with 2pcs bolts H and 2pcs washers K, using Allen wrench L. Note: Don't fully tighten all the bolts.

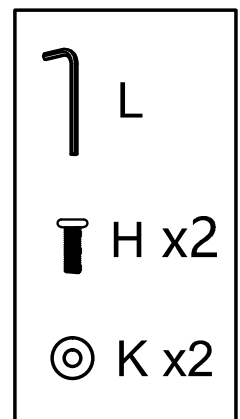
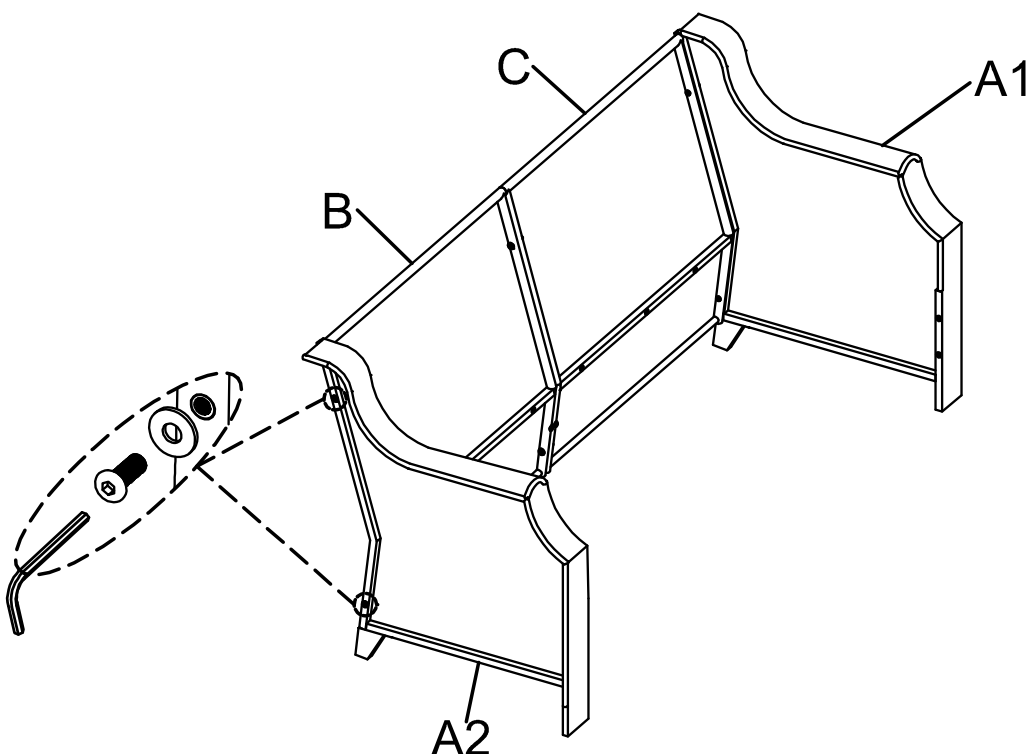

Step 5: Attach seat D&F to arms A1&A2 with 4pcs bolts J and 4pcs washer K, using Allen wrench L. Note: Don't fully tighten all the bolts.

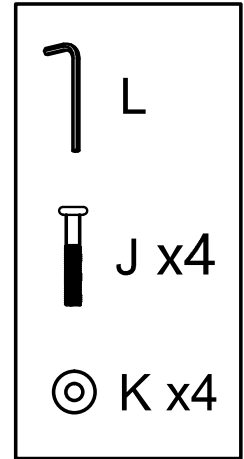
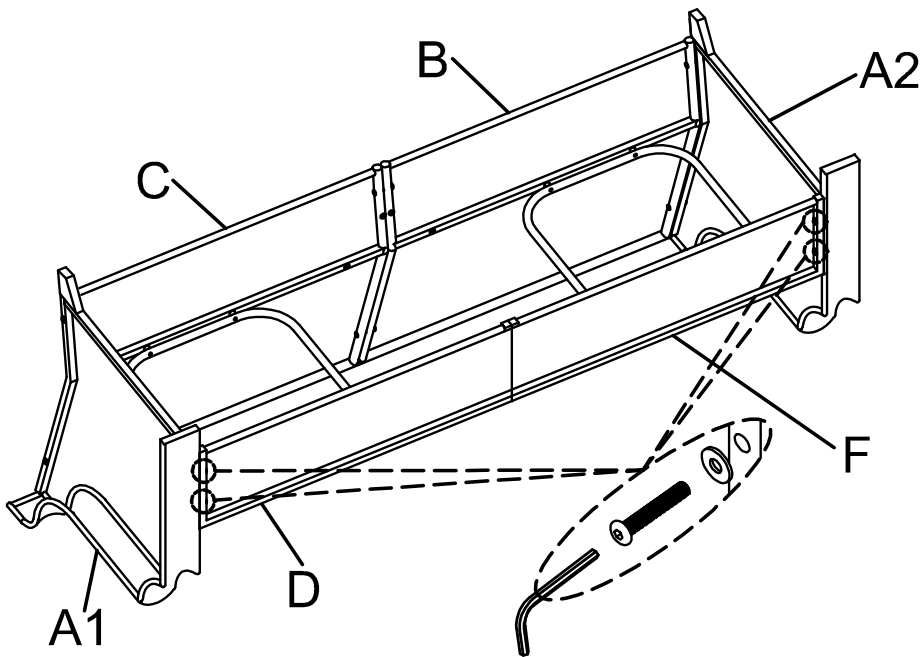

Step 6: Attach middle leg G to back with 2pcs bolt J, 1pc washer M and 2pcs washer K, using Allen wrench L.

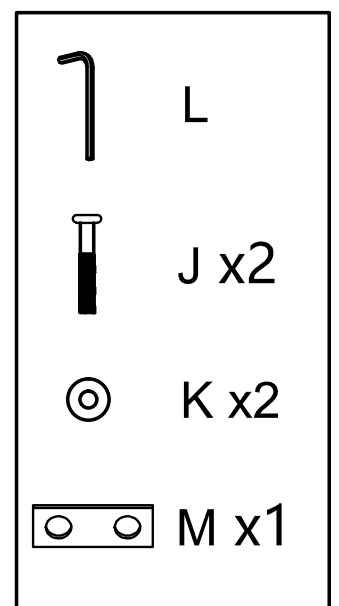
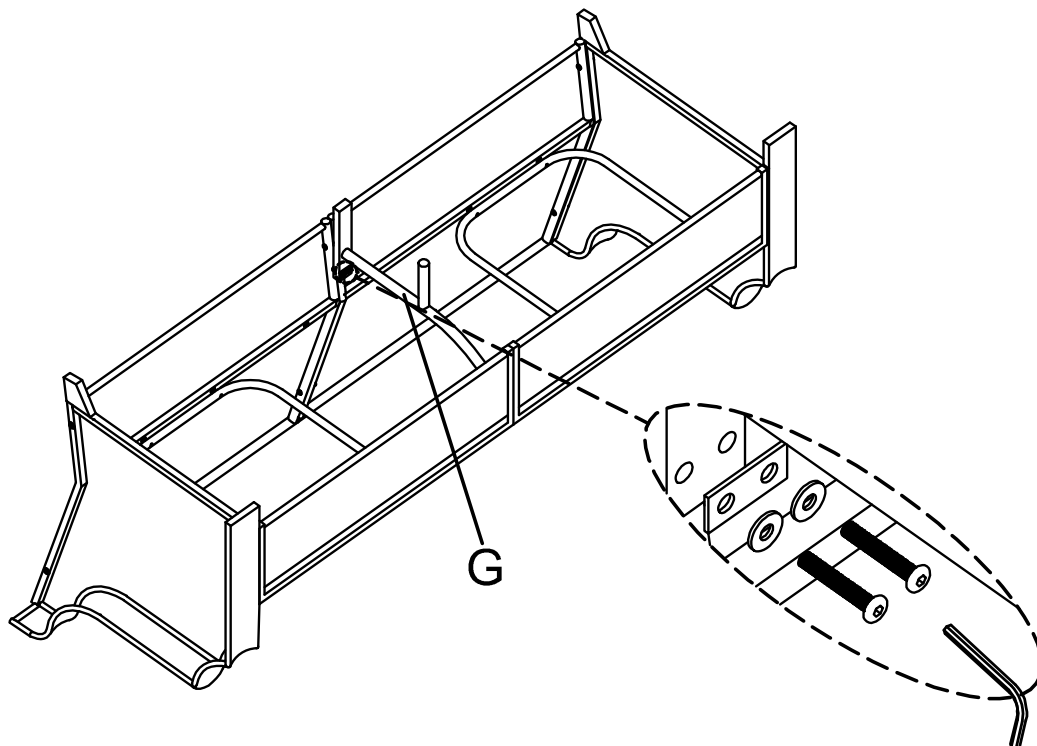

Step 7: Attach middle seat E to middle leg G with 2pcs bolts I and 2pcs washer K. using Allen wrench L.

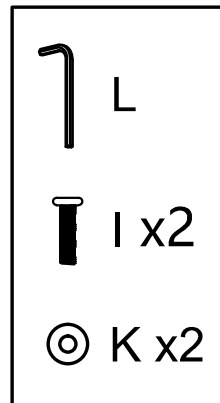
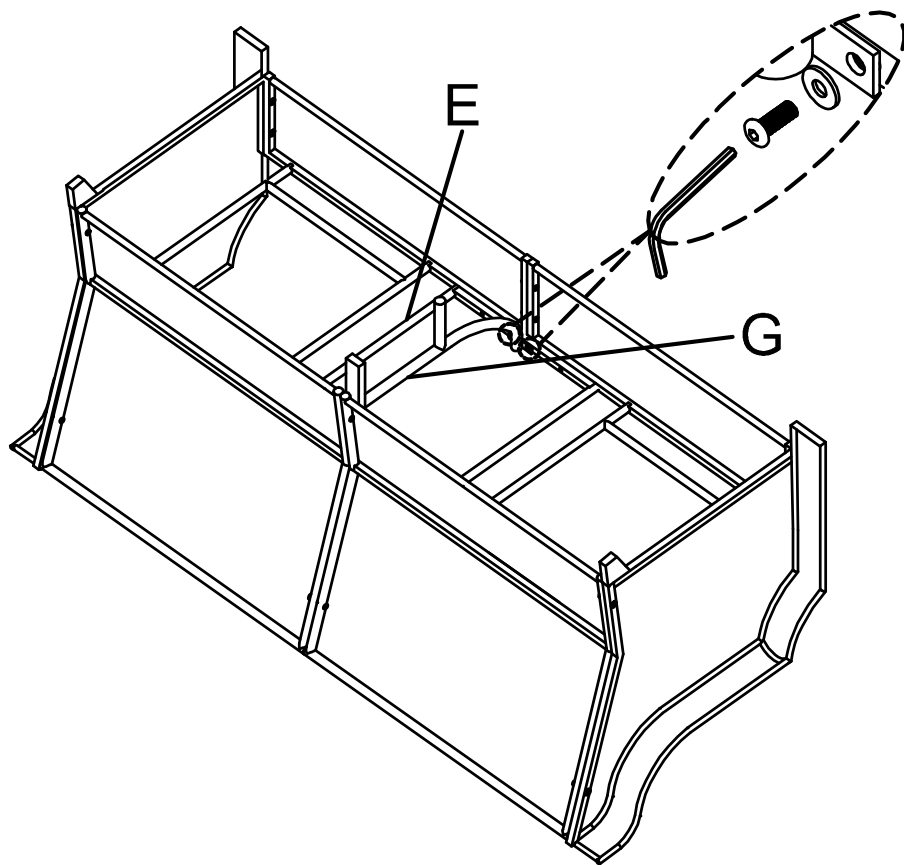

Step 8: Attach middle seat E to seat F&D with 2pcs bolts J and 2pcs washer K. using Allen wrench L.

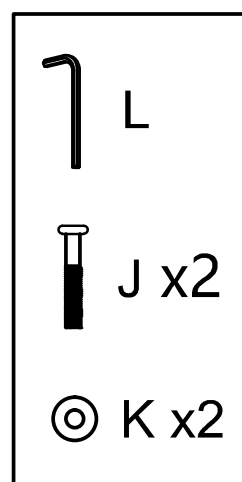
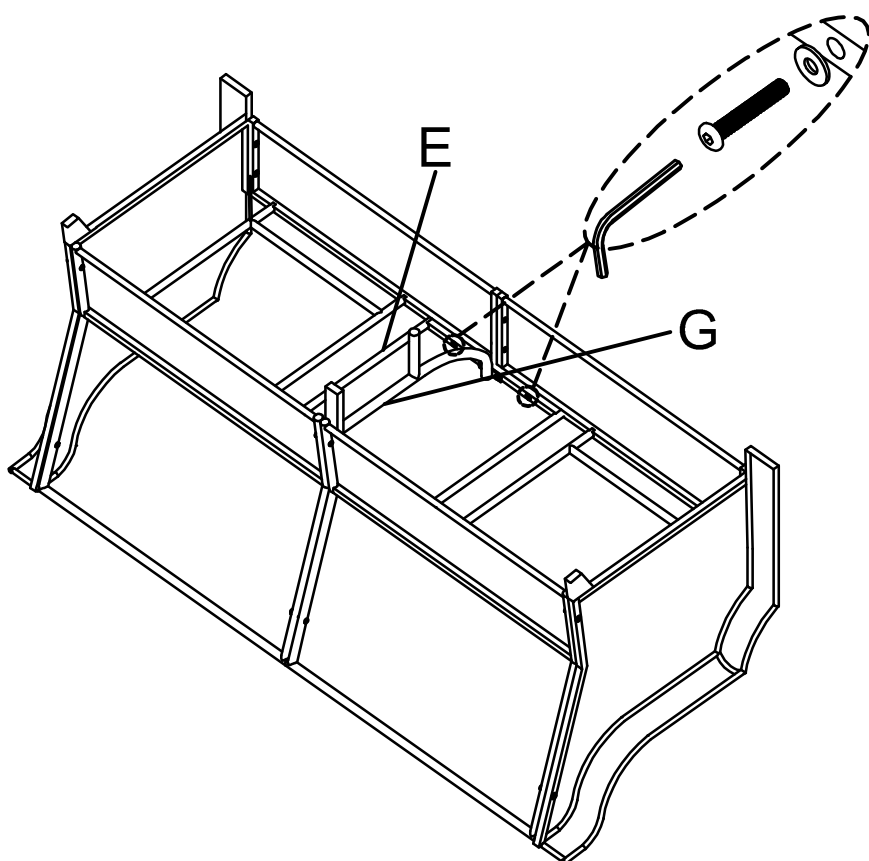

Step 9 : Attach seat to back with 6pcs bolts J and 6pcs washer K.
using Allen wrench L.

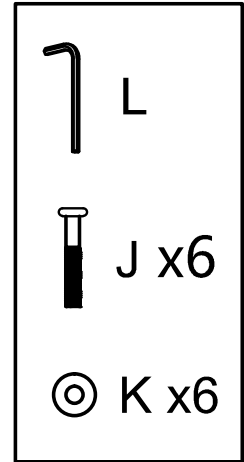
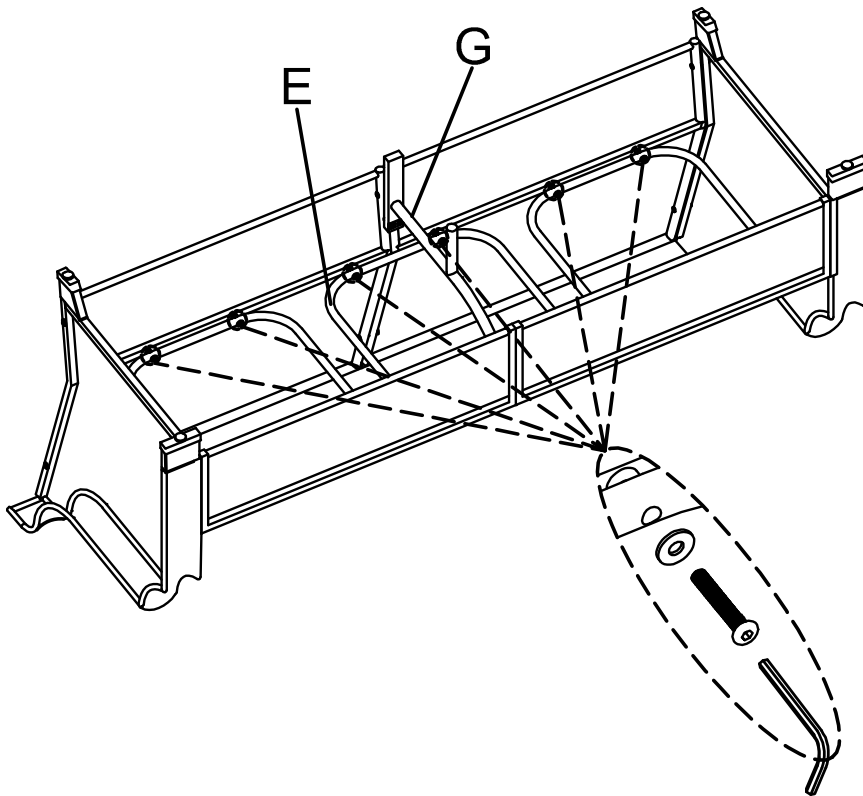

Step 10: Put back cushion O and seat cushion N onto the seat . Assembly is now complete and the product is ready for use.

