

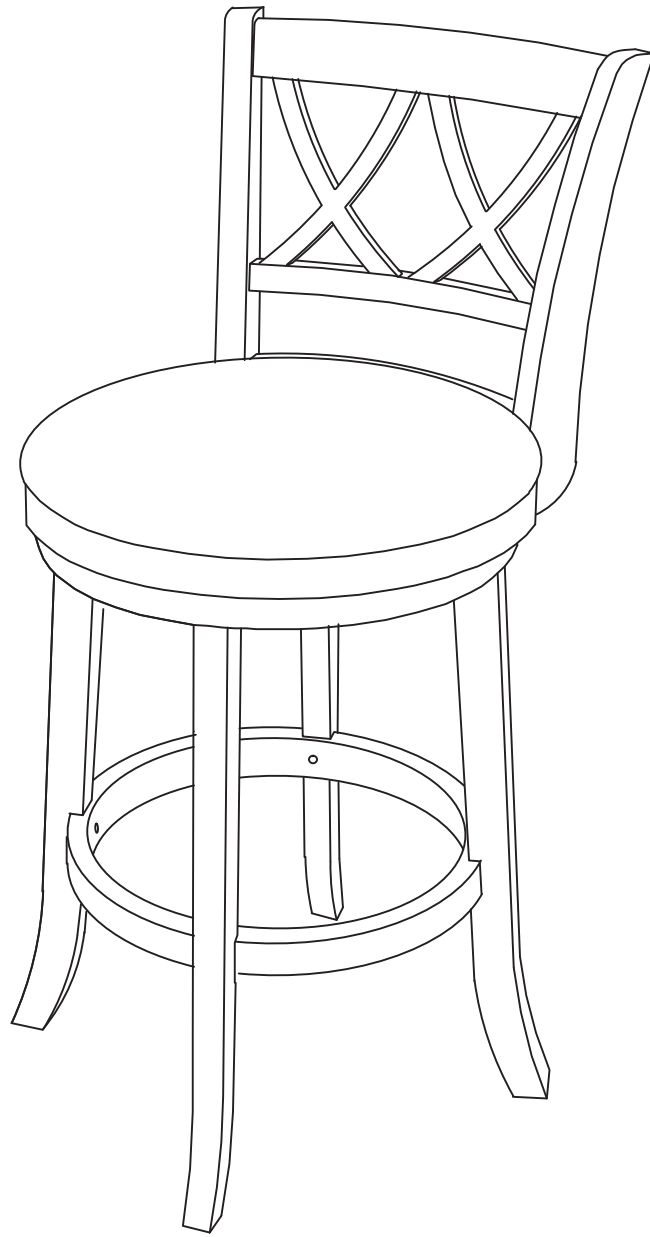

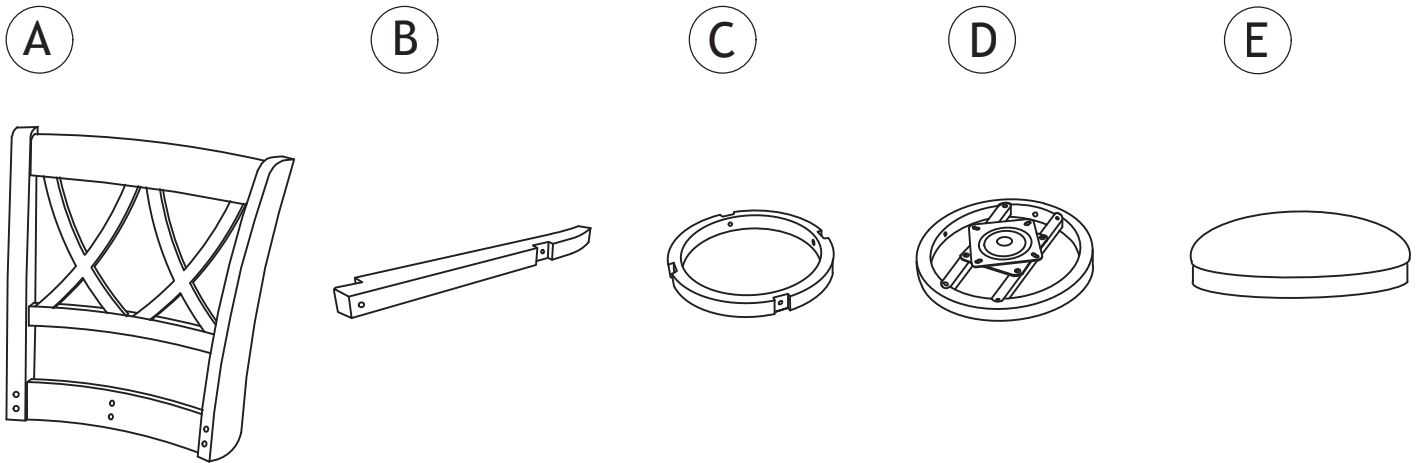

ASSEMBLY INSTRUCTIONS

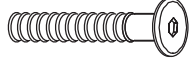

Read this instruction carefully. Refer hardware and furniture parts list for guidance. Be sure all parts are complete before assembling. Place all wooden furniture part on a clean and flat soft surface to prevent scratches. Refer steps provided as assembling guide.

PART LIST		
ITEM	DESCRIPTION	QTY
A	Backrest	1 PC
B	Chair Leg	4 PCS
C	Footrest	1 PC
D	Apron	1 PC
E	Cushion with Apron	1 PC



HARDWARE LIST		
ITEM	DESCRIPTION	QTY
1	JCBC Screw M6 x 25mm 	4 PCS
2	JCBC Screw M6 x 40mm 	10 PCS
3	Spring Washer M6 x 13mm 	14 PCS
4	Flat Washer M6 x 16.5mm 	14 PCS
5	Allen Key Small M4 x 110mm 	1 PCS
6	JCBC Screw M6 x 35mm 	4 PC

STEP 1

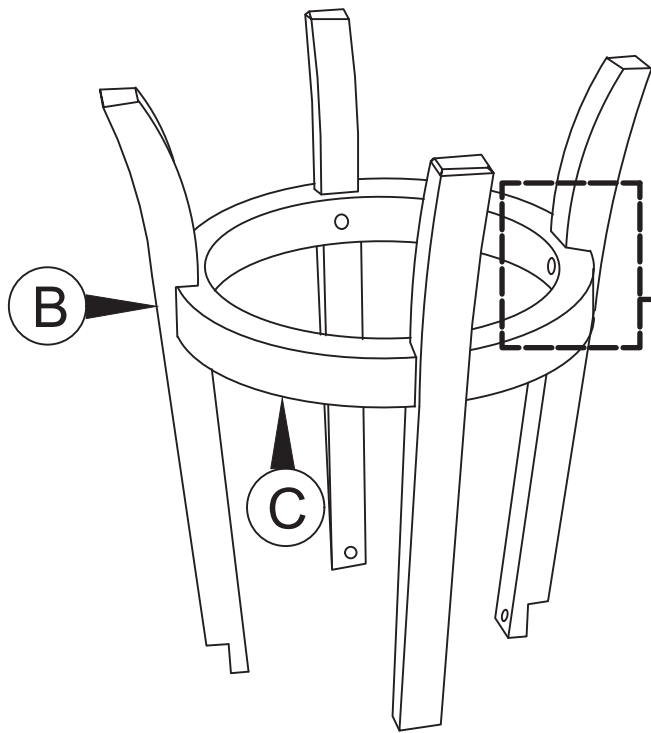

 **Do not tight up any hardware completely!**

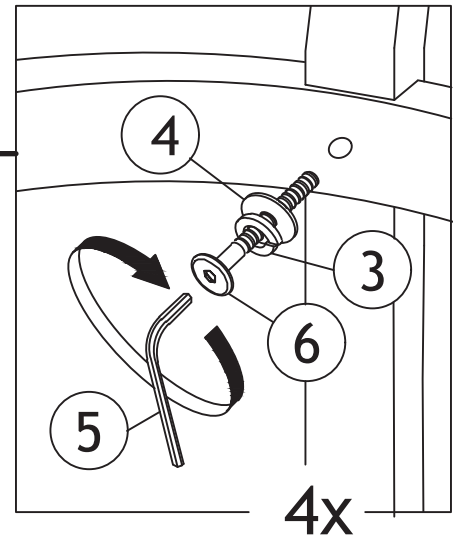

Attach each leg (B) to footrest (C). Insert each individual set of hardware as per picture shown.

STEP 2

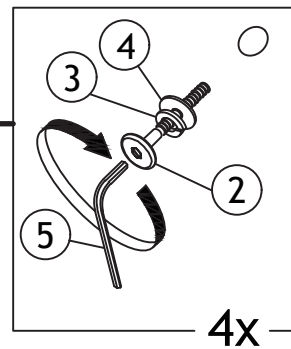
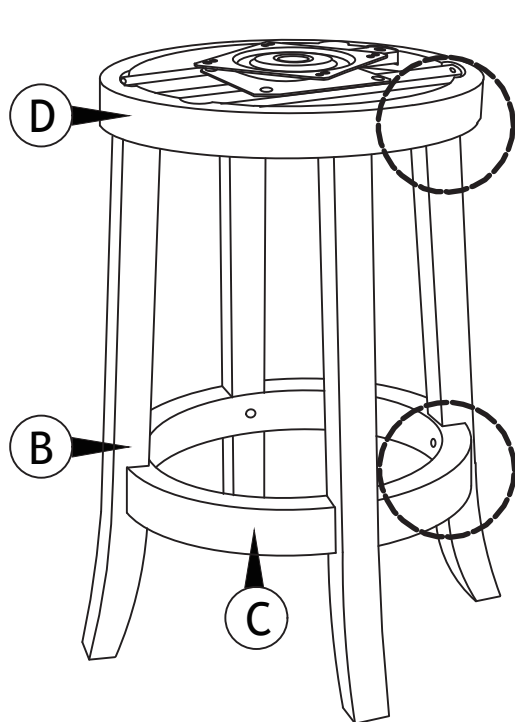

step ii

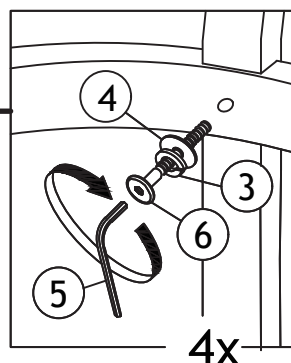

step i

Attach each leg (B) to apron (D). Insert each individual hardware as per picture shown. Tighten part(B) with part(C) first, then tighten part(B) with part(D) completely.

STEP 3

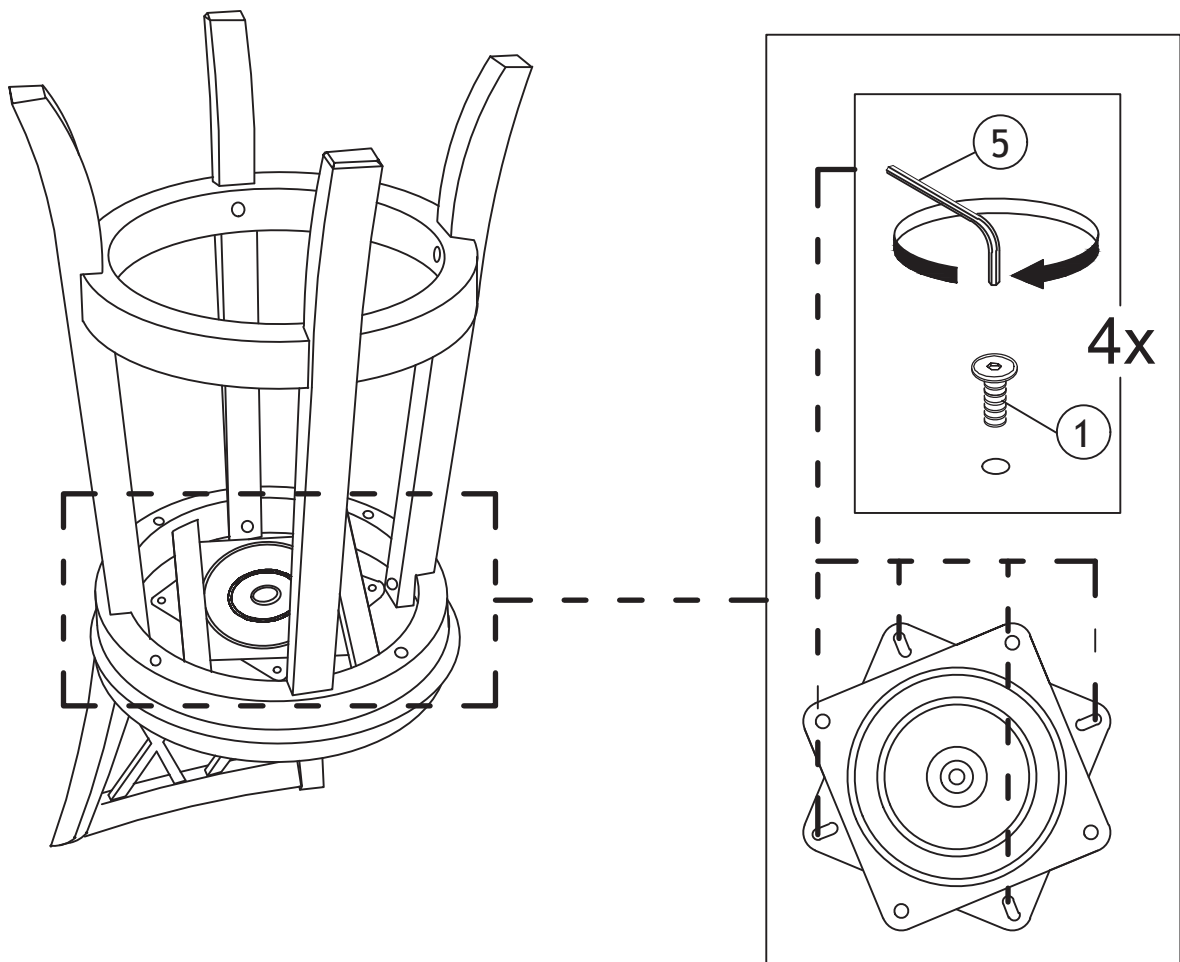

STEP 4

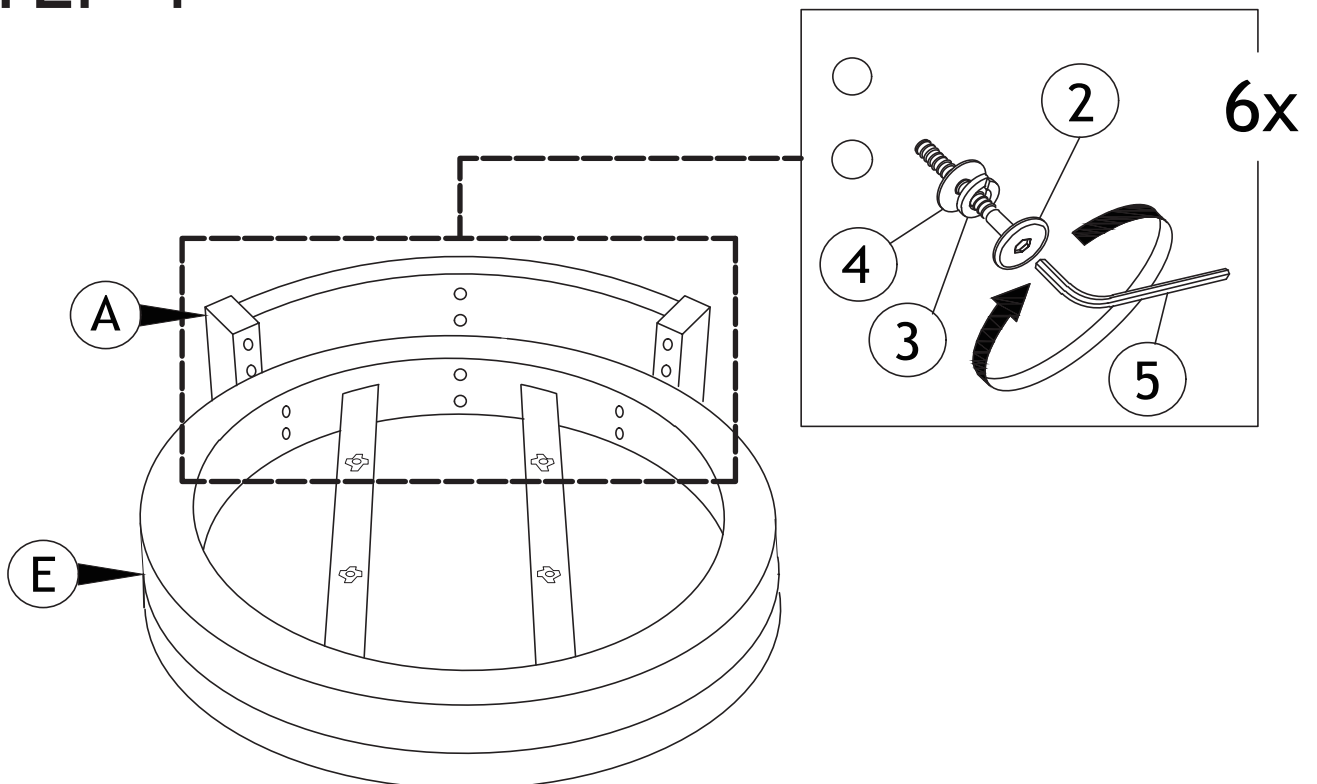

Insert 6 sets hardware first, then tight up part (A) with part (E) together after alignment is done.

AFTER-SALE SERVICE

If you have any suggestions for our products or find that the products have quality problems, please contact us first, our after-sales team will reply you within 24 hours, and we will do our best to give you solutions until you are satisfied.

Guaranteed Customer Service

Your shopping experience is very important to us!
Feel unsatisfied? **Contact us!**
Have any questions? **Contact us!**

Wanna share your experience with our products?
Share your pictures with us.

Any suggestions? **Contact us!**
We gotcha back!