

**2-DOOR CABINET WITH DRAWERS
WHITE / BLACK / GREY / SAGE**

Instruction manual

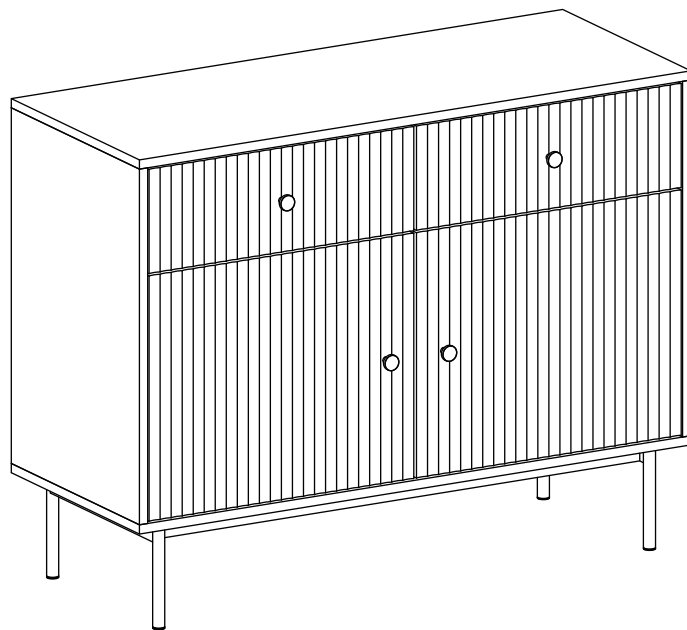



SAFETY AND CARE ADVICE

PLEASE READ THESE INSTRUCTIONS CAREFULLY AND KEEP FOR FUTURE

- Check you have all the components and tools listed on pages 2 or 3.
- Remove all fittings from the plastic bags and separate them into their groups.
- Keep children and animals away from the work area, small parts could choke if swallowed.
- Make sure you have enough space to layout the parts before starting.
- Do not stand or put weight on the product, this could cause damage.
- Assemble on a soft level surface to avoid damaging the unit or your floor (use opened out unit carton).
- We do not recommend the use of power drill/drivers for inserting screws, as this could damage the unit. Only use hand screwdrivers.

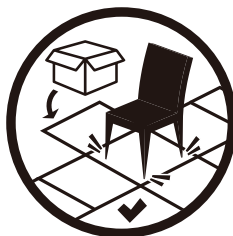

COMPONENTS — PANELS

Please check you have all the panels listed below:

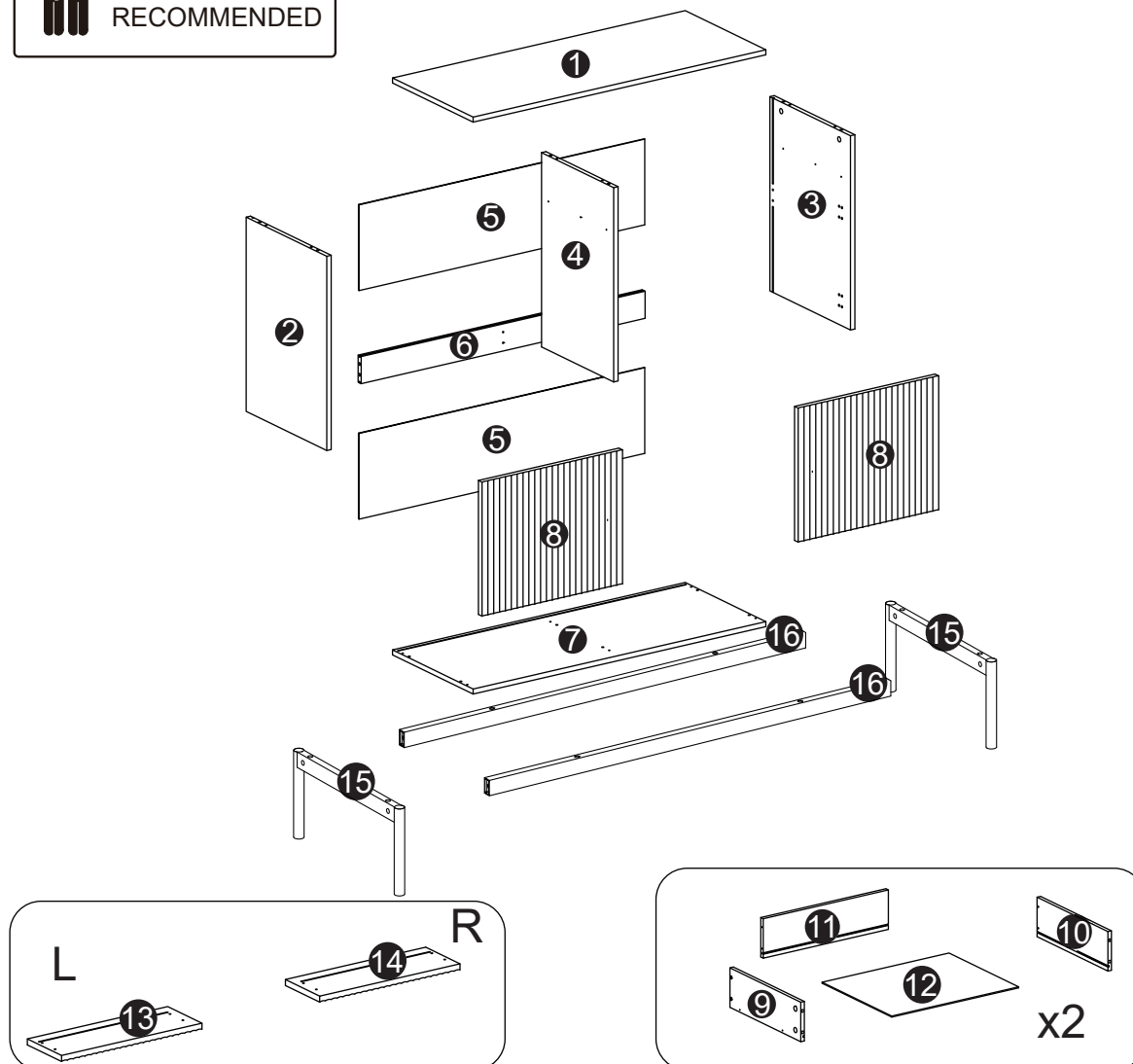
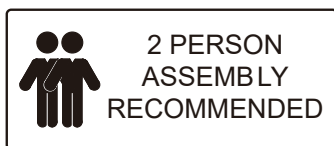









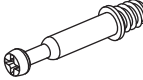

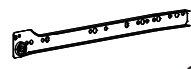

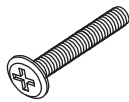

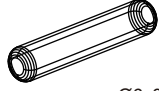

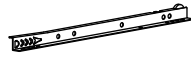

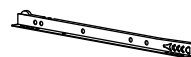
PANEL LIST

1	Top Panel	x1	7	Bottom Panel	x1	13	Left Drawer Front Panel	x1
2	Left Side Panel	x1	8	Door Panel	x2	14	Right Drawer Front Panel	x1
3	Right Side Panel	x1	9	Drawer Left Side Panel	x2	15	Iron Feet	x2
4	Middle Vertical Panel	x1	10	Drawer Right Side Panel	x2	16	Bottom Bar	x2
5	Back Panel	x2	11	Drawer Back Panel	x2			
6	Back Support Bar	x1	12	Drawer Bottom Panel	x2			

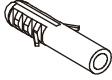
COMPONENTS — FITTINGS

Please check you have all the fittings listed below:

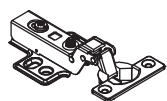
- | | | |
|--|---|---|
| <p>A 
M6x35 mm
Bolt x 18</p> | <p>H 
Ø4x12 mm
Screw x 2</p> | <p>O 
CL
Drawer Runner X 2</p> |
| <p>B 
Lock x 18</p> | <p>I 
Ø6x40 mm
Screw x 12</p> | <p>P 
CR
Drawer Runner X 2</p> |
| <p>C 
Ø6x30 mm
Wooden Dowel x 12</p> | <p>J 
Back Buckle x 8</p> | <p>Q 
DL
Drawer Runner X 2</p> |
| <p>D 
Ø4x40 mm
Screw x 8</p> | <p>K 
Handle x 4</p> | <p>R 
DR
Drawer Runner X 2</p> |
| <p>E 
Ø4x30mm
Screw x 10</p> | <p>L 
Ring Washer x 4</p> | <p>S 
180 mmx20 mm
Wall strap x 2</p> |
| <p>F 
Ø3x16 mm
Screw x 8</p> | <p>M 
Ø6x30 mm
Plastic Expansion Pipe x 2</p> | <p>T 
Ø4x14 mm
Screw x 24</p> |
| <p>G 
Ø3x12 mm
Screw x 20</p> | <p>N 
Ø4x20mm
Screw x 4</p> | <p>U 
Full Overly Hinge x 4</p> |

TOOLS NEEDED
(We don't provide)

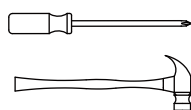

Phillips Screwdriver x 1
Hammer x 1

ASSEMBLY INSTRUCTIONS

Step 1

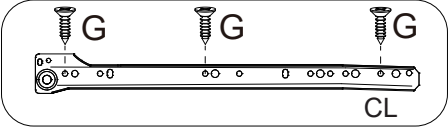
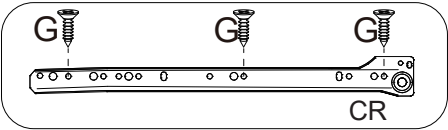

A		4	
G		12	

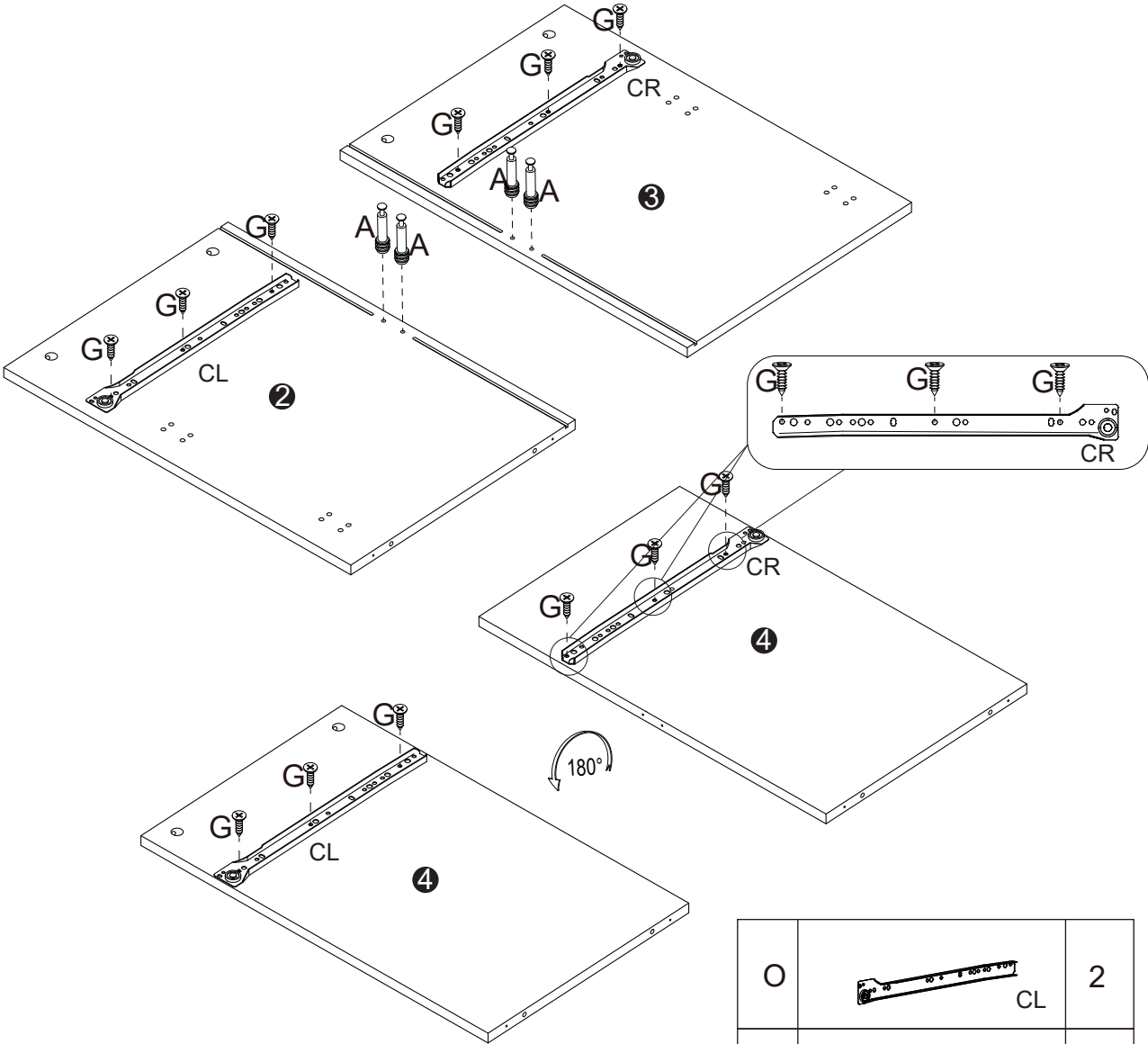



O		2
P		2

ASSEMBLY INSTRUCTIONS

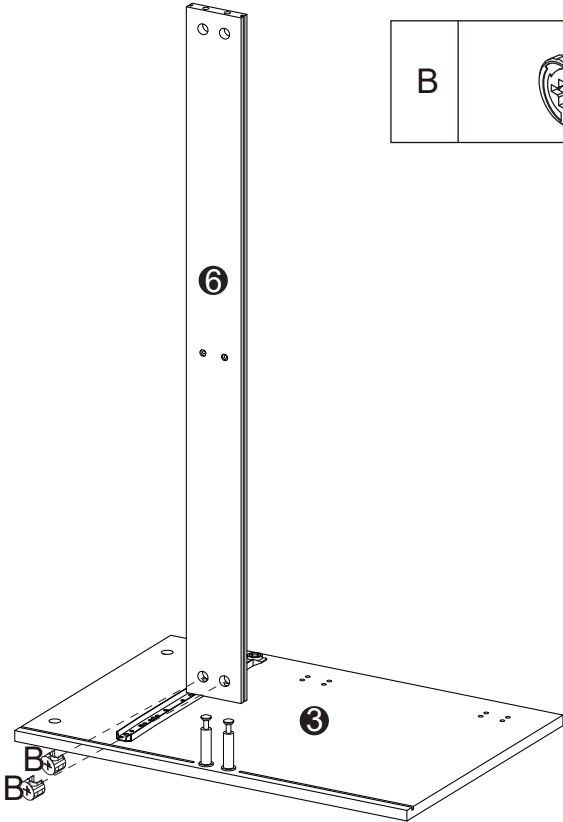



Step 2

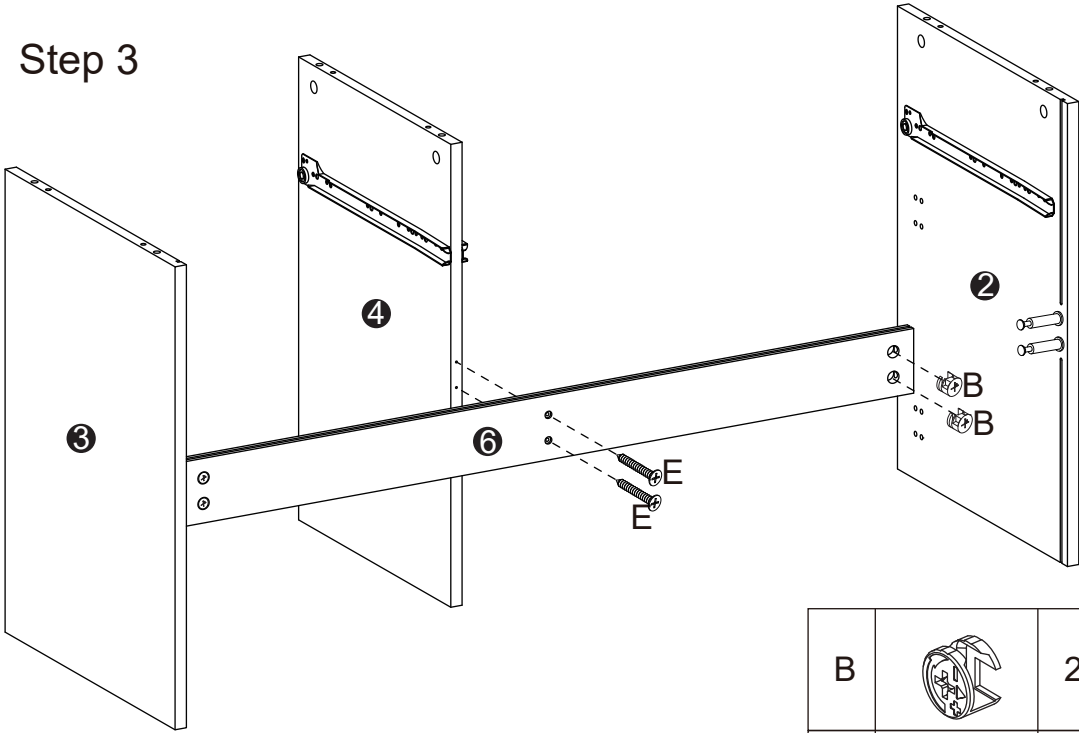

B		2	
---	---	---	---

Step 3

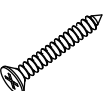

B		2	
E		2	

ASSEMBLY INSTRUCTIONS

Step 4

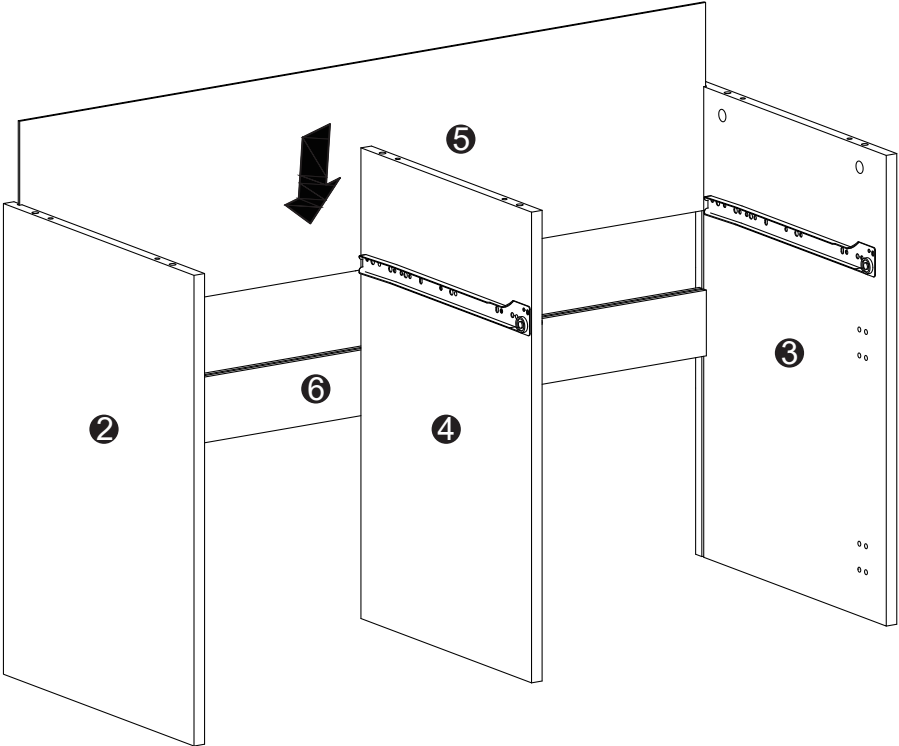

Step 5

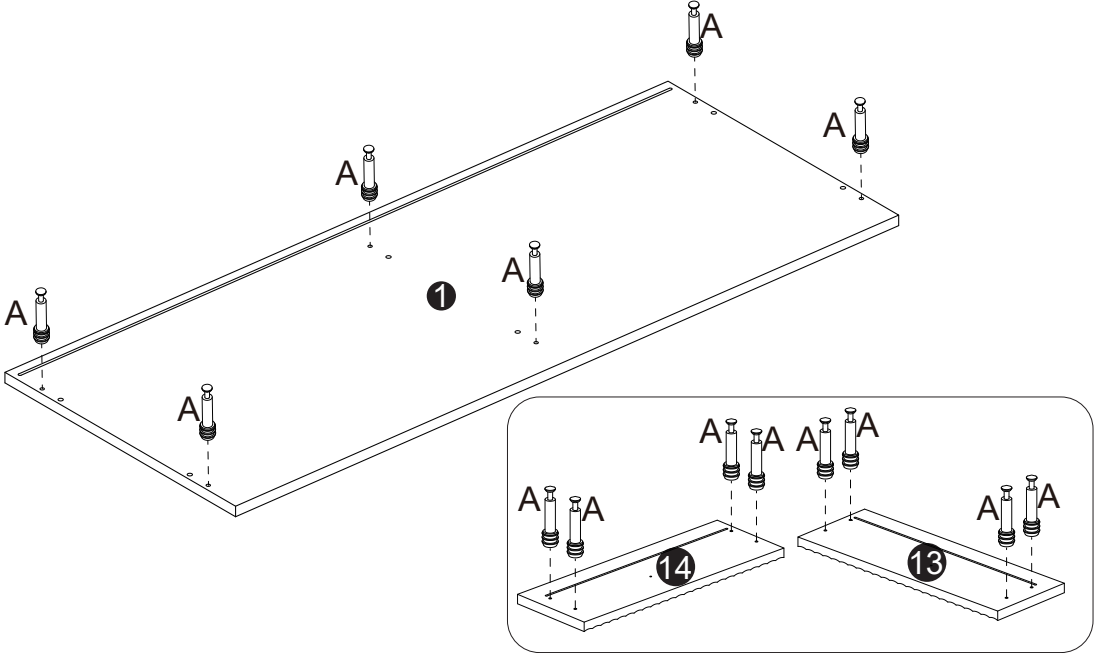
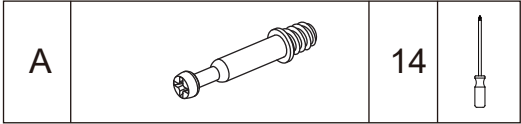

ASSEMBLY INSTRUCTIONS

Step 6

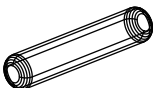
B		6	
C		6	

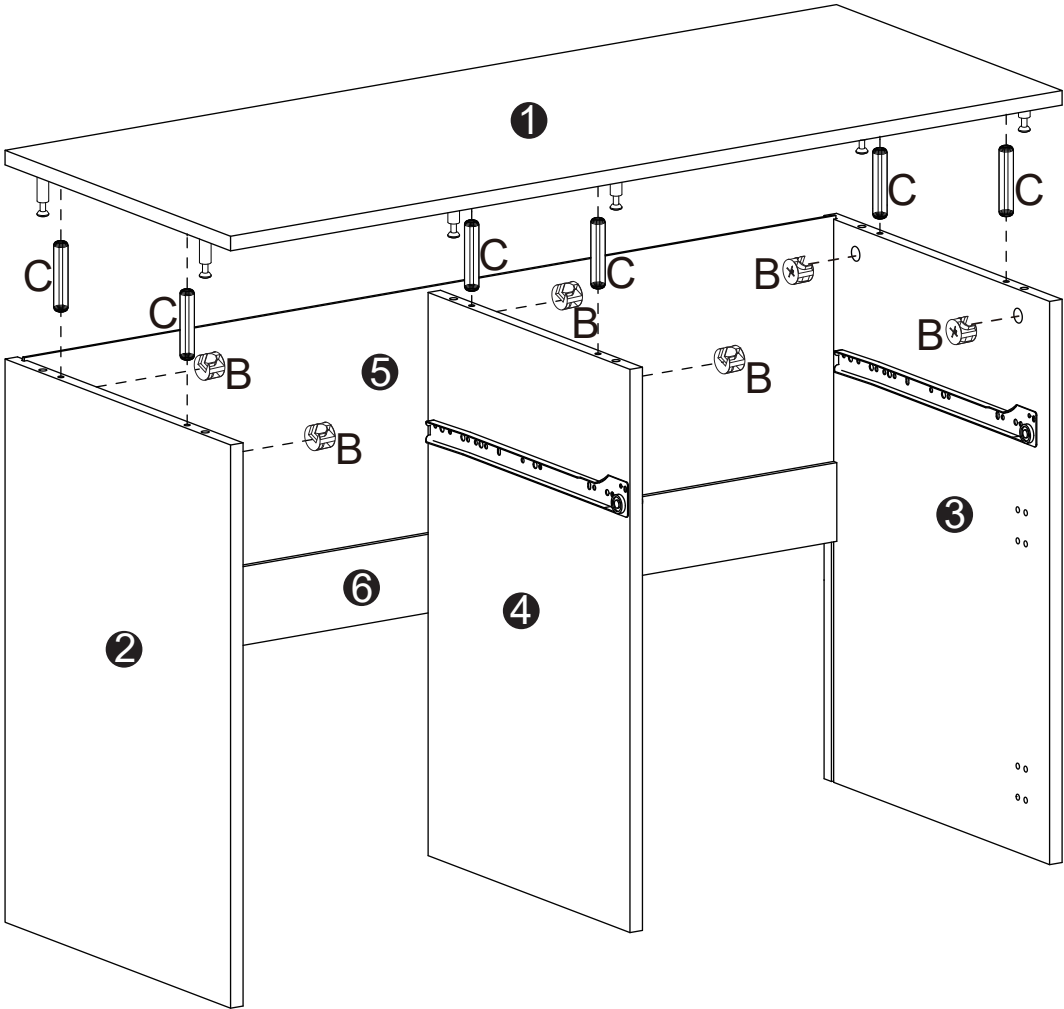

ASSEMBLY INSTRUCTIONS

Step 7

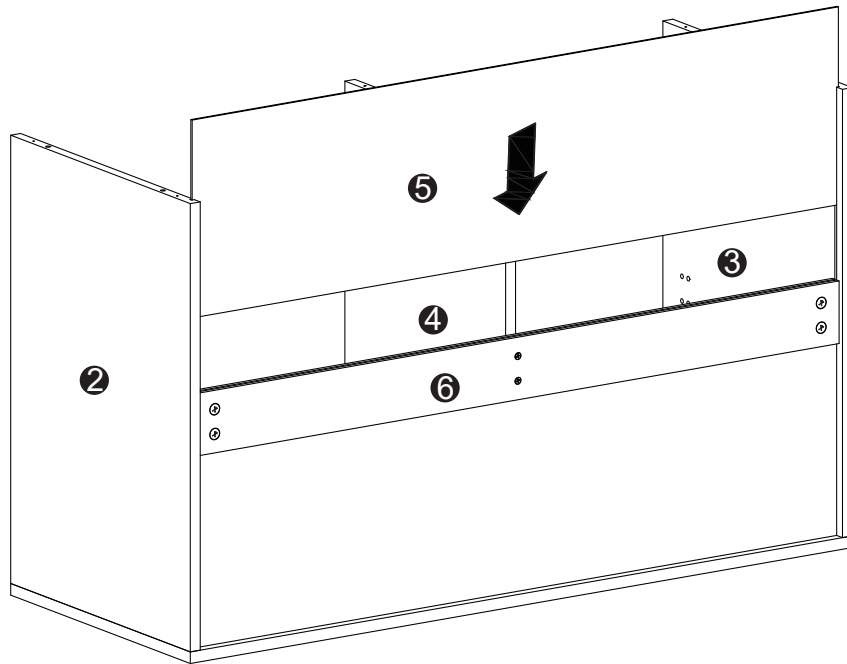

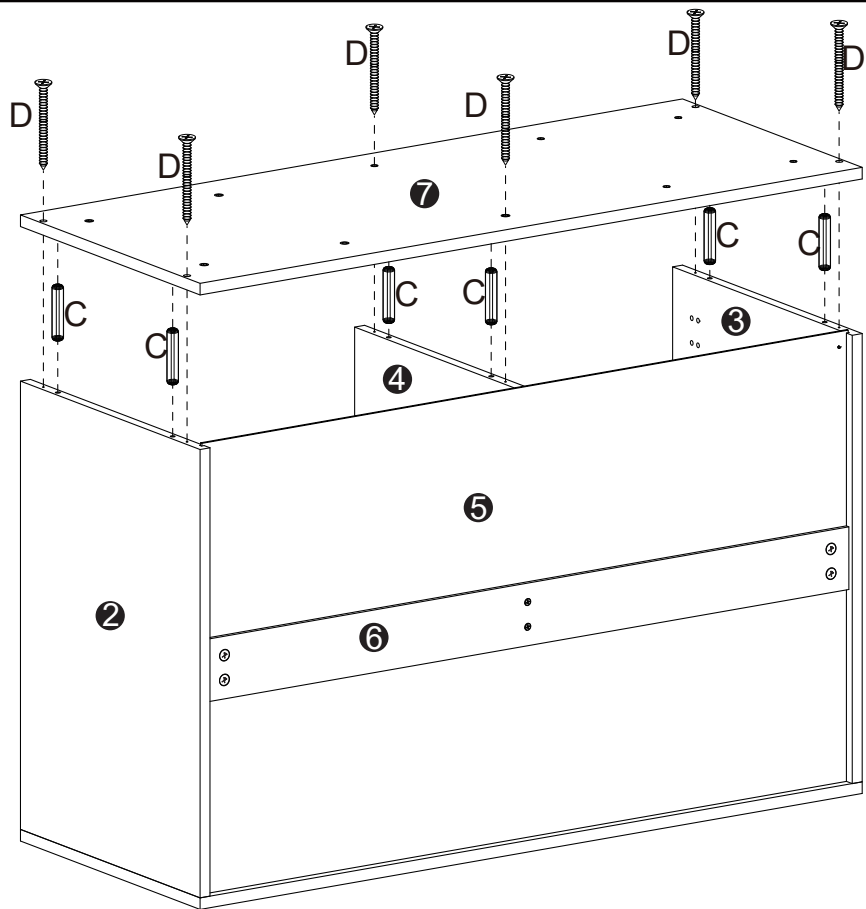

Step 8



ASSEMBLY INSTRUCTIONS

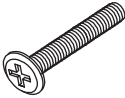

Step 9

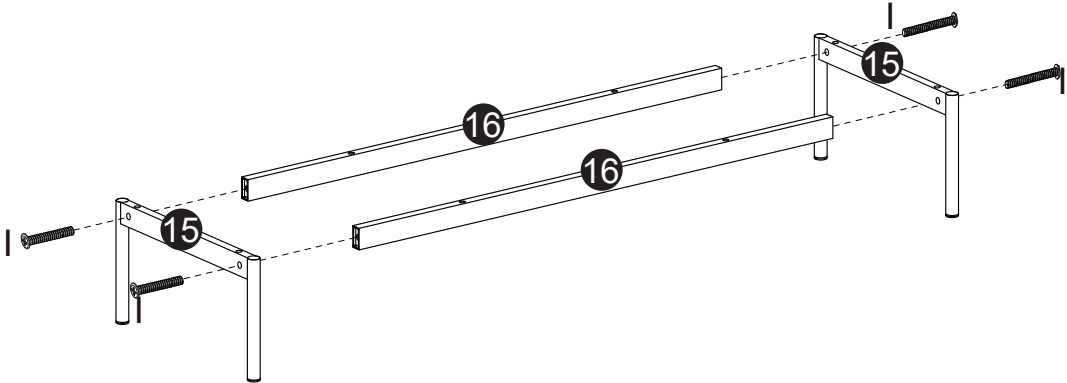
1		4	
---	---	---	---



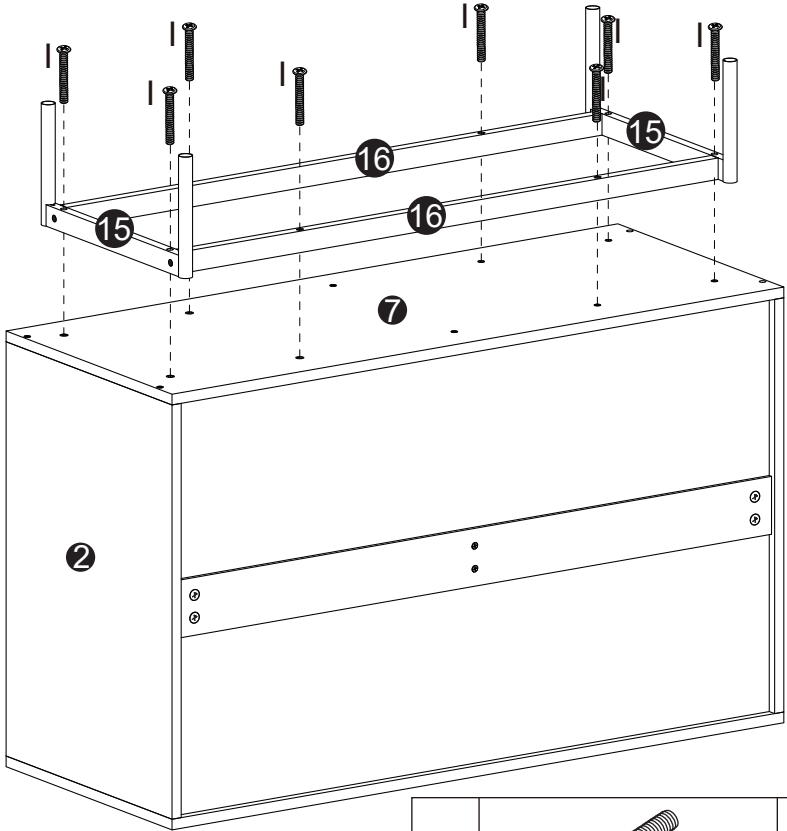

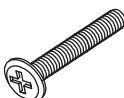
Step 10



1		8	
---	---	---	---

ASSEMBLY INSTRUCTIONS

Step 11

J		8	
F		8	

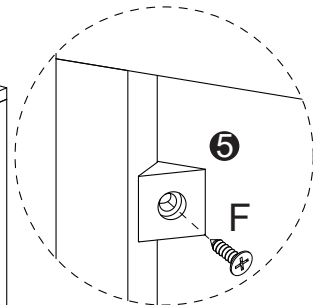
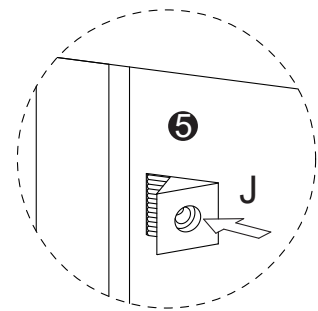
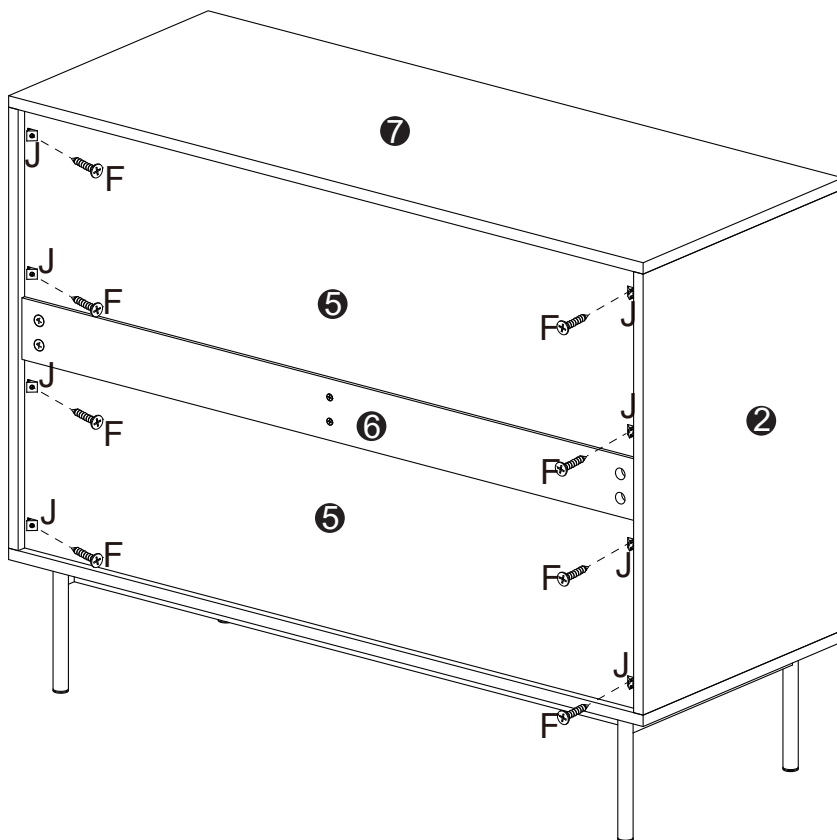

ASSEMBLY INSTRUCTIONS

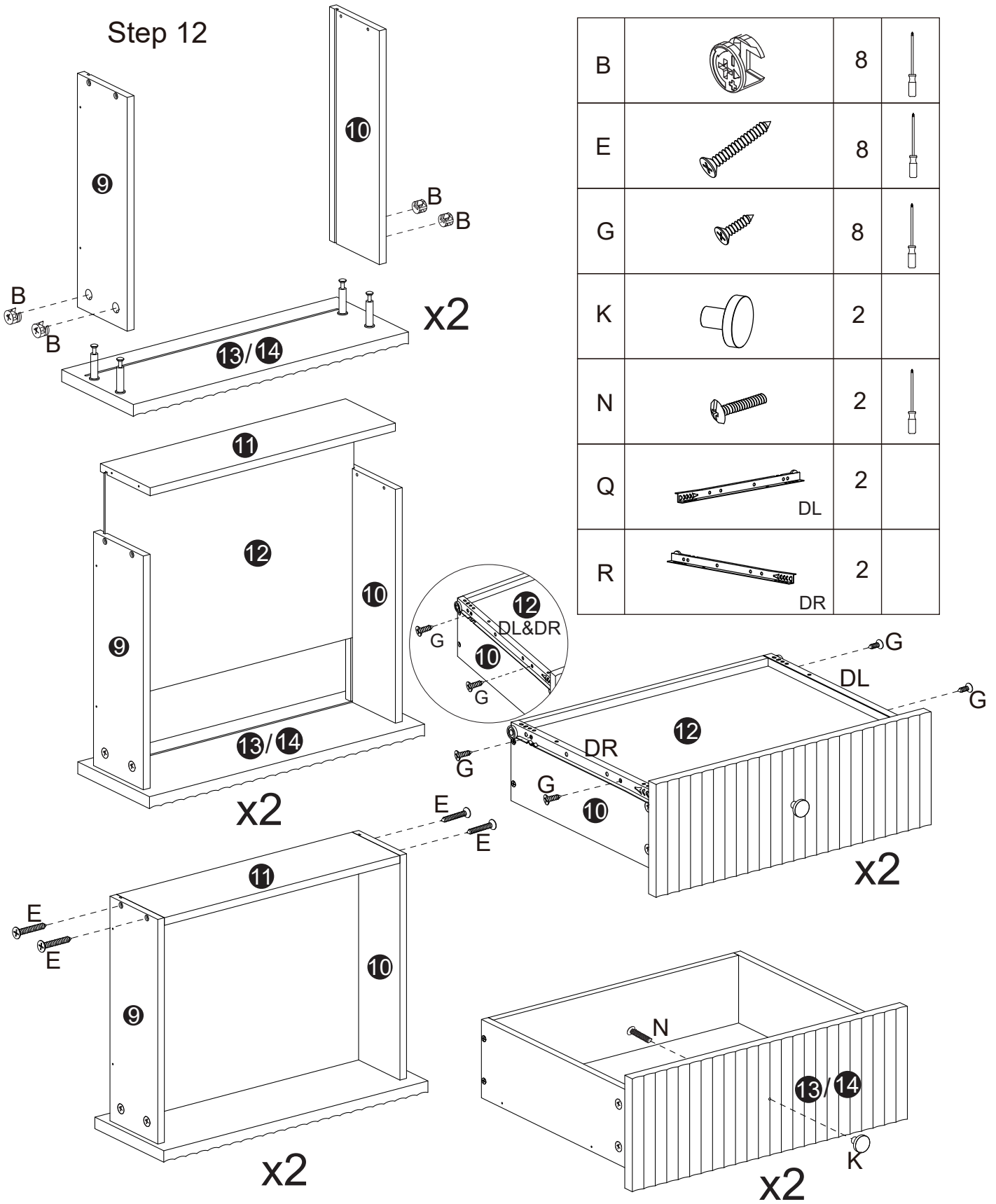

Step 12



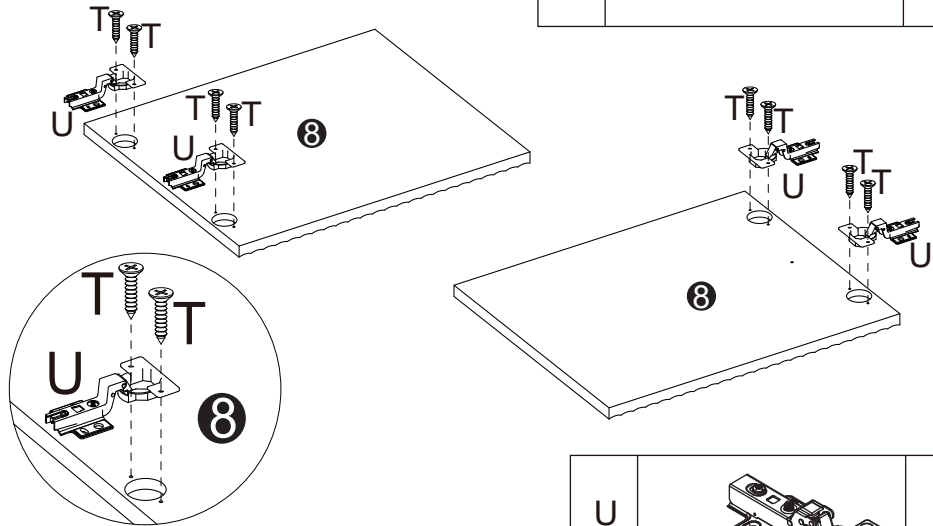

ASSEMBLY INSTRUCTIONS

Step 13



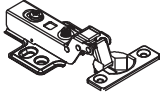

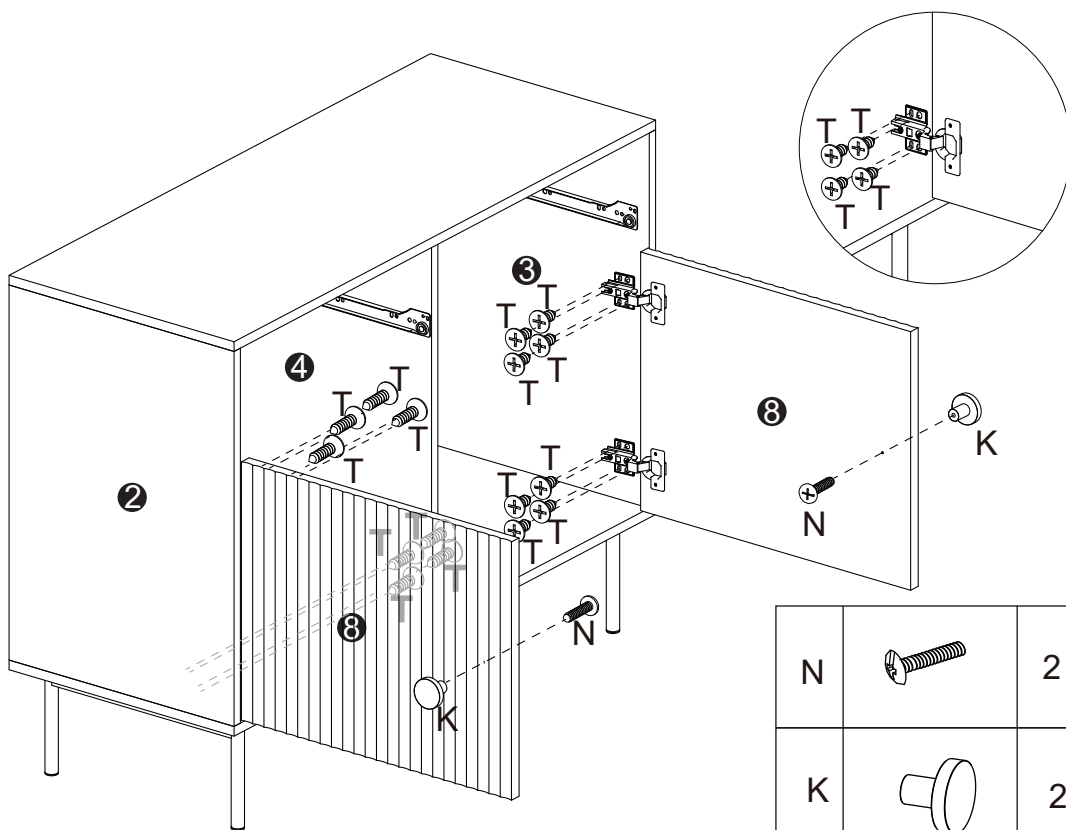

T		8	
---	---	---	---

U		4	
---	---	---	---

Step 14



T		16	
---	---	----	---

N		2	
K		2	

ASSEMBLY INSTRUCTIONS

Step 15

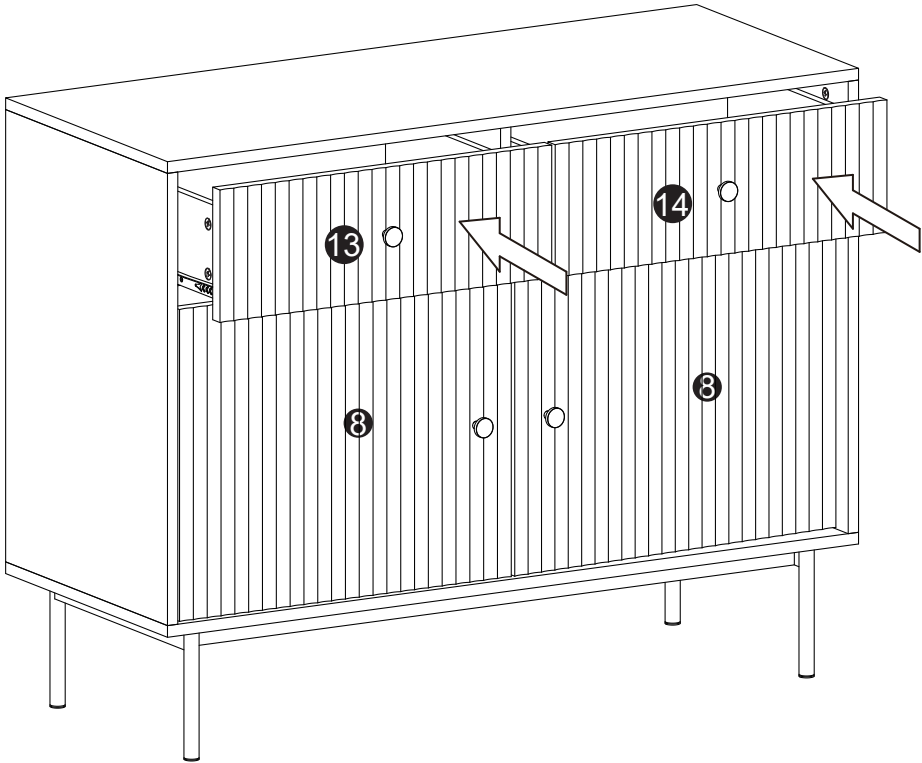

ASSEMBLY INSTRUCTIONS

Step 16

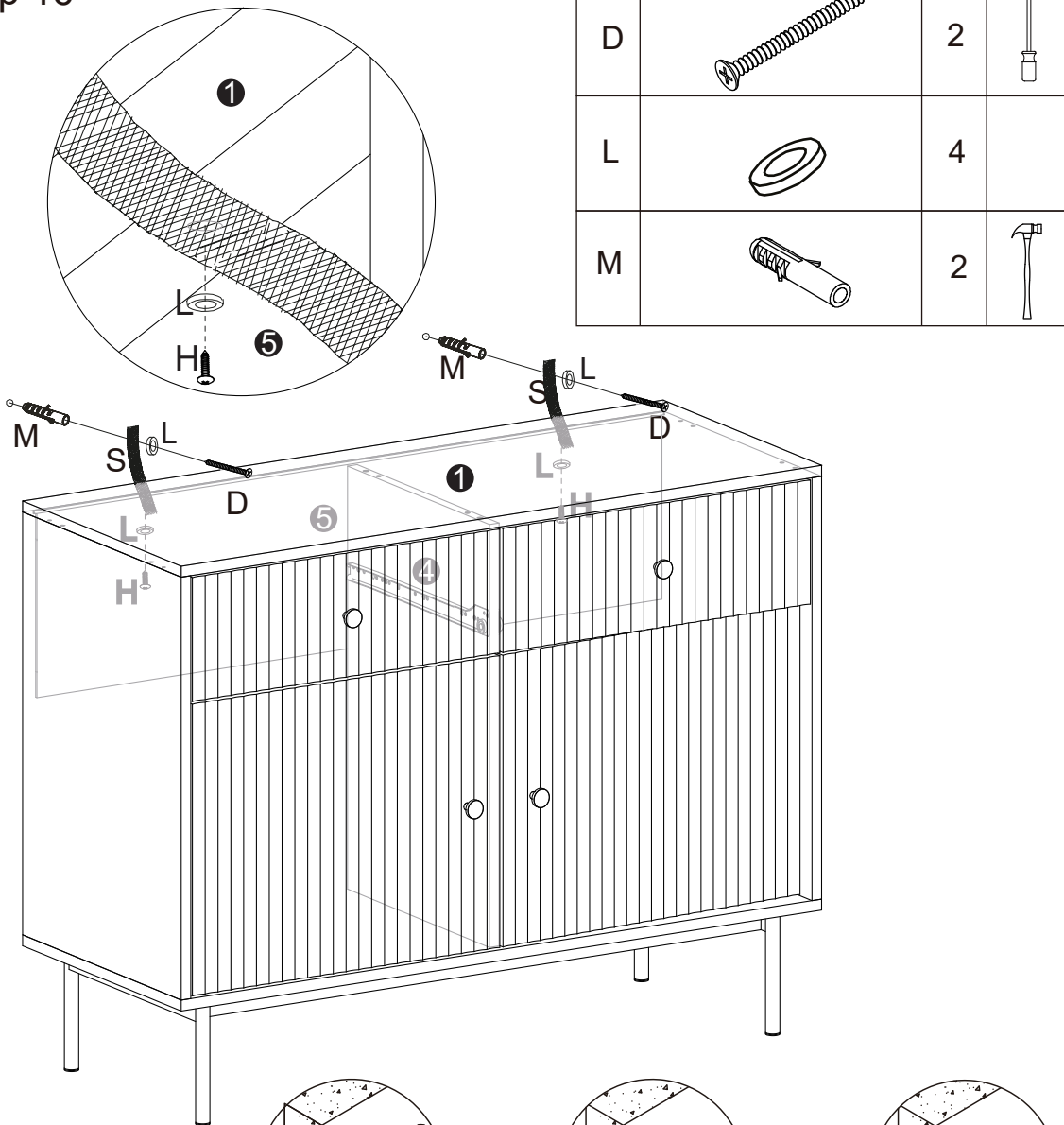

D		2	
L		4	
M		2	

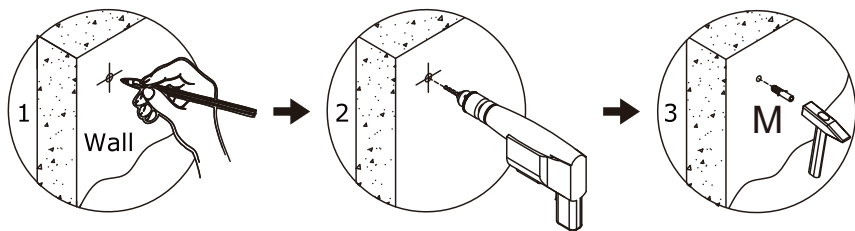

H		2	
S		2	

*Congratulations!
Now you have finished assembling the product.*

ASSEMBLY INSTRUCTIONS



Customer Attention:

To align doors and control gap in between doors. Product doors may need adjusting during and after assembly. This can be done by adjusting appropriate screws. See below illustration.

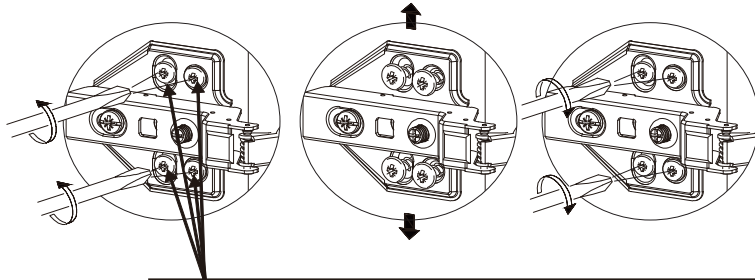
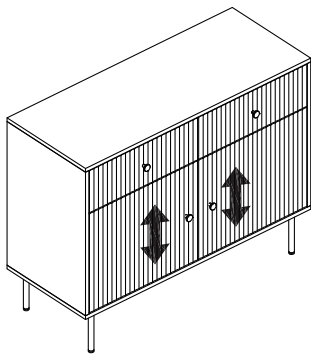

Vertical Door Adjustment:

Loosen both screws on all hinges and lift the door to the desired height. This allows an even space at the top and bottom between the door and frame.

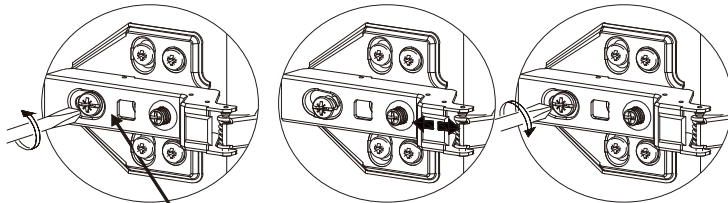
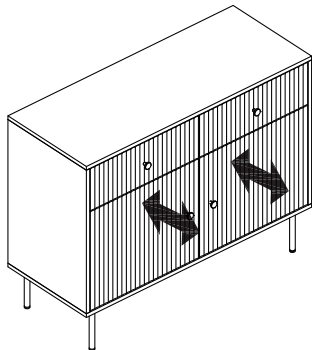

Lateral Door Adjustment:

If door is hinge bound, (rubbing on frame as you close or open door) loosening screw shown and move the door in appropriate direction. (In or out)

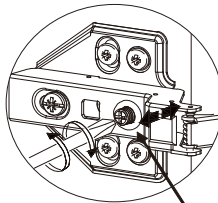
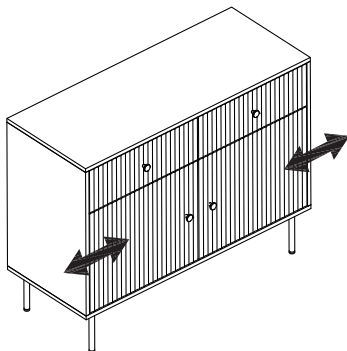

Horizontal Door Adjustment:

Rotate Screw clockwise or anticlockwise. This will produce an even gap between doors and frame.

A Guide to - Wall Mounting & Fixings

Important note:

If plastic wall plugs are supplied with your product:



- these are only suitable for use in masonry walls.

If you are in any doubt about the correct wall plugs for your wall, seek professional advice.

Failure of the product due to using incorrect fixings is the responsibility of the installer.



Important: When drilling into walls always check that there are no hidden wires or pipes etc.

Make sure that the screws and wall plugs being used are suitable for supporting your unit. Consult a qualified person if you are unsure.

Hints:

- 1: **General rule:** ⚠ Always use a larger screw and wall plug if you are not sure.
- 2: Ensure you use the recommended drill bit to match the wall plug and hole size.
- 3: Ensure you drill the hole horizontally, do not force the drill or enlarge the hole.
- 4: Take extra care when drilling high walls, ceilings and ceramic tiles. Ensure wall plugs are inserted beyond the thickness of the ceramic tiles to avoid the tiles splitting or cracking.
- 5: Ensure wall plugs are well fitted and are a tight fit in the drilled hole.

Types of walls

You can use one of the following types of wall plug if your walls are made of brick, breeze block, concrete, stone or wood.

No.1 "General Purpose" wall plug

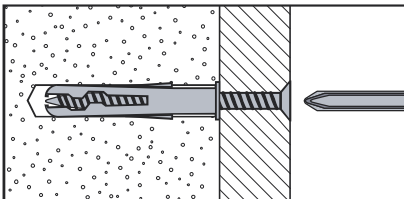

Generally aerated blocks should not be used to support heavy loads, use a specialist fitting in this case. For light loads, general purpose wall plugs can be used.

No.2 "Plasterboard" wall plug

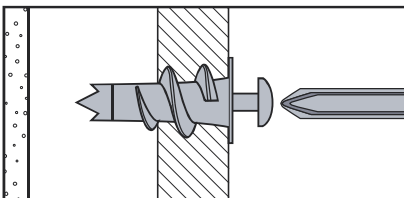

For use when attaching light loads on to plasterboard partitions.

No.3 "Cavity Fixing" wall plug

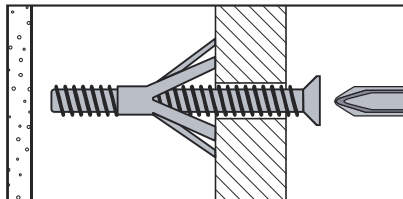

For use with plasterboard partitions or hollow wooden doors.

No.4 "Cavity Fixing-Heavy Duty" wall plug

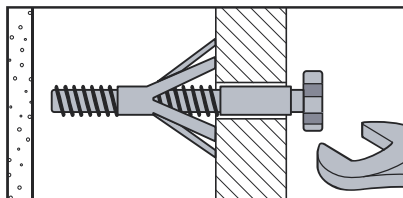

For use when fitting or supporting heavy loads such as shelving, wall cabinets and coat racks.

No.5 "Hammer Fixing" wall plug

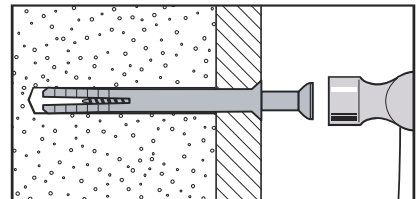

For use with walls stuck with plasterboard. The hammer fixing allows it to be fixed to the wall rather than the plasterboard. Always check the fixing is secure to the retaining wall.

No.6 "Shield Anchor" wall plug Heavy loads

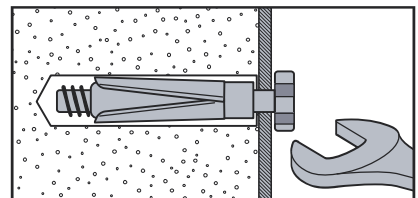

For use with heavier loads such as TV & HiFi speakers and satellite dishes etc.



Care & Maintenance

Safety: Always check the fitting and location to ensure your safety in and around the home.

Fitting: From time to time check the fitting to ensure the wall plugs or screws do not become loose.