

DOOR AWNING : PA SERIES

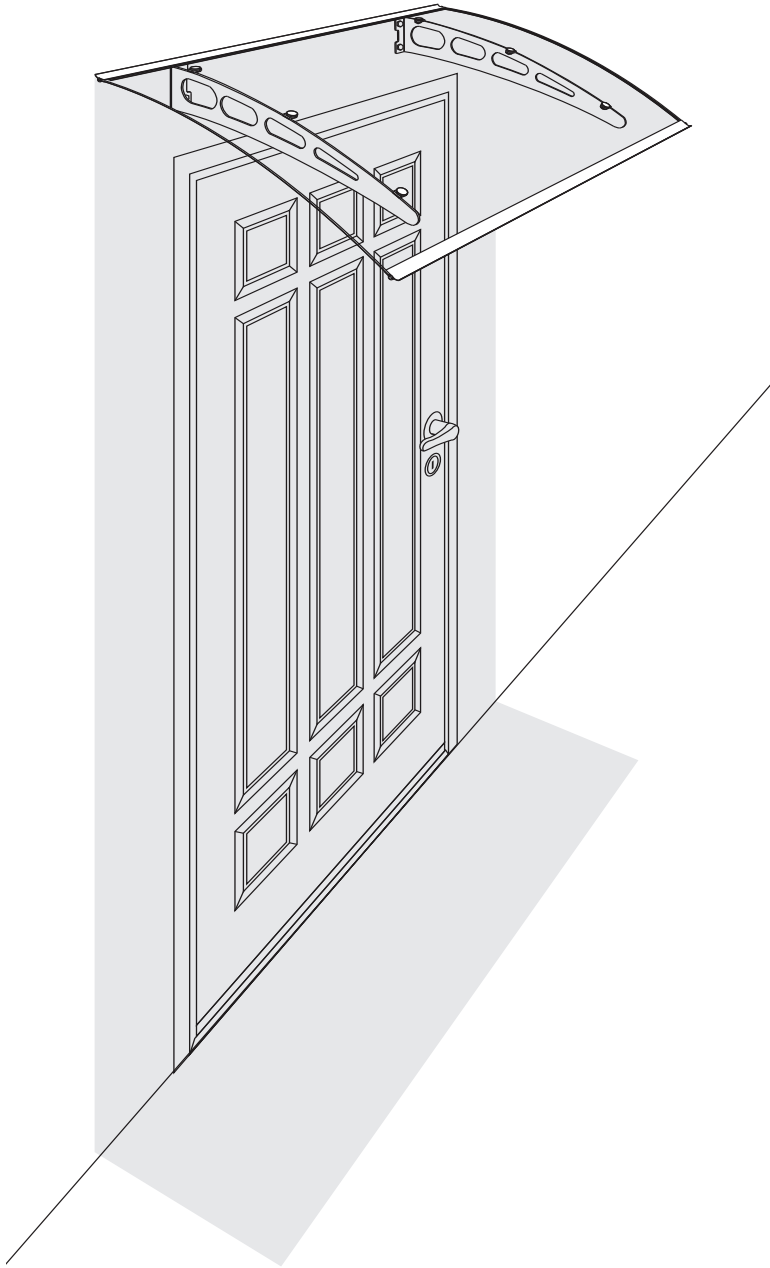

Owner's Manual

For safety reasons, please carefully read and understand all written instructions and warnings in this manual prior to assembling or installing this product.

TABLE OF CONTENTS

Safety instructions and warnings.....	2
Package contents and parts	3
Tool requirements	4
Product features	5
Installation	
Determine door awning location.....	5
Assemble the door awning	6
Install the door awning	9
Maintenance.....	12
Warranty.....	13

MODEL
DA4735-PSS1A
DA5935-PSS1A

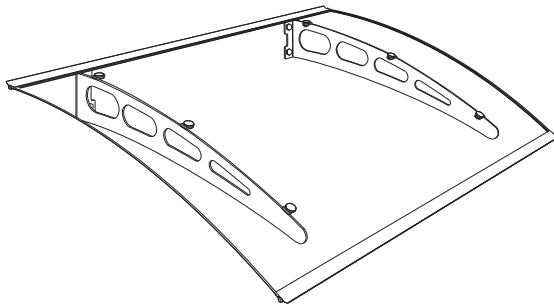

DA4735-PSS2A
DA5935-PSS2A

DA4735-PSS3A
DA5935-PSS3A

MODEL
DA7935-PSS1A
DA9435-PSS1A

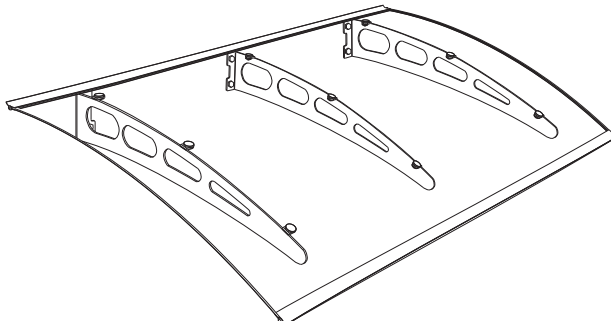

SAFETY INSTRUCTIONS AND WARNINGS

- For safety concerns, please keep children away from the assembly area and from the assembly components.
- Please properly dispose of all packing materials.
- Consult with your local authorities if any permits are required prior to installation of Door Awning.
- Follow all manufacturer's safety instructions when using step ladders and/or power tools during installation.
- Do not drill into walls where electric wiring, gas or water pipes may exist.
- Please ensure that all screws are properly tighten when assembling the Door Awning.

This product is intended for residential use only. DO NOT use this product outside of its intended use as mentioned in this manual or against building codes and regulations of the local area.

Always take care and use appropriate safety equipment and eye protection when assembling and installing this product. You are solely responsible for the proper handling, storage, assembly, installation and use of this product in a safe and appropriate location and given application. Advaning is not responsible for any damages or injury to you, any other parties, or property resulting from improper handling, storage, assembly, installation or misuse of the product.

Please follow all safety warnings and instructions as written or demonstrated in the Advaning User's Manual.



ENSURE THAT THE DOOR AWNING IS MOUNTED TO MAIN STRUCTURAL SUPPORTS OF THE BUILDING. FAILURE TO DO SO MAY RESULT IN INJURY OR DAMAGE TO THE PRODUCT OR PROPERTY.

For safety reasons we strongly recommend the following during installation:

- A: Minimum 2 people
- B: Work gloves
- C: Safty goggles

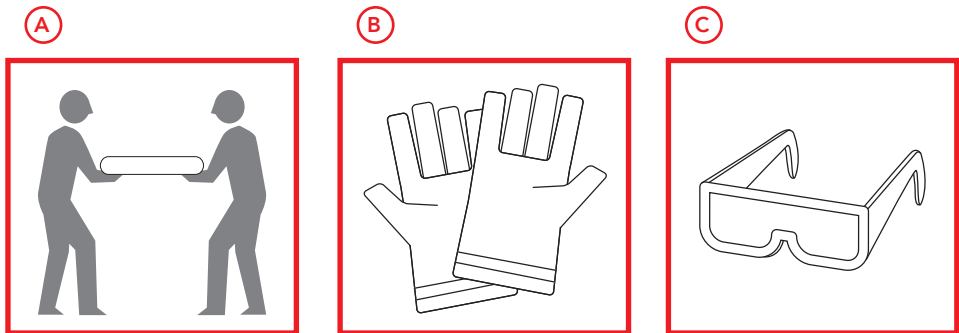

Fig.1

DO NOT ATTEMPT to assemble or install if:

- D: Rain is in the forecast
- E: Wind is in the forecast
- F: You are tired or under the influence of drugs, medication or alcohol

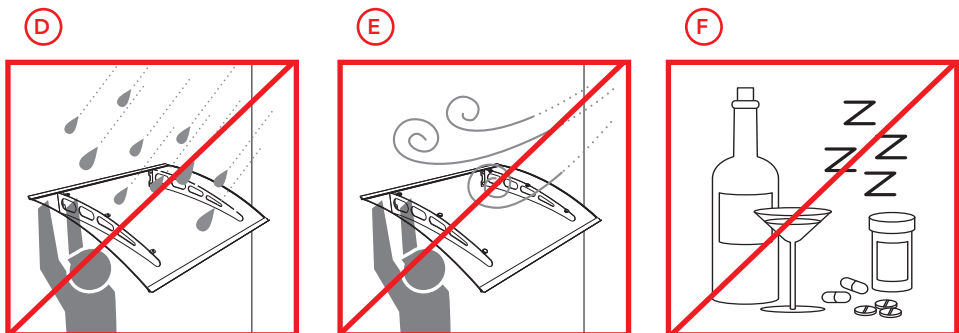

Fig.2

PACKAGE CONTENTS AND PARTS

Before installation, make certain that the package contains all parts as listed on this page.

- ① Awning sheet (1)
- ② Awning bar (2)
- ③ Rubber strip (2)

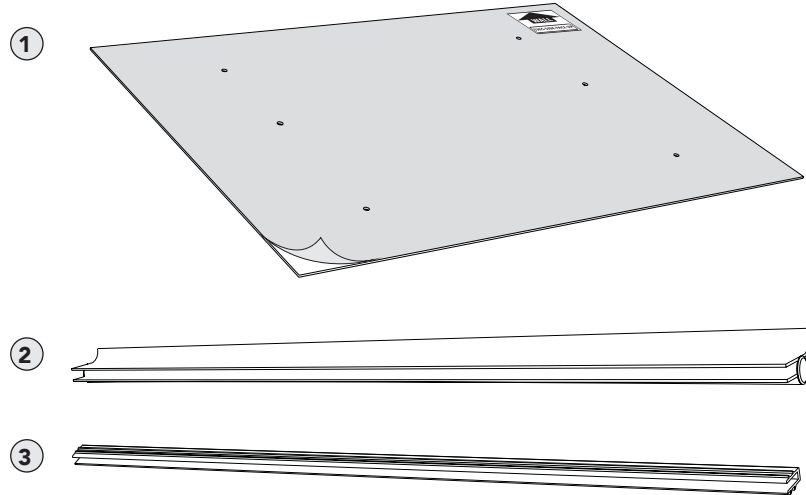

Fig.3

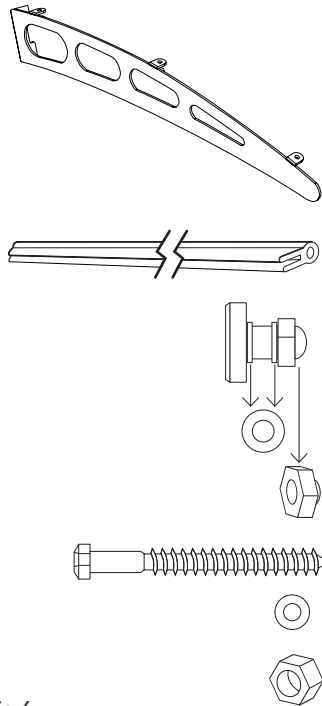

Fig.6

Awning Model	DA4735-PSS1A	DA7935-PSS1A
	DA5935-PSS1A	DA9435-PSS1A
Parts name	Quantity	
Awning bracket	2	3
Wall rubber strip	1	NA
Bracket screw set	6	9
Washer	12	18
Nut	6	9
Lag screw and washer set*	4	6
Lag screw cap	4	6

RECOMMENDATION:

Standard Stud
Installation: Lag Screws*
(included)

Concrete or Brick
Installation: Expansion
Bolts

Please always consult with a hardware specialist or a contractor for the installation requirements and required hardware.

TOOL REQUIREMENTS

RECOMMENDATION

Minimum 2 people to install.

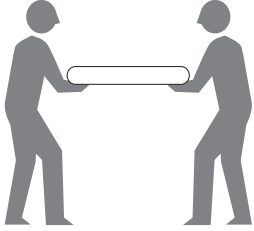

SUGGESTED TOOLS

- ① Marker / pencil
- ② Scissors
- ③ Level
- ④ Wrench
- ⑤ Rubber hammer
- ⑥ Small wood block
- ⑦ 24 Hour silicone
- ⑧ Drill bit
- ⑨ Drill
- ⑩ Ladder

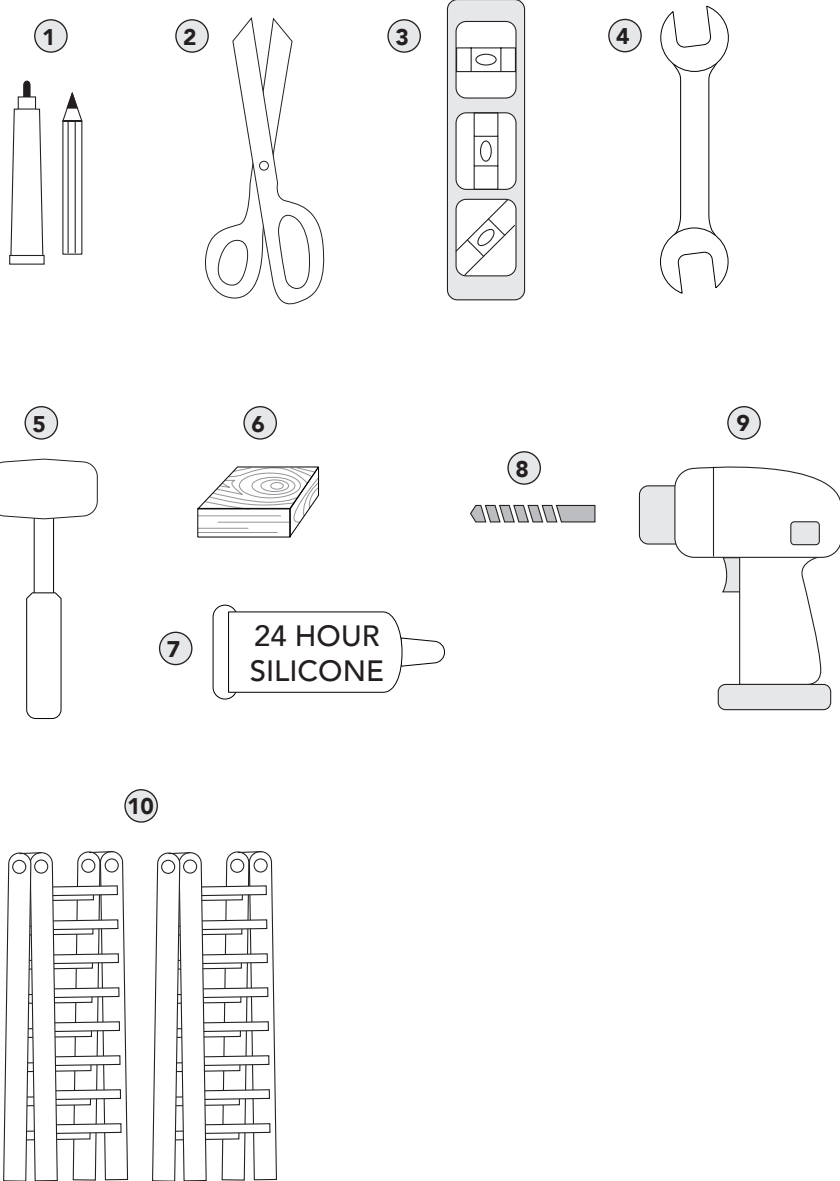
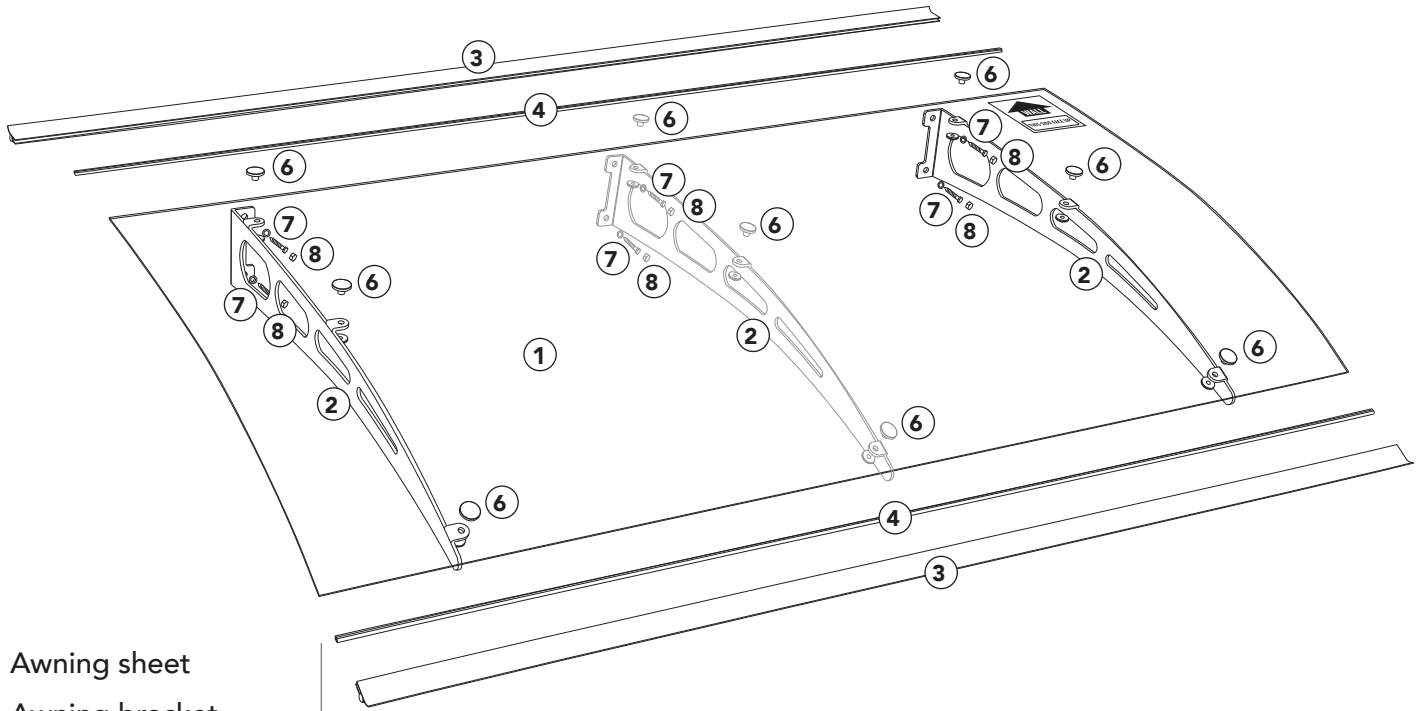

Fig.5

PRODUCT FEATURES



- ① Awning sheet
- ② Awning bracket
- ③ Awning bar
- ④ Rubber strip
- ⑤ Wall rubber strip
(Select models only)
- ⑥ Bracket screw set
- ⑦ Lag screw & washer
set
- ⑧ Lag screw cap

Fig.6

INSTALLATION

DETERMINE THE DOOR AWNING LOCATION



The Door Awning needs to be mounted to the main structural supports of the building.

The surface of the area should be clear of any obstructions along the entirety of the Door Awning.

Locate a position that is:

- Ⓐ Minimum 2 inch of clearance below the roof/eave/overhang.
- Ⓑ At least 10 inch of vertical clear space.
- Ⓒ Minimum depth of 36 inches.

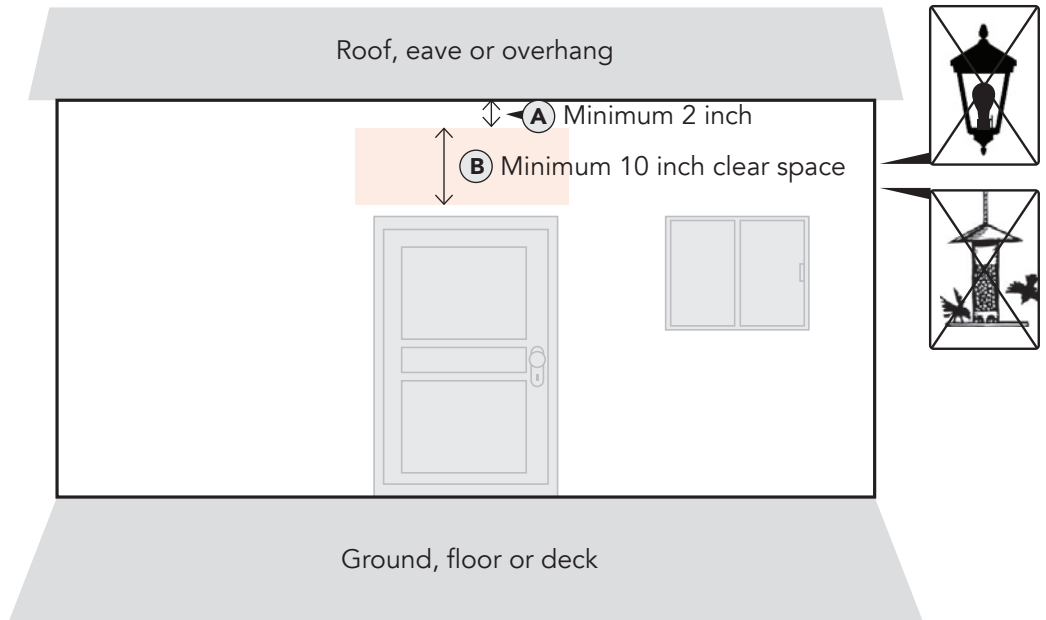

Fig 8

Side view

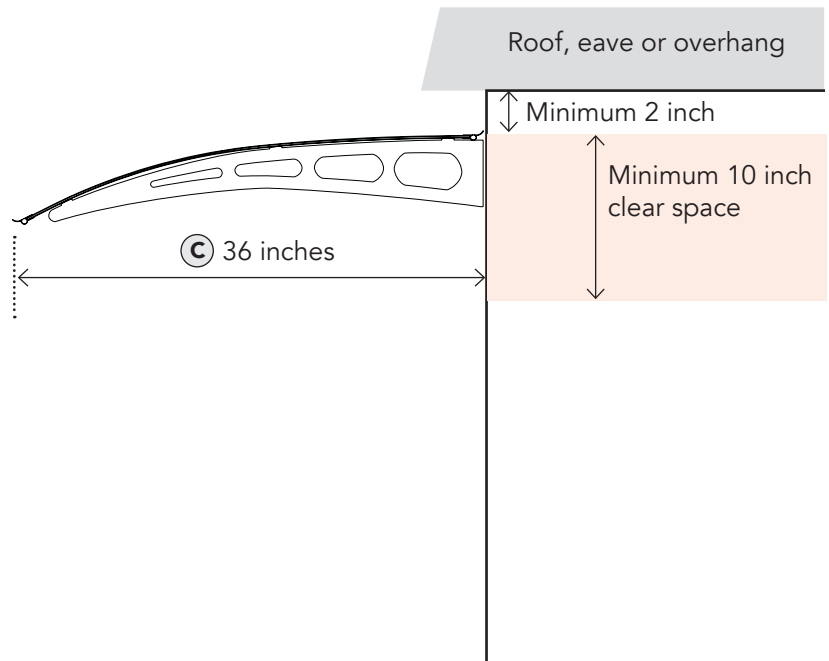

Fig 9

INSTALLATION

ASSEMBLE THE DOOR AWNING

NOTE: Polycarbonate protective film is labeled with an arrow, showing which side goes up and which side of the polycarbonate goes against the wall.

① Peel the protective film from both the top and bottom back about 2" from the front and the wall side edges of the awning sheet.

② Apply the rubber strips to the front and wall side edge of the awning sheet.

③ Trim off all excess rubber strips.

④ Press the awning bars onto the front and wall side edges of the awning sheet.

⑤ Using a small wooden block and a rubber hammer, gently tap along the entire length of the awning bars to firmly secure the bars to the awning sheet

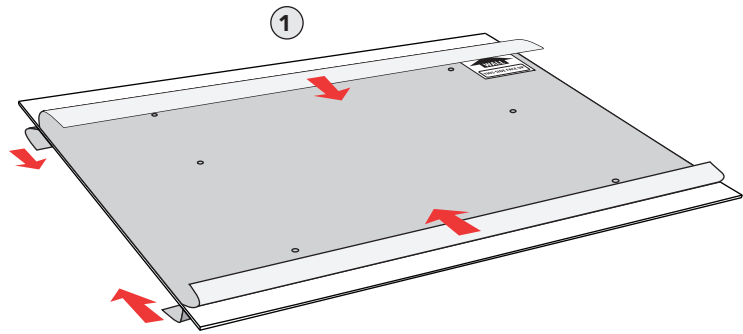

Fig 10

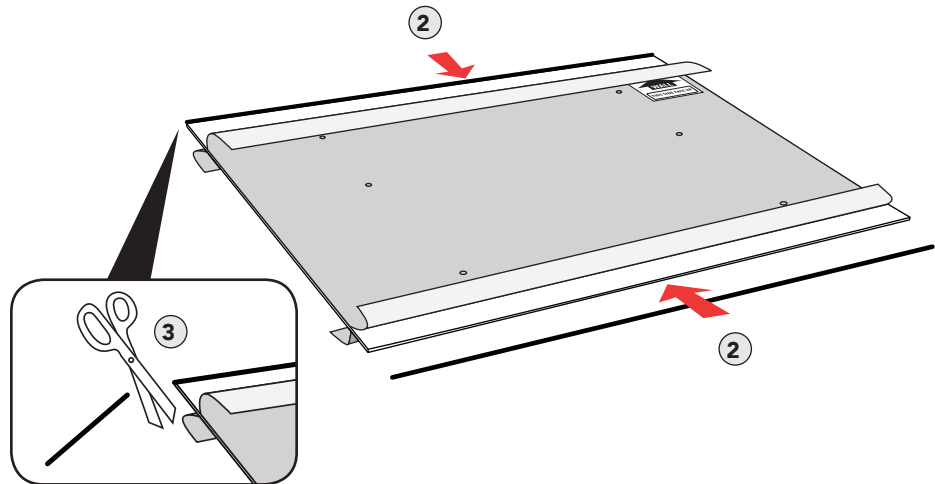

Fig 11

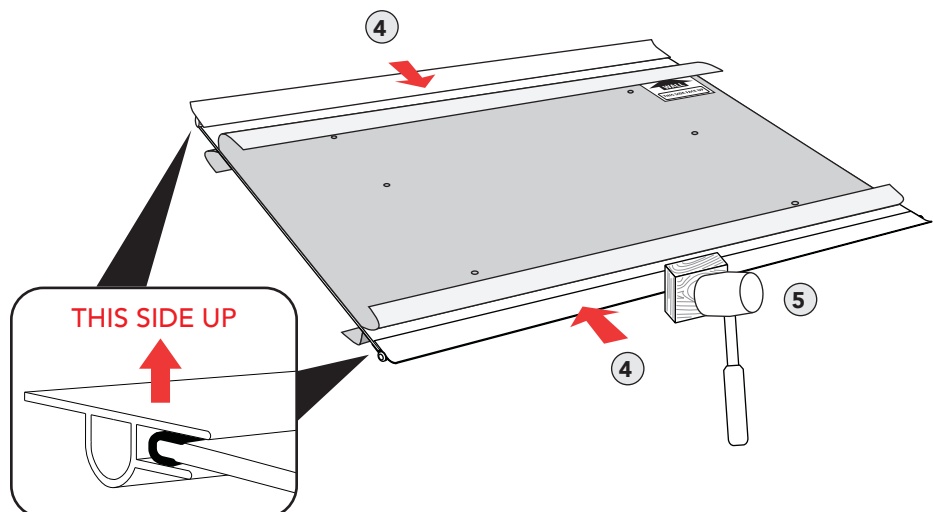

Fig 12

INSTALLATION

- 6 Peel away the protective film from both the top and bottom of the awning sheet.

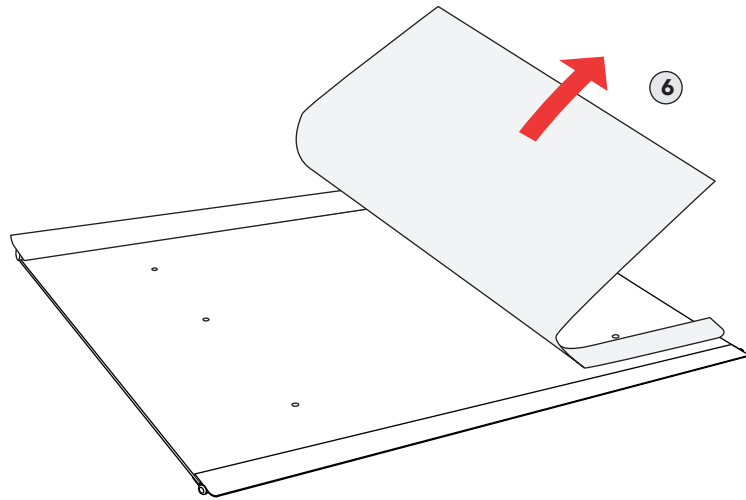

Fig 13

NOTE: For frost models, make sure the frosted side of the awning screen faces down and the shiny side faces up.

- 7 Match the holes on the awning sheet to the holes along the top of the awning brackets.

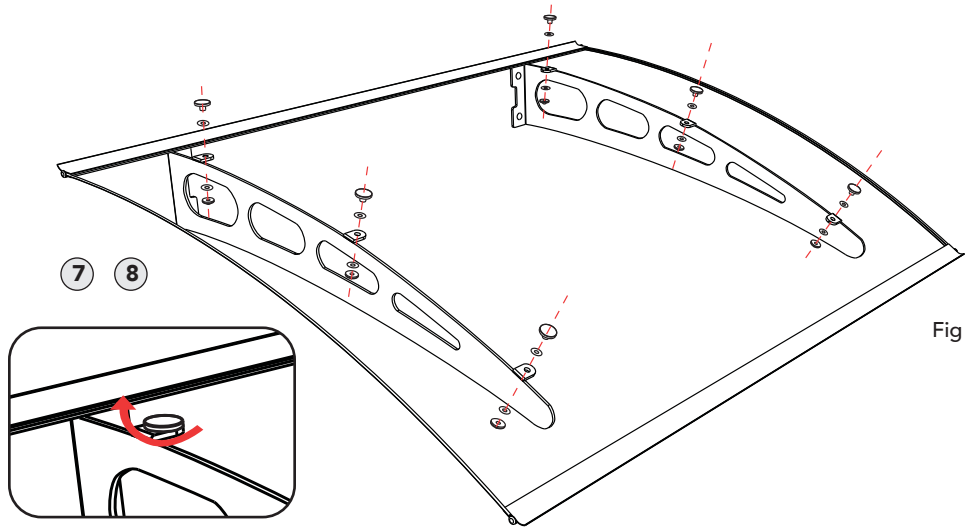

Fig 14

- 8 Secure the awning sheet to the brackets with the bracket screw sets.

- 9 **Optional step:** Apply the wall rubber strip to the wall side awning bar.

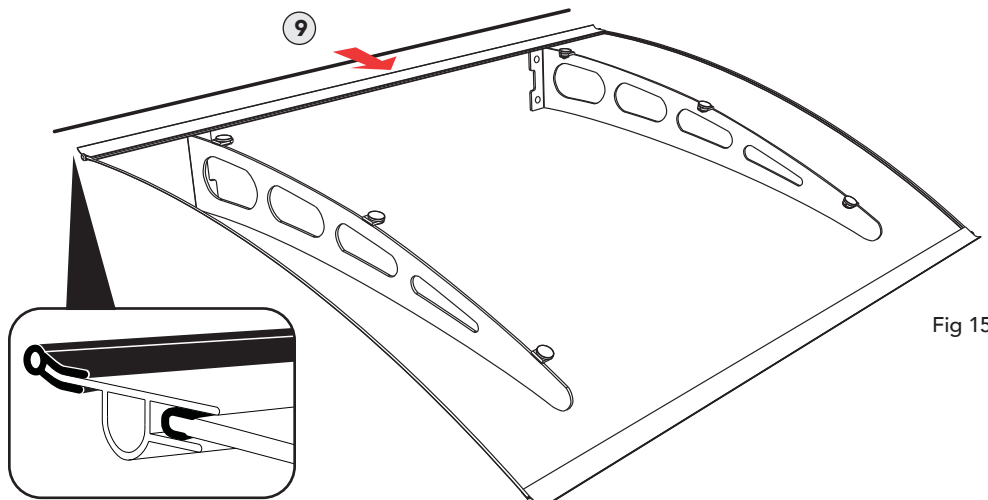

Fig 15

Models
DA7935-PSS1A &
DA9435-PSS1A skip
step 9.

INSTALLATION

INSTALL THE DOOR AWNING

It is recommended that you have a minimum of 2 people during installation

- ① Hold the assembled Door Awning in the area you want to install it and use a level to ensure that the Door Awning is leveled.

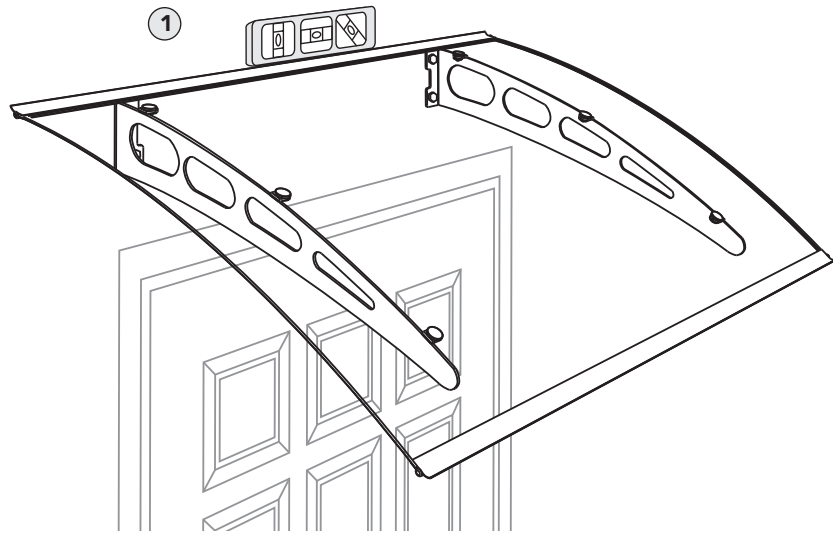

Fig 16

- ② Mark the positions of all the mounting holes through the bracket holes using a marker/pencil.

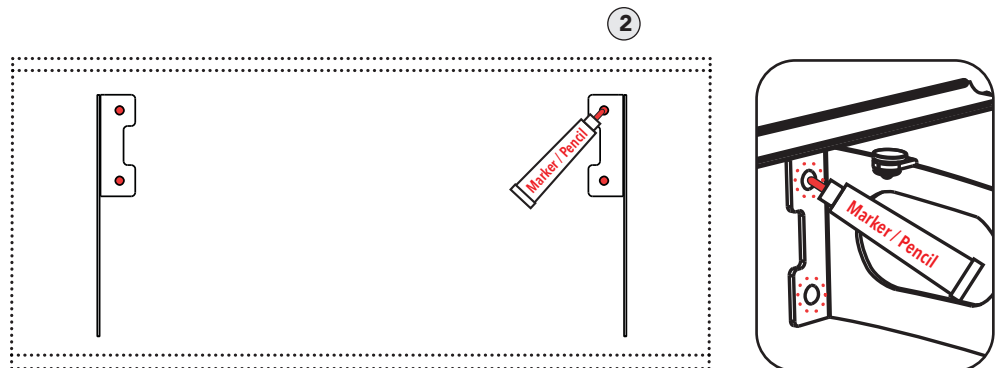

Fig 17

- ③ Drill the mounting holes using a drill bit.

CAUTION: Make sure to use the appropriate sized drill bit for the mounting screws.

Do not drill where electrical wires or gas and water pipes may exist.

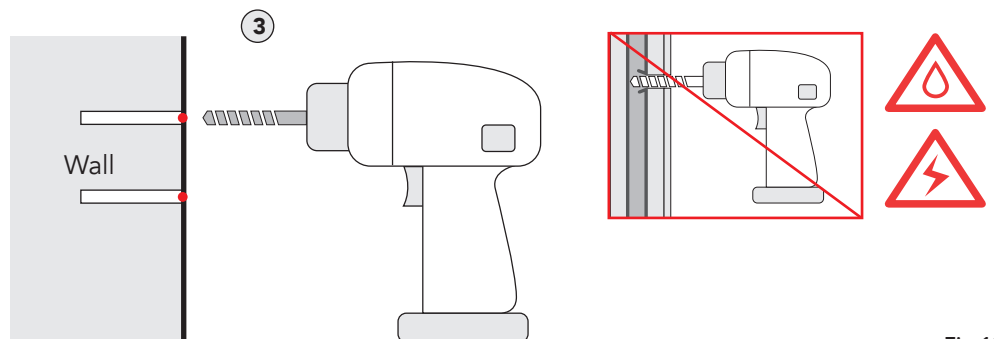
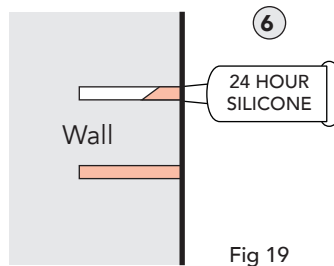

Fig 18

INSTALLATION

- 6 Fill the mounting holes with 24 hour silicone.



- 7 Place the Door Awning so that the bracket holes are aligned with the mounting holes on the wall. Insert the lag screws through the washers into the silicone filled holes.

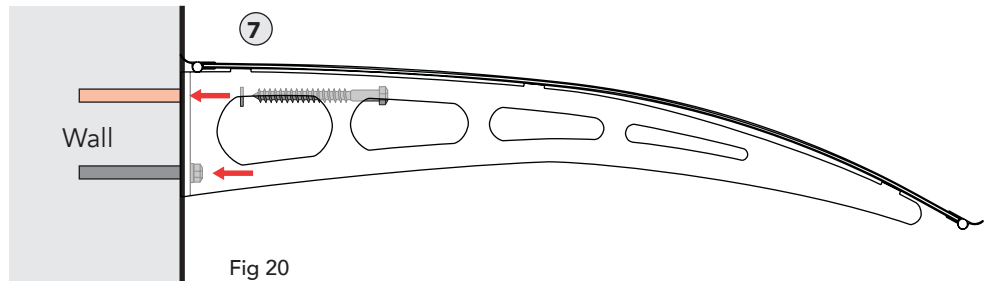

NOTE: Use a level to ensure that the awning is leveled.

- 8 Tighten the lag screws with a wrench.
- 9 Once the door awning has been securely mounted to the wall, apply 24 hour silicone around all screws to create a watertight seal.

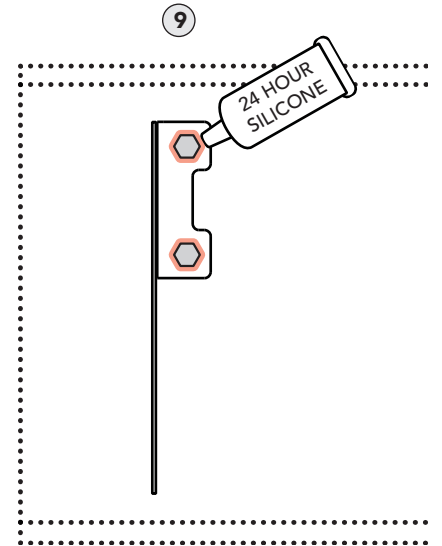
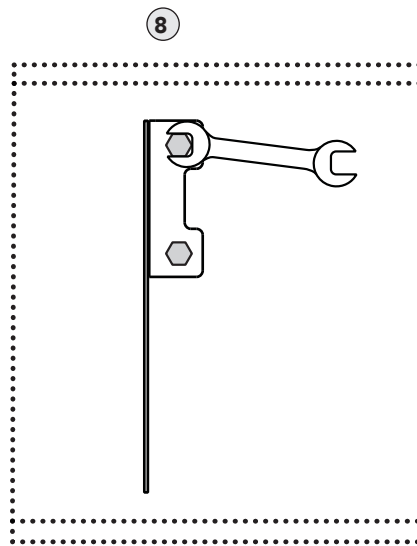

INSTALLATION

- ⑩ Apply 24 hour silicone to the wall edge of the Door Awning.

NOTE: Please allow 24 hours for the silicone to fully set.

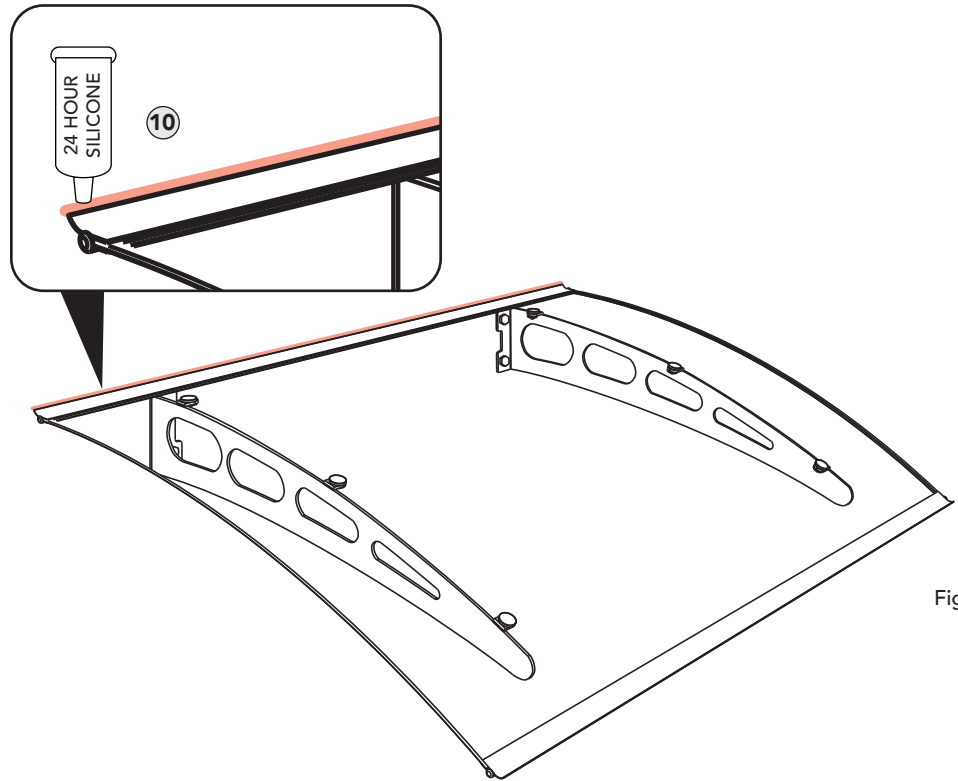

Fig 23

- ⑪ Press the screw caps onto the lag screw heads.

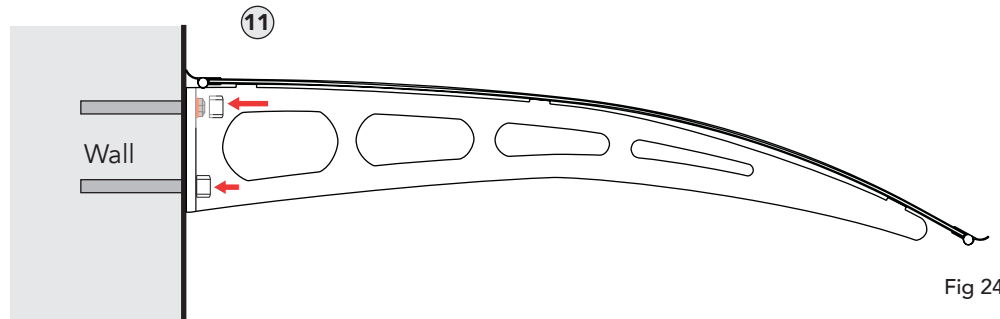

Fig 24

MAINTENANCE

CLEANING

Clean the door awning with mild detergent solution and rinse with cold clean water. Do not use acetone, abrasive cleaners or other special detergent to clean the awning sheet.

CARE AND MAINTENANCE

It is important to inspect the screws and the condition of the silicone seals. Perform periodic inspections to ensure that all the screws are properly tightened and that the silicone seals are in good conditions. Re-tighten all screws and re-apply silicone as needed to prevent water leakage.

LIMITED WARRANTY AND CUSTOMER SERVICE

LIMITED WARRANTY COVERS

Advaning warrants all Advaning original products, sold and installed within the contiguous 48 states of the United States, to be free of defects of materials and workmanship. This warranty only applies to the original owner or purchaser of the product and is only effective on a basis for twelve (12) months or one (1) years from the date of purchase. Any defects or issues presented to Advaning within the warranty period will be handled by Advaning Customer Service within a reasonable time.

Entire awning framework, including polycarbonate sheet and brackets are covered under the limited warranty. Should the purchaser notify Advaning within the twelve (12) months or one (1) year period from the date of the original purchase, defective component will be replaced in full or repaired by Advaning at no charge. Powder coated finishes and painted finishes are excluded and are NOT covered under this limited warranty.

ANY MODIFICATIONS OR ALTERATIONS TO THE PRODUCT WILL VOID THIS WARRANTY.

ADVANING, INCLUDING ITS SUBSIDIARIES AND AFFILIATES SHALL NOT BE RESPONSIBLE IN ANY MANNER WHATSOEVER FOR INJURY, DEATH OR DAMAGE TO PROPERTY AS A RESULT OF THE INTENTIONAL OR ACCIDENTAL MISUSED FOR PURPOSES FOR WHICH THE PRODUCT WAS NOT DESIGNED FOR.

WARRANTY LIMITATION AND EXCLUSION

The warranty will be in effect once the awning is fully paid for.

Advaning is not responsible for damages due to faulty modifications, installation, or re-installation.

Advaning assumes no liability for damage to the structure to which the awning is attached, or to the property located underneath the awning. This limited warranty does not cover damage from ice, snow, hail, high winds, vandalism, neglect, improper use, or any natural disasters. This limited warranty does not cover degradation due to salt corrosion, oxidation, and chipping or peeling of the paint.

Problems and Warranty Claims

If you experience a problem with your Advaning product, please contact Advaning Customer Service over the phone **Monday through Friday 8:00AM – 4:00PM Pacific Standard Time at 1-855-574-0158 or email us at service@advaning.com**.

- Prior to contacting Advaning via phone or email for warranty claims, please have your model name/ number, serial/lot number, original proof of purchase, and a description of difficulty experience ready for our Customer Service team. Most issues can be resolved over the telephone by our trained Customer Service representatives. If any issues arise that cannot be solved over the phone or email, Advaning will issue a Return Merchandise Authorization ("RMA") number, and arrange replacement parts for you.

For more information on returning a RMA product, please see Advaning Return Policy or contact Advaning Customer Service Department at (855) 574-0158.

- All Work will be carried out by Advaning or its authorized agents and will not extend the warranty coverage period beyond the twelve (12) months from the original date of purchase. Any work done by a third party or non-authorized Advaning agent will void this warranty.

THIS WARRANTY IS EXCLUSIVE AND IS IN LIEU OF ANY AND ALL OTHER WARRANTIES, EXPRESSED OR IMPLIED. NO IMPLIED WARRANTIES OF MERCHANTABILITY OR FITNESS FOR A PARTICULAR PURPOSE ARE GIVEN, ANY AND ALL LIABILITY FOR BREACH OF ANY IMPLIED WARRANTY OR WARRANTY CREATED BY LAW IS DISCLAIMED.

LIMITED WARRANTY AND CUSTOMER SERVICE

Some states do not allow limitations on how long an implied warranty lasts, so the above limitation may not apply to you.

UNDER NO CIRCUMSTANCES SHALL ADVANING, INCLUDING ITS SUBSIDIARIES AND AFFILIATES BE LIABLE FOR INCIDENTAL OR CONSEQUENTIAL DAMAGES WITH RESPECT TO ECONOMIC LOSS, INJURY, DEATH OR PROPERTY DAMAGE, WHETHER AS A RESULT OF BREACH OF THIS WARRANTY, NEGLIGENCE OR OTHERWISE.

Some states do not allow the exclusion or limitation of incidental or consequential damages, so the above limitation or exclusion may not apply to you in whole or in part. This warranty gives you specific legal rights. You may also have other rights that vary from state to state.

What is Not Covered by the Advaning Limited Warranty

This warranty is non-transferable and does not cover product purchases from the initial buyer to a third party. This warranty does not cover incidental damages, such as loss of time, loss of use, or installation costs of defective, repaired or replaced product. This warranty does not cover product that has been damaged or rendered defective as a result of:

- (a) Neglect, abuse or misuse.
- (b) Modification of the original product.
- (c) Improper use or installation using products not manufactured by Advaning.
- (d) Service provided by anybody other than Advaning.
- (e) Abnormal mechanical or environmental conditions.
- (f) Unusual physical or electrical stress -including failure or fluctuation of electrical power, lighting, static electricity, fire, tornadoes, or other natural disasters.

Shipping Damage Claim:

On the occasion of a damage claim, the end user must contact Advaning and the delivering freight carrier within 3 days of signing for the delivery in order to make a claim. Failure to report freight damage and missing parts in a timely manner and in accordance to the carrier's guidelines may result in you incurring all costs.

Likewise, there are 7 days to report missing parts to Advaning.

For more information, please contact the corporate office.

Advaning Customer Service Center
Toll Free (US): (855) 574-0158
Email: service@advaning.com
Monday through Friday 8:00 am to 4:00 pm (Pacific Standard Time)

**CONTACT
INFORMATION**

Service Questions: service@advaning.com
Toll Free (US): 855-574-0158

12282 Knott Street, Garden Grove, CA 92841

www.advaning.com