

# ASSEMBLY INSTRUCTIONS

## DESCRIPTION: MIRROR & DRESSER

**Caution:** Please read instructions thoroughly before unpacking assembly parts. Sharp, exposed staple tips can cause injury, therefore, for your protection, please remove any exposed staple used in packing.

1. We recommend that you should assemble this product with the assistance of another person; this will make assembly easier, and will help to eliminate damage to the product or injury to persons during assembly.
2. Be sure to check all packing materials carefully for small parts that may have come loose inside the carton during shipment.
3. please do not over tighten screws or bolts.
4. Please put all parts on a non-abrasive floor before assembly, and follow the assembly steps to assemble your newly purchased product correctly and efficiently.

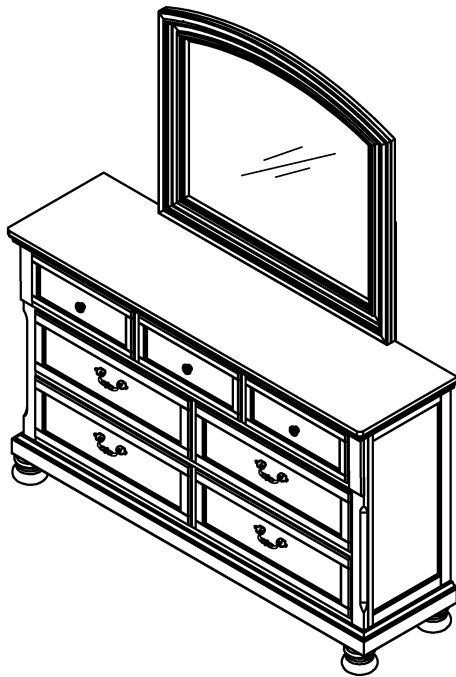

### PART LISTS

NO.	DESCRIPTION	SKETCH	Q'TY
(1)	BASE		1PC
(2)	MIRROR		1PC
(3)	LEG		4PCS
(4)	ADJUST LEVEL LEG		1PC
(5)	BACK LINK		2PCS

### HARDWARE PACK

NO.	DESCRIPTION	SKETCH	Q'TY
a	ALLEN BOLT (Ø1/4*38mmL)		8PCS
b	LOCK WASHER (Ø1/4)		8PCS
c	FLAT WASHER (Ø1/4)		8PCS
d	ALLEN KEY (4mm)		1PC
e	ANTI-TIPPING		1PC
f	L BRACKET		2PCS
g	SHORT SCREW		1PC
h	LONG SCREW		1PC

### STEP 1

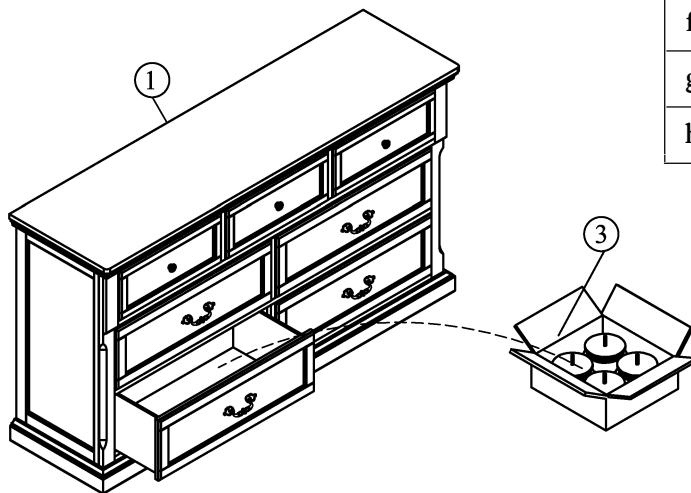

# ASSEMBLY INSTRUCTIONS

DESCRIPTION: MIRROR & DRESSER

**Caution:** Please read instructions thoroughly before unpacking assembly parts. Sharp, exposed staple tips can cause injury, therefore, for your protection, please remove any exposed staple used in packing.

1. We recommend that you should assemble this product with the assistance of another person; this will make assembly easier, and will help to eliminate damage to the product or injury to persons during assembly.
2. Be sure to check all packing materials carefully for small parts that may have come loose inside the carton during shipment.
3. please do not over tighten screws or bolts.
4. Please put all parts on a non-abrasive floor before assembly, and follow the assembly steps to assemble your newly purchased product correctly and efficiently.

## STEP 2

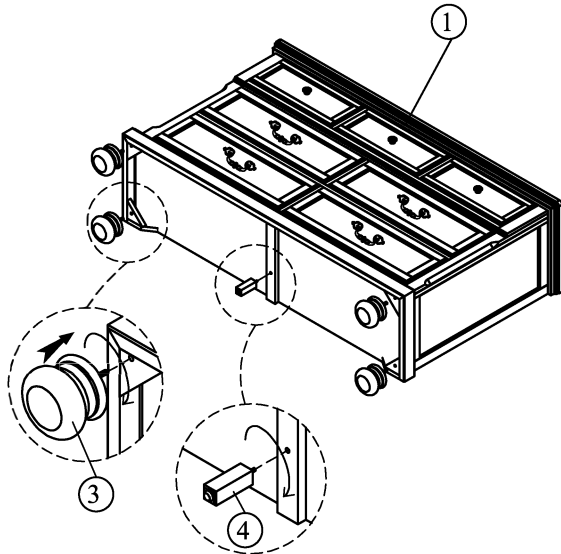

## STEP 3

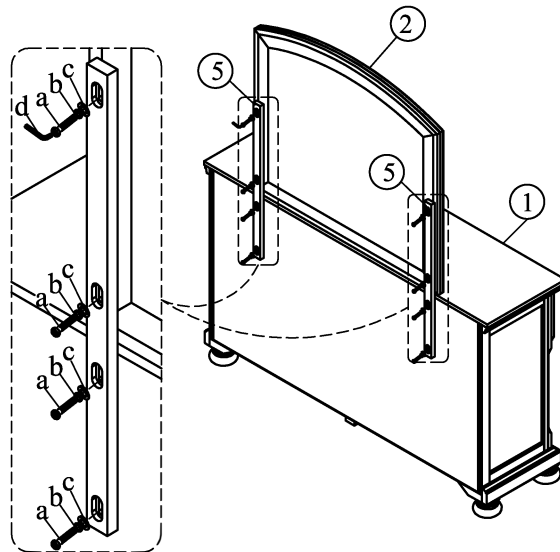

## STEP 4

