

**ASSEMBLY INSTRUCTIONS**  
Three Drawer Base Cabinet

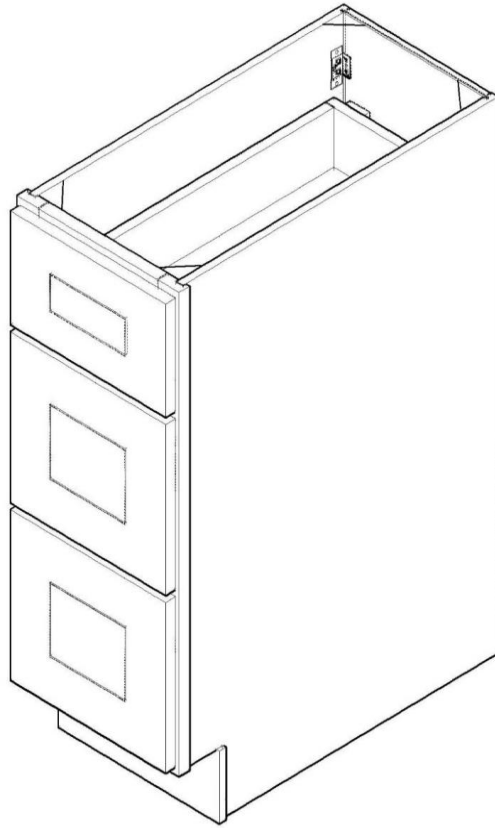

ASSEMBLY INSTRUCTIONS

### Unpacking Precautions

If using a sharp object to unpack the cabinet components and the packing materials, be careful to avoid scratching or damaging the cabinet components. The various packing materials may be used to protect the cabinet components during assembly. During the unpacking process, place the various components away from and to the side of the work area so that they will not be inadvertently knocked over or otherwise damaged.

### Base Cabinet Model Variations

These assembly instructions include all the steps required to assemble a Base Cabinet with a Shelf and Drawers. However, they can also be used to assemble a Sink-type Base Cabinet with a Shelf (skip the steps covering assembly of the drawers and installation of the rails and rail holders). The illustrations included in these assembly instructions are based on the Base Cabinet with a Shelf and Drawers.

#### Required tools

Phillips screwdriver  
Rubber mallet  
Wood Glue



#### Hardware Considerations/Screw Size Clarification

(I) (Small 1/2")

(J) (Medium 1")

(K)(Large 1 1/8")



**Step 1:**

Lay the face frame with doors (A) on a soft surface, doors facing down.

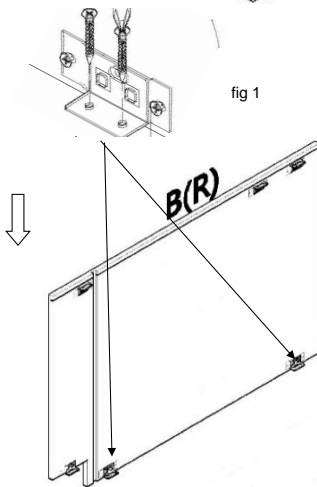
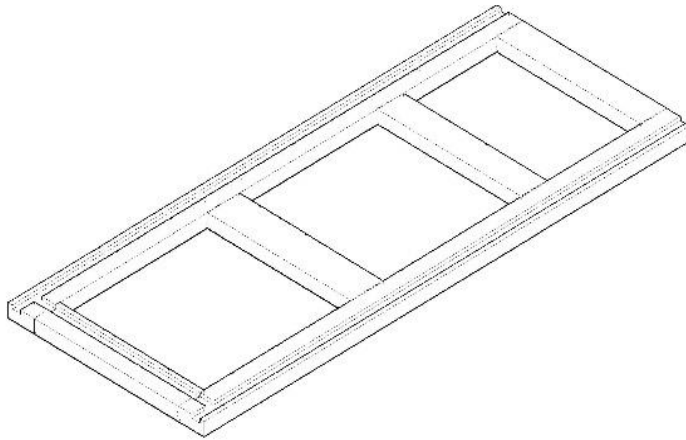

**Step 2:**

Using the wood glue, squeeze a small bead of glue in all grooves before assembling the cabinet sides, bottom, top and back panels. Be careful not to use too much glue, this could cause excess glue to squeeze out and onto the panels. If this should happen, be sure to remove quickly.

Slide the Right Side panel (R) in the groove of the face frame, and mount the male clip to the face frame with the screw driver. Each male clip will need 2 Small screws(I). fig 1

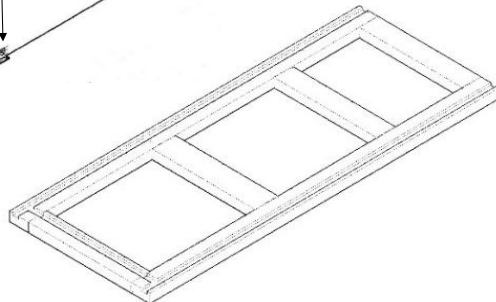

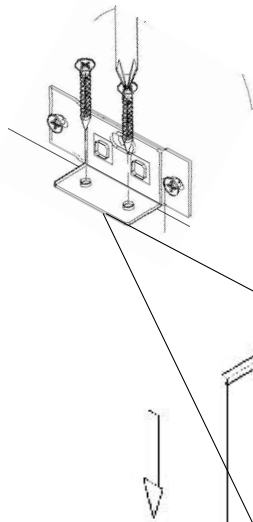

**Step 3:**

Slide the Left Side panel (L) in the left groove of the face frame, and mount the male clip to the face frame with the screw driver. Each male clip will need 2 small crews(I).

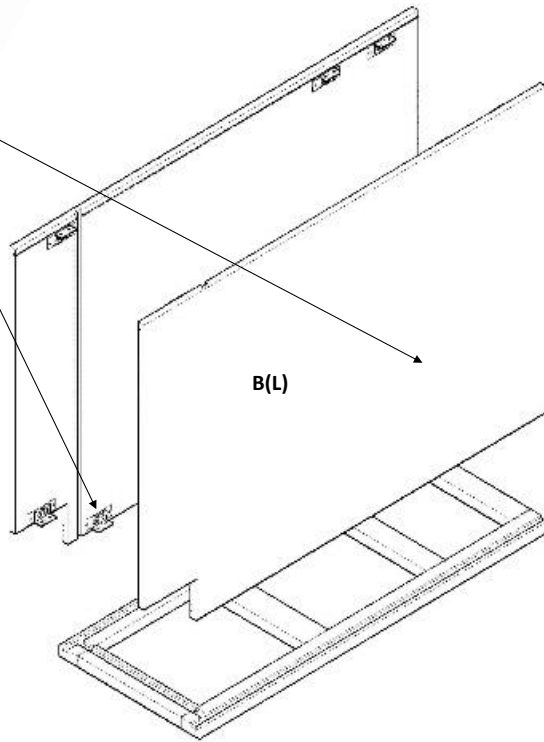

**Step 4:**

Slide bottom panel (B) into the grooves of the right and left side panels, and then into the groove in the frame below until it is fully seated.

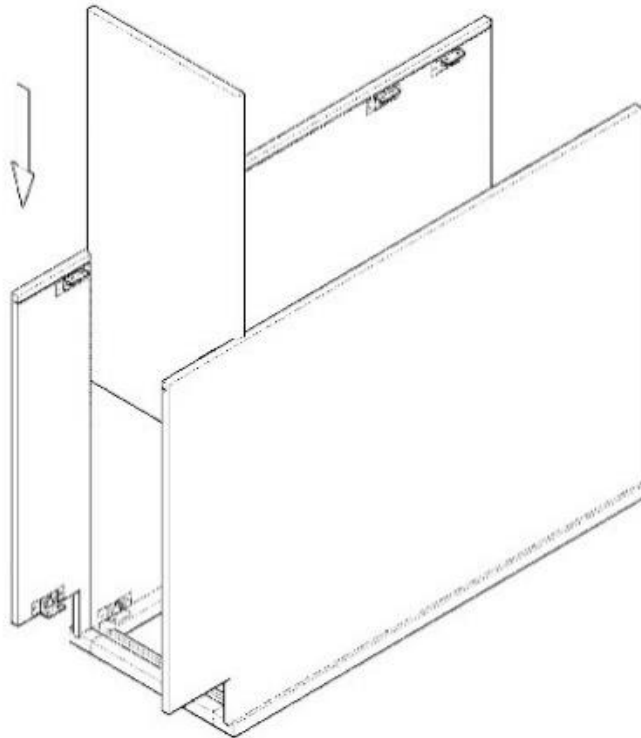

**Step 5:**

Slide in the Back panel and attach the male clips to the back panel. There're three clips on the left side and three clips on the right side. Each male clip will need 2 small crews(l).

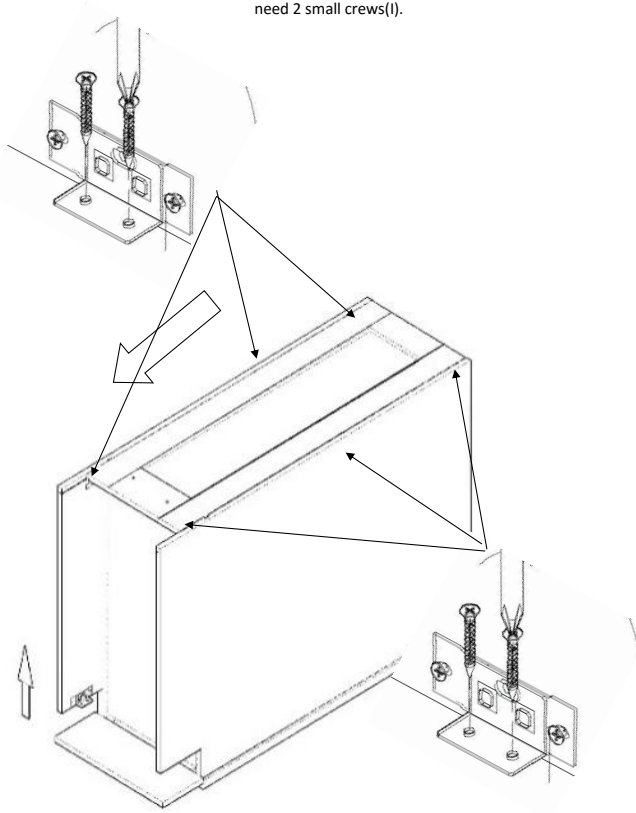

**Step 6:**

Use the Long Screws (K), and the pre-drilled holes , to attach the back panel to the edges of the bottom panel.

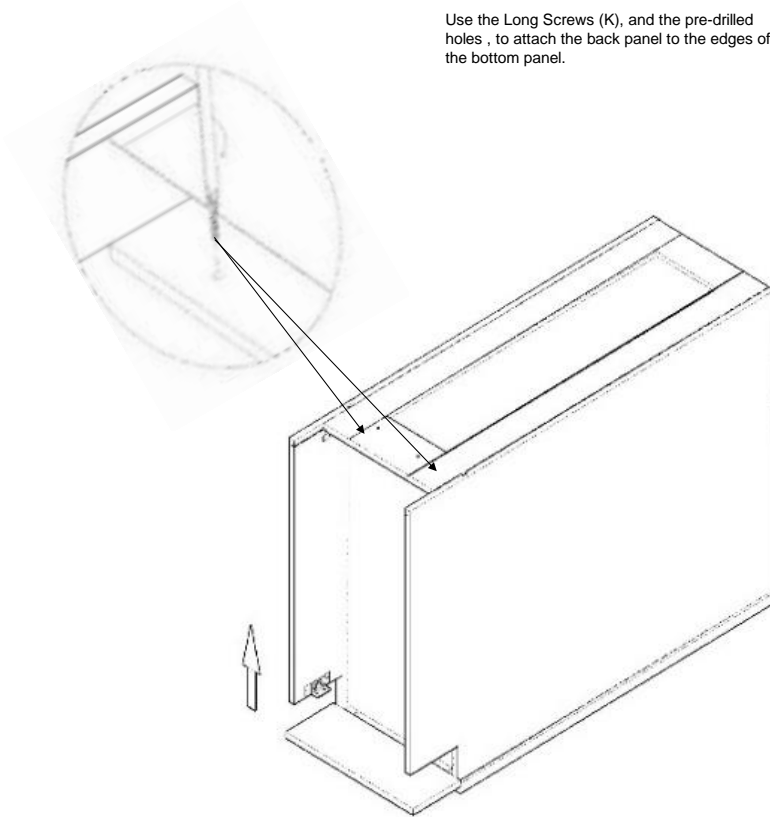

**Step 7:**  
Secure the toe kick into the bottom of the cabinet (using two small screws(!) in each of the two clips)

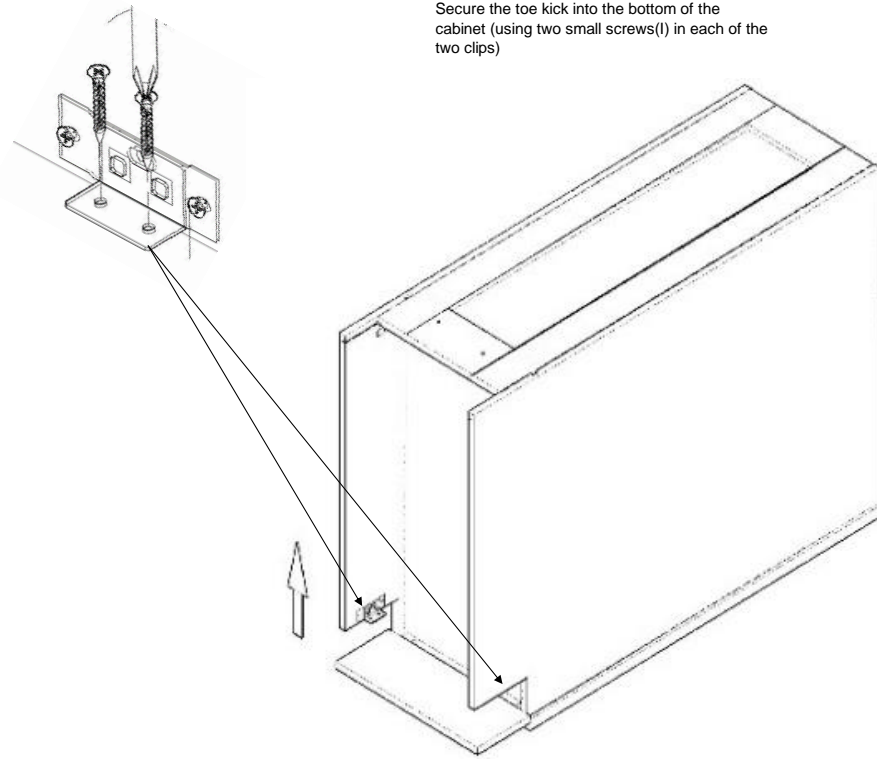

**Step 8:**  
Take the drawer glides from the carton and separate the bottom and interior glides into left & right sets.

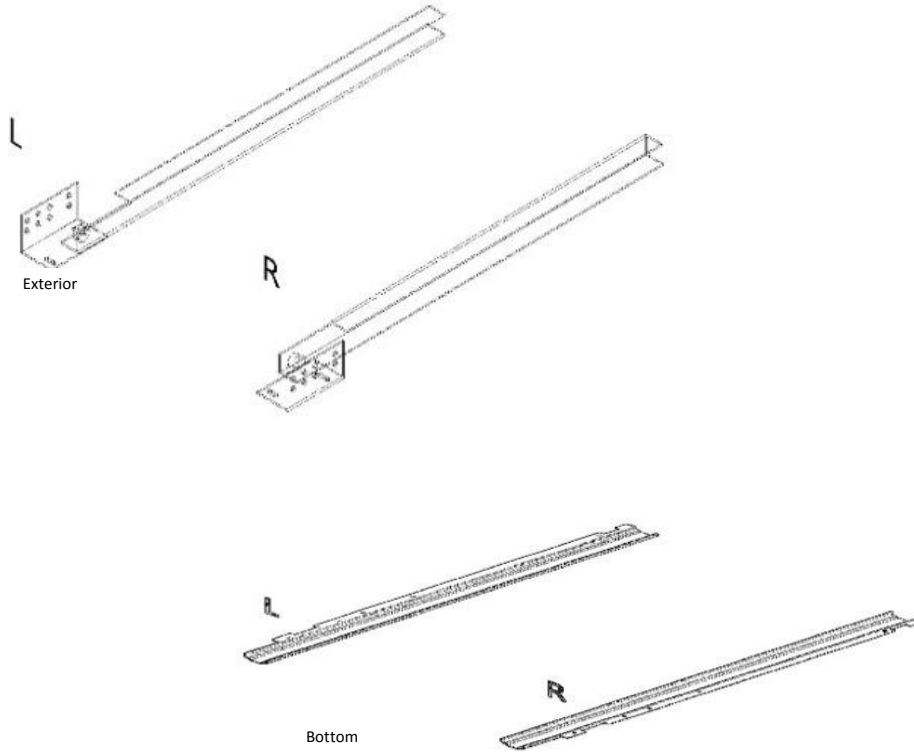

**Step 9:**

Using one small screw attached the glide brackets to the interior sets of pre-drilled holes on the back panel.  
Optional Holes: Exterior two sets are optional for soft-closing drawer glide.

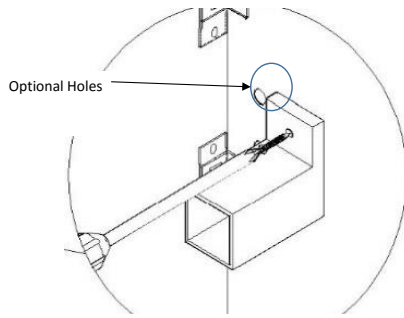

**Step 10:**

Using two small screws to attach both the left and right exterior drawer glides to the interior edge of the face frame left & right for each drawer.

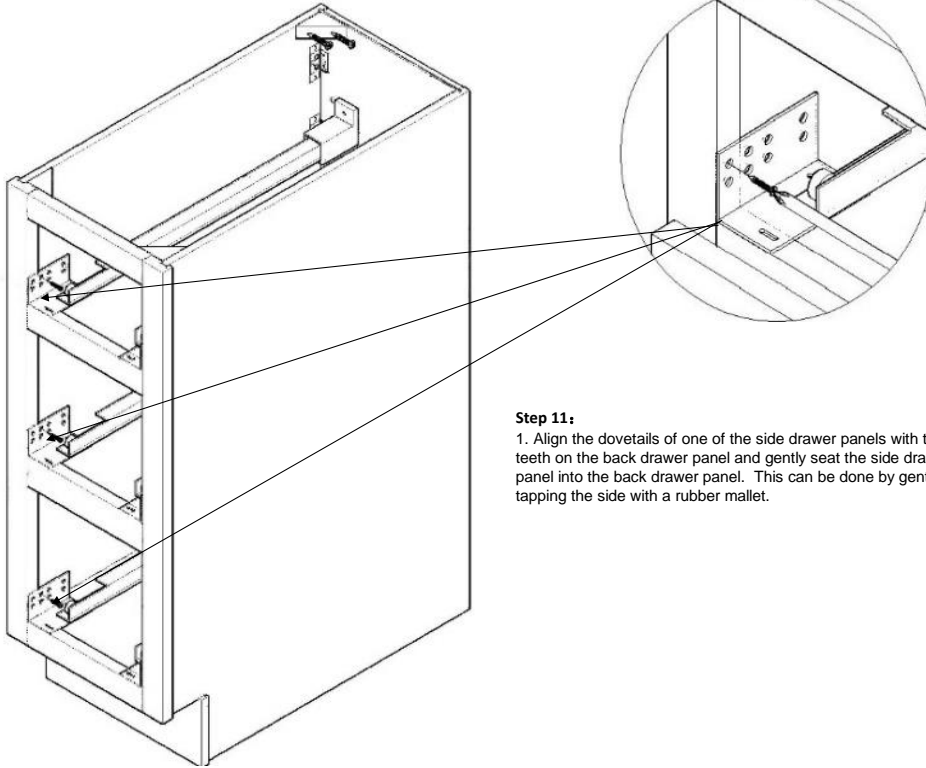

**Step 11:**

1. Align the dovetails of one of the side drawer panels with the teeth on the back drawer panel and gently seat the side drawer panel into the back drawer panel. This can be done by gently tapping the side with a rubber mallet.

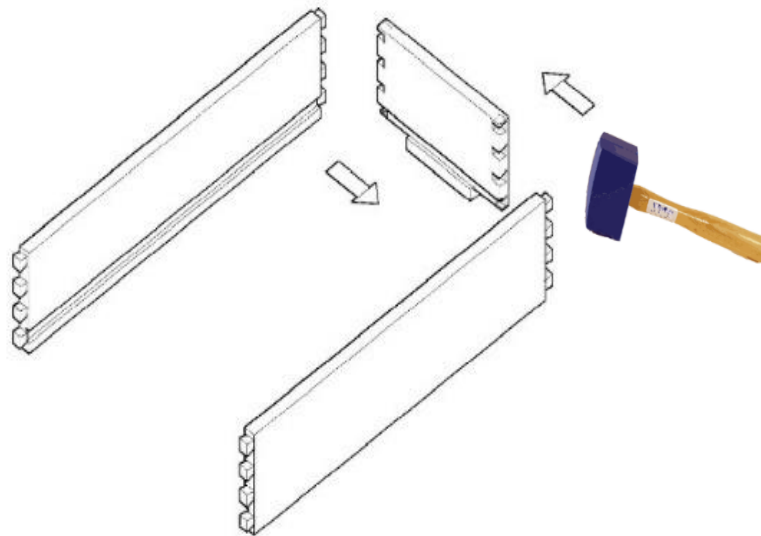

**Step 12:**

Slide the drawer bottom into the grooves in the sides and back drawer panels until it is fully seated.

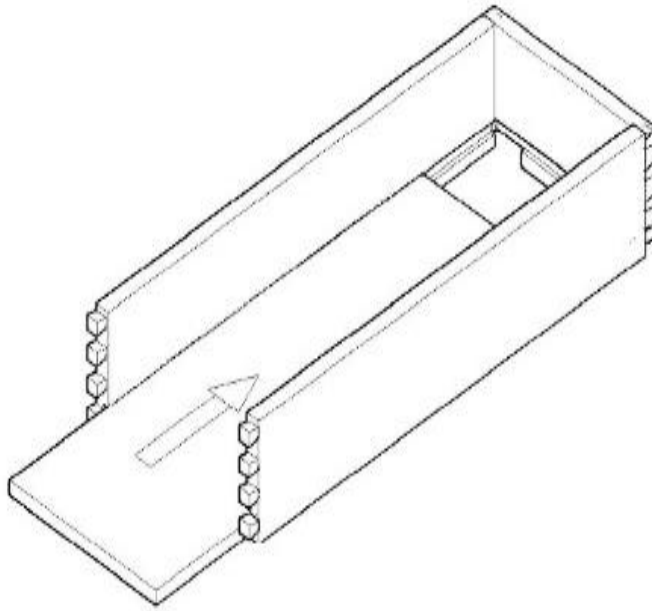

**Step 13:**

Attach the drawer fronts to the drawer box by aligning the dovetails of drawer panels with the teeth on the front drawer panel and gently seat as above.

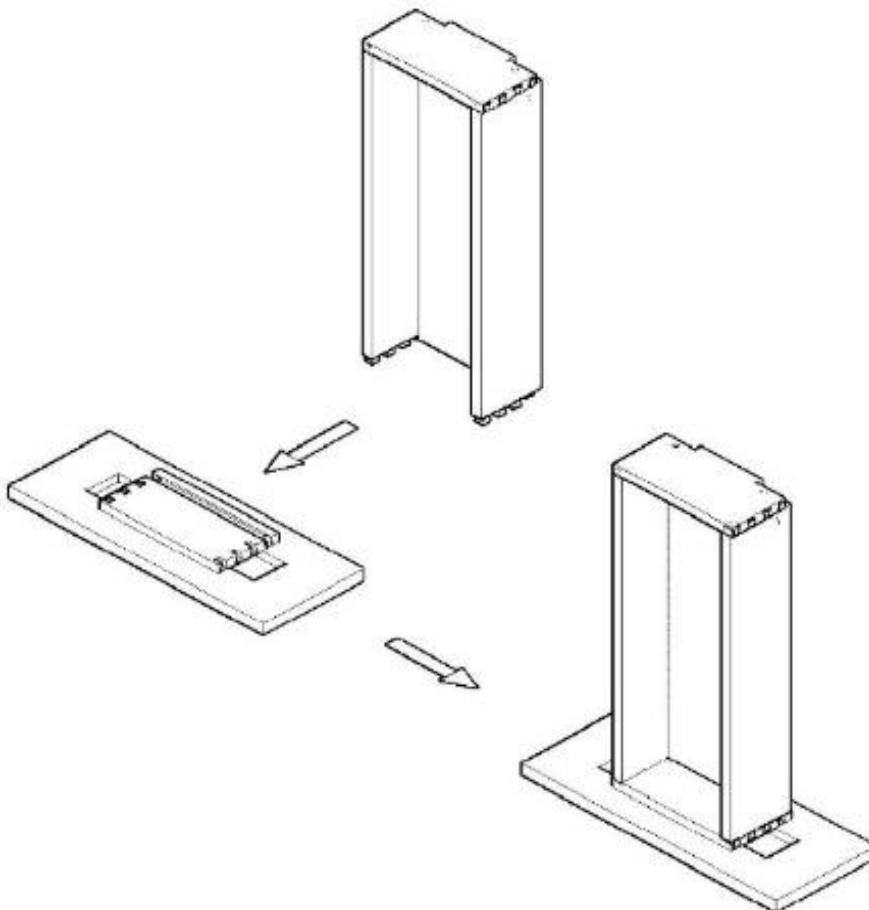

Turn the drawer  
box over

**Step 14:**

Attached the bottom drawer glides using the small  
screws(l) three on each side.

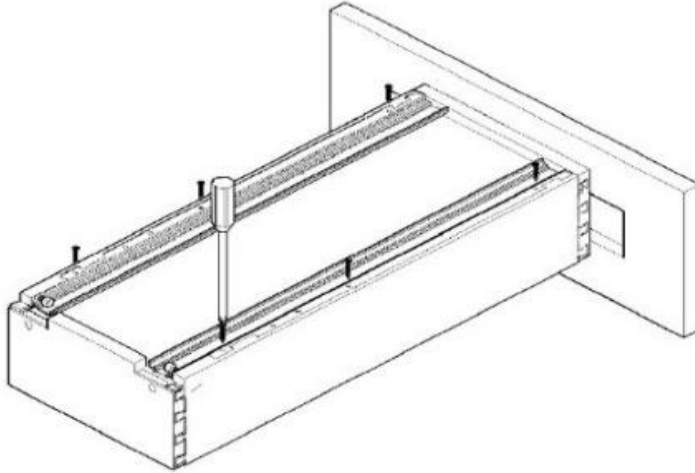

**Step 15:**

Install the drawers into the cabinet by aligning the bottom  
glides with the exterior glides in the cabinet.

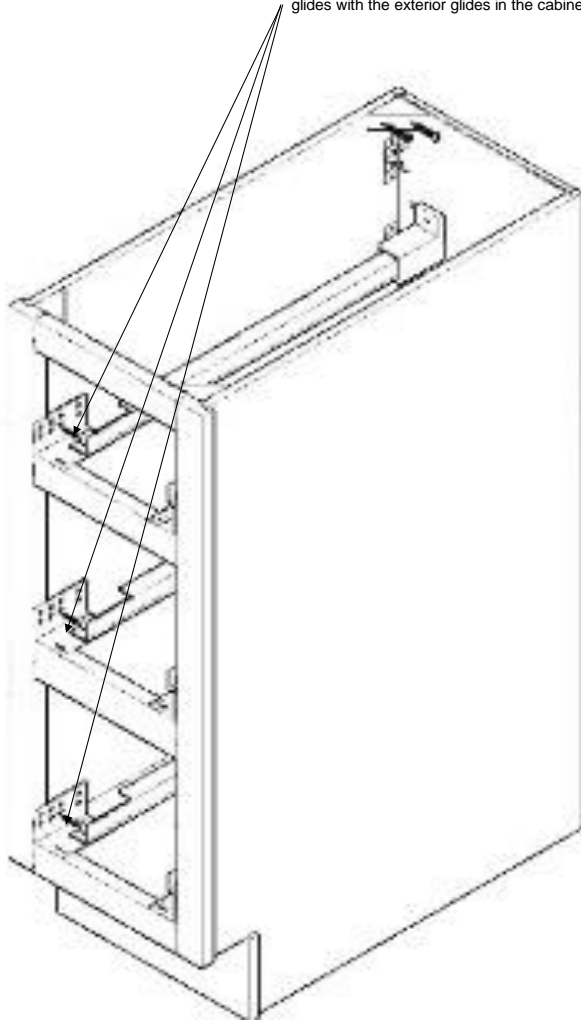



**Step 16:**

Use Two middle size screws(J) to attach 4 wooden triangle blocks in all four corners of the top of the cabinet.

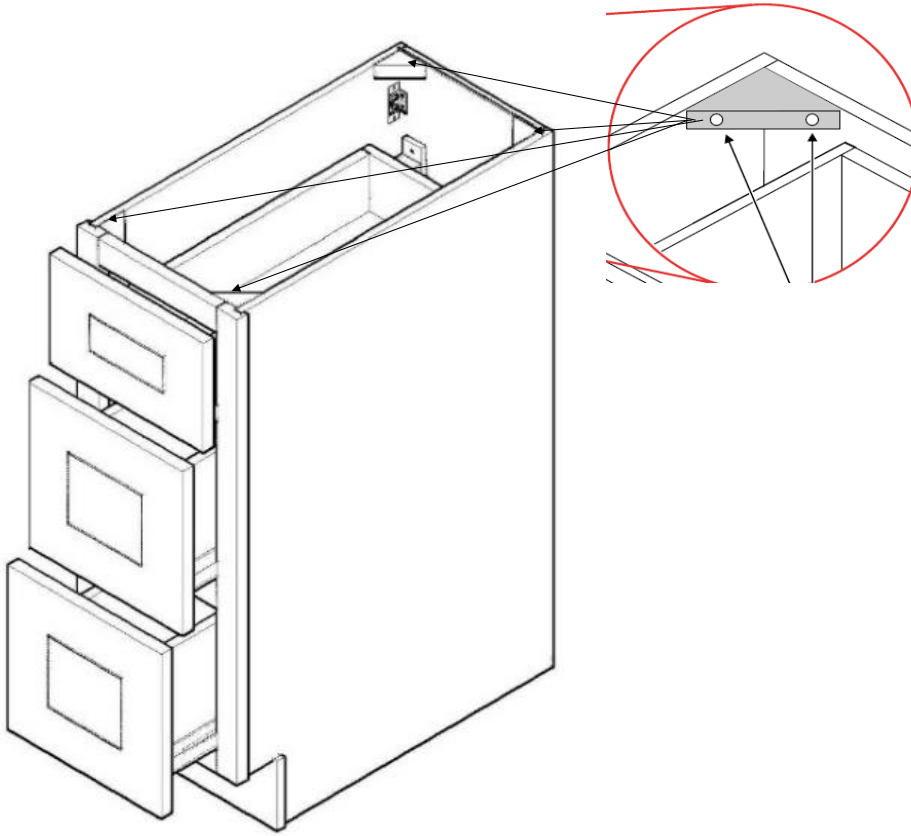

**Step 17 :**

Attached rubber bumpers to both the top corners of each drawer.

