

CAUTION:When tightening the screws,tighten sequentially.Do not tighten any screws fully and then towards the next one.When every part is OK, then tighten all the screws.





PLEASE BE CAREFUL DO NOT DAMAGE THE HOLE POSITION WHEN YOU USE POWER TOOLS !



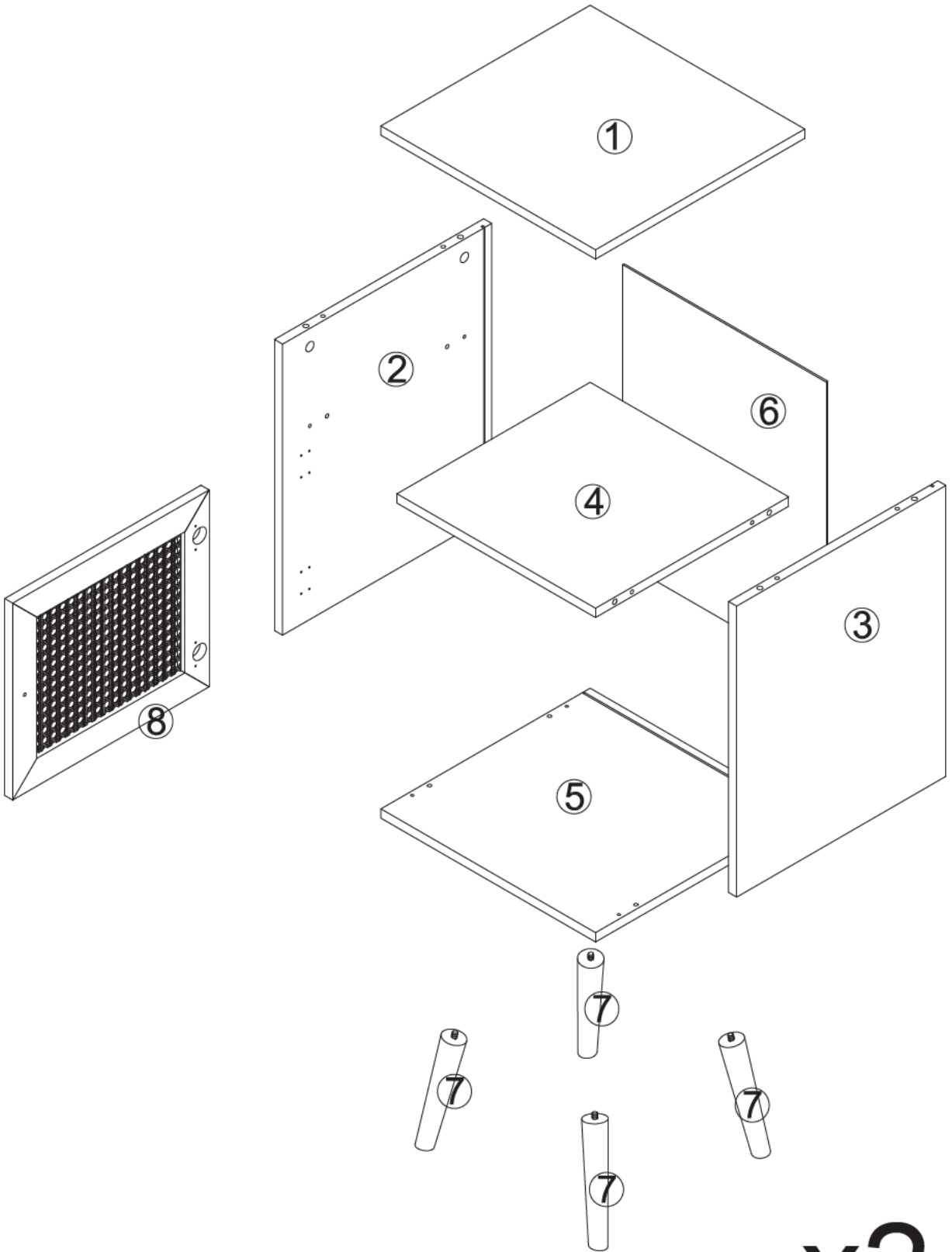



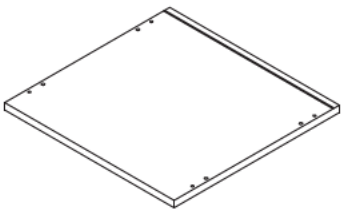
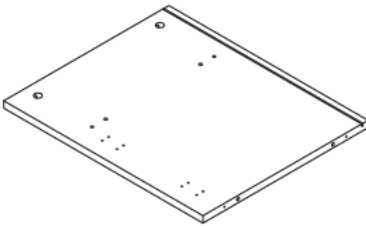
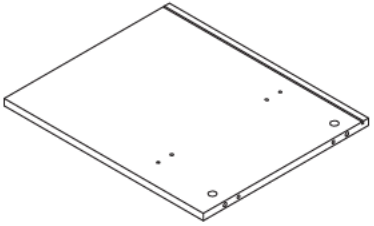
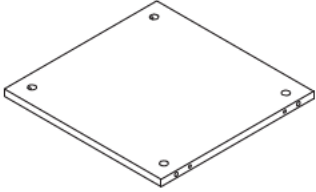
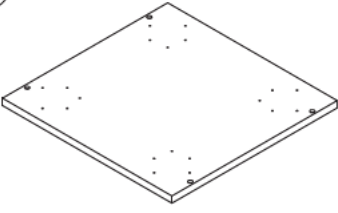
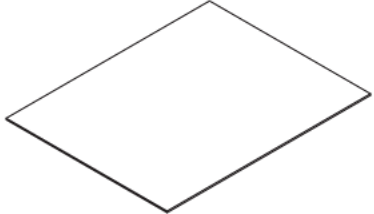

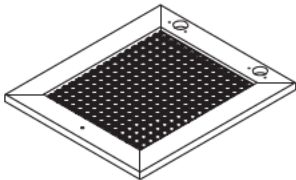

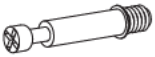



If there are any missing parts, please contact us, and we will send you a brand new replacement.

We also offer an exclusive one-month service where we provide product replacements without the need for repairs, as long as the damage is not caused by human error.



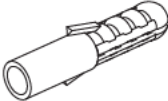

x2

| | | |
|--|--|---|
| <p>① x2</p>  | <p>② x2</p>  | <p>③ x2</p>  |
| <p>④ x2</p>  | <p>⑤ x2</p>  | <p>⑥ x2</p>  |
| <p>⑦ x8</p>  | <p>⑧ x2</p>  | |

| | | | |
|--|---|---|--|
| <p>A X8(+1)</p>  <p>Ø6x35mm</p> | <p>B X8(+1)</p>  <p>Ø15x10mm</p> | <p>C X12(+1)</p>  <p>Ø6x30mm</p> | <p>D X21(+2)</p>  |
| <p>E X5(+1)</p>  <p>Ø4x35mm</p> | <p>F X4</p>  | <p>G X8(+1)</p>  <p>Ø3x16mm</p> | <p>H X8(+1)</p>  |
| <p>I X1</p>  | <p>J X1</p>  | <p>K X4</p>  | <p>L X2</p>  |
| <p>M X12(+1)</p>  | <p>N X1</p>  | <p>O X1</p>  | <p>x2</p> |

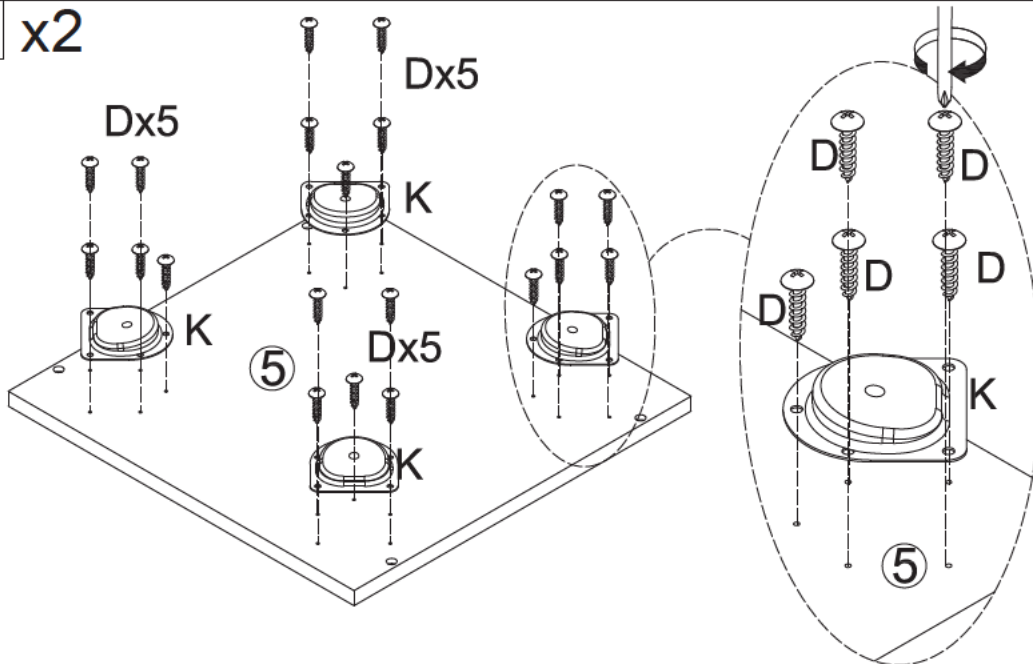
3 x2



| |
|---|
| D x40 |
|  |
| K x8 |
|  |

4 x2

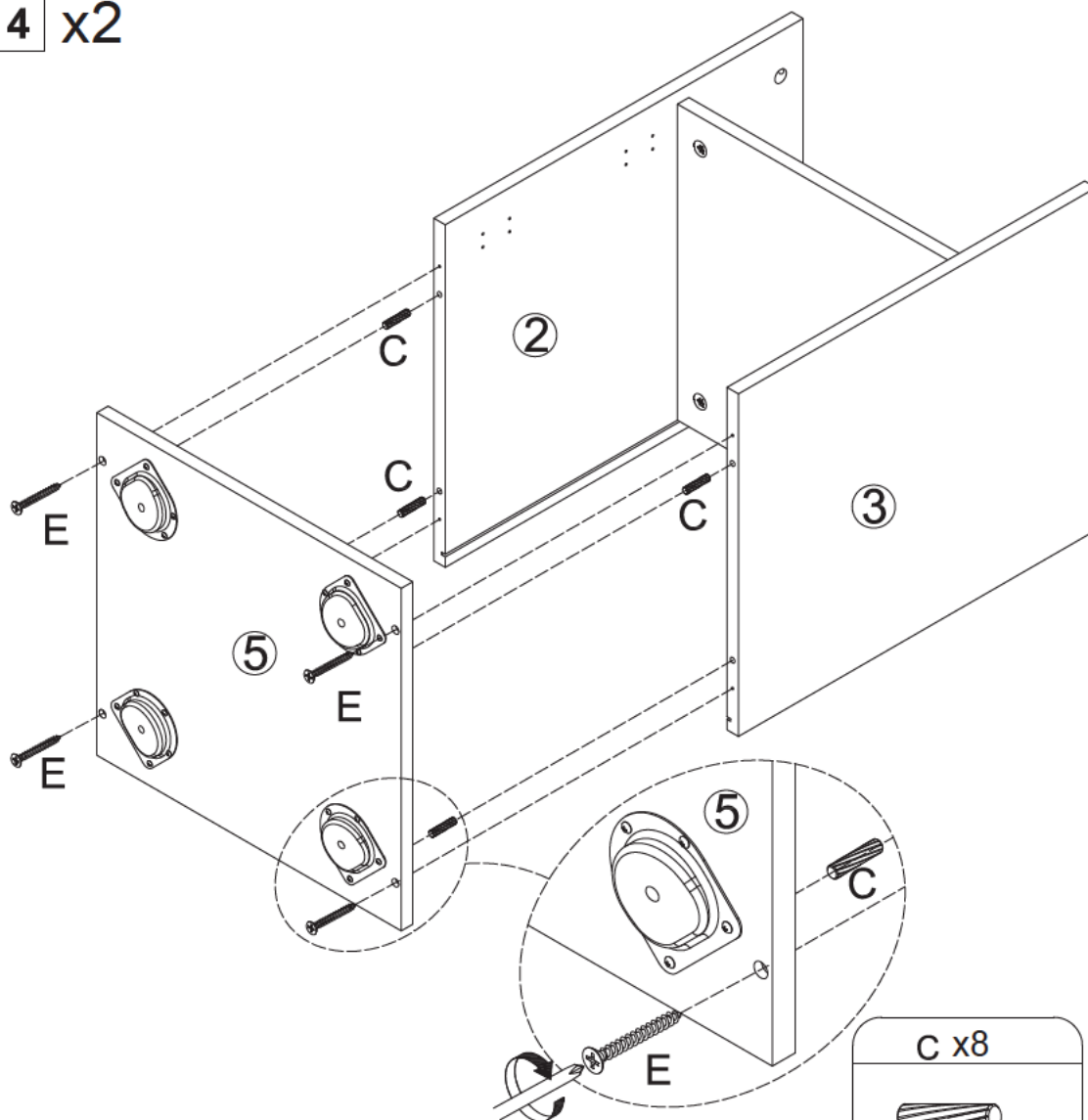

| |
|---|
| C x8 |
|  |
| Ø6x30mm |

| |
|---|
| E x8 |
|  |
| Ø4x 35mm |

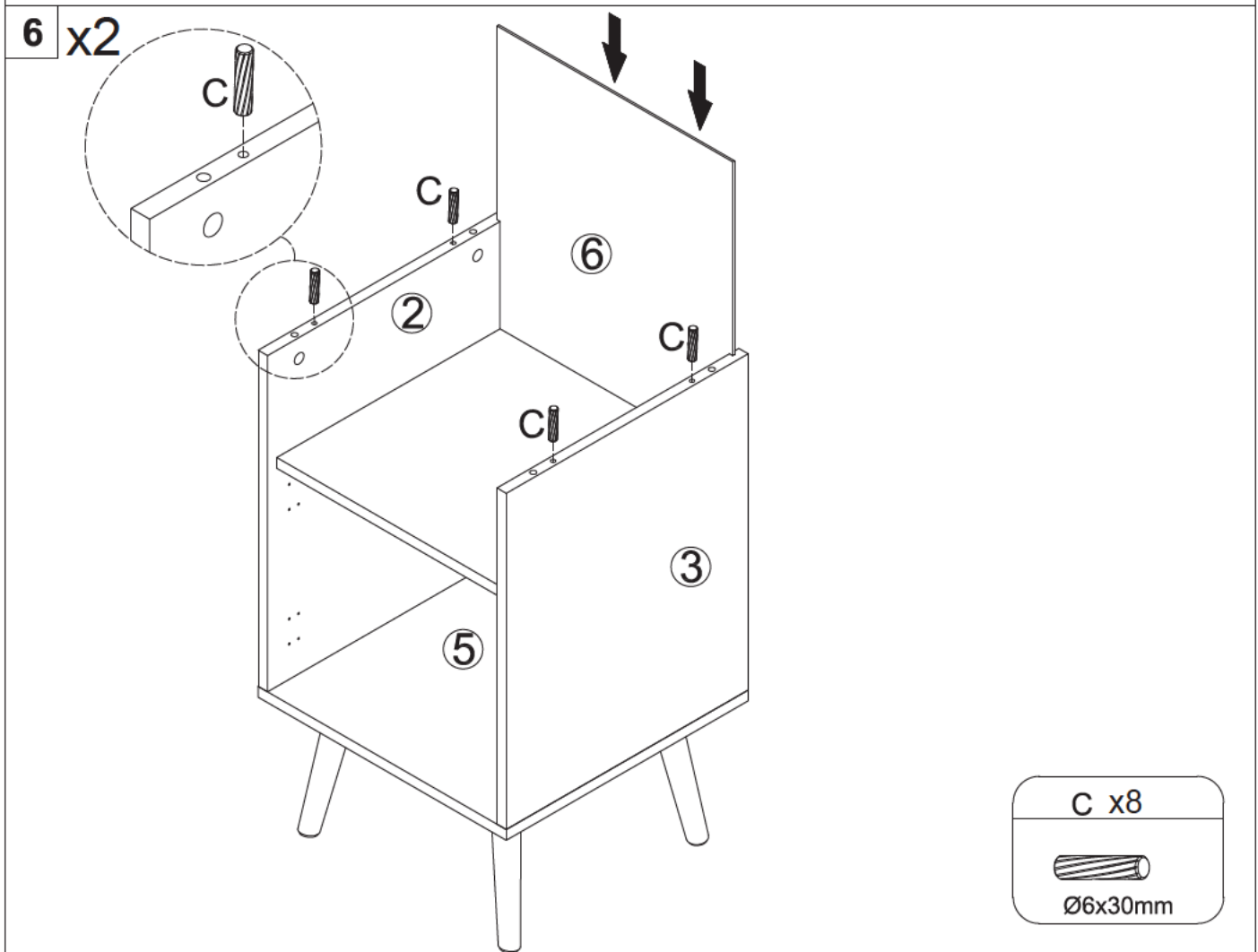
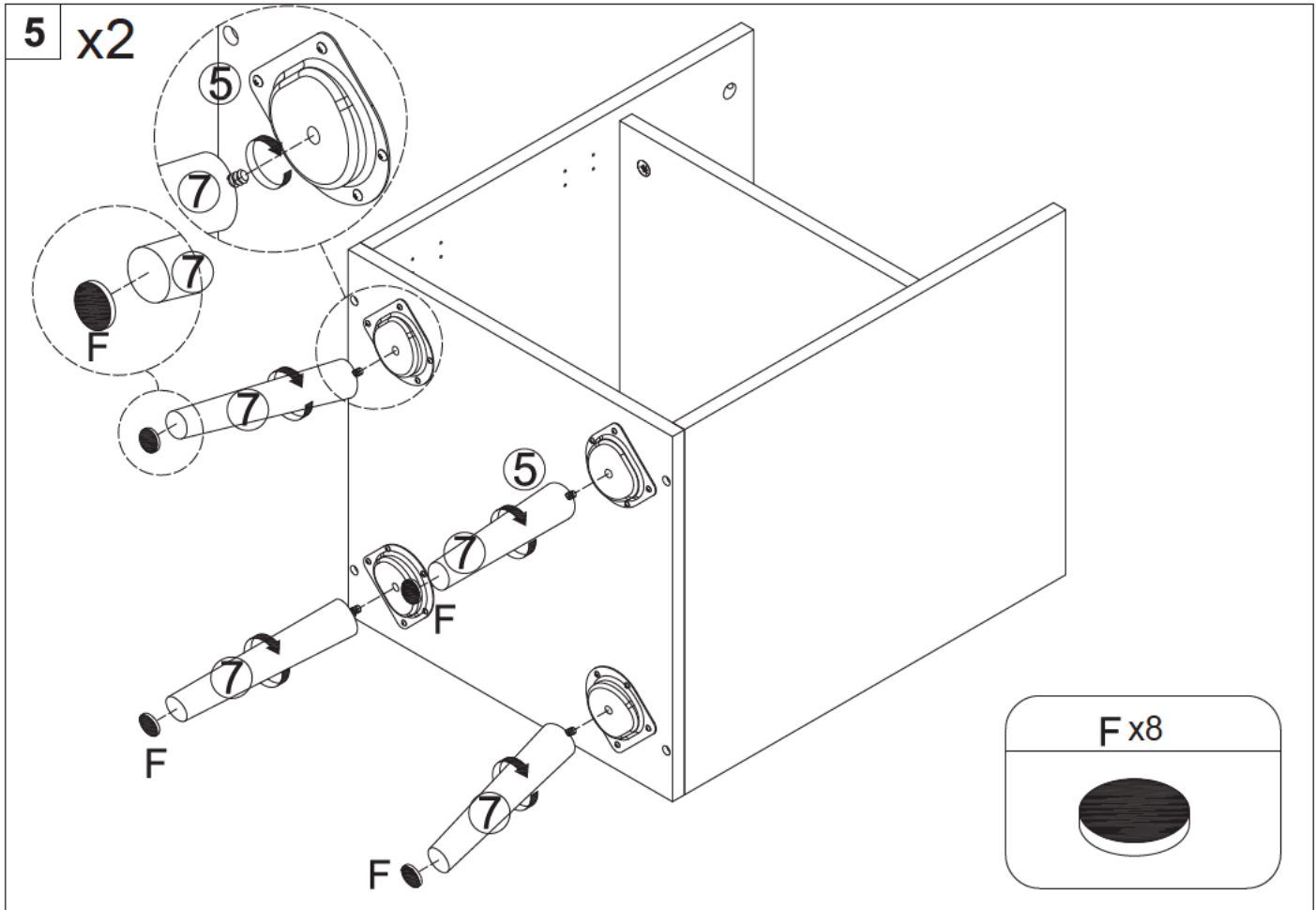

7 x2

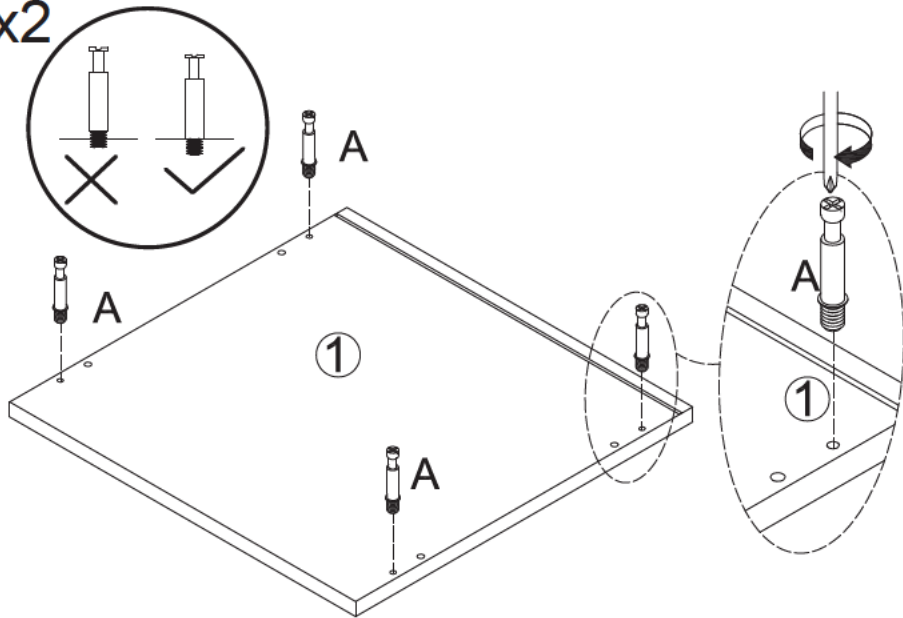

A x8



Ø6x35mm

8 x2

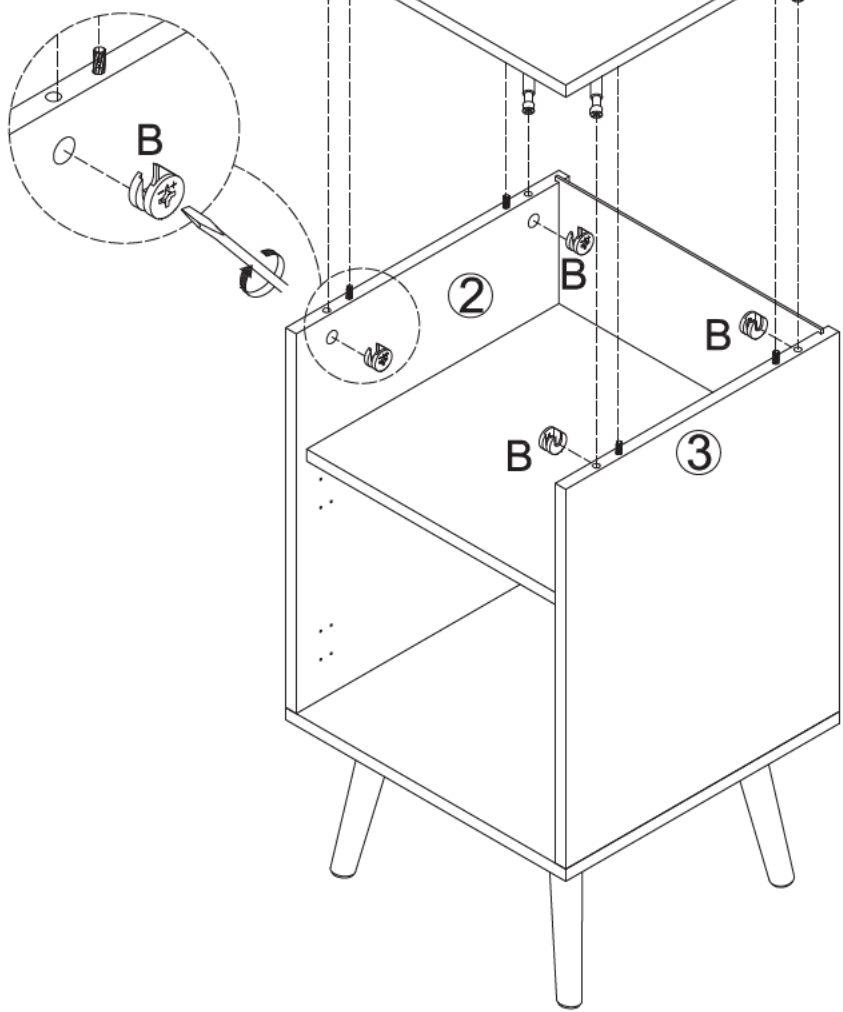
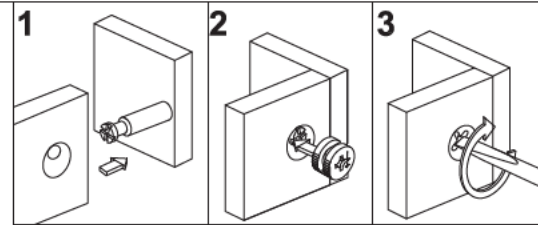

B x8



Ø15x10mm

9 x2

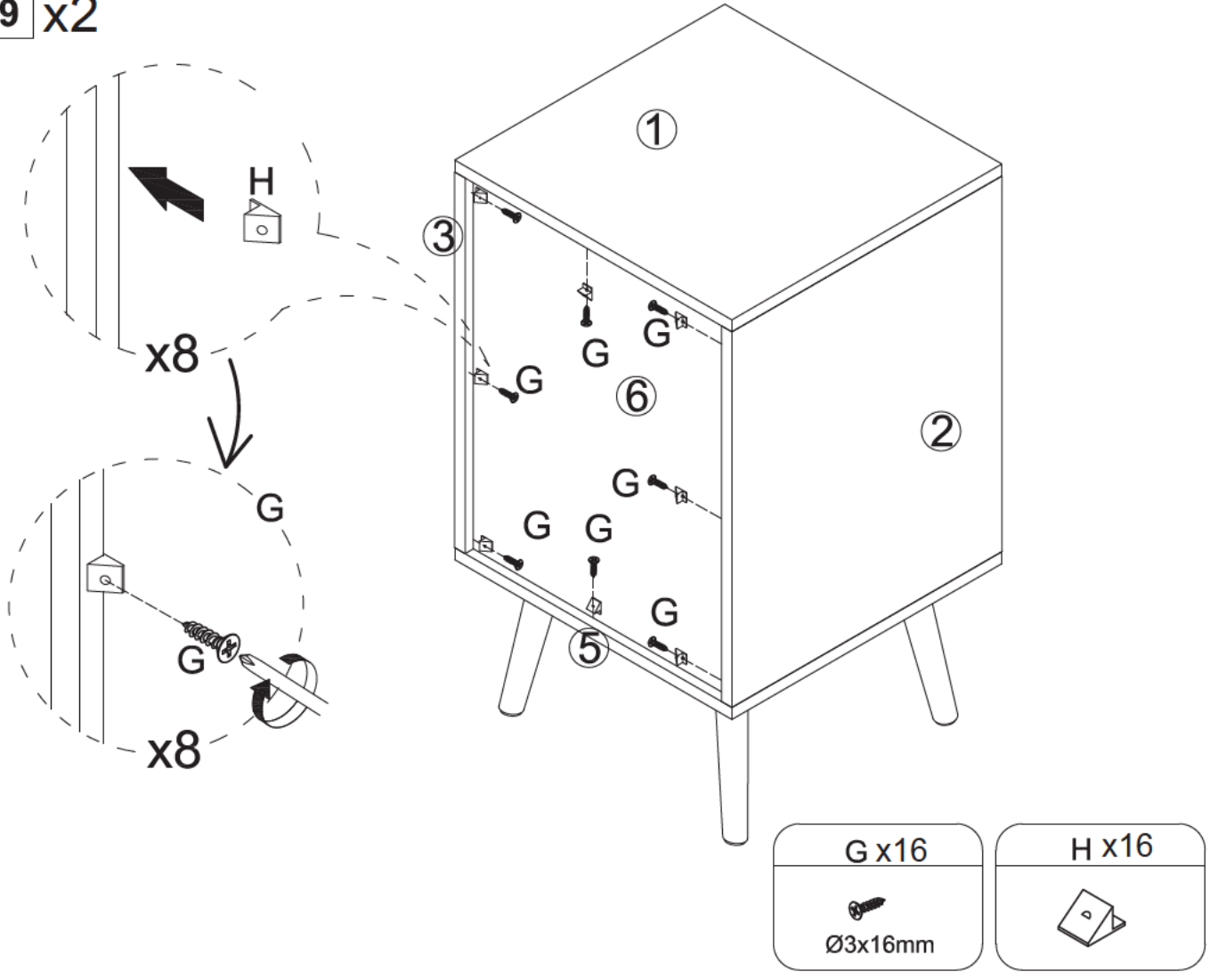



| |
|---|
| G x16 |
|  |
| Ø3x16mm |

| |
|---|
| H x16 |
|  |

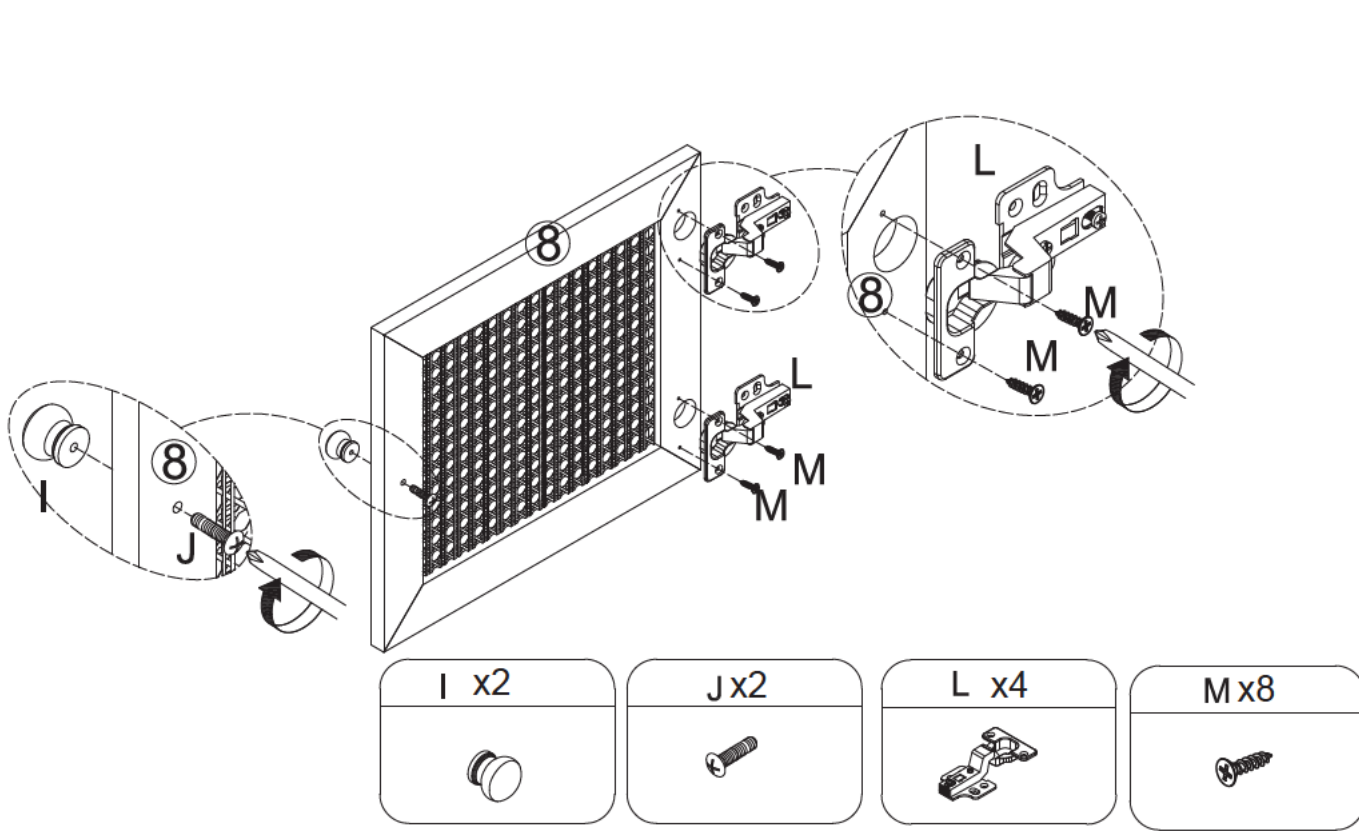
10 x2



| |
|---|
| I x2 |
|  |

| |
|---|
| J x2 |
|  |

| |
|---|
| L x4 |
|  |

| |
|---|
| M x8 |
|  |

11 x2

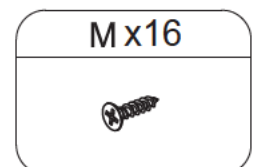
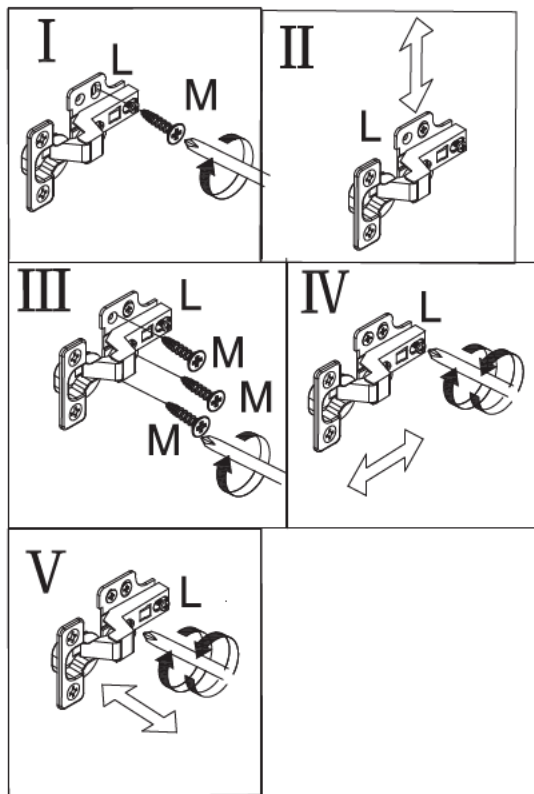
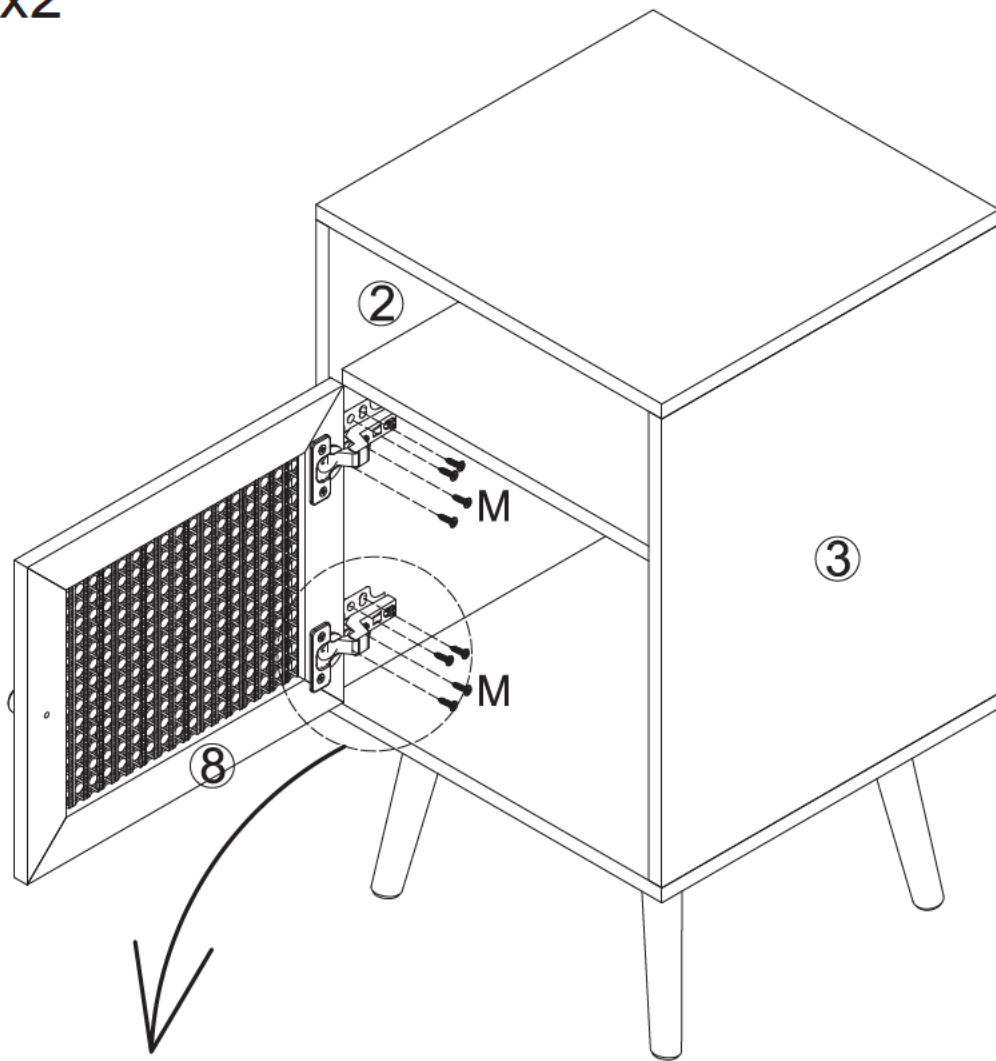

12 x2

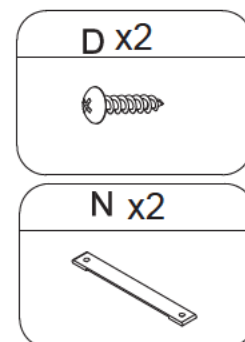
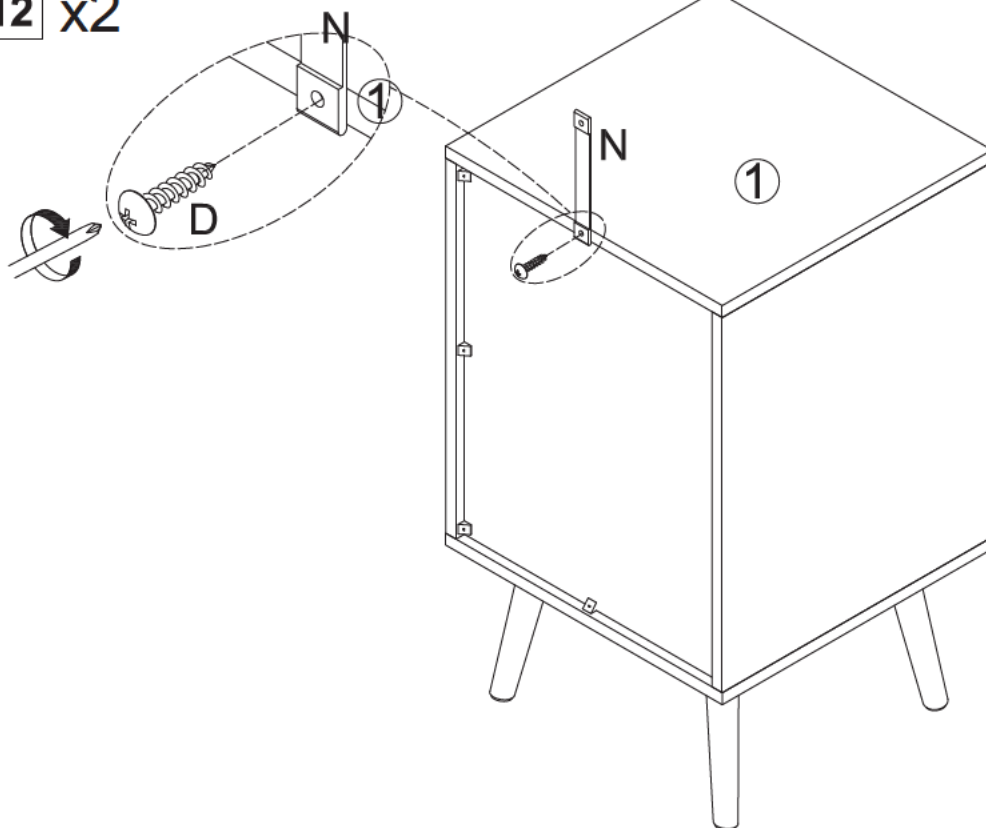

13 x2

