

Assembly Instruction

(BOX 1) HEADBOARD, FOOTBOARD, SIDE RAIL			(BOX 1) HARDWARE LIST		
NO	ITEM	QTY	NO	ITEM	QTY
A	HEADBOARD	1 PC	1	JCBB M8 x 30MM	8 PCS
B	FOOTBOARD	1 PC	2	JCBC M6 x 30MM	8 PCS
C	SIDE RAIL C1 C2	4 PCS	3	JCBC M6 x 60MM	8 PCS
D	LEGS CONE LEG NO.99 - 60x150(H)	4 PCS	4	M4 x 65MM	1 PC
E	CENTER RAIL 870mm	4 PCS	5	M5 x 70MM	1 PC
F	SIDE RAIL LEGS 240 x 80 x 30mm	2 PCS	6	FLAT HEAD CHIPBOARD SCREW M4 x 32MM	24 PCS
G	SUPPORT LEG 215mm	8 PCS	7	M6 FLAT WASHER	8 PCS
H	12 PCS SLAT 1947mm	2 PCS	8	SMALL ADJUSTER	8 PCS

Step 1 : Unzip the black non-woven fabric on the back of headboard and take out all the parts out

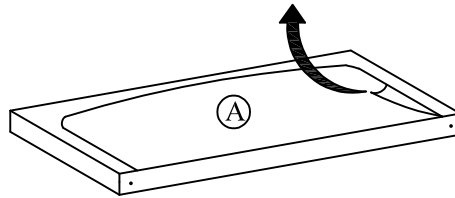

Attention: Zip the black non-woven fabric after take out the parts !!

BACK VIEW

Step 2 : Attach the headboard and footboard with legs as shown.

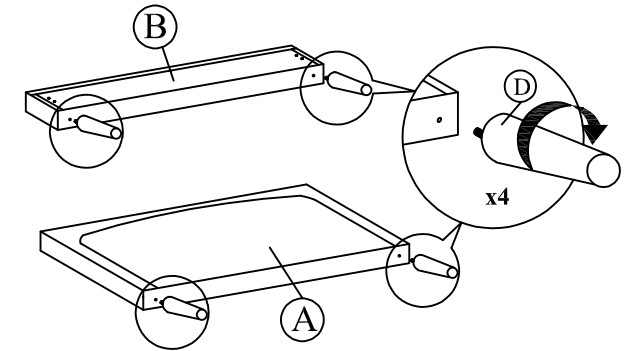

BACK VIEW

Step 3 : Attach the side rail leg (F) to the side rail (C).

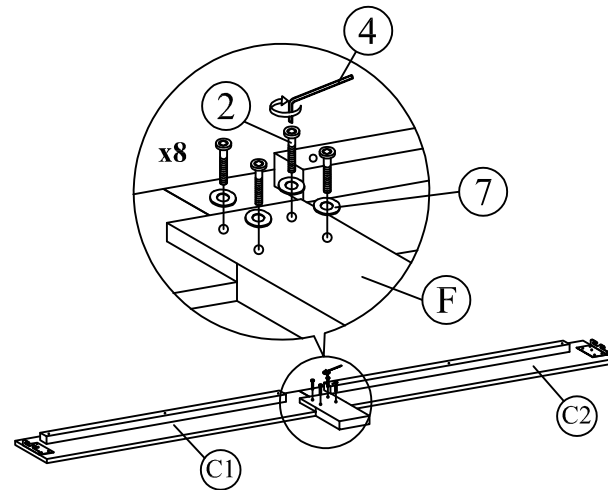

Step 4 : Attach side rail (C) to headboard (A) and footboard (B) by pushing the bracket down to fit it.

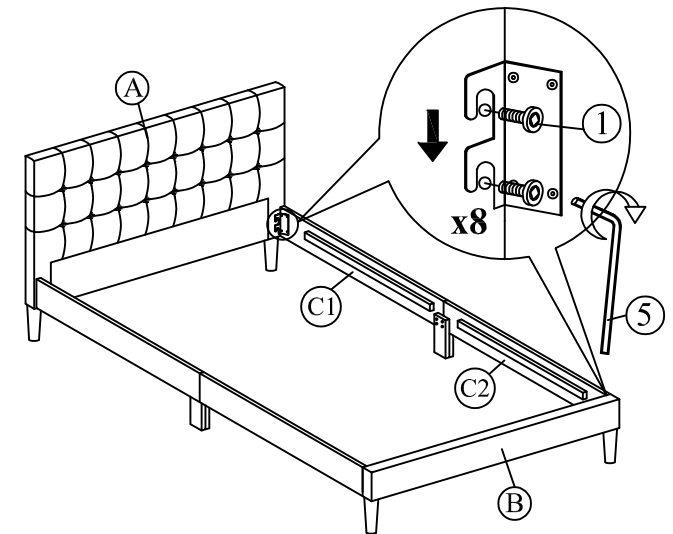

Step 4 : Attach the support legs (G) to the slats (H).

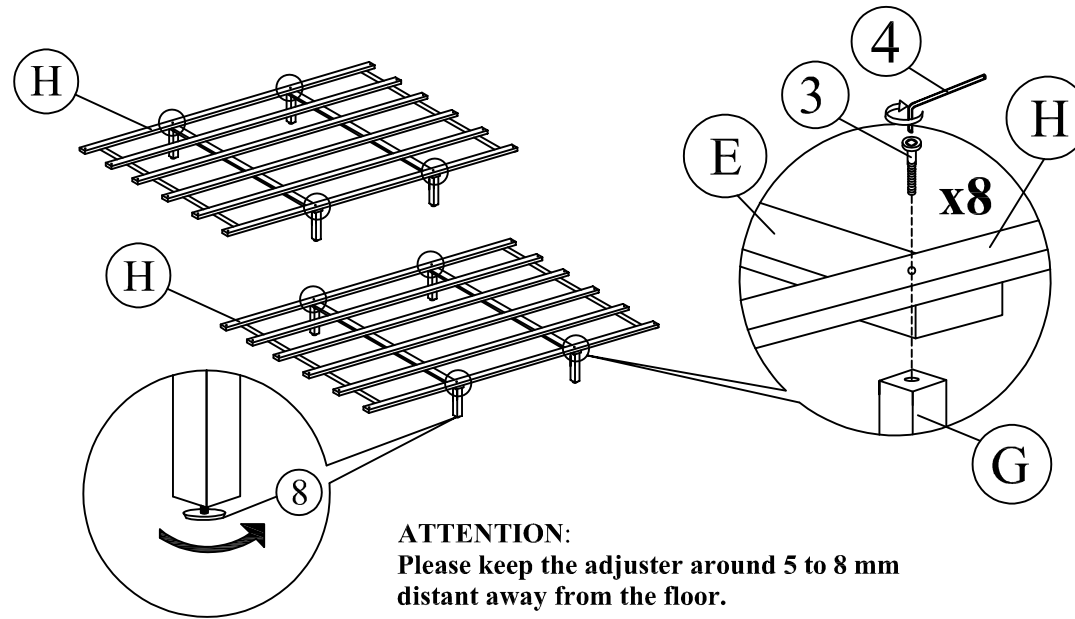

Step 5 : Tighten the 4 Corner with Allen Key (5). Install the bed slats to side rail. Tighten the slats with CSK screw. The distance of the slats should be sufficient to obtain desirable bed stability.

