





ASSEMBLY INSTRUCTION

944-706P Lindale Round Counter Height Table

HARDWARE LIST

A		Bolt	Ø5/16"*1-3/4"	8 PCS
B		Bolt	Ø5/16"*1-3/8"	4 PCS
C		Lock Washer	Ø5/16"	12 PCS
D		Flat Washer	Ø5/16"*19D	12 PCS
E		Allen Key	100*50*4mm	1 PCS

IMPORTANT NOTES

- . Place all wooden parts on clean and smooth surface such as rug or carpet to prevent the parts from being scratched.
- . Check to be sure that you have all parts and hardware.
- . Remove all wrapping materials, including staples and packing straps before you start to assemble.
- . Do not tighten all screws and bolts until completely assembled.
- . Keep all hardware out of the reach of children

Instruction For Option-01:

- STEP 1. Assemble base (1) and post (2) using bolt (A), lock washer (C), flat washer (D) and tighten them by allen key (E). See Figure 1
- STEP 2. Attach the bridge (3) to the leg assembly using bolt (A), lock washer (C), flat washer (D) and tighten them by allen key (E). See Figure 2
- STEP 3. Turn the table top (4) upside down on clean soft surface attach the post assembly to the top (1) as shown in the picture using bolt (B), lock washer (C), flat washer (D) and tighten them by allen key (E). See Figure 3
- STEP 4. Carefully turn the table up. Adjust the levelers at the bottom of the feet if needed to level table on uneven floor. See Figure 4

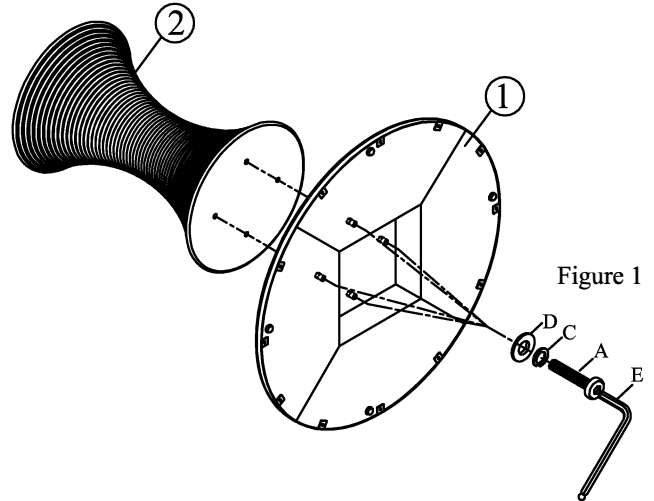

Figure 1

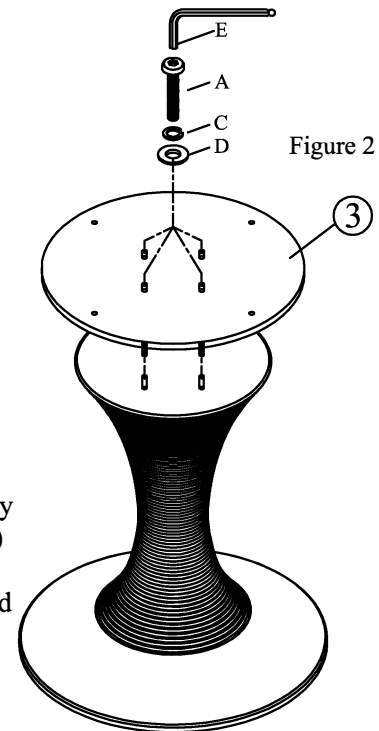

Figure 2

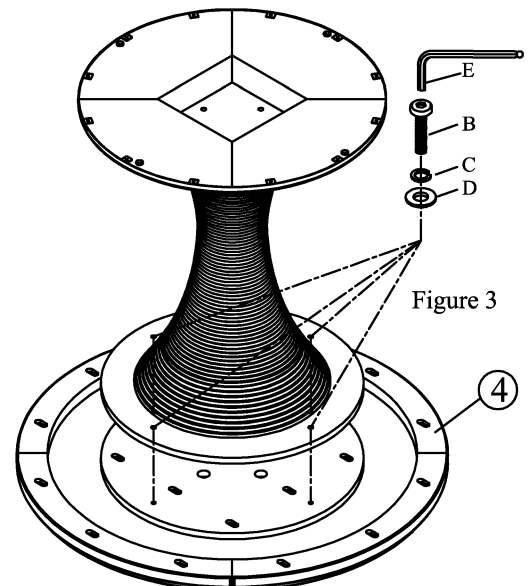

Figure 3

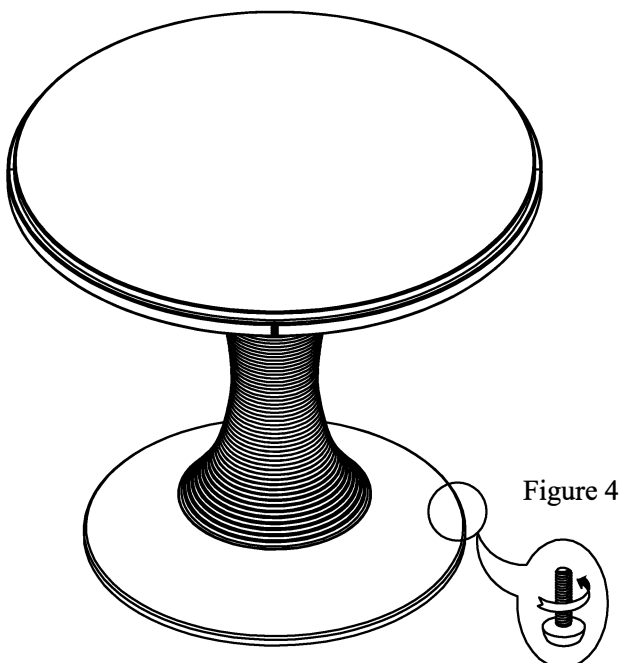

Figure 4

MADE IN VIETNAM