

Installation sanleitung Installation Instruction Instruction d'installation

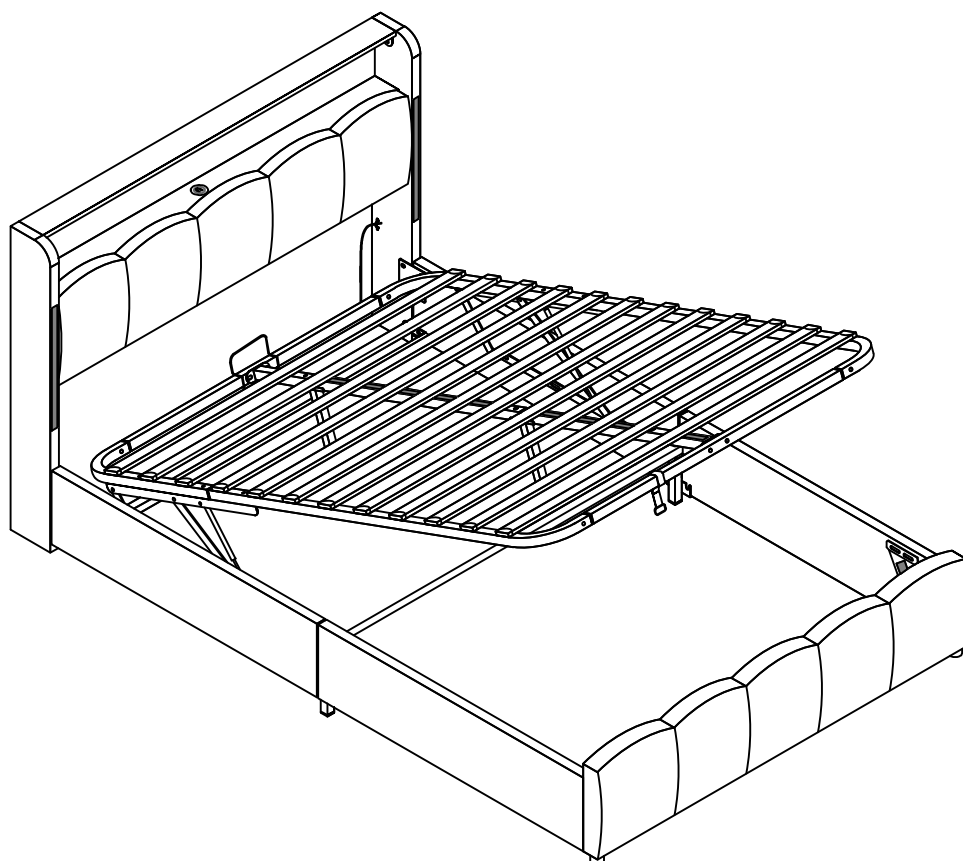

DE: Unser Produkt wird Ihnen in 2 Paketen geliefert. Die Lieferzeiten dieser 2 Pakete können abweichen, bitte haben Sie etwas Geduld und vielen Dank für Ihr Verständnis.

UK: Our product will be delivered to you in 2 packages. The delivery times of these 2 packages may differ, please be patient and thank you for your understanding.

FR: Notre produit vous sera livré en 2 colis. Les délais de livraison de ces 2 colis peuvent différer, soyez patient et merci pour votre compréhension.



English

IMPORTANT FOR GAS LIFT BEDS&MAINTAINANCE

- Please place the mattress on top of the bed frame.
- Please do not pull on the strap handles.
- Please press heavily to release the compressed gas.
- Periodically check all screw & fixings to ensure they are secure.
- When moving your product, carefully lift into place.
- Wipe clean with a slightly damp cloth- please do not use abrasive chemicals or bleach.
- Do NOT allow children to operate the lift mechanism.
- Do NOT allow children near the lift base when operating the mechanism.
- Do NOT stand inside the bed or the internal storage base.
- Do NOT overload the internal storage base.
- DO NOT jump on the product or any of its parts.

Deutsch

WICHTIG FÜR GASLIFT-BETTEN&WARTUNG

- Bitte legen Sie die Matratze oben auf den Bettrahmen.
- Bitte ziehen Sie nicht an den Gurtgriffen.
- Bitte drücken Sie kräftig, um das komprimierte Gas freizusetzen.
- Überprüfen Sie regelmäßig alle Schrauben und Befestigungen, um sicherzustellen, dass sie sicher sind.
- Wenn Sie Ihr Produkt bewegen, heben Sie es vorsichtig an seinen Platz.
- Mit einem leicht feuchten Tuch abwischen - bitte keine scheuernden Chemikalien oder Bleichmittel verwenden.
- Erlauben Sie Kindern NICHT, den Hebemechanismus zu bedienen.
- Lassen Sie Kinder NICHT in die Nähe des Liftsockels, wenn Sie den Mechanismus bedienen.
- Stellen Sie sich NICHT in das Bett oder in die Innenablage.
- Überlasten Sie den internen Liftsockel NICHT.
- Springen Sie NICHT auf das Produkt oder eines seiner Teile.

Français

IMPORTANT POUR LES LITS À RELEVAGE DE GAZ&MAINTENANCE

- Veuillez placer le matelas sur le dessus du cadre de lit.
- Ne tirez pas sur les poignées de la sangle.
- Appuyez fortement pour libérer le gaz comprimé.
- Vérifiez régulièrement que toutes les vis et fixations sont bien en place.
- Lorsque vous déplacez votre produit, soulevez-le avec précaution pour le mettre en place.
- Nettoyez avec un chiffon légèrement humide - n'utilisez pas de produits chimiques abrasifs ou d'eau de Javel.
- Ne laissez pas les enfants utiliser le mécanisme de levage.
- Ne laissez pas les enfants s'approcher de la base de levage lorsqu'ils actionnent le mécanisme.
- Ne vous tenez PAS à l'intérieur du lit ou de la base de stockage interne.
- Ne surchargez pas la base de stockage interne.
- Ne pas sauter sur le produit ou l'une de ses parties.

Italiano

IMPORTANTE PER I LETTI CON SOLLEVAMENTO A GAS E LA MANUTENZIONE

- Posizionare il materasso sopra la struttura del letto.
- Non tirare le maniglie della cinghia.
- Premere con forza per rilasciare il gas compresso.
- Controllare periodicamente tutte le viti e i fissaggi per assicurarsi che siano saldi.
- Quando si sposta il prodotto, sollevarlo con cautela.
- Pulire con un panno leggermente umido, senza usare prodotti chimici abrasivi o candeggina.
- NON permettere ai bambini di azionare il meccanismo di sollevamento.
- NON permettere ai bambini di avvicinarsi alla base di sollevamento quando si aziona il meccanismo.
- NON sostare all'interno del letto o della base di contenimento interna.
- NON sovraccaricare la base di contenimento interna.
- NON saltare sul prodotto o sulle sue parti.

Español

IMPORTANTE PARA LAS CAMAS ELEVADORAS DE GAS&MANTENIMIENTO



- Coloque el colchón sobre el somier.
- No tire de las asas de la correa.
- Presione con fuerza para liberar el gas comprimido.
- Compruebe periódicamente que todos los tornillos y fijaciones estén bien sujetos.
- Al mover el producto, levántelo con cuidado para colocarlo en su sitio.
- Limpie con un paño ligeramente humedecido; no utilice productos químicos abrasivos ni lejía.
- NO permita que los niños accionen el mecanismo de elevación.
- NO permita que los niños se acerquen a la base elevadora cuando accionen el mecanismo.
- NO se ponga de pie dentro de la cama o de la base de almacenamiento interna.
- NO sobrecargue el somier.
- NO salte sobre el producto ni sobre ninguna de sus piezas.



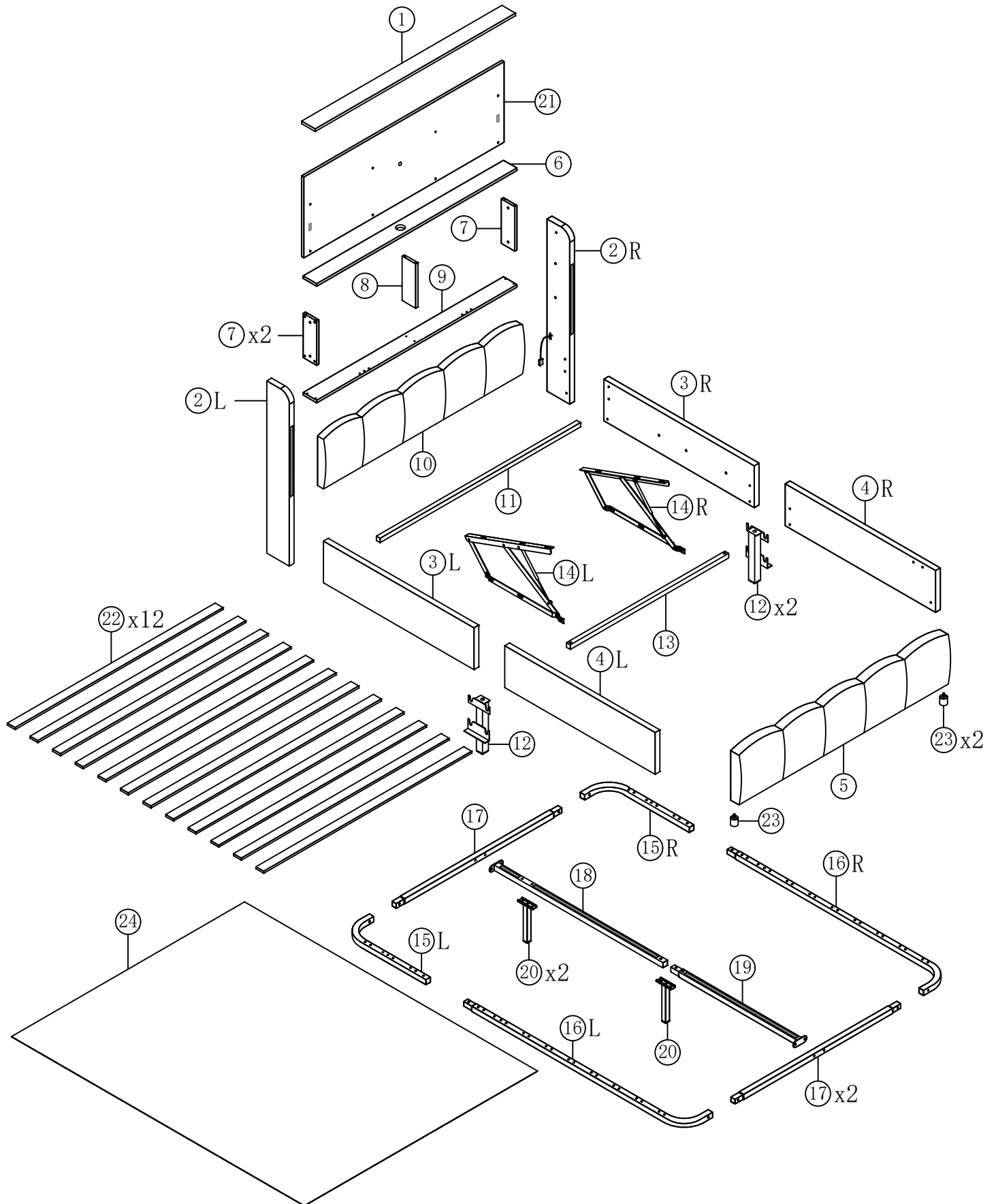



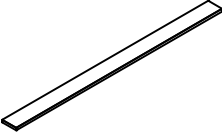
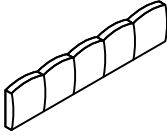
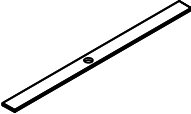

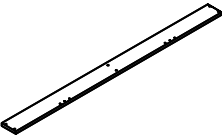
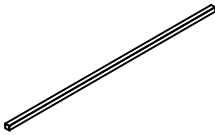
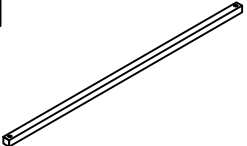
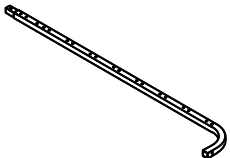
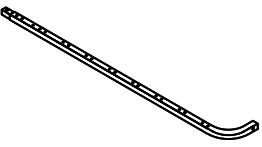
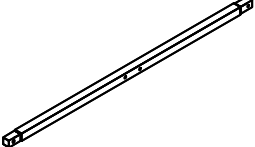
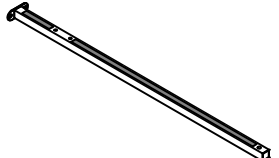
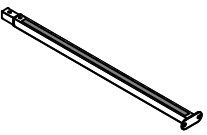
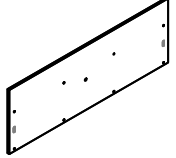
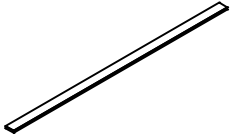
Stückliste





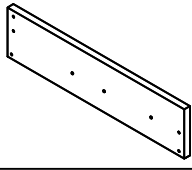
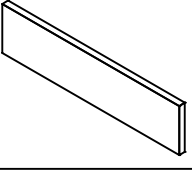
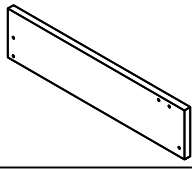
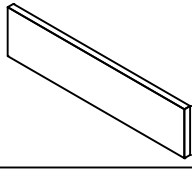
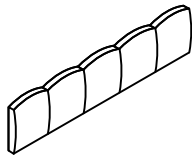
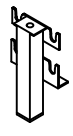
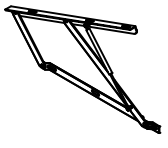
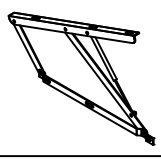

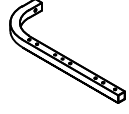
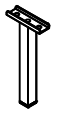

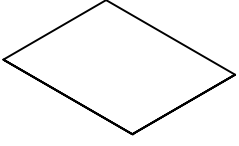













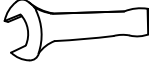

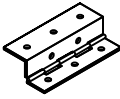
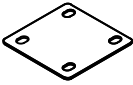
Liste der Einzelteile

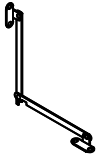
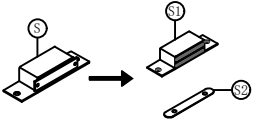
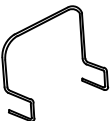

1		5		6		7	
Oberes Regal-1Stück		Fußbrett-1Stück		Unterregal-1Stück		Seitenregal-2Stück	
8		9		11		13	
Zwischenregal-1Stück		Bodenplatte-1Stück		Kopfteil Querstange-1Stück		Querstange-1Stück	
16R		16L		17		18	
Seitenleiste mit Metallrahmen-1Stück		Seitenleiste mit Metallrahmen-1Stück		Metallrahmen Querstange-2Stück		Zentrale Stützstange-1Stück	
19		21		22			
Zentrale Stützstange-1Stück		Rückwand des Staufachs-1Stück		Lamellen-12Stück			

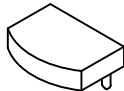
Liste der Einzelteile

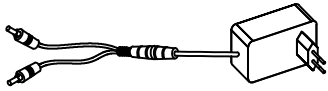
2R		2L		3R		3L	
Beine des Kopfteils-1Stück		Beine des Kopfteils-1Stück		Seitengitte-1Stück		Seitengitte-1Stück	
4R		4L		10		12	
Seitengitte-1Stück		Seitengitte-1Stück		Kopfteil-1Stück		Seitenschienen Stützbeine-2Stück	
14R		14L		15R		15L	
Gasfeder-1Stück		Gasfeder-1Stück		Seitenleiste mit Metallrahmen-1Stück		Seitenleiste mit Metallrahmen-1Stück	
20		23		24			
Zwischenstützbein-2Stück		Bettfüße-2Stück		Vliesstoff-1Stück			

Hardwareliste

<p>A</p> 	<p>B1</p>  <p>M8x12mm</p>	<p>B2</p>  <p>M8x16mm</p>	<p>C</p>  <p>M8x45mm</p>
<p>Inbusschlüssel(1Stück)</p>	<p>Bolzen(6Stück)</p>	<p>Bolzen(50Stück)</p>	<p>Bolzen(24Stück)</p>
<p>D</p>  <p>M6x25mm</p>	<p>E</p>  <p>M3x16mm</p>	<p>F</p>  <p>M4x16mm</p>	<p>G</p> 
<p>Bolzen(8Stück)</p>	<p>Bolzen(19Stück)</p>	<p>Nägel(16Stück)</p>	<p>Scheibe(8Stück)</p>
<p>H</p> 	<p>I</p> 	<p>J</p> 	<p>K</p> 
<p>Nuss(4Stück)</p>	<p>Nuss(14Stück)</p>	<p>Schraubenschlüssel(1Stück)</p>	<p>Schubladenbeschläge(12Stück)</p>
<p>L</p> 	<p>M</p> 	<p>N</p> 	<p>O</p> 
<p>Schubladenbeschläge(12Stück)</p>	<p>Scharnier(2Stück)</p>	<p>Eisen mit vier Löchern(4Stück)</p>	<p>Eisen mit drei Löchern "7"(2Stück)</p>
<p>P</p> 	<p>Q</p> 	<p>R</p> 	<p>S</p> 
<p>Kleines "7"-Gelenk(6Stück)</p>	<p>Anschlußscheibe(2Stück)</p>	<p>Scharnier(2Stück)</p>	<p>Rollenriegel(2Stück)</p>
<p>T</p> 	<p>U</p> 	<p>V</p> 	<p>W</p> 
<p>Stopfen(1Stück)</p>	<p>Zugband(1Stück)</p>	<p>Abdeckung für Endlatten(24Stück)</p>	<p>Farbregler(1Stück)</p>
<p>X</p> 	<p>Y</p> 		
<p>Netzadapter(1Stück)</p>	<p>USB(1Stück)</p>		



<div data-bbox="81 136 135 190" style="border: 1px solid black; padding: 2px;">B1</div> <div data-bbox="287 201 367 246" style="text-align: center;">  </div> <div data-bbox="279 257 375 291" style="text-align: center;">M8x12mm</div>	<div data-bbox="558 136 614 190" style="border: 1px solid black; padding: 2px;">B2</div> <div data-bbox="758 201 837 246" style="text-align: center;">  </div> <div data-bbox="750 257 845 291" style="text-align: center;">M8x16mm</div>	<div data-bbox="1029 136 1085 190" style="border: 1px solid black; padding: 2px;">C</div> <div data-bbox="1220 201 1324 246" style="text-align: center;">  </div> <div data-bbox="1220 257 1324 291" style="text-align: center;">M8x45mm</div>
Bolzen(6Stück)	Bolzen(50Stück)	Bolzen(24Stück)

DE:Bitte beachten Sie, dass die Formen der Schrauben B1,B2 und C ähnlich sind.

Bitte installieren Sie entsprechend der Anleitung und unterscheiden Sie sie!

UK>Please note that the shapes of screws B1,B2 and C are similar. Please install according to the instructions and distinguish them!

FR:Notez que les vis B1,B2 et C et ont des formes similaires. Veuillez les installer en suivant les instructions pour les séparer!

<div data-bbox="81 1178 135 1232" style="border: 1px solid black; padding: 2px;">E</div> <div data-bbox="287 1243 367 1288" style="text-align: center;">  </div> <div data-bbox="279 1299 375 1332" style="text-align: center;">M3x16mm</div>	<div data-bbox="558 1178 614 1232" style="border: 1px solid black; padding: 2px;">F</div> <div data-bbox="758 1243 837 1288" style="text-align: center;">  </div> <div data-bbox="750 1299 845 1332" style="text-align: center;">M4x16mm</div>
Nägel(19Stück)	Nägel(16Stück)

DE:Bitte beachten Sie, dass die Formen der Schrauben E und F ähnlich sind. Bitte installieren Sie entsprechend der Anleitung und unterscheiden Sie sie!

UK>Please note that the shapes of screws E and F are similar. Please install according to the instructions and distinguish them!

FR:Notez que les vis E et F et ont des formes similaires. Veuillez les installer en suivant les instructions pour les séparer!

DE: Vor dem Einbau die Schrauben in die Löcher stecken und festziehen, aber nicht bis 100%, 70% bis 80% anziehen reicht aus. Schließlich, nachdem alle Schrauben installiert sind, ziehen Sie alle Schrauben auf 100%.

Wenn Sie auf diese Probleme stoßen, wie z. B. Fehlausrichtung der Löcher oder Unfähigkeit, bestimmte Teile zu installieren, überprüfen Sie bitte, ob die Schrauben korrekt verwendet werden und passen Sie die Dichtigkeit der Schrauben an.

UK: Before installation, insert the screws into the holes and tighten them, but do not tighten them to 100%, 70% to 80% is sufficient. Finally, after all screws are installed, tighten all screws to 100%.



If you encounter these issues, such as if the holes cannot be aligned or some parts cannot be installed, please check if the screws are used correctly and adjust the tightness of the screws.

FR: Insérer la vis dans le trou avant la fin de l'assemblage, serrer la vis, mais ne pas serrer à 100%, 70% ~ 80% est correct. Enfin, une fois que toutes les vis sont bien serrées, toutes les vis sont serrées à 100%.

Si vous rencontrez ces problèmes, par exemple si les trous ne sont pas alignés ou si certaines pièces ne peuvent pas être montées, vérifiez que les vis sont utilisées correctement et Ajustez leur serrage.



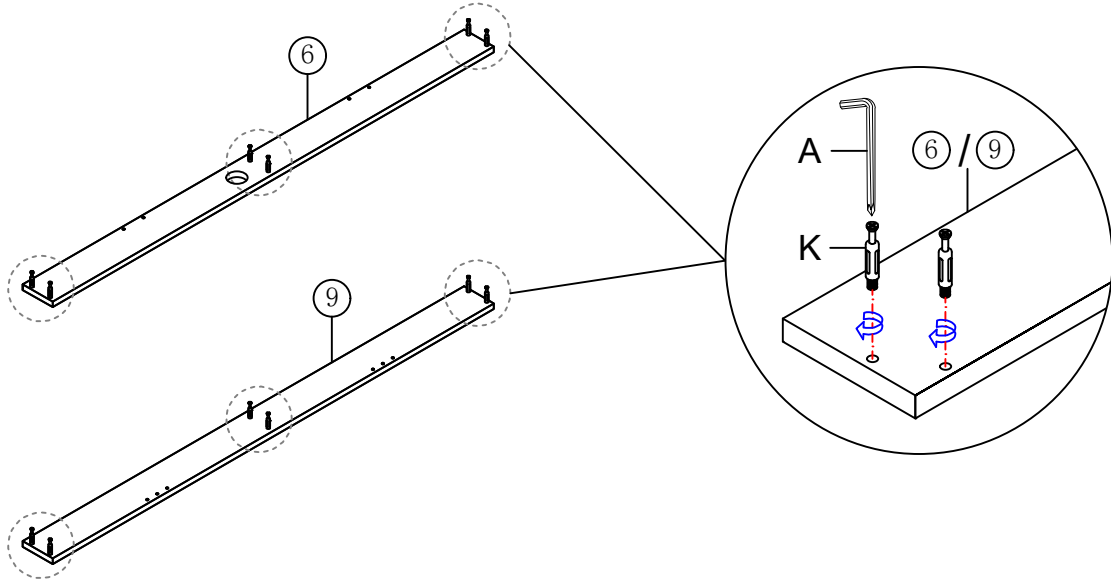

Hinweis: Wir empfehlen Ihnen, Ihr Bett im ebenen Boden aufzubauen.

Schritt 1:

A		K	
		12Stück	





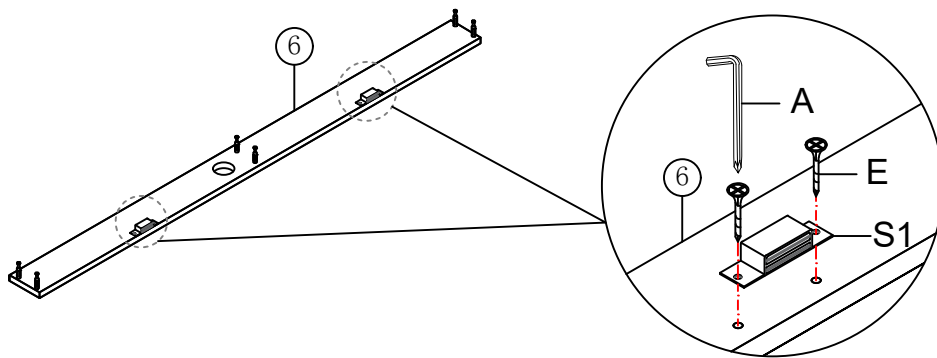

Schritt 2:

A		E	 M3x16mm	F	 M4x16mm	S1	
		4Stück				2Stück	





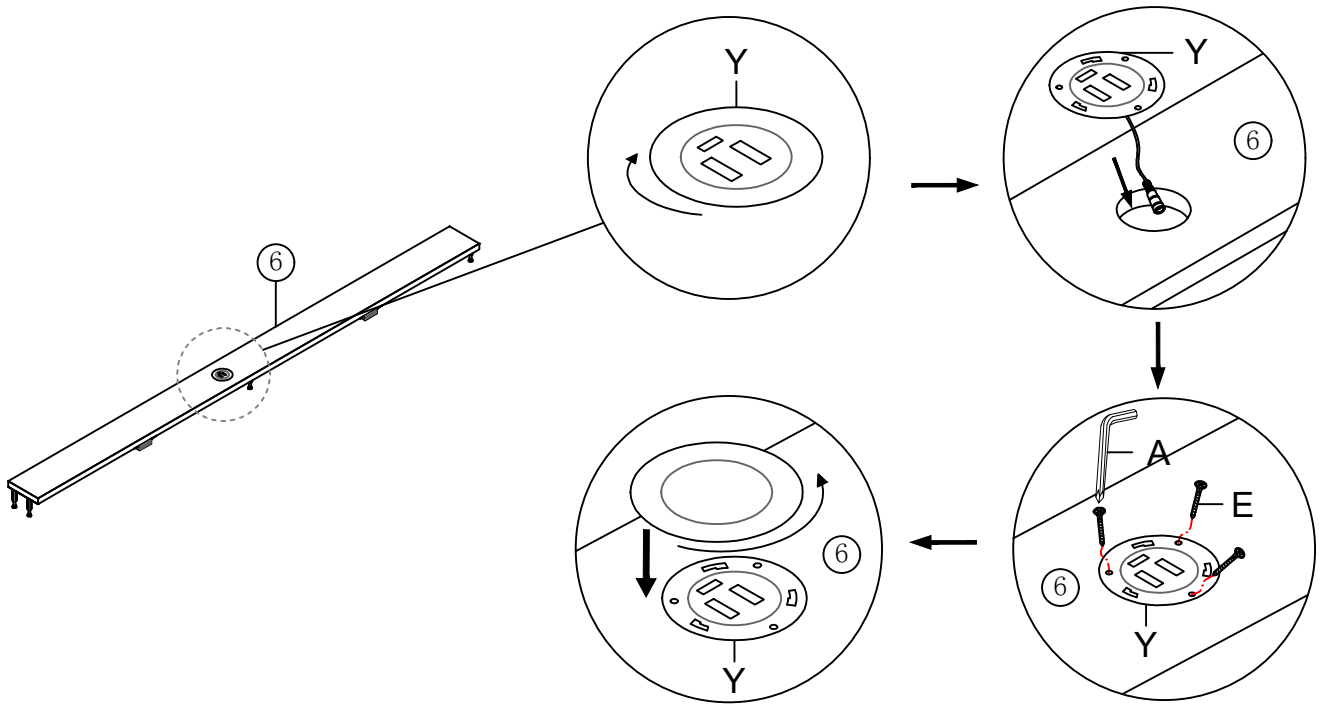

Schritt 3:

<p>A</p> 	<p>E</p>  <p>M3x16mm</p> <p>3Stück</p>	<p>F</p>  <p>M4x16mm</p>	<p>Y</p>  <p>1Stück</p>
--	---	---	--



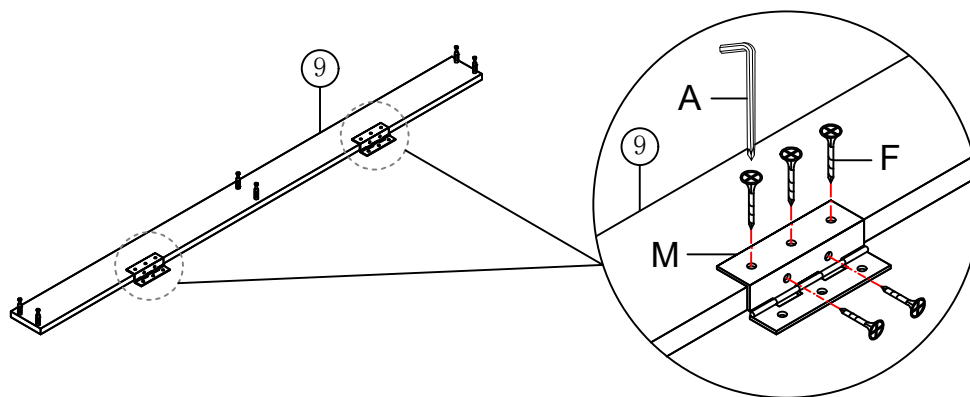

Schritt 4:

<p>A</p> 	<p>E</p>  <p>M3x16mm</p>	<p>F</p>  <p>M4x16mm</p> <p>10Stück</p>	<p>M</p>  <p>2Stück</p>
--	---	--	--



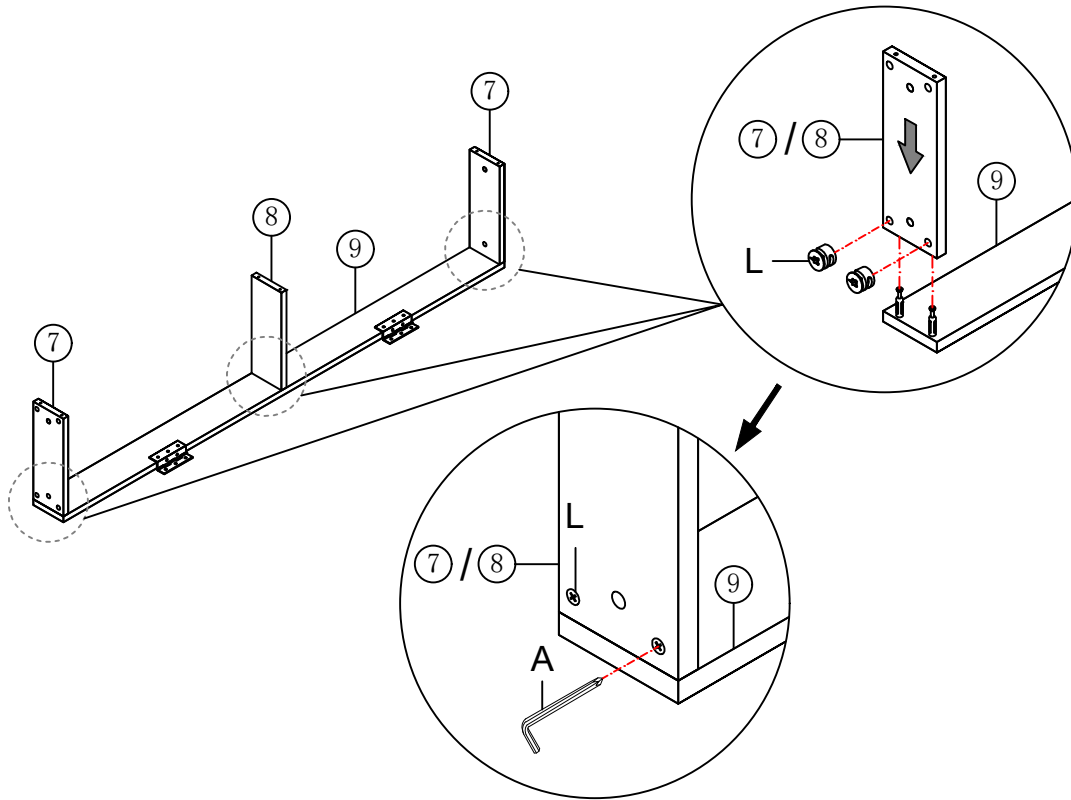

Schritt 5:

A	L
	
6Stück	





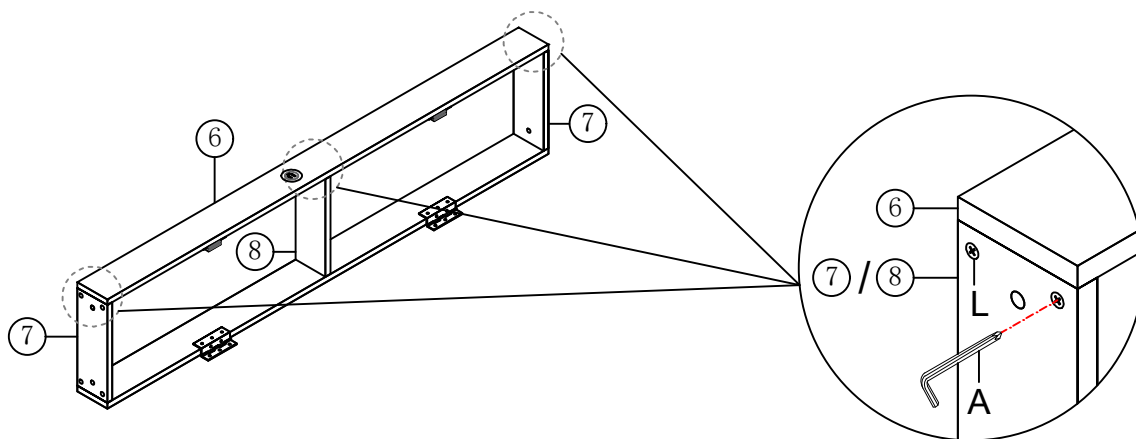

Schritt 6:

A	L
	
6Stück	







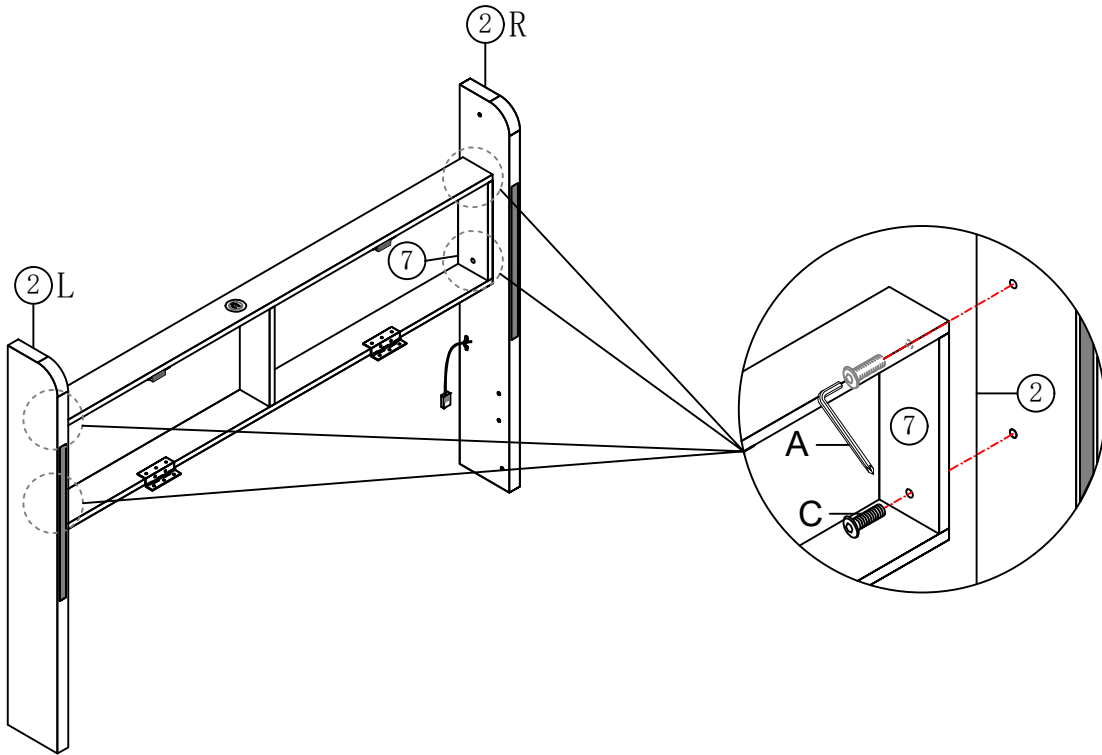

Schritt 7:

A		B1  M8x12mm	B2  M8x16mm	C  M8x45mm
				4Stück



Schritt 8:



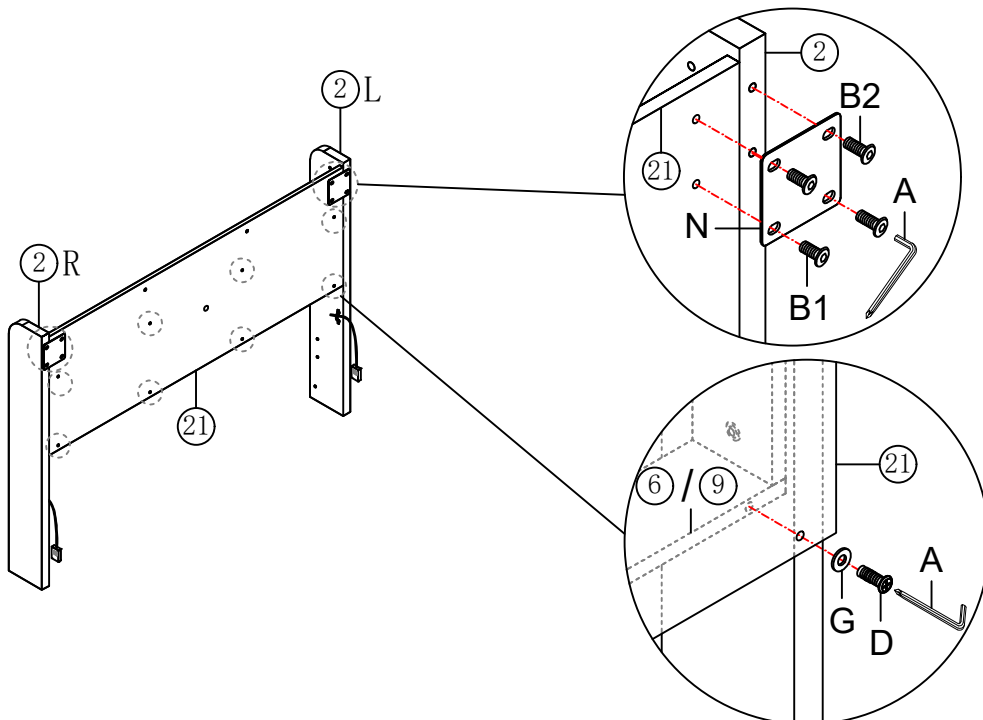

A		B1  M8x12mm	B2  M8x16mm	C  M8x45mm
		4Stück	4Stück	
D	 M6x25mm	G 	N 	
	8Stück	8Stück	2Stück	

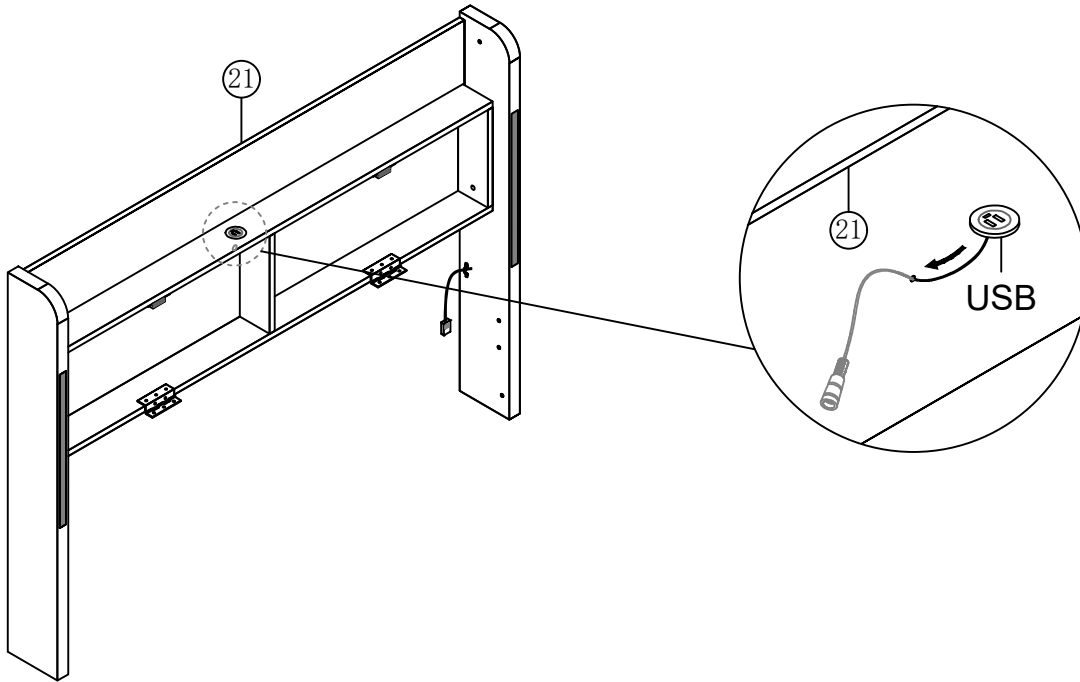

Schritt 9:





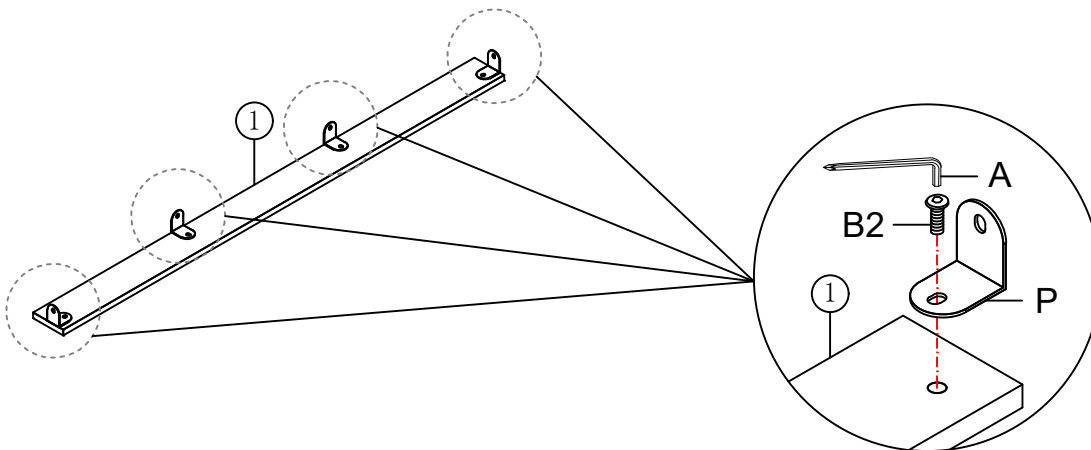

Schritt 10:

<p>A</p> 	<p>B1</p>  <p>M8x12mm</p>	<p>B2</p>  <p>M8x16mm</p> <p>4Stück</p>	<p>C</p>  <p>M8x45mm</p>	<p>P</p>  <p>4Stück</p>
--	---	--	--	--





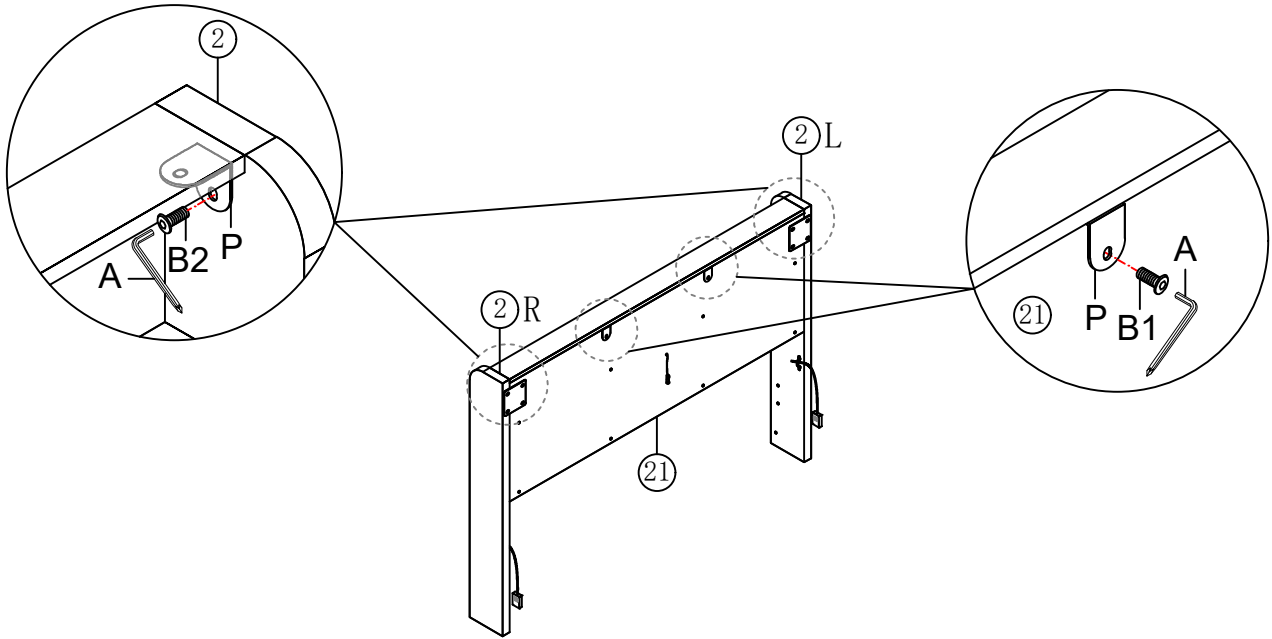

Schritt 11:

<p>A</p> 	<p>B1</p>  <p>M8x12mm</p> <p>2Stück</p>	<p>B2</p>  <p>M8x16mm</p> <p>2Stück</p>	<p>C</p>  <p>M8x45mm</p>
--	--	--	---



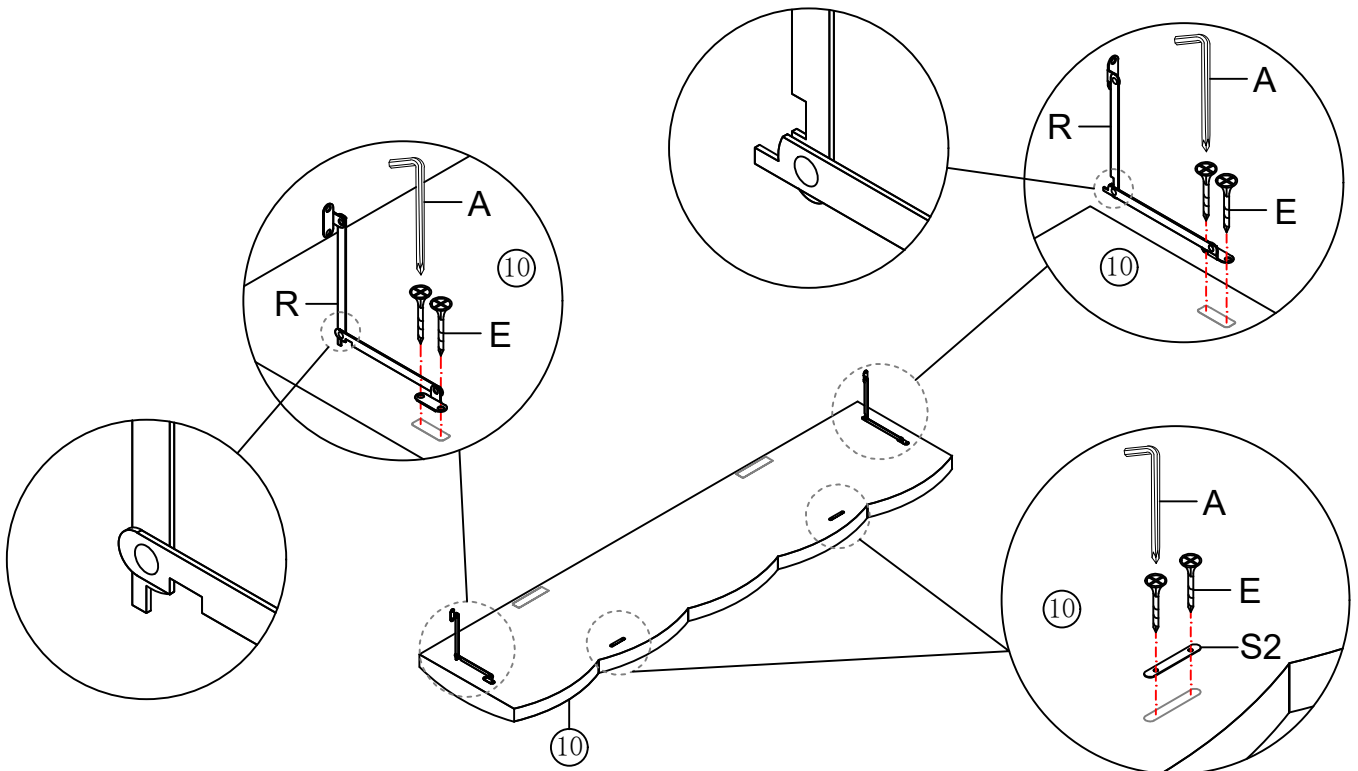

Schritt 12:

<p>A</p> 	<p>E</p>  <p>M3x16mm</p> <p>8Stück</p>	<p>F</p>  <p>M4x16mm</p>	<p>R</p>  <p>2Stück</p>	<p>S2</p>  <p>2Stück</p>
--	---	---	--	---



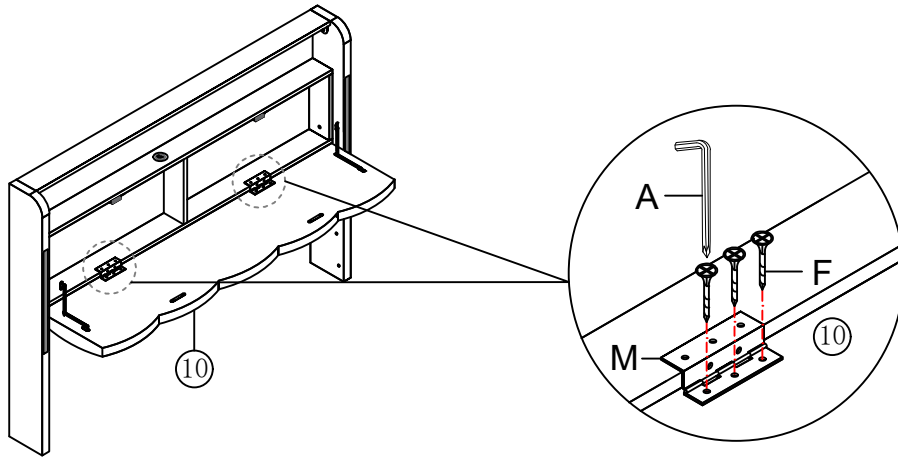

Schritt 13:

A		E	 M3x16mm	F	 M4x16mm
				6Stück	



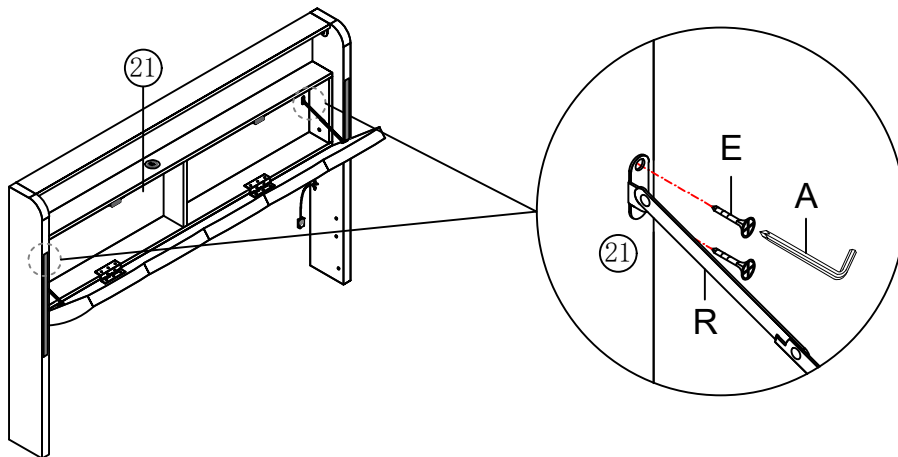

Schritt 14:

A		E	 M3x16mm		
				4Stück	





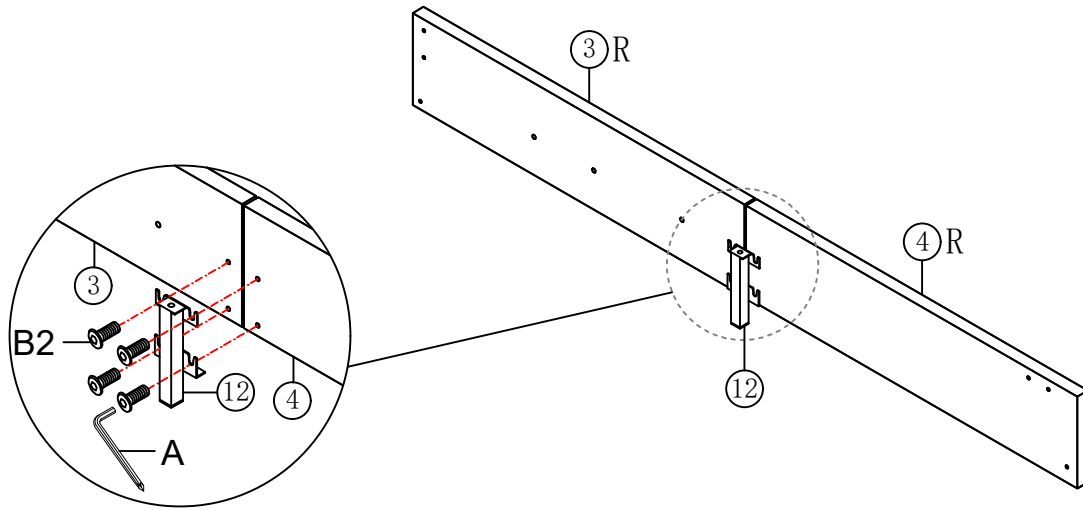

Schritt 15x2:

A 	B2  M8x16mm 8Stück	C  M8x45mm
--	---	---



Schritt 16:



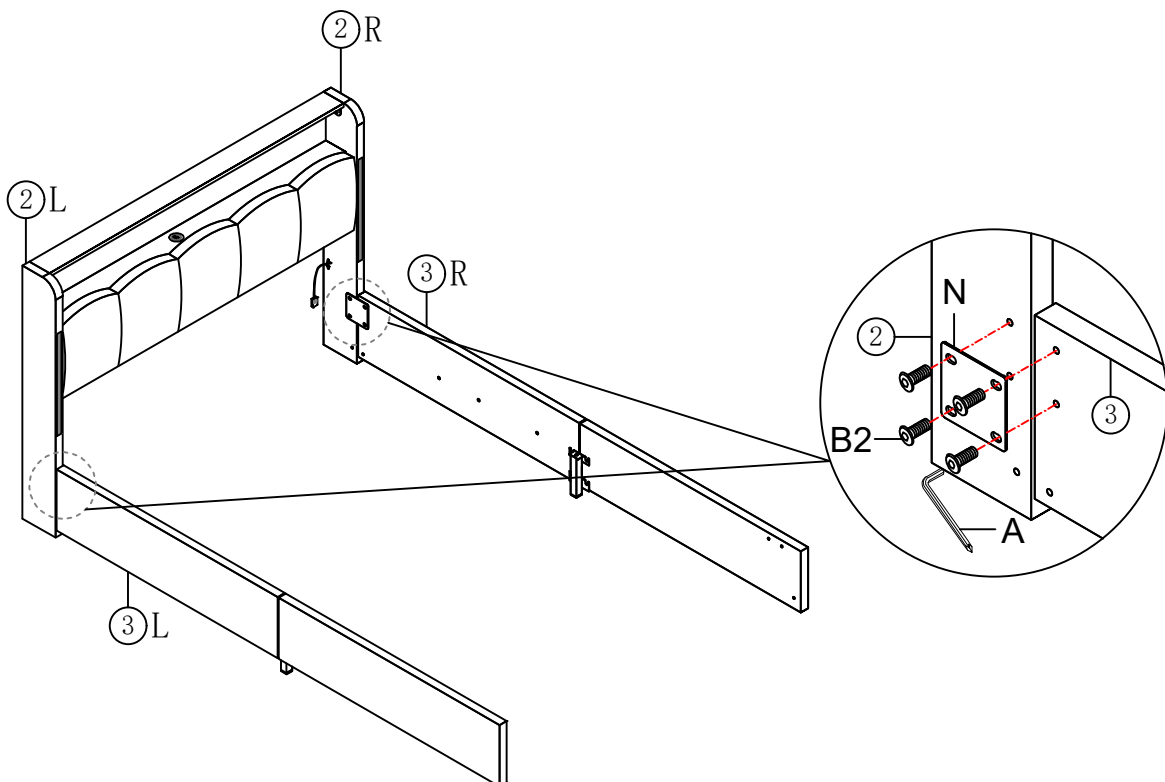

A 	B2  M8x16mm 8Stück	C  M8x45mm	N  2Stück
---	---	---	---

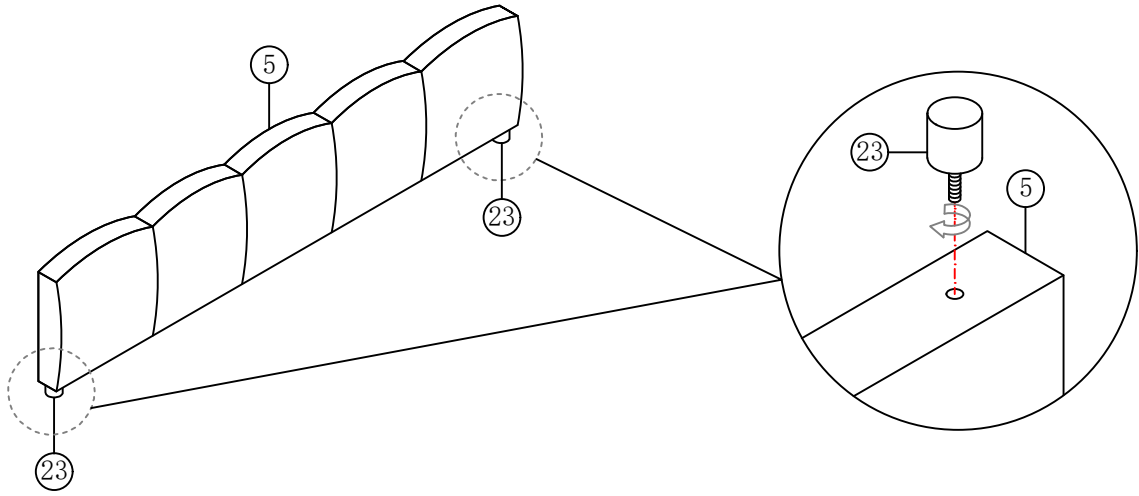

Schritt 17:





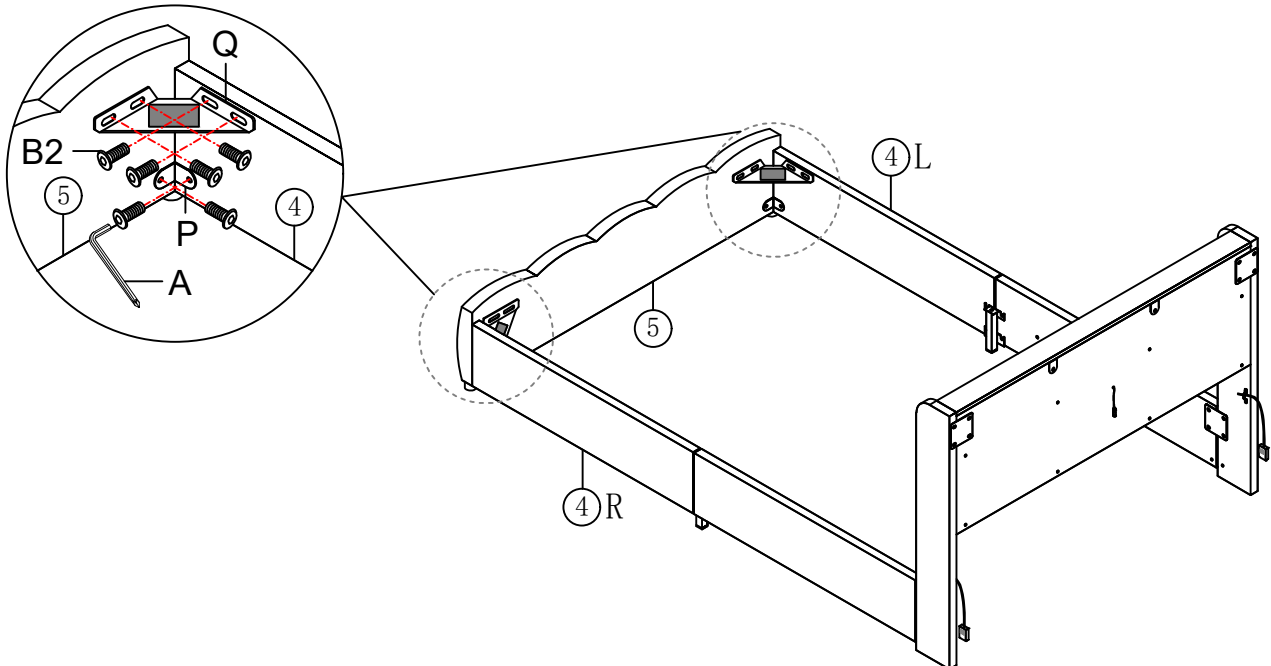

Schritt 18:

A  12Stück	B2  M8x16mm 12Stück	 C  M8x45mm 	P  2Stück	Q  2Stück
--	--	---	---	---



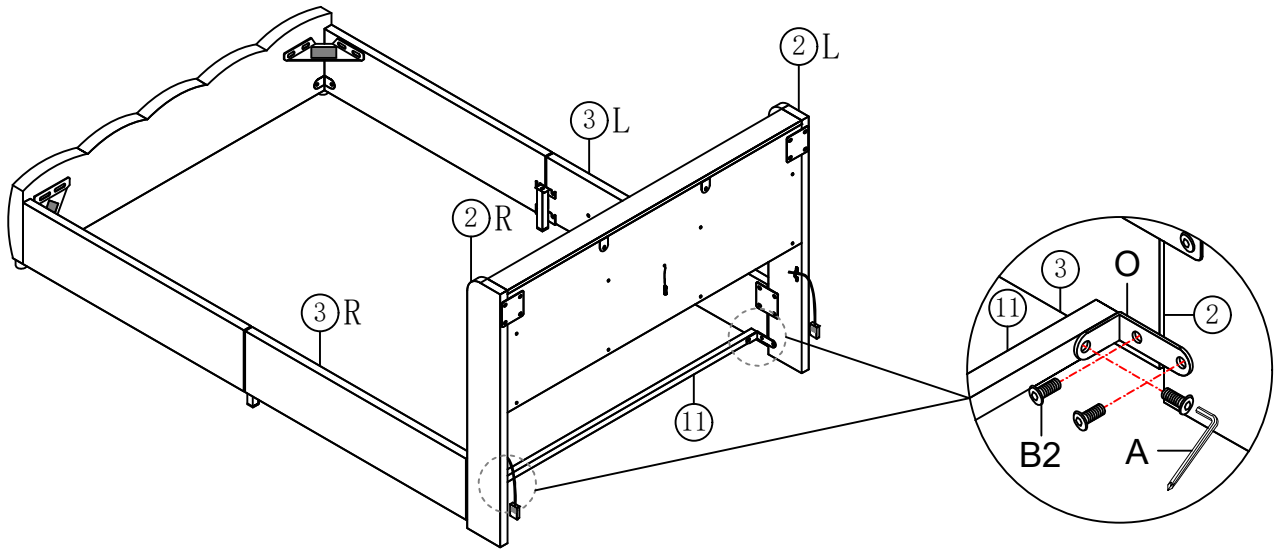

Schritt 19:

<p>A</p> 	<p>B2</p>  <p>M8x16mm</p> <p>6Stück</p>	<p>C</p>  <p>M8x45mm</p>	<p>O</p>  <p>2Stück</p>
--	--	---	--



Schritt 20:



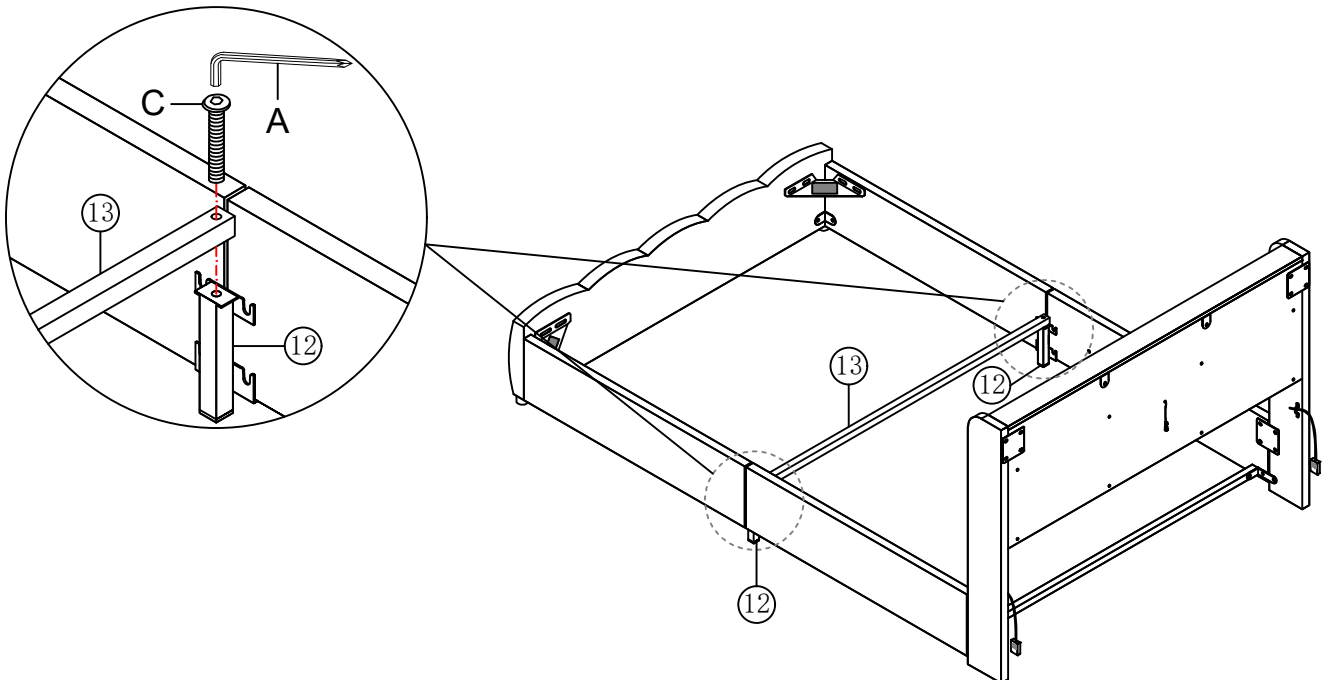

<p>A</p> 	<p>B2</p>  <p>M8x16mm</p>	<p>C</p>  <p>M8x45mm</p> <p>2Stück</p>
---	--	---

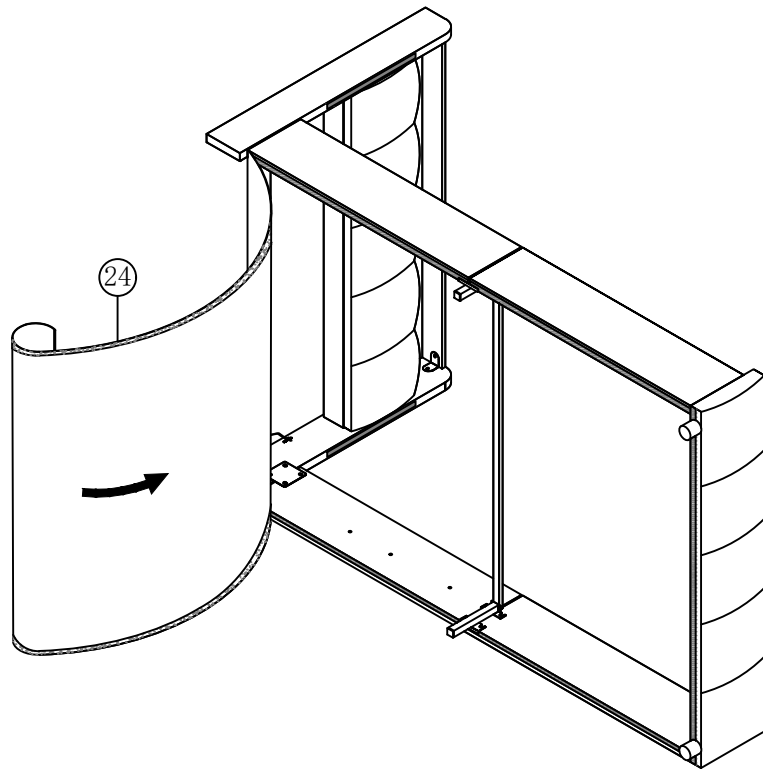

Schritt 21:





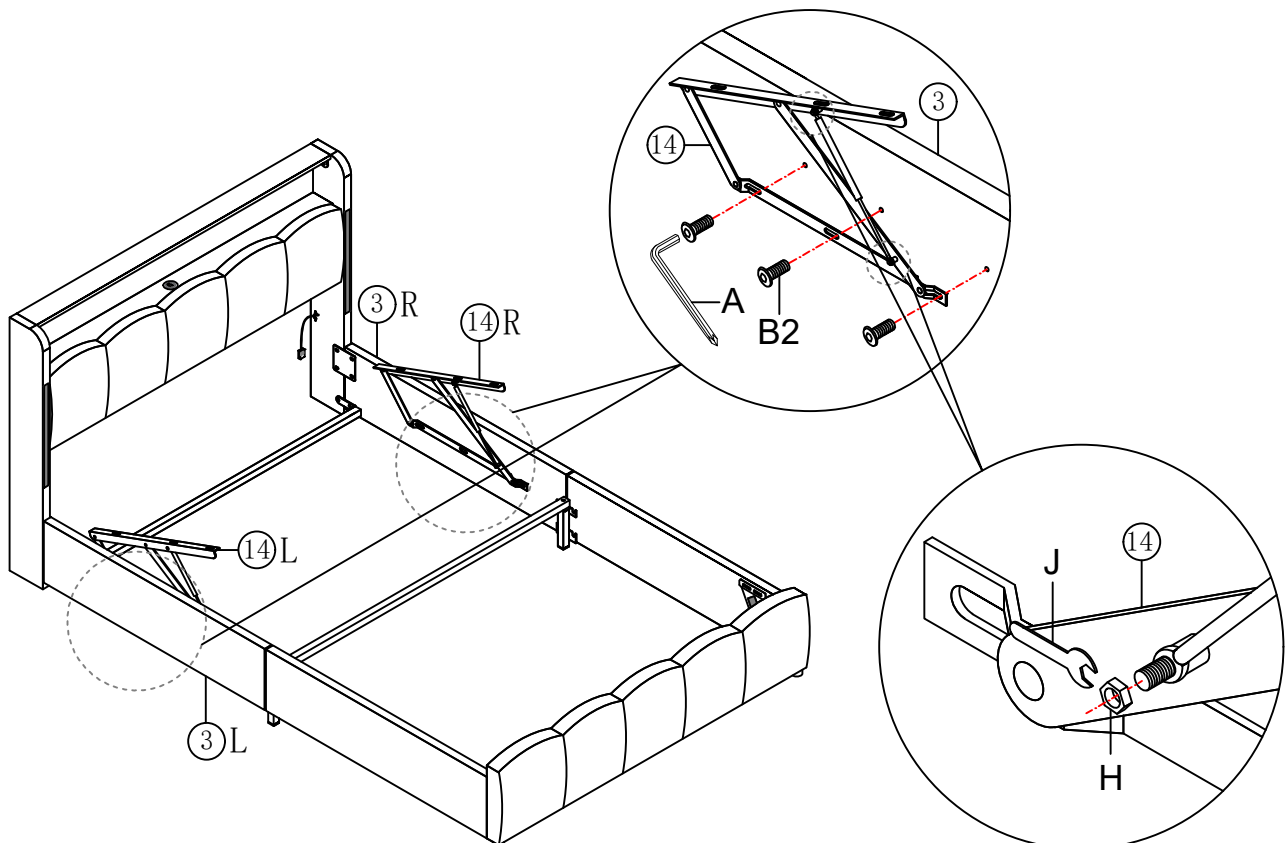

Schritt 22:

<p>A</p> 	<p>B2</p>  <p>M8x16mm</p> <p>6Stück</p>	<p>C</p>  <p>M8x45mm</p>	<p>H</p>  <p>4Stück</p>	<p>J</p> 
--	--	---	--	--



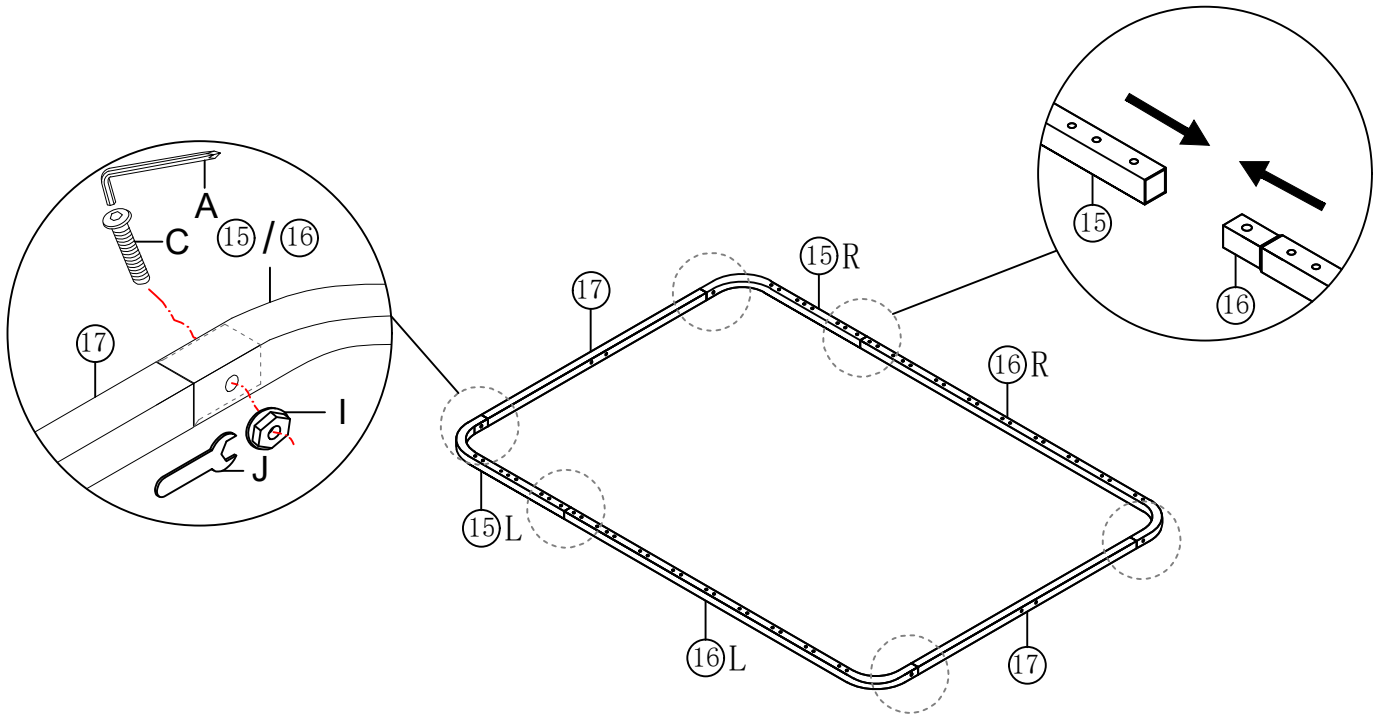

Schritt 23:

<p>A</p> 	<p>C</p>  <p>M8x45mm</p> <p>4Stück</p>	<p>I</p>  <p>4Stück</p>	<p>J</p> 
--	---	--	--





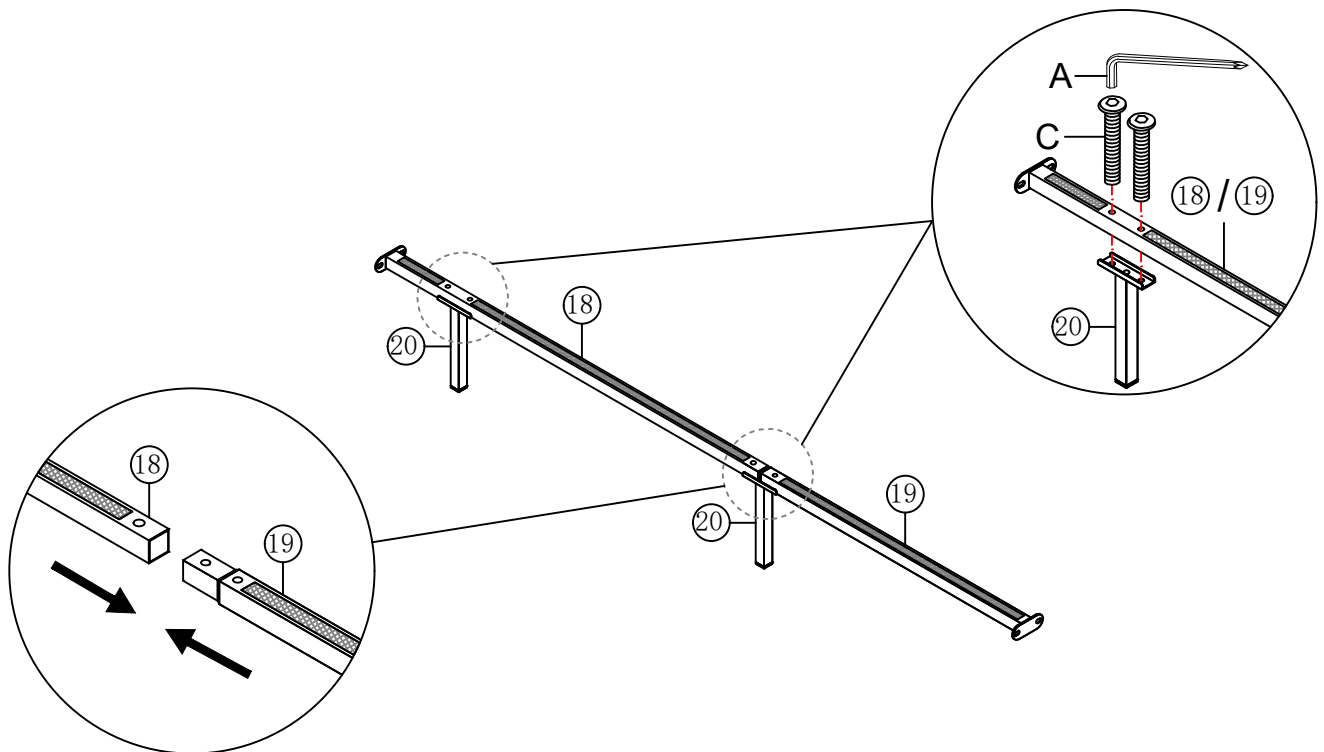

Schritt 24:

<p>A</p> 	<p>C</p>  <p>M8x45mm</p> <p>4Stück</p>
--	---



Schritt 25:

<p>A</p> 	<p>C</p>  <p>M8x45mm</p> <p>4Stück</p>	<p>I</p>  <p>4Stück</p>	<p>J</p> 
--	---	--	--

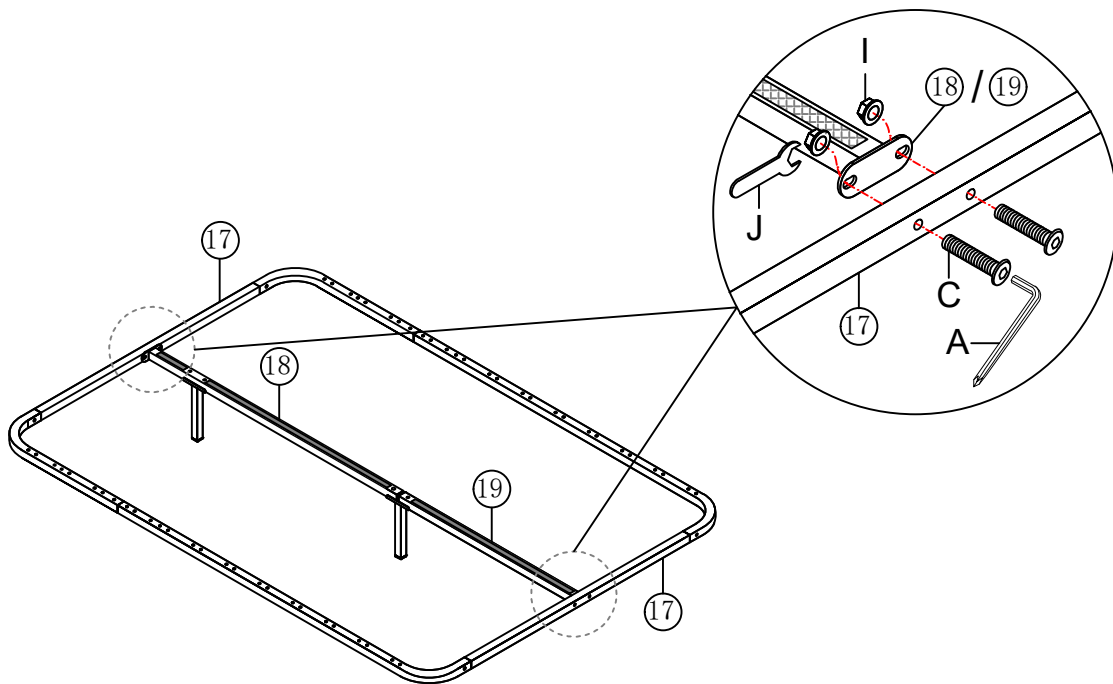



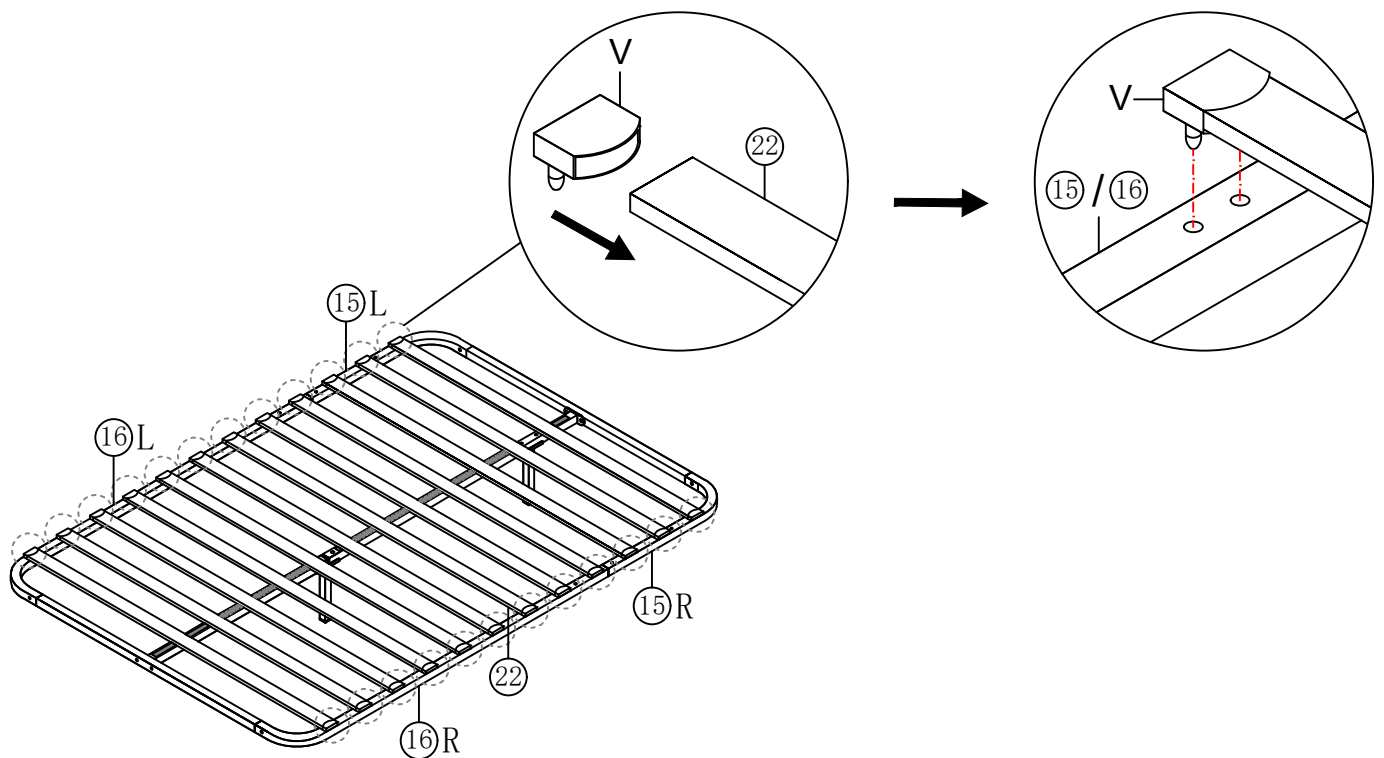

Schritt 26:

<p>V</p>  <p>24Stück</p>



Schritt 27:

A		C	 M8x45mm	I		J		U	
			6Stück		6Stück				1Stück

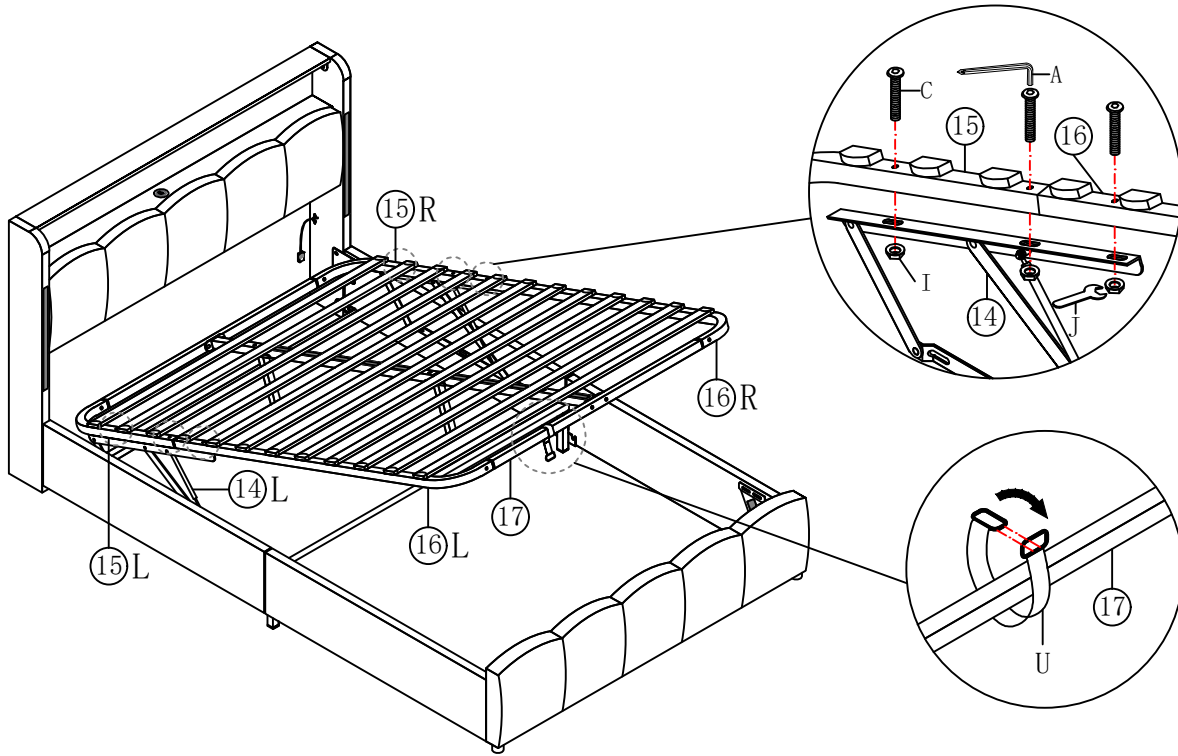

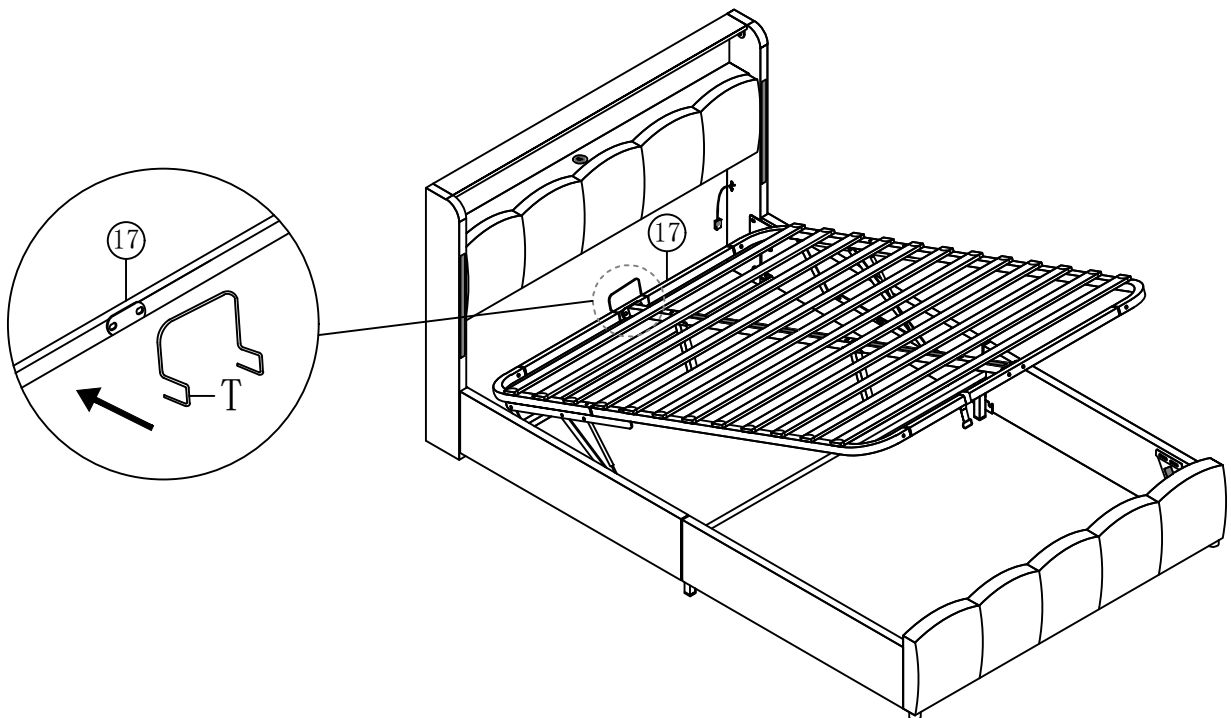

Schritt 28:

T	
	1Stück

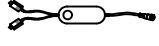

Schritt 29:

W		X	
	1Stück		1Stück

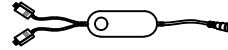

Reminder: Please control the color through the button switch on the controller or download the APP on your phone. You will see a detailed tutorial on how to control the color through the Bluetooth APP later.

Erinnerung: Bitte steuern Sie die Farbe über den Tastenschalter auf dem Controller oder laden Sie die APP auf Ihrem Mobiltelefon herunter. Sie werden später ein ausführliches Tutorial sehen, wie Sie die Farbe über die Bluetooth-App steuern können.

Rappel: S'il vous plaît contrôler la couleur via le commutateur de bouton sur le contrôleur ou télécharger l'application sur votre téléphone mobile. Vous verrez plus tard un tutoriel détaillé sur la façon de contrôler les couleurs via l'application Bluetooth.

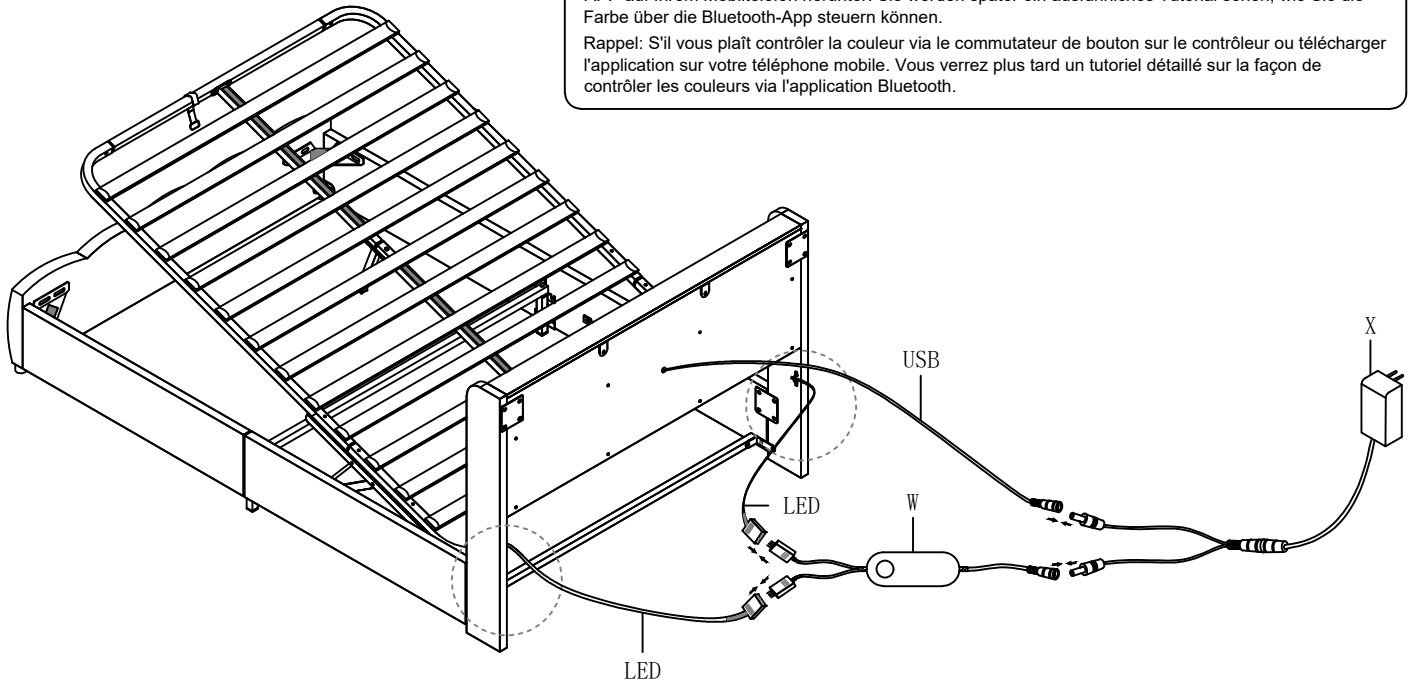

Schritt 30:

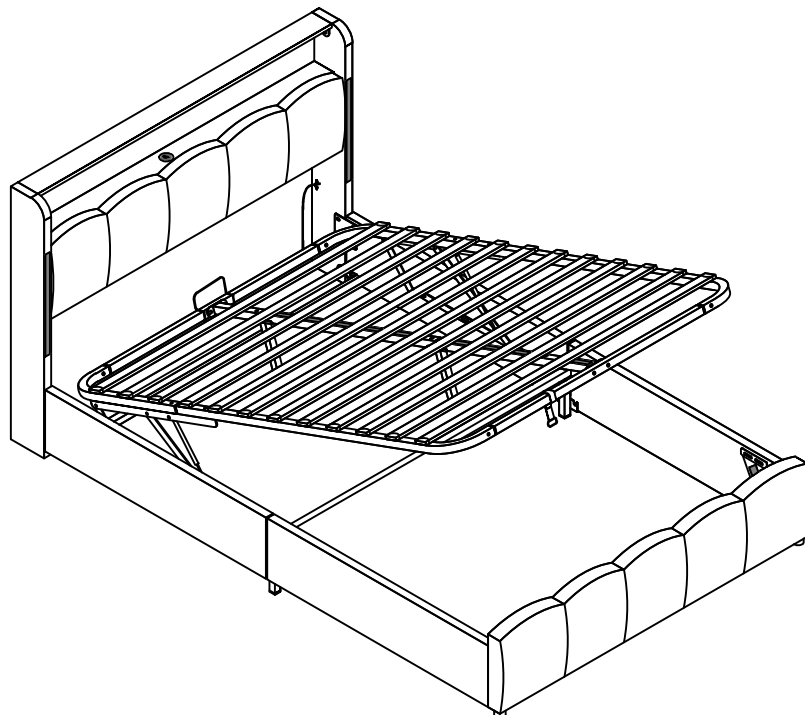

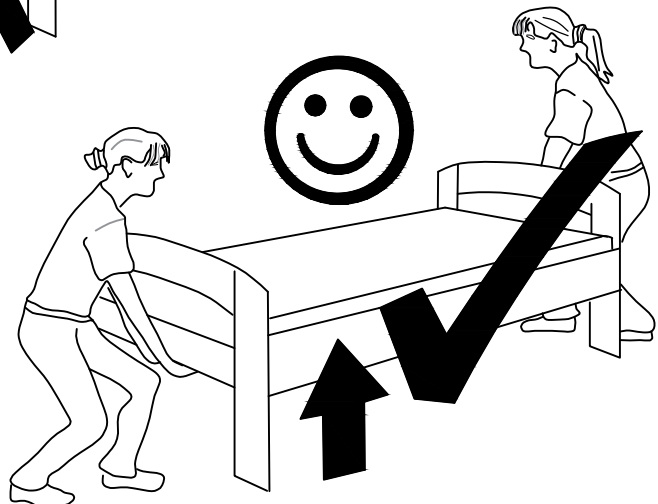
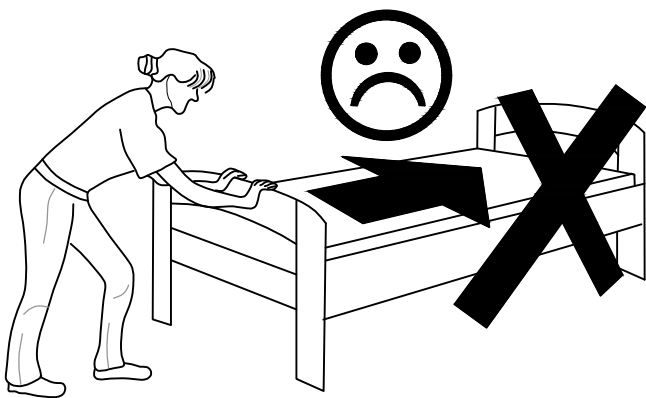
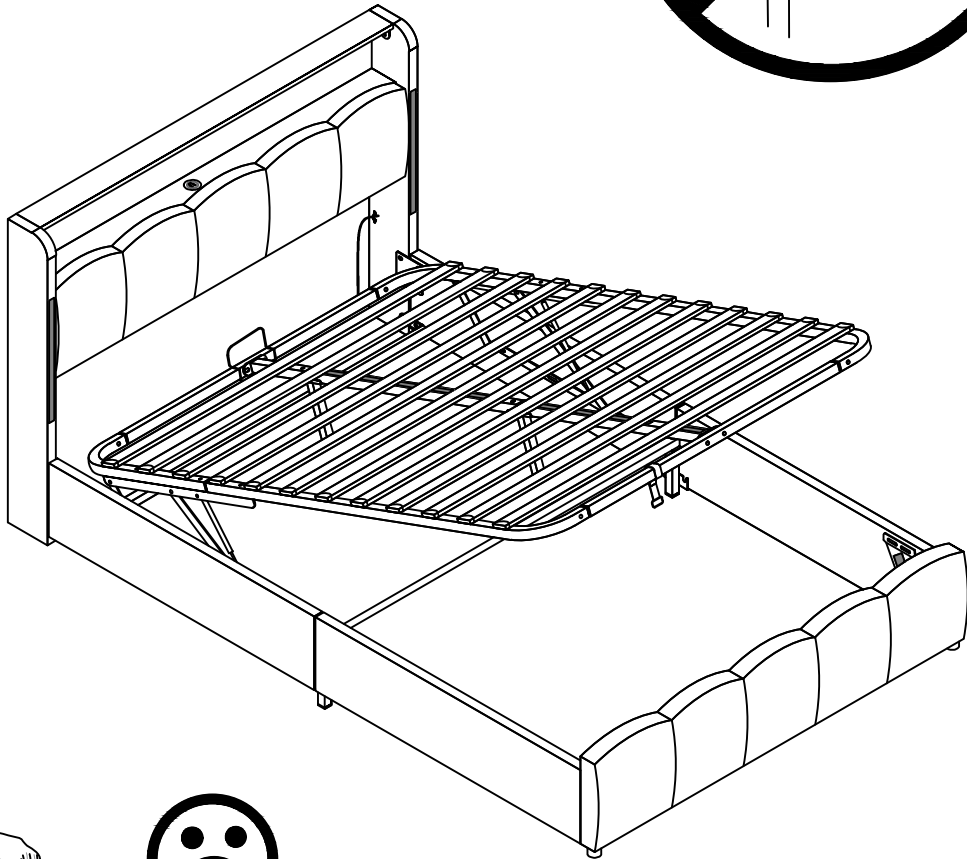

Question: What to do if the slat frame is tilted?

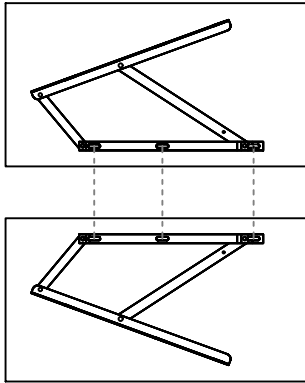

Answer:

The hole on the hydraulic rod is oval. Please make sure that the installation positions on the left and right sides are the same. If you accidentally install one side of the hydraulic rod in the front and the other side in the back, the slat frame will be crooked and you will need to disassemble it and reinstall it.

Das Loch an der Hydraulikstange ist oval. Bitte stellen Sie sicher, dass die Einbaupositionen auf der linken und rechten Seite gleich sind. Wenn Sie versehentlich eine Seite der Hydraulikstange vorne und die andere Seite hinten einbauen, kann dies zu Problemen führen. Der Rahmen der Hydraulikstange ist schief und Sie müssen sie zerlegen und neu installieren.

Question: What to do if the hydraulic system fails to press down?

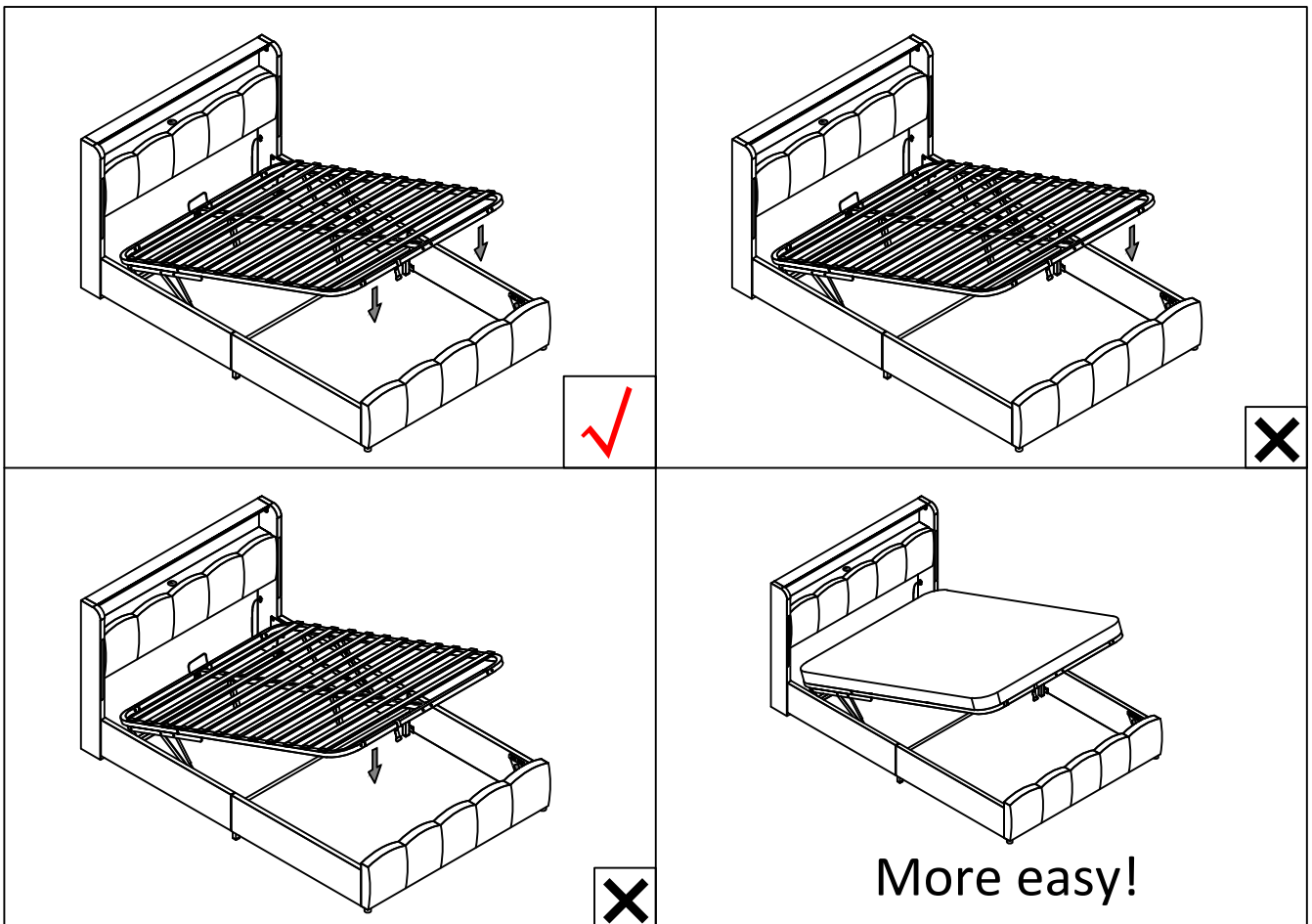

Answer:

When turning off the hydraulic pressure, make sure that the pressure point is at the position indicated by the arrow. Place your hand at the pressure point.

If you place the mattress on a slatted frame, it will be easier to turn off the hydraulic pressure. Please try it.

Do not press only on the left side or only on the right side, as this will damage the hydraulic system.

Stellen Sie beim Abschalten des Hydraulikdrucks sicher, dass sich der Druckpunkt dort befindet, wo der Pfeil anzeigt. Legen Sie Ihre Hände auf die Druckpunkte.

Wenn Sie die Matratze auf einen Lattenrost legen, lässt sich der hydraulische Druck leichter abstellen. Bitte probieren Sie es aus.

Drücken Sie nicht nur auf die linke oder nur die rechte Seite, da dies zu Schäden am Hydrauliksystem führen kann.

LED Bluetooth controller Features

Caractéristiques du contrôleur Bluetooth LED

LED Bluetooth Controller Eigenschaften

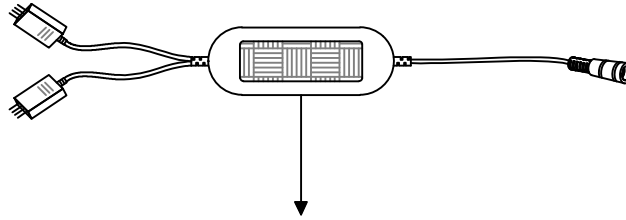

NOTICE:

Please scan the QR code to download the APP to control the color of the light strip.
Please refer to the following instructions for details.

Bitte scannen Sie den QR-Code, um die APP herunterzuladen, um die Farbe des Einzelheiten entnehmen Sie bitte der folgenden Anleitung.

Veillez scanner le code QR pour télécharger l'application pour contrôler la couleur de la bande lumineuse.

Veillez consulter les instructions ci-dessous pour plus de détails.

Click to show the lamp list

Cliquez pour afficher la liste des lumières
Klicken Sie, um die Liste der Lichter anzuzeigen

Switch the color wheel

Basculer la roue des couleurs
Farbrad wechseln

Display the RGB value Click to manual
Afficher les valeurs RVB Cliquez pour
manuellement

RGB-Werte anzeigen Klicken Sie manuell

Adjustment view

Ajuster la vue
Ansicht anpassen

Click to display setting view

Cliquez pour afficher la vue des paramètres
Klicken Sie, um die Einstellungsansicht anzuzeigen

Lamp switch button

Bouton interrupteur lumière
Taste für Lichtschalter

Adjust the color

Ajuster la couleur
Farbe anpassen

Click to shift the interface

Cliquez sur l'interface mobile Ansicht
Klicken Sie, um die Schnittstelle zu wechseln

Click square icon to

Cliquez sur l'icône du carré pour
Klicken Sie auf das quadratische Symbol, um

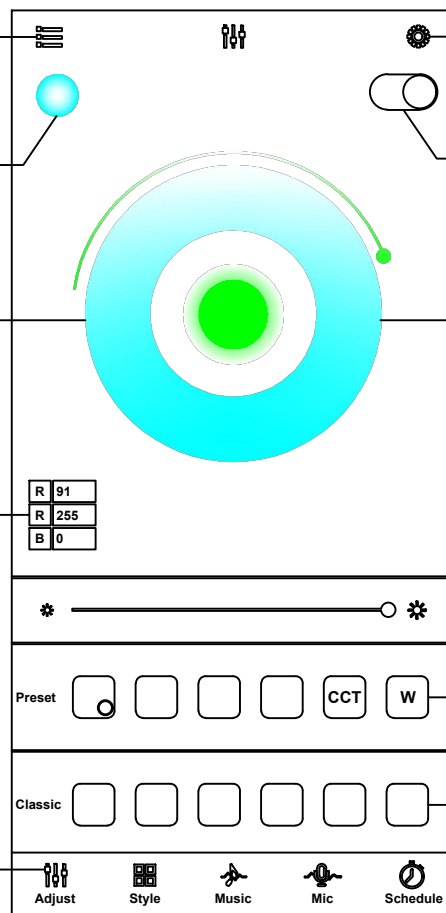

LED Bluetooth controller Features

Caractéristiques du contrôleur Bluetooth LED

LED Bluetooth Controller Eigenschaften

Product Features :

LED Bluetooth controller is directly via mobile phone control remote distance can reach 20m without the need to set up, easy to connect open the software within 5 seconds you can automatically connect the controller · Flow the rhythm of the music changes · Group control · Brightness, speed addition and subtraction · Maximum can be 10 meters RGB(W) strip · The software shows that the text is based on the language of the mobile phone set up automatic transformation of Chinese and English Animation Effect: · Colorful gradient ● All kinds of monochrome, double color gradient ● All kinds of monochrome, double color, colorful flashing Follow the rhythm of the music changes
Product Parameters: · Bluetooth: BLE V4.2 · Input Voltage: 4.5~26V · Working Temp: -25~75
· Size: 43*22*11mm · Weight: 30g · Max Power: 144W(24V)

Caractéristiques du produit:

Le contrôleur Bluetooth LED est contrôlé directement via le téléphone portable La distance à distance peut atteindre 20m Aucun réglage requis, connexion facile Ouvrez le logiciel pour se connecter automatiquement au contrôleur dans les 5 secondes · Changement de rythme de la musique fluide · Contrôle de groupe · Luminosité, augmentation et diminution de vitesse · Jusqu'à 10 mètres barres RVB (W) · Le logiciel affiche le texte Convertir automatiquement les effets d'animation chinois et anglais selon les paramètres de langue du téléphone portable: · Dégradé coloré ● Divers dégradés monochrome et bicolore ● Divers clignotements monochrome, bicolore et colorés suivent le rythme de la musique changes Paramètres du produit: · Bluetooth: BLE V4.2 · Tension d'entrée: 4,5 ~ 26 V · Température de fonctionnement: -25 ~ 75 · Taille: 43 * 22 * 11 mm · Poids: 30 g · Puissance maximale: 144 W (24 V)

Produktmerkmale:

Der LED-Bluetooth-Controller wird direkt über das Mobiltelefon gesteuert. Die Fernentfernung kann bis zu 20 m erreichen. Keine Einstellung erforderlich, einfach zu verbinden. Öffnen Sie die Software, um den Controller automatisch innerhalb von 5 Sekunden zu verbinden · Rhythmusänderungen der fließenden Musik · Gruppensteuerung · Helligkeit, Geschwindigkeitserhöhung und -verringerung · Maximal 10 Meter RGB(W)-Streifen · Software zeigt Text, um den Animationseffekt zwischen Chinesisch und Englisch entsprechend den Spracheinstellungen des Mobiltelefons automatisch umzuwandeln: · Bunter Farbverlauf ● Verschiedene einfarbige und zweifarbige Farbverläufe ● Verschiedene einfarbige, zweifarbige und farbenfrohe Blinkungen folgen dem Rhythmus der Musik changes Produktparameter: · Bluetooth: BLE V4.2 · Eingangsspannung: 4,5 ~ 26 V · Betriebstemperatur: -25 ~ 75 · Größe: 43 * 22 * 11 mm · Gewicht: 30 g · Maximale Leistung: 144 W (24 V)