

Assembly Instruction

| | | | | | | |
|---|---|---|---|---|---|---|
| A  | B  | C  | D  | E  | F  | G  |
| Chair base | Backrest | Armrest | Power cord | Massage control | Lift control | Hardware |

STEP 1

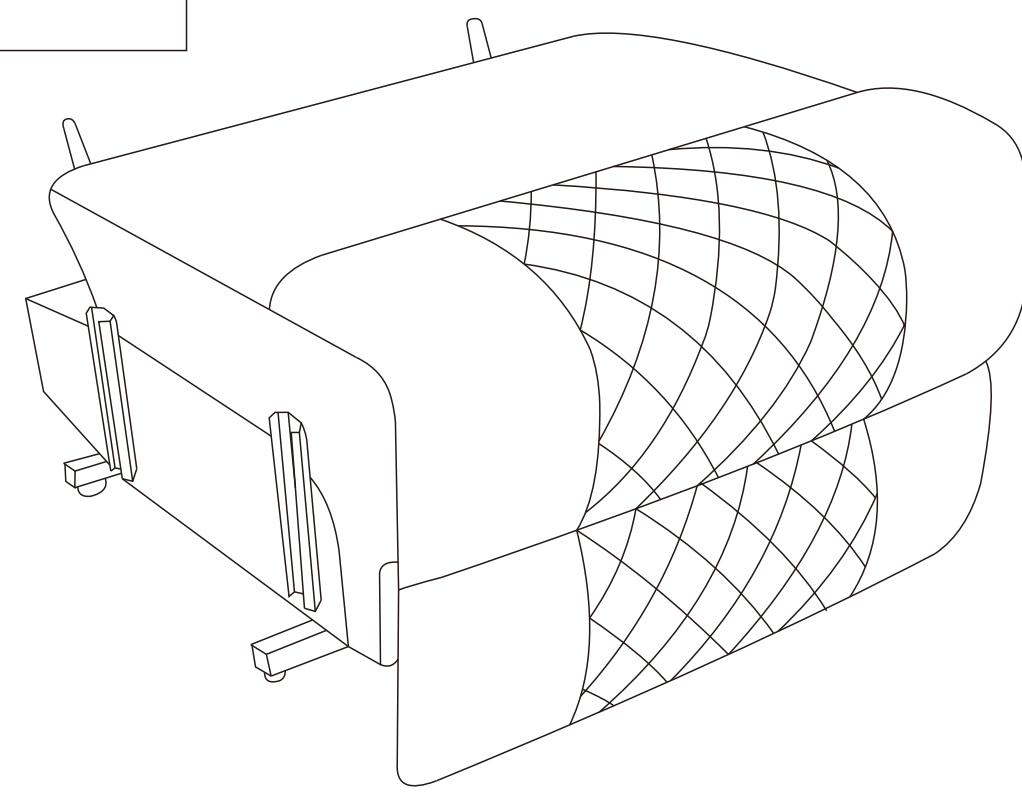
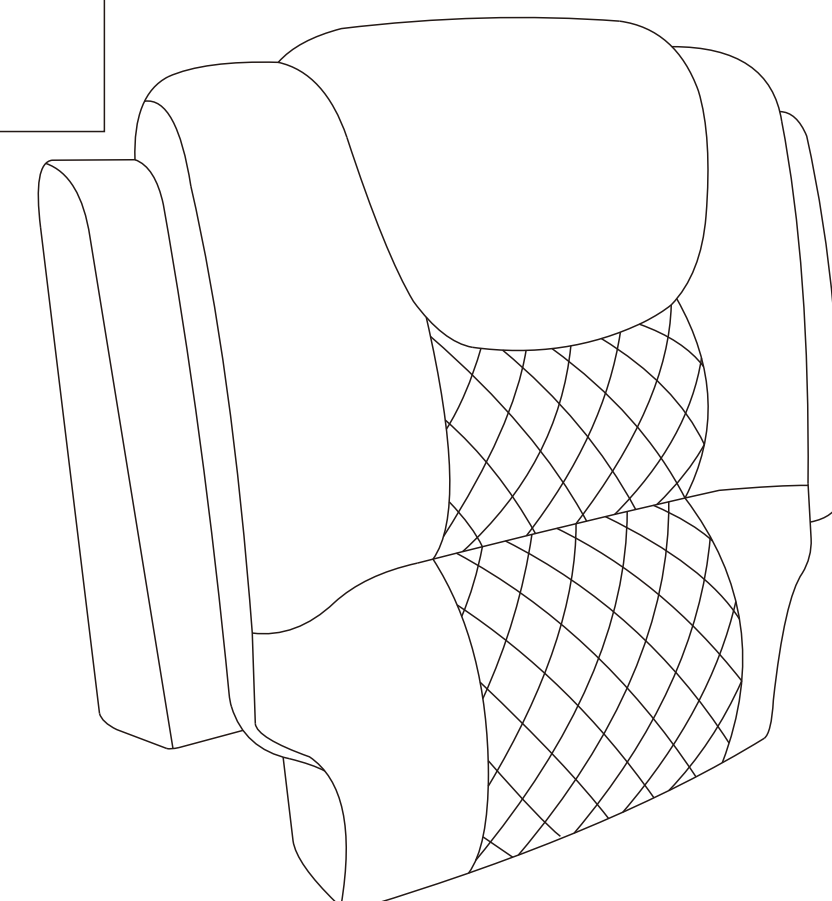
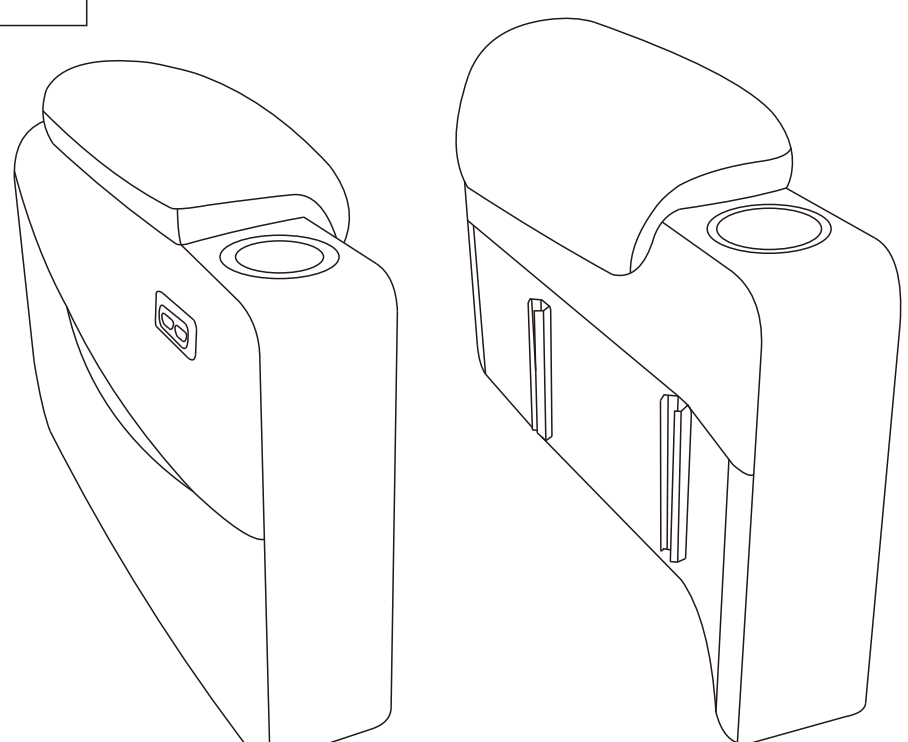
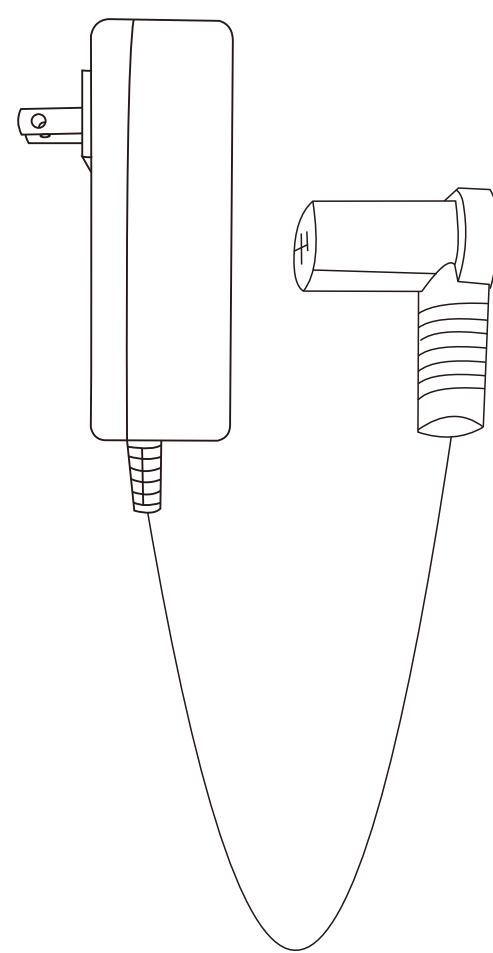
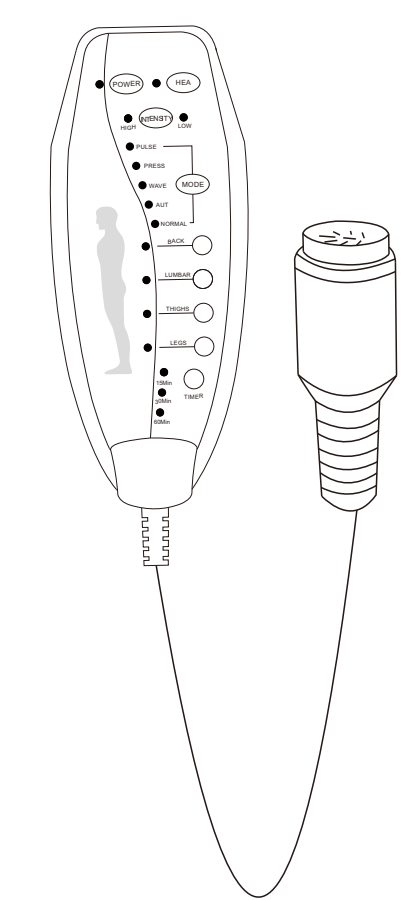
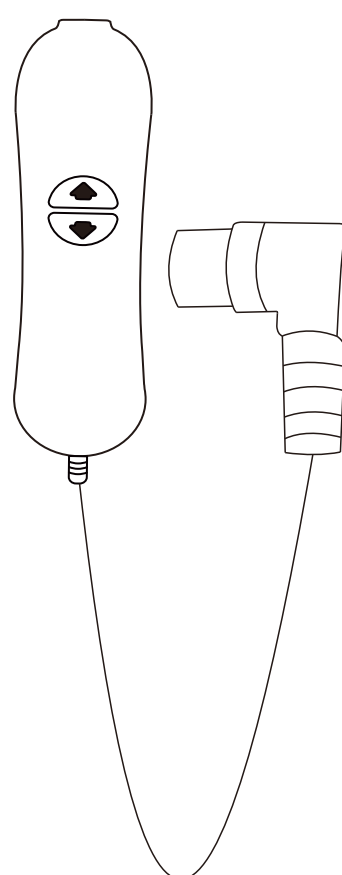
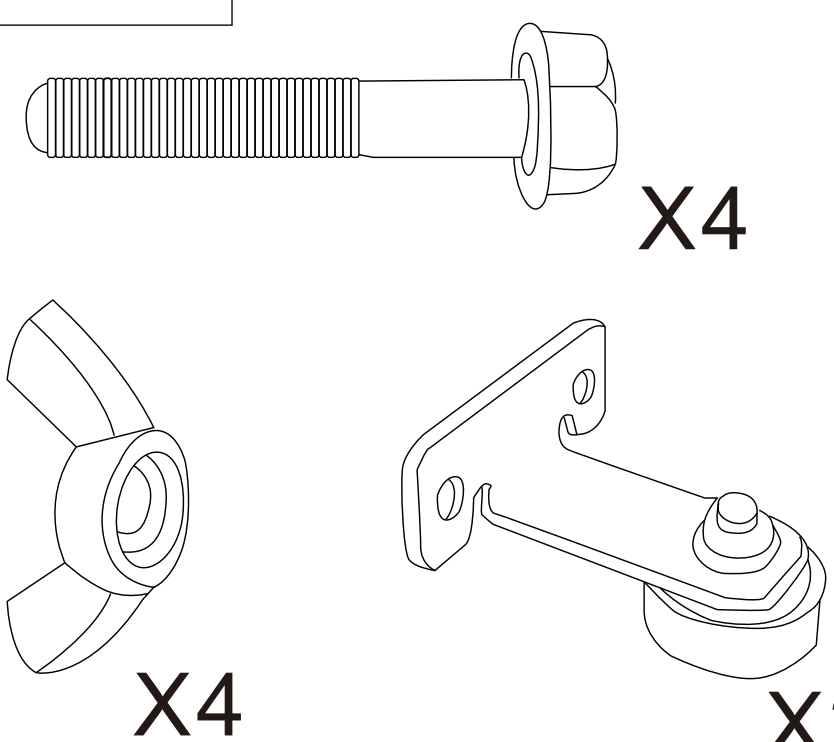
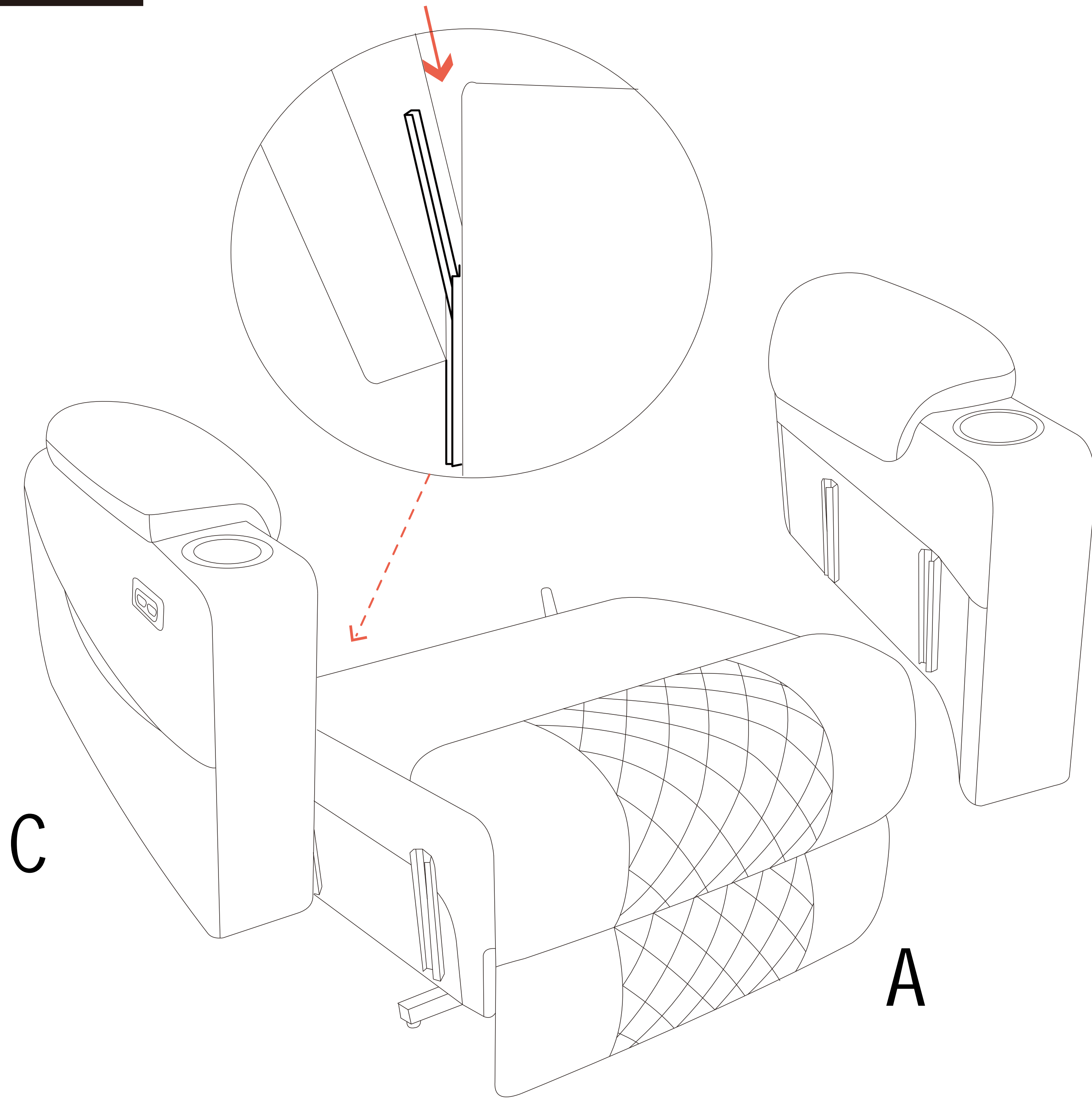

STEP 2

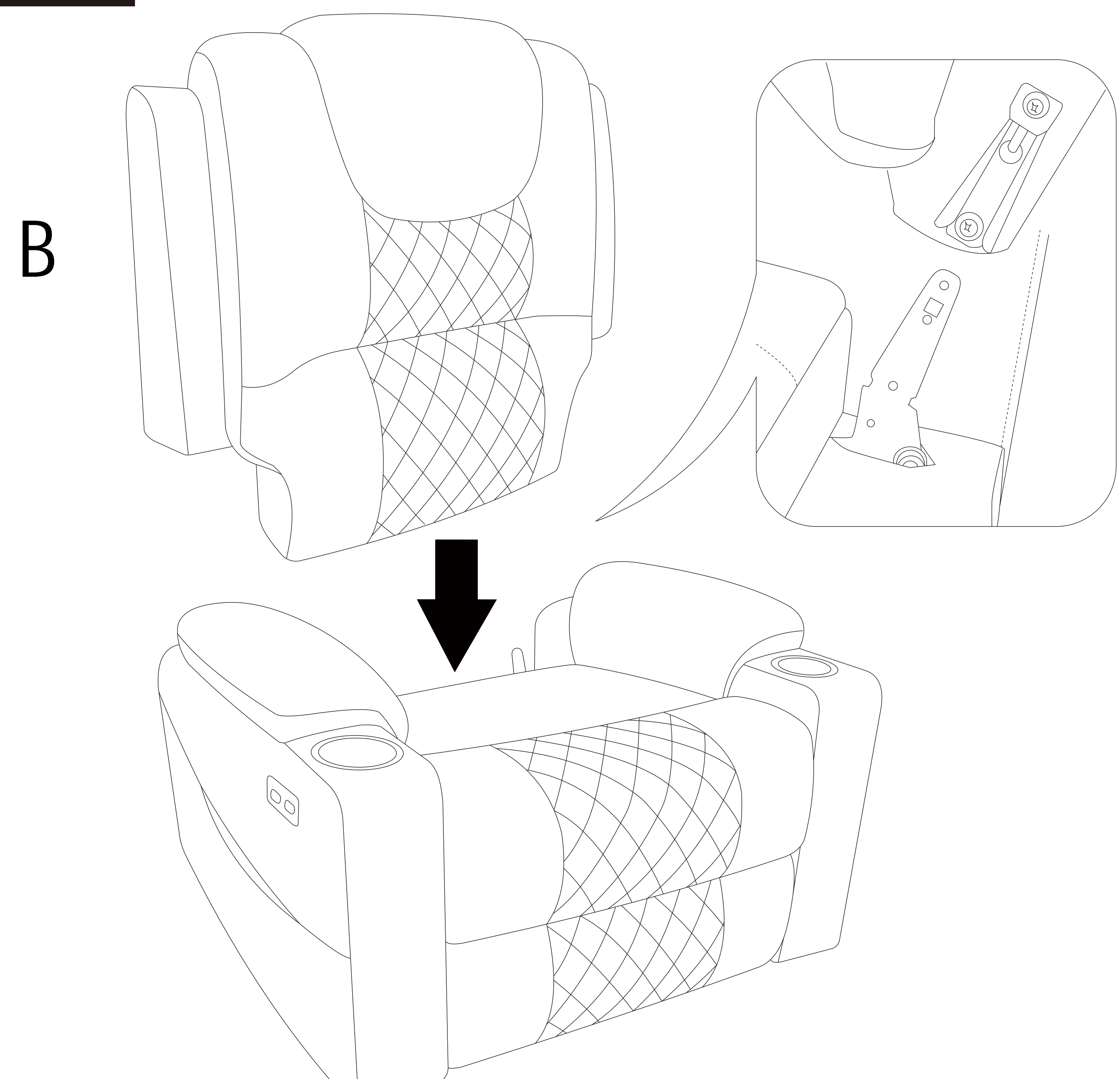

Assembly Instruction

STEP 3

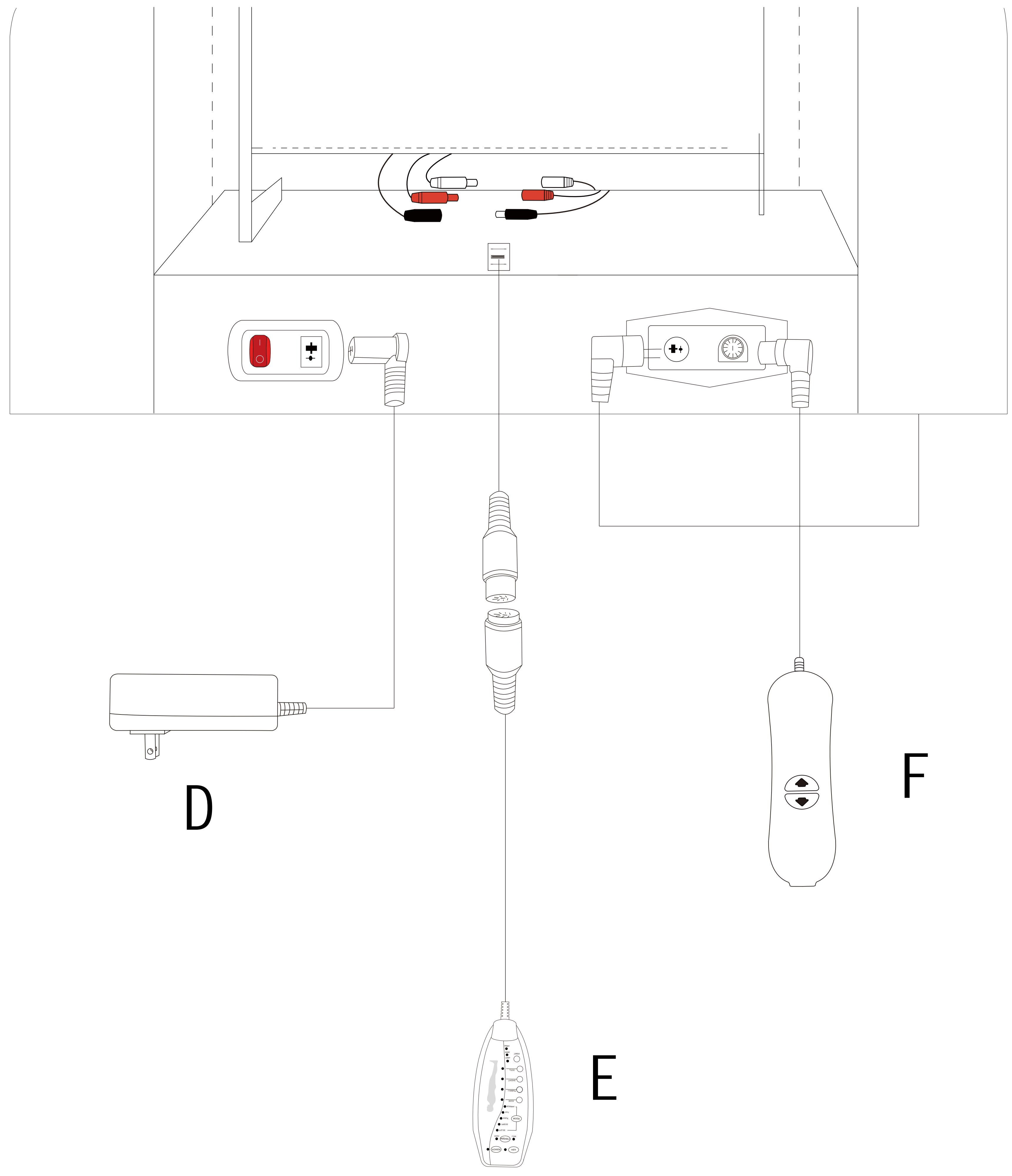

Assembly Instruction

STEP 4

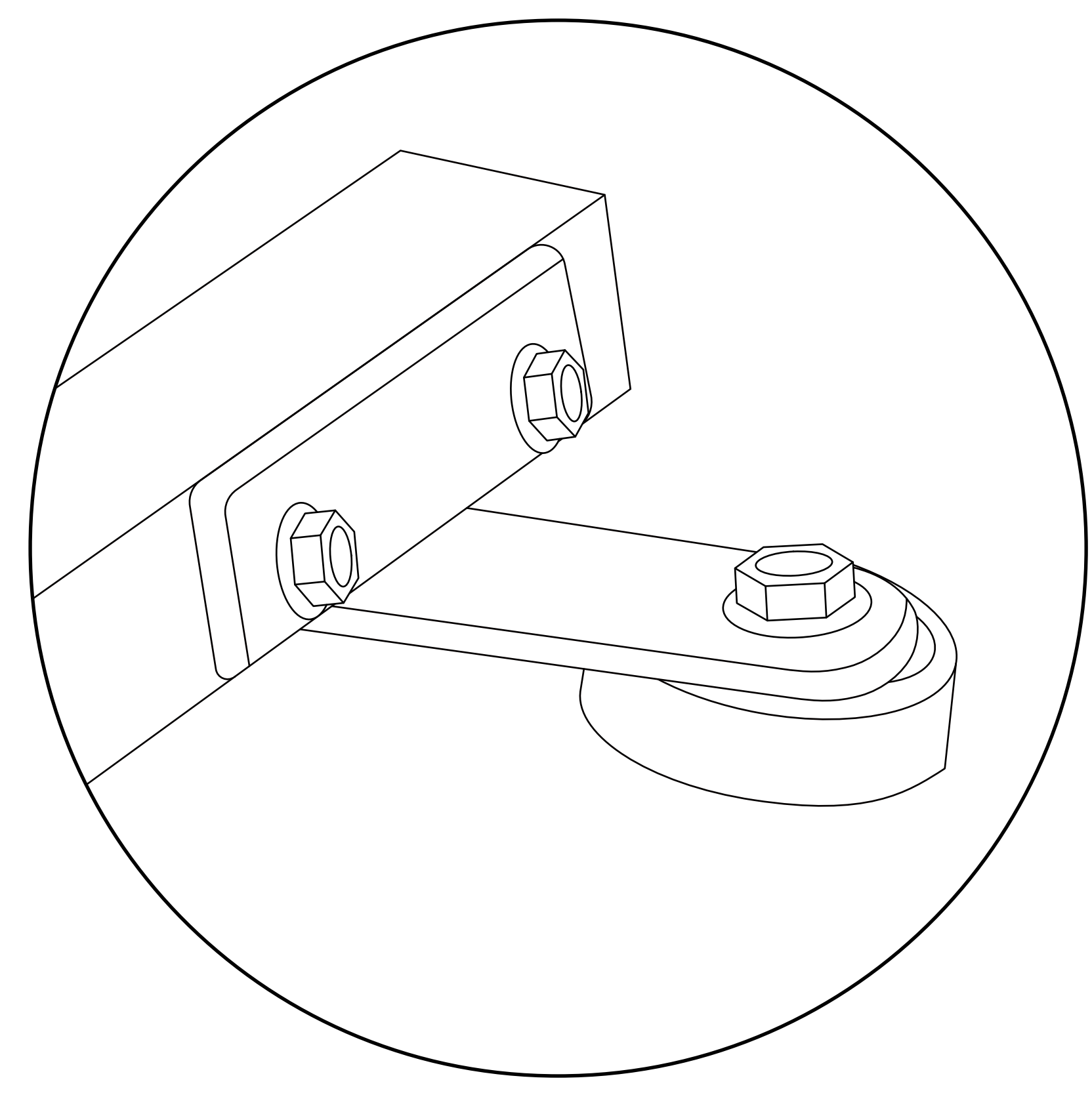
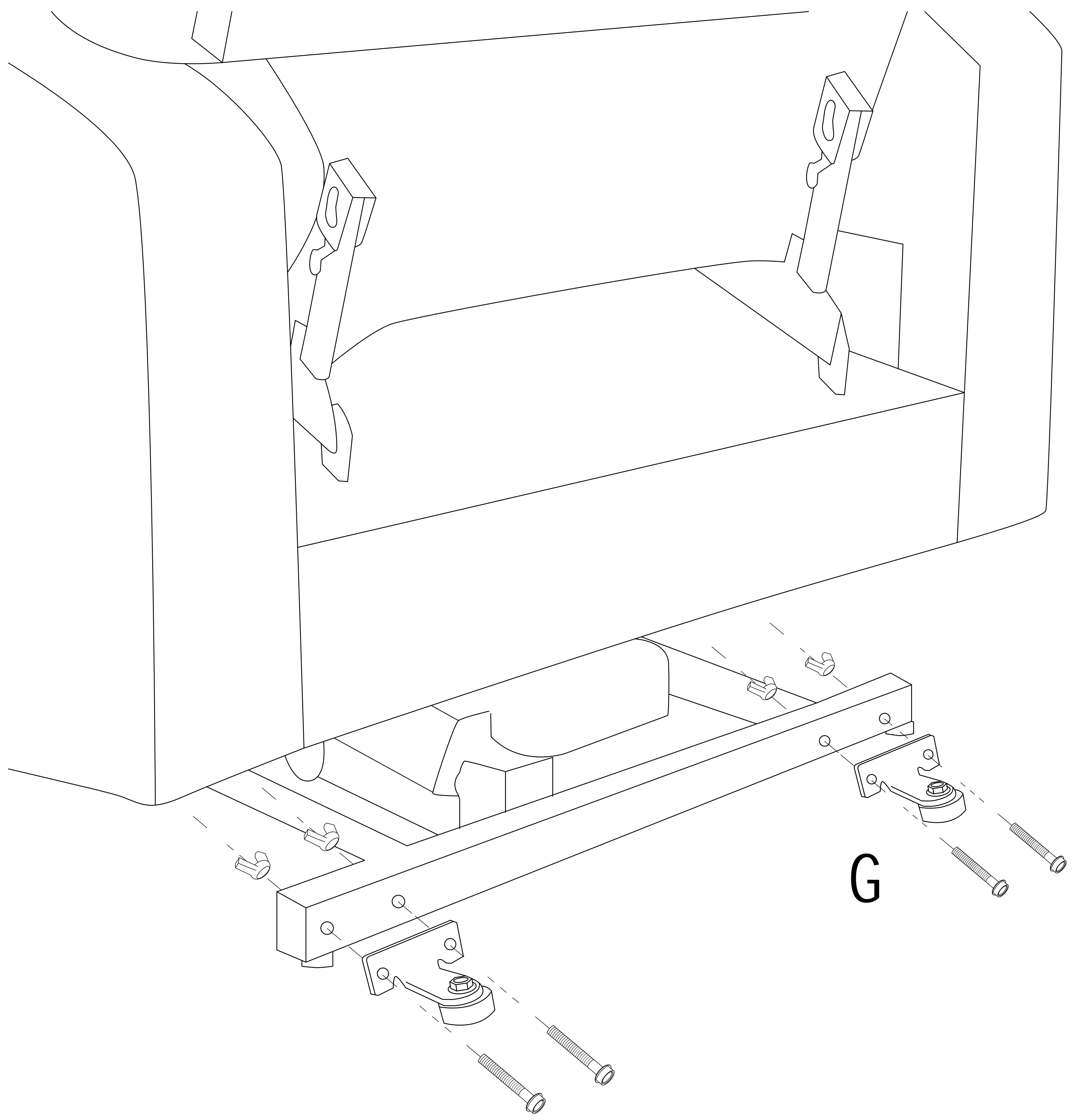

Assembly Instruction

How to recline?

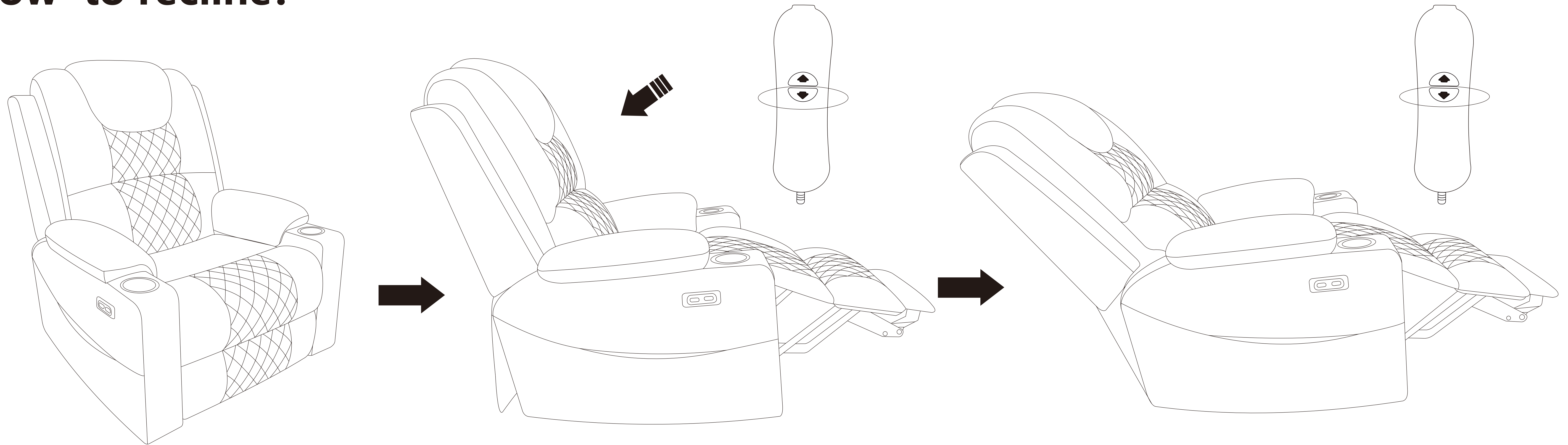

How to get footrest latch down and stand?

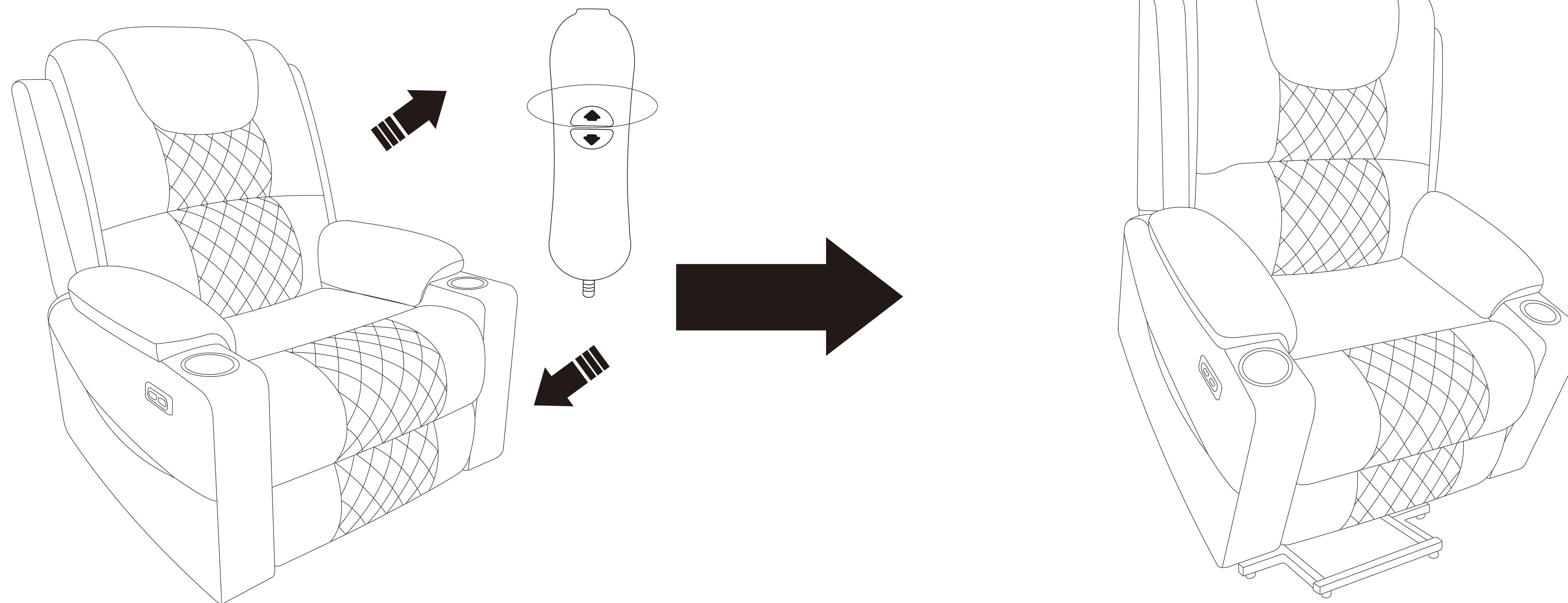

Remote Operation Instruction

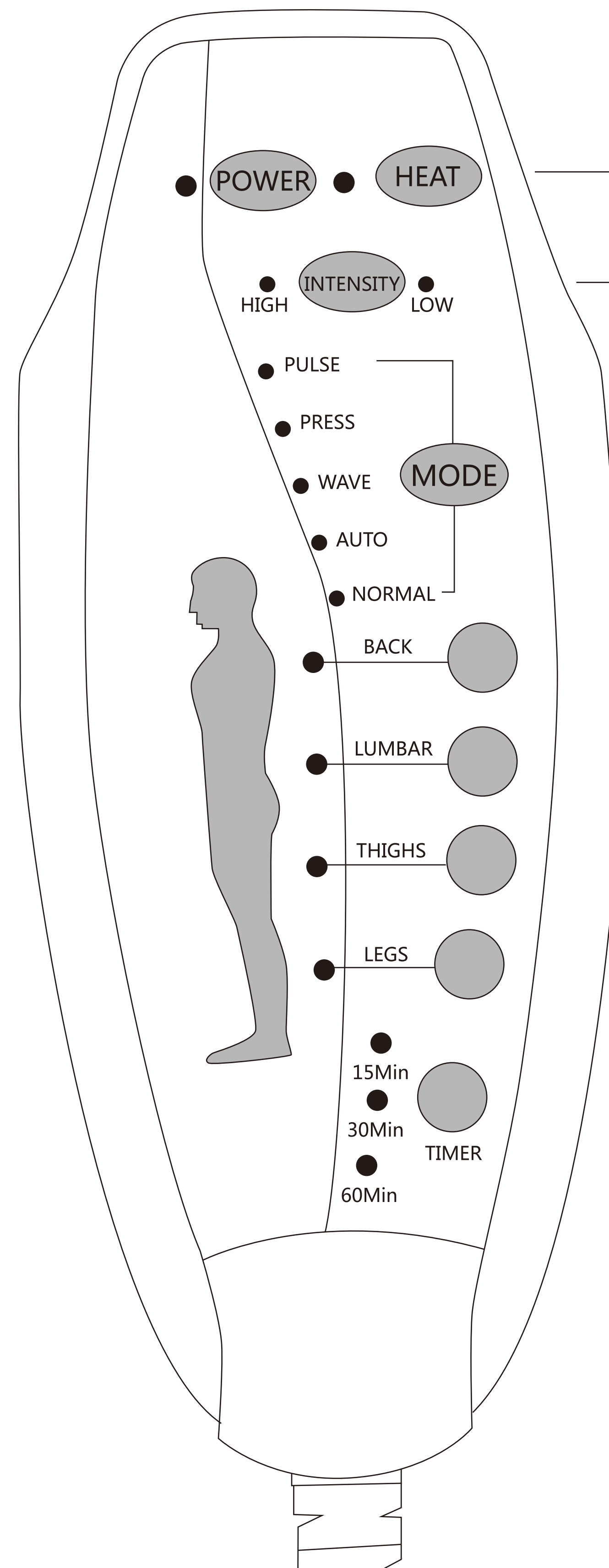

○ POWER: Turn on/off remote control

○ HEAT: Turn on/off heat function for lumbar part only

○ INTENSITY: Control massage function from low to high

○ MODE: Choose one massage mode you like (pulse, press, wave, auto, normal)

○ You can choose 1-4 massage parts (back, lumbar, thighs, legs) to enjoy.

○ TIMER : 15 mins/30 mins/60 mins

Maintenance and Care Methods

- To maintain the recliner's quality, it is recommended to position it at a minimum distance of 30cm from direct exposure to sunlight. Every 10-15 days, it is advisable to utilize a vacuum cleaner to eliminate dust and other particles, ensuring a thorough cleanliness of the recliner.
- To ensure the everlasting smooth quality of the fabric, it is crucial to promptly address any stains before resorting to scraping or employing other destructive treatments. A protective cover can be placed over the recliner surface as a preventive measure. In case of ink stains, using a gentle white cloth or absorbent paper to carefully wipe them away will effectively remove any residue.
- If you need to use solvent to remove stains, please avoid applying it directly onto the stained area. Instead, pour the solvent onto a clean cloth and then use the cloth to gently blot the stains. To ensure safety, it is recommended to perform a cleaning test on a hidden area at the back before treating the stains. When treating the stains, start wiping them in a circular motion from the outside towards the center, until the stains are completely removed. Finally, immediately after wiping, use a low-power hair dryer to gradually dry the area, starting from the outer edges and moving towards the center.
- When wiping stains, it is important to be gentle and exercise caution, avoiding applying excessive force. To protect your recliner, you can consider using a removable and close-fitting protective cover.
- If you have adorned your sofa with a close-fitting protective cover, clean it by following the guidelines mentioned on the cover using an oxidizer lotion free from bleach. Neglecting to do so may result in an alteration of the texture and hue of the recliner's fabric.

• Regular Vacuuming

Make it a habit to vacuum your recliner at least once a week, giving special attention to the corners where dust tends to accumulate. In case you notice any stains, gently wipe them with a clean cloth dampened in water to prevent leaving behind any marks. For best results, begin wiping from the outer edges of the stain towards the center.

• Effective Cleaning Methods

To clean effectively, start by using warm distilled water to eliminate fat and acid contamination. Moisten a clean cleaning cloth and scrub from seam to seam. For stains that contain protein, such as blood or urine, it is recommended to use ice water. Dry stains usually require scrubbing with a pH neutral soap or thymol. Dilute the foam and apply it to the stain, and if you are dealing with a large area, wash from the outside towards the inside. Afterward, use a clean cloth and diluted distilled water to wipe the surface. To get rid of any remaining moisture, use a dry cloth. In case you come across difficult stains like blood, gum, or ballpoint pen marks, it is advisable to seek professional help or ask for advice on the best method to remove them.

• How to remove stubborn stains

If there is gum or other glue on the recliner, you can use an ice pack or ice water to cool down and then gently wipe off with a fine cloth.

Product Precautions

1. Unpacking and Checking

- Prior to opening the package, it is advisable to examine the package for any signs of damage or tampering. Once unpacked, carefully inspect the product's external condition for any dents, scratches, or other potential issues. Subsequently, ensure that all accompanying accessories are present and accounted for. Avoid utilizing sharp tools during the unpacking process to prevent any unintended harm or damage to the recliner's surface;
- After the product undergoes prolonged transportation over long distances, it is expected that temporary indentations may form. However, it is natural for these indentations to gradually recover after the product is used for a certain period of time.

2. Transportation and Storage

- Before relocating furniture, it is crucial to ensure that items are removed to avoid any potential harm caused by falling components during the furniture moving process. This precautionary measure is vital to ensure the safety of individuals involved.;
- When it comes to relocating furniture, it is essential to lift it carefully and place it in an appropriate position before gently lowering it. During the moving process, it is advisable to refrain from pulling or exerting excessive force to prevent any potential damage, such as loosening or breaking the iron frame and internal structure;
- When you relocate your furniture, it is crucial to ensure that its base is securely grounded in its new position.;
- When disassembled furniture needs to be moved, take it apart and move it.
- When furniture remains idle for an extended duration, it is advisable to shield it using packing materials that are impervious to dust and light. Furthermore, it should be securely positioned within an indoor space that ensures adequate dryness and ventilation.

3. In Use

- Before using furniture, it is important to ensure that it is perfectly levelled.
- It is advisable to refrain from prolonged exposure to sunlight and high-energy lamps, as they can lead to local discoloration or fading.
- Avoid placing any heavy items on the non-load-bearing components of the furniture.
- Connectors, if loose, should be locked in time, prohibit the use of non-locking state.
- Please keep the room ventilated and with normal dryness and humidity to avoid mould and mildew on the body of the recliner.
- When expanding the recliner, please do not put your hands into the iron frame and internal structure to prevent the possibility of hand injuries or pinches;
- Do not sit alone on the armrests or in front of the unfolded seat;3.8. If not used for a long time, the power needs to be cut off;

4. Maintenance

- Try to avoid standing, jumping or sitting hard on your furniture, as this can cause damage to your furniture. Sharp objects (keys, knives) and animal claws can cause damage to your furniture.
- Power off when using wet cloth for maintenance.