

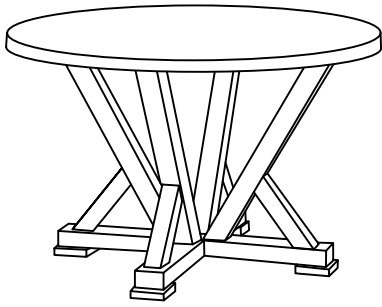





ASSEMBLY INSTRUCTION





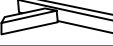

Description: ROUND DINING TABLE



IMPORTANT NOTE :

- Place all wooden parts on a clean and smooth surface such as a rug or carpet to avoid the parts from being scratched.
- Check to be sure that you have all parts and hardware.
- Remove all wrapping materials, including staples & packing straps before you start to assemble.
- Do not tighten all screws/bolts until all completely assembled.
- Keep all hardware parts out of reach of children.

| PARTS LIST | | |
|------------|--|-------|
| NO. | COMPONENT | QTY. |
| 1 | TABLE TOP  | 1 PCS |
| 2 | UPPER MOUNTING PLATE  | 1 PCS |
| 3 | LOWER MOUNTING PLATE  | 1 PCS |
| 4 | LEG ASSEMBLY  | 4 PCS |
| 5 | UPPER LEG BASE  | 1 PCS |
| 6 | LOWER LEG BASE  | 1 PCS |

| HARDWARE LIST | | |
|---------------|---|--------|
| NO. | DESCRIPTION | QTY. |
| A | ALLEN KEY M4 x 100MM  | 1 PCS |
| B | JCBC BOLT M6 x 35MM  | 9 PCS |
| C | JCBC BOLT M6 x 70MM  | 8 PCS |
| D | SPRING WASHER M6 x 13MM  | 16 PCS |
| E | FLAT WASHER M6 x 19MM  | 16 PCS |
| F | ADJUSTABLE LEG LEVELER  | 4 PCS |

STEP 1

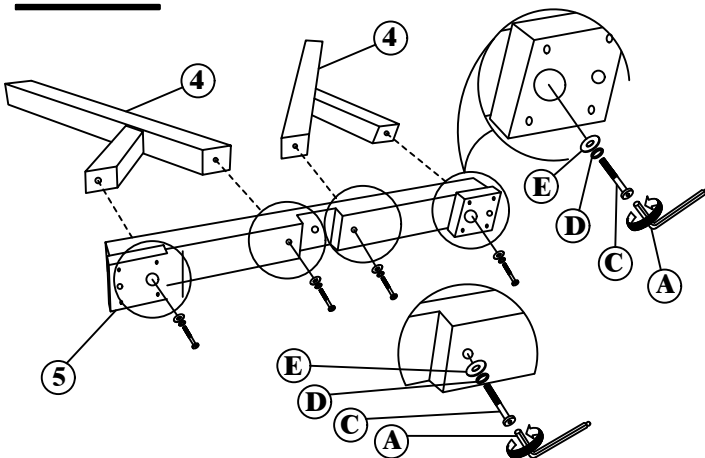

STEP 2

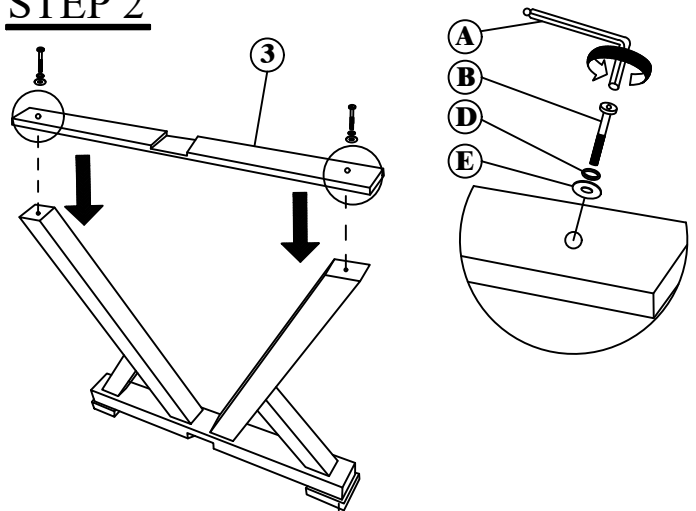

STEP 3

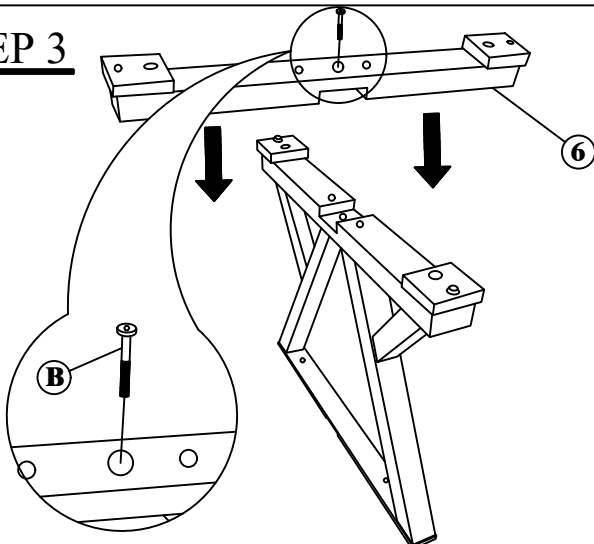

STEP 4

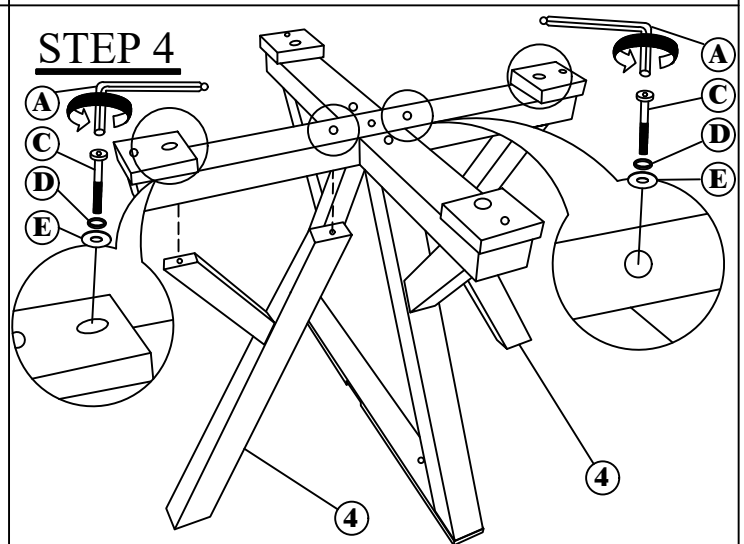

STEP 5

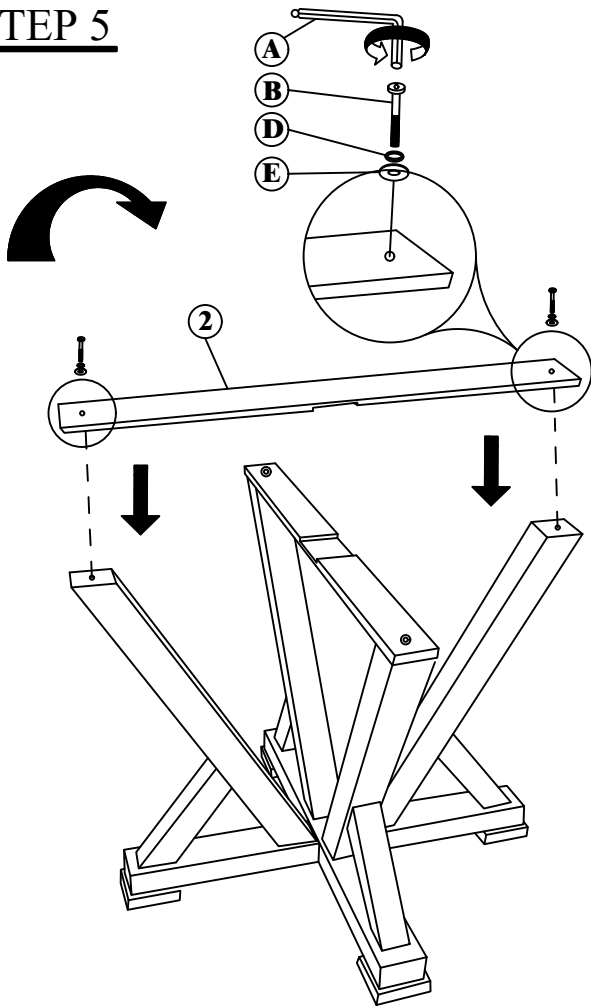

STEP 6

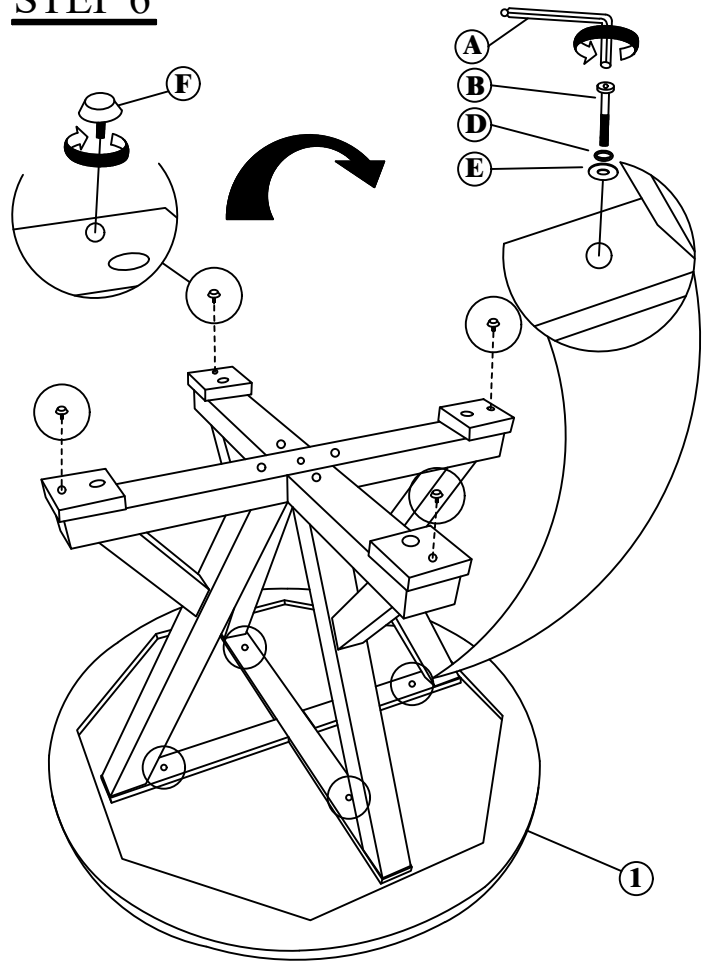

STEP 7

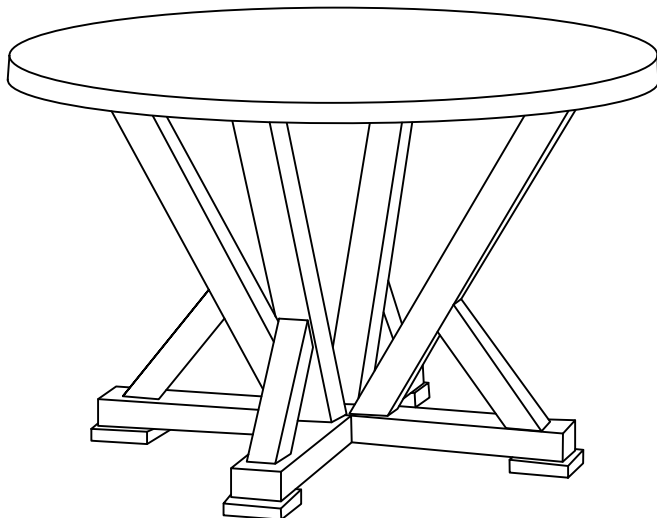
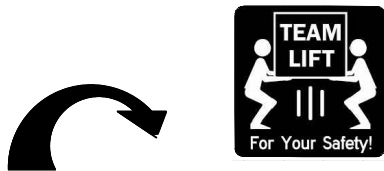

STEP 8

