

ASSEMBLY INSTRUCTIONS

Sort and count your parts!

PARTS LIST			
LETTER CODE	DESCRIPTION	QTY.	PART NO.
(A)	Top	1	1876-03
(B)	Side Shelf	2	1876-04
(C)	Leg Bracket	4	1876-05
(D)	Small Screw	24	1876-24
(E)	Left Shelf Support	2	1876-06
(F)	Right Shelf Support	2	1876-07
(G)	Modesty Panel	1	1876-01
(H)	Leg Frame	2	1876-02
(I)	Large Screw	4	1876-22
(J)	Long Bolt	8	1876-23
(K)	Spacer	8	1876-27
(L)	Acorn Nut	8	1876-21
(M)	Caster without Brake	2	1876-25
(N)	Caster with Brake	2	1876-26

TOOLS REQUIRED: PHILLIPS SCREWDRIVER, WRENCH

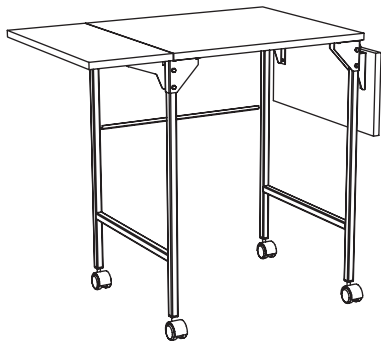

ASSEMBLED UNIT

When ordering replacement parts, please specify color.

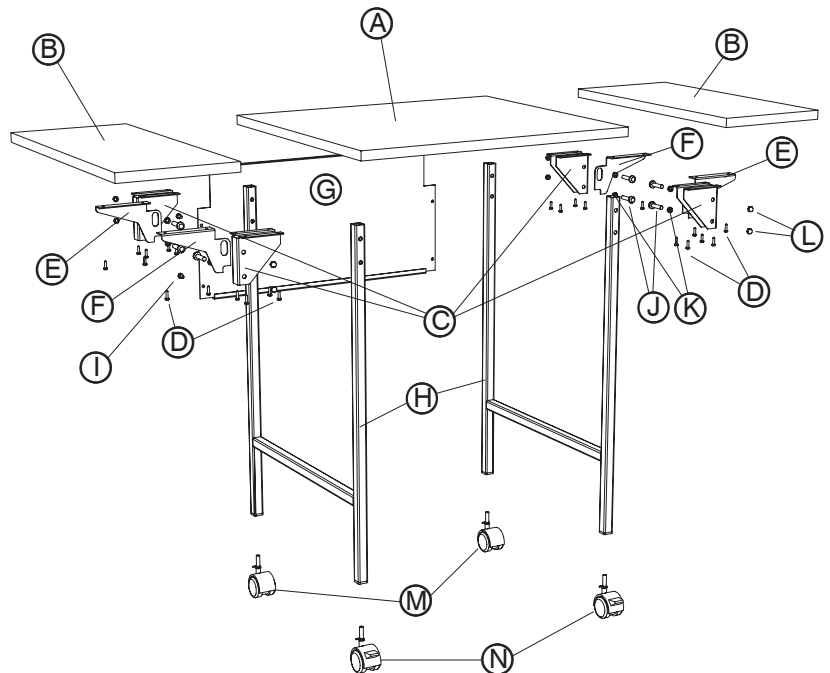

For questions or concerns, please call
Safco Consumer Hot Line 1-800-664-0042
 available Monday-Friday 8:00 AM to 4:30 PM (Central Time)
 (English-speaking operators)

- 1 Lay the (A) Top and (B) Side Shelves face down (holes up) on a clean flat surface. Attach the (C) Leg Brackets to the Top (open end toward the center), using four (D) Small Screws per Bracket. Attach a (E) Left Shelf Support and a (F) Right Shelf Support to each Side Shelf, again using Small Screws. **IMPORTANT: Flanges on these Shelf Supports must face each other!**

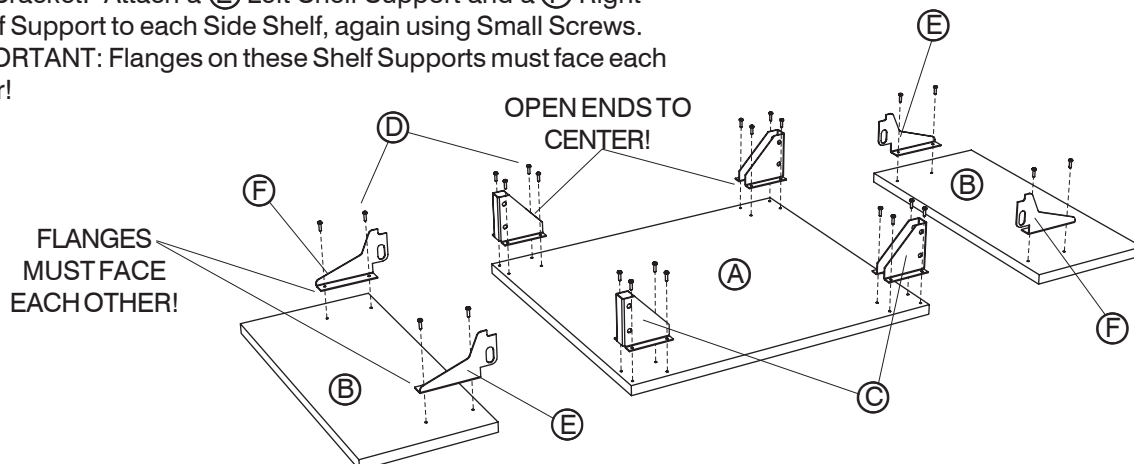

- 2** Attach the **(G)** Modesty Panel to the two **(H)** Leg Frames using **(I)** Large Screws. The notches in the Modesty Panel must face the top of the Leg Frames, and its flanges fit between the Frames.

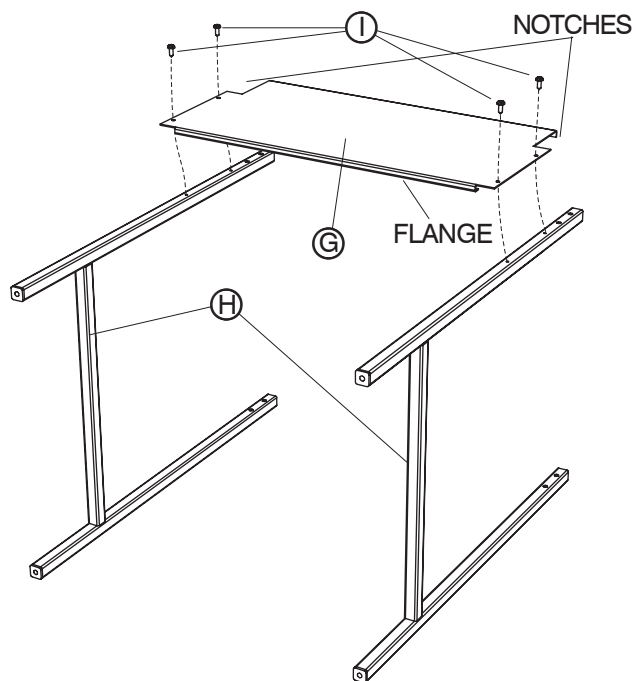

- 3** Carefully lift the leg assembly (upside down) over the Top (also upside down) and insert the ends of the legs into the Brackets. Be certain that the Modesty Panel slides INSIDE the Bracket (see inset).

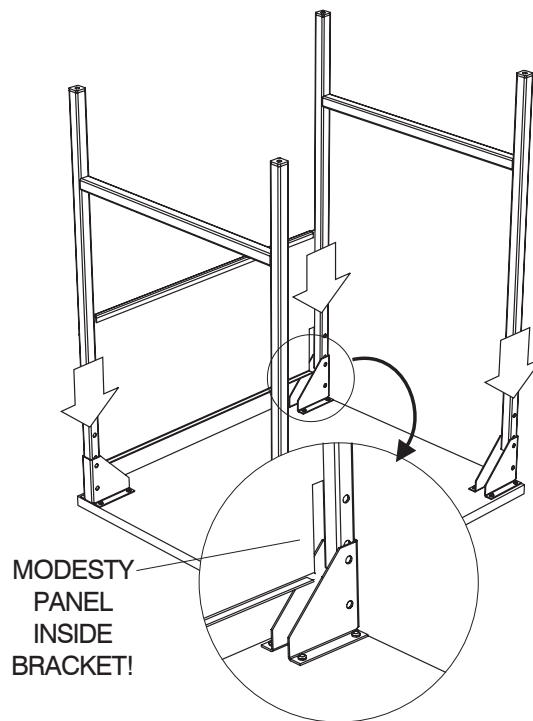

- 4** Align the slots and holes in the Shelf Supports with the holes in the Brackets. Insert a **(J)** Long Bolt through a **(K)** Spacer, then through the slot in the Shelf Support and on through the rest of the leg and Bracket, and fasten with an **(L)** Acorn Nut. The Spacer must fit within the edges of the slot! Insert another Long Bolt and Spacer through the other Bracket hole (the Spacer must fit within the notch) and fasten with an Acorn Nut. Repeat this step with the remaining three legs.

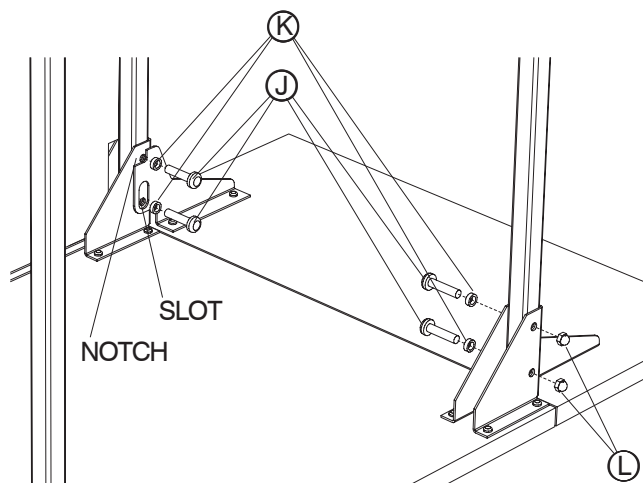

- 5** Push the stems of the **(M)** Casters without Brakes into the rear legs (the ones with the Modesty Panel attached). Install the **(N)** Casters with Brakes into the front legs, and carefully turn the completed unit upright.

