



ASSEMBLY VIDEO



www.eastpointssports.com/32044

DAYTON™

96 in(2.4m) Billiard Table



Model 1-1-32044 (477)

**FOUR OR MORE ADULTS
REQUIRED FOR ASSEMBLY**



www.eastpointssports.com



consumerservice@eastpointssports.com



973-585-4747



Monday to Friday (9am to 5pm EST)

TOOLS

Required

- Wrench - Included
- Level - Not Included

Recommended (Not Required):







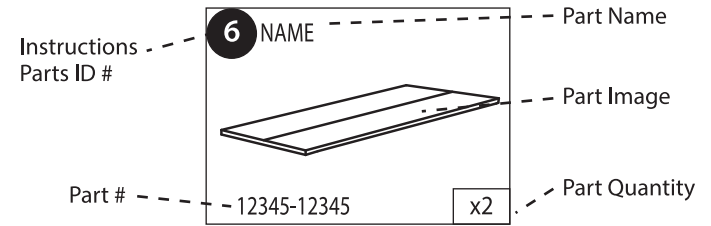

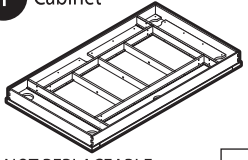

- Electric Screwdriver or Power Driver

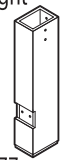
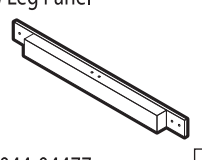
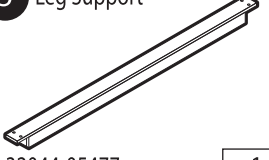
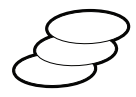
CAUTION: DO NOT OVERTIGHTEN. If using, please make sure that the tool is set to a very low torque to prevent damage to the product.

PARTS IDENTIFIER

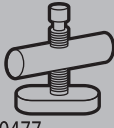
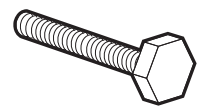

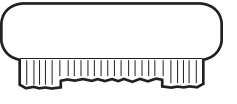
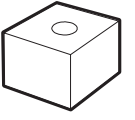
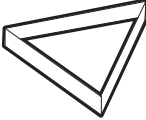
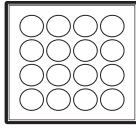
PARTS IDENTIFIER

1 Cabinet  NOT REPLACEABLE x1	2 Leg - Left  32044-02477 x2	3 Leg - Right  32044-03477 x2	4 Leg Panel  32044-04477 x2	5 Leg Support  32044-05477 x1	6 Shim Pack  32044-06477 x1	7 Pocket - Side  32044-07477 x2 PRE-INSTALLED
8 Pocket - End  32044-08477 x4 PRE-INSTALLED	9 U - Bracket  32044-09477 x3 PRE-INSTALLED	10 Surface Leveler  32044-10477 x3 PRE-INSTALLED	60 Bolt  32044-60477 x28	61 Washer  32044-61477 x28	62 Wrench  32044-62477 x1	80 Brush  32044-80477 x1
81 Cue Chalk - Green  32044-81477 x2	82 Triangle  32044-82477 x1	83 Billiard Ball Set - 2.25in  32044-83477 x1	84 Billiard Cue - 57in  32044-84477 x2			

BEFORE BUILDING - Please inspect and lay out all your parts.

Your Table Game Playfield is **NOT** replaceable. Any damage that exits to your playfield is **NOT** repairable under warranty. If your playfield is damaged, the entire game must be returned to the original place of purchase for an exchange. Before you begin assembly be sure to lay out all your parts on a non-marring surface. If using the box, be sure to remove all staples to prevent damage.

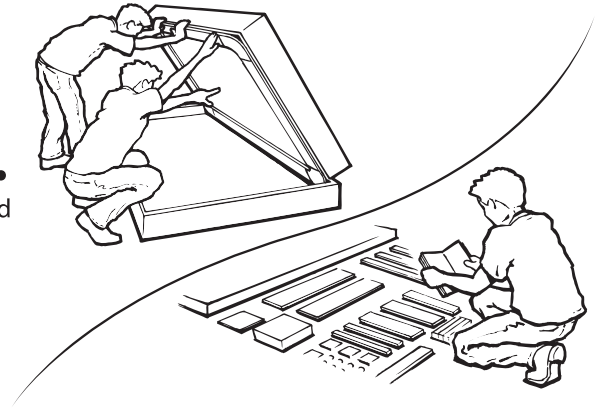

1

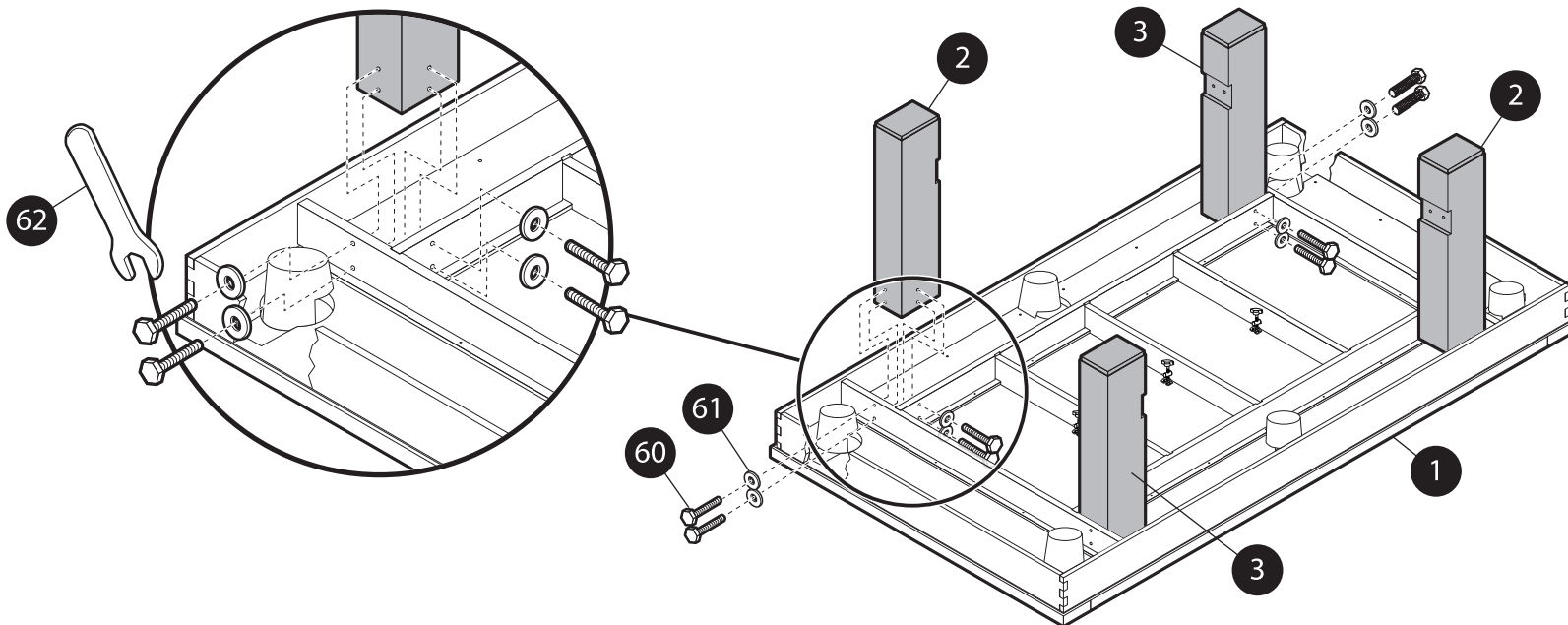

Do Not Overtighten Bolts.

2

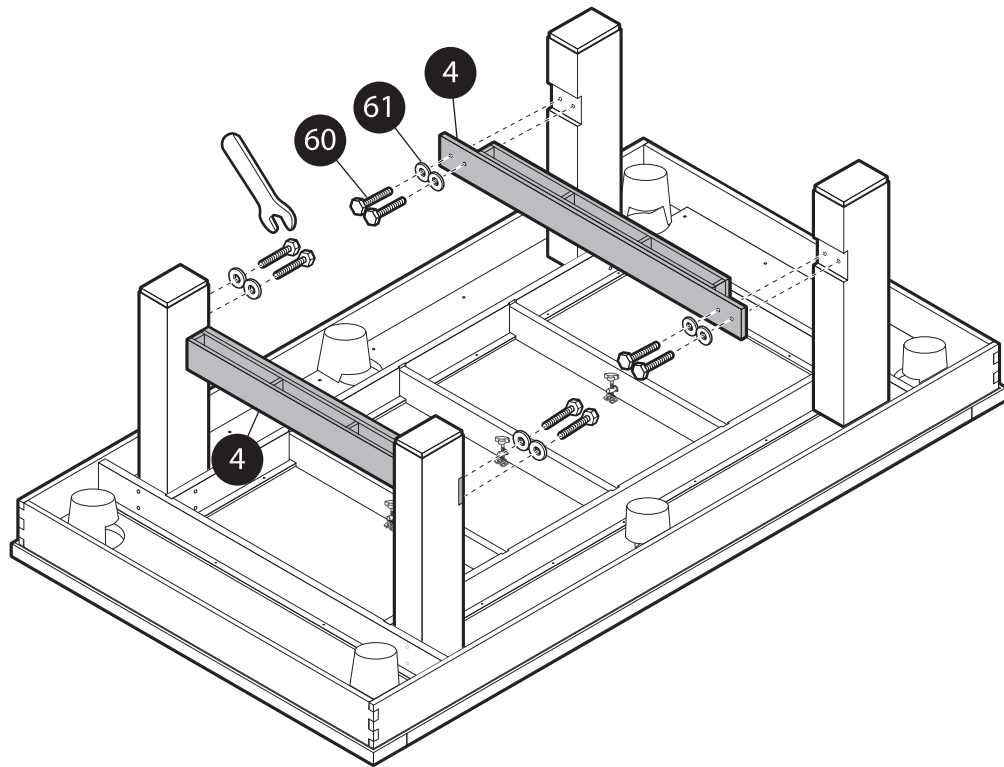

Do Not Overtighten Bolts.

3

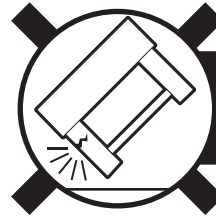

DO NOT
lean table on Legs!



Using at least 4 strong adults pick up and flip table over and place straight down. Avoid sideways pressure to Legs when flipping over.

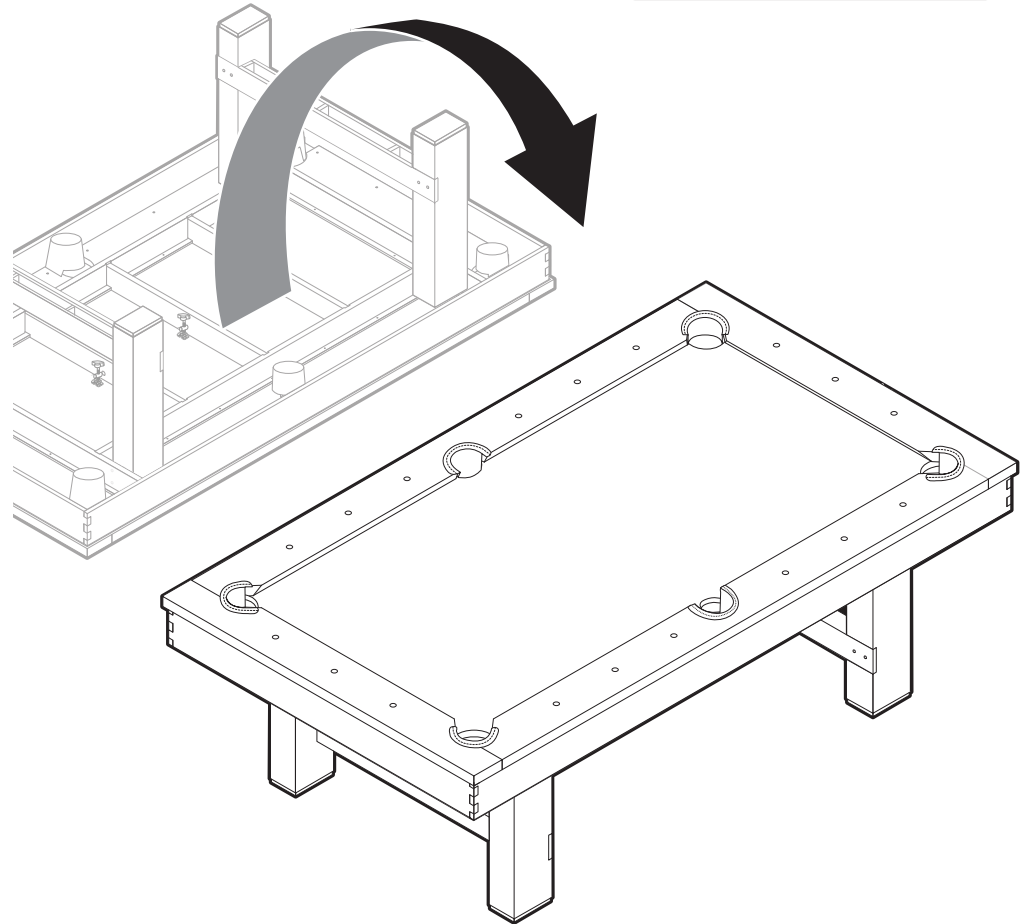

4

Do Not Overtighten Bolts.

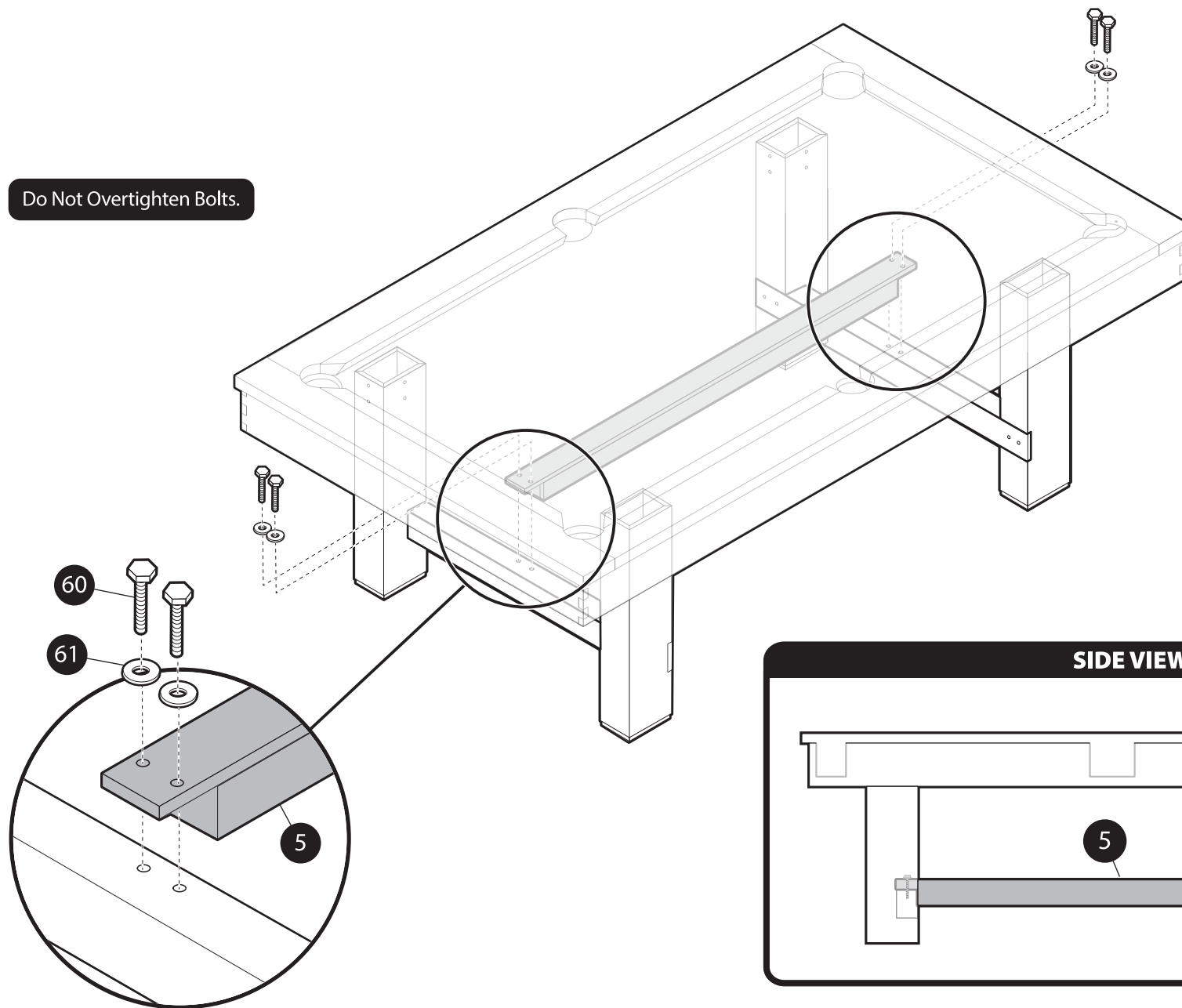

5

Using a Level, check to make sure the Playfield is level. If the Playfield is not level, adjust using the Shim Pack until surface is level.

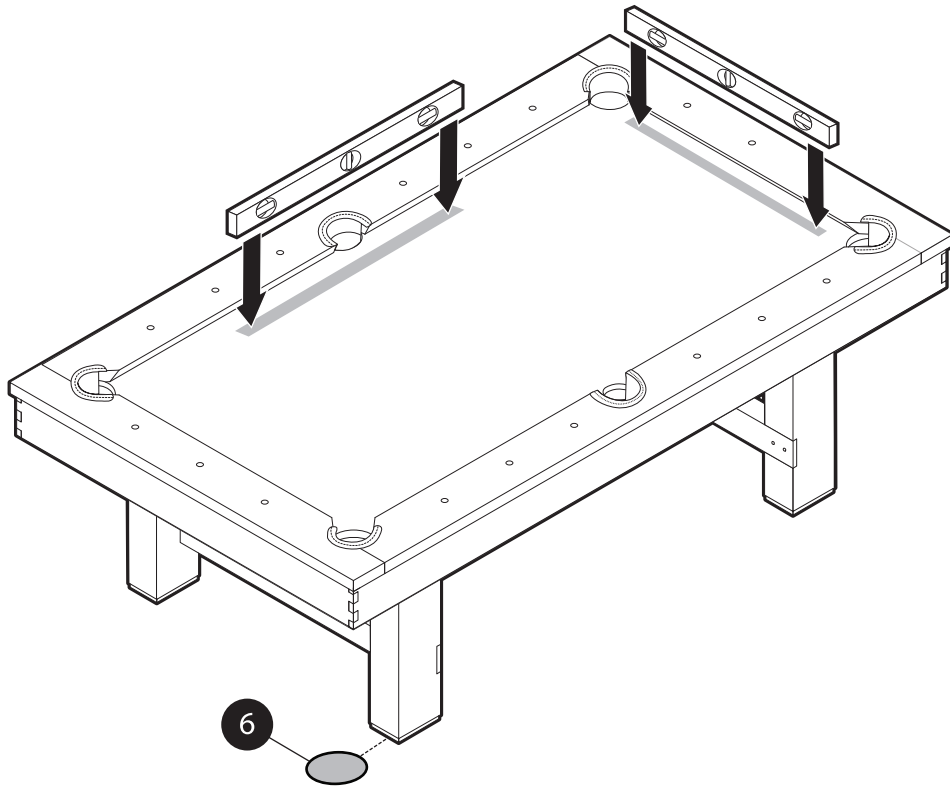

6

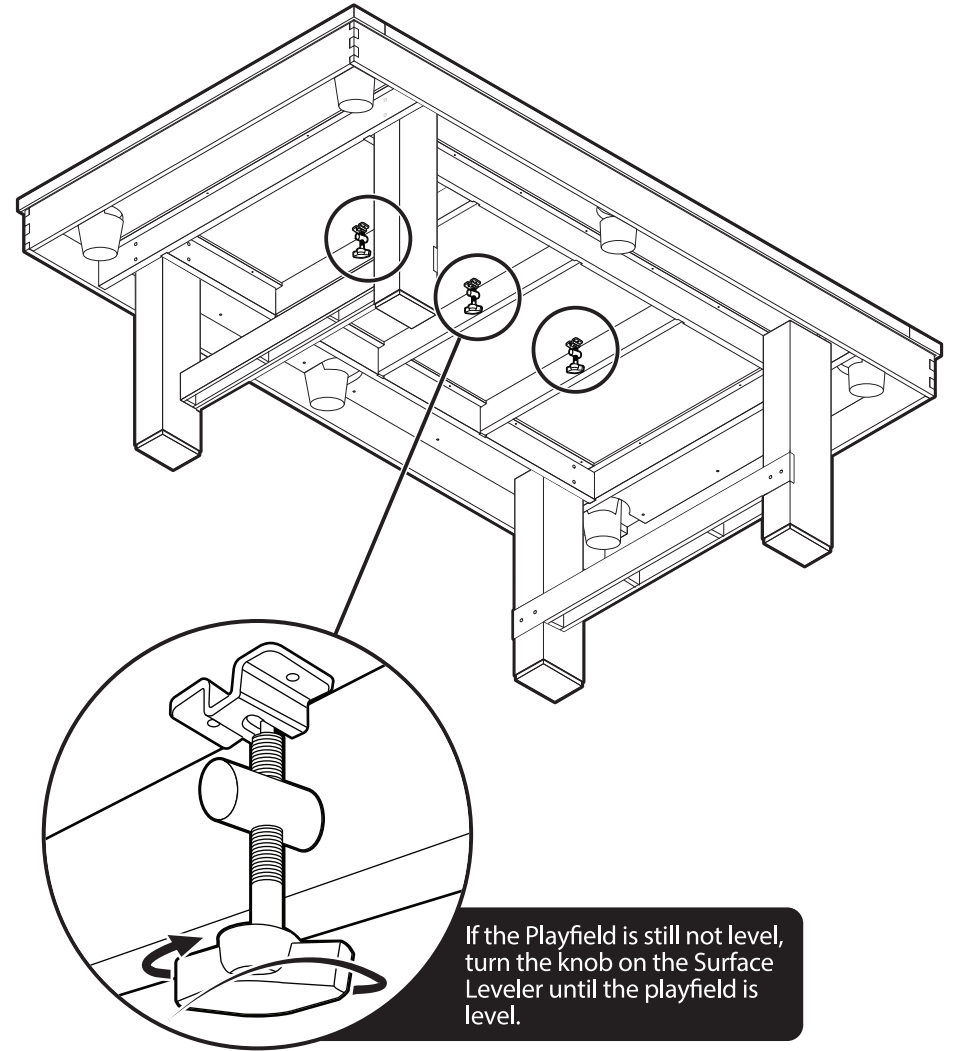

If the Playfield is still not level, turn the knob on the Surface Leveler until the playfield is level.

7

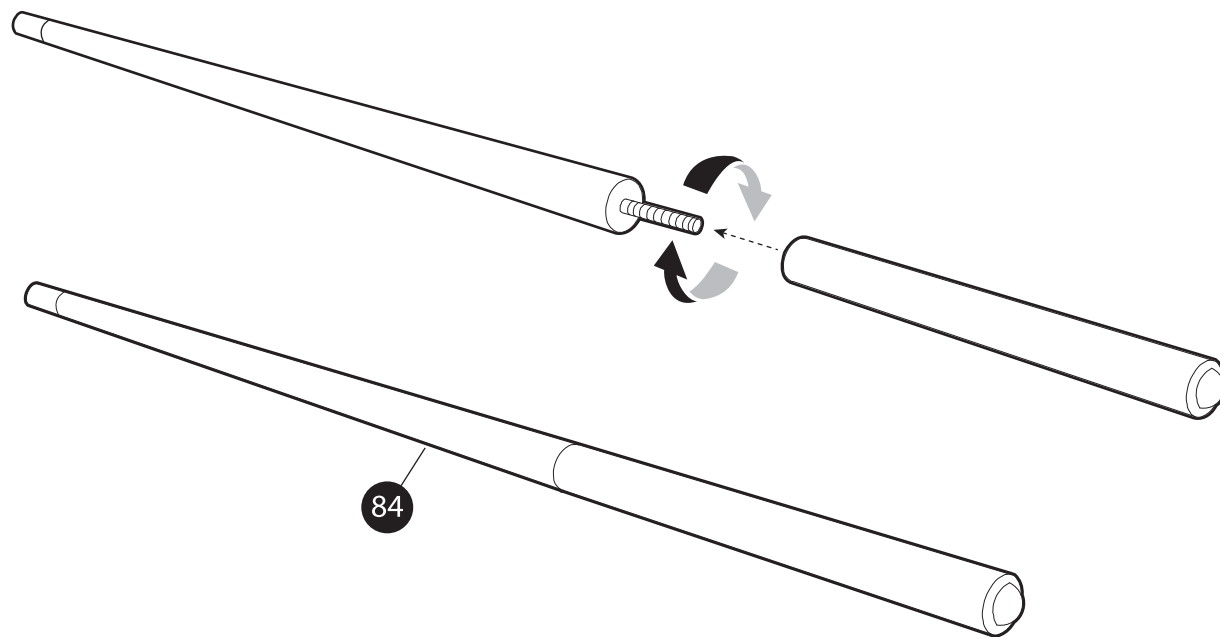

LIMITED WARRANTY

As described in and as limited by this Limited Warranty, EastPoint Sports Ltd., LLC (the "Company") warrants this Product to be free from defects in workmanship and materials for a period of 90 days from the date of original purchase. The term defects shall mean any imperfections that impair the use of the product. The Company reserves the right to request confirmation of Proof of Purchase when requesting parts or service in order to confirm that this Product is within its warranty period and terms.

What is Covered: Except as provided herein, this Limited Warranty covers all defects in materials and workmanship. This Limited Warranty is void if the Product is:

- Damaged through improper usage or storage, negligence, misuse, abuse, transportation damage, acts of nature, or accident (including failure to follow the instructions supplied with the product).
- Used in commercial applications, rentals or a commercial environment.
- Modified or repaired by anyone not authorized by the Company.

What is Not Covered:

The Limited Warranty does not cover:

- Expendable items such as cosmetic parts, game playing accessories, and any other items that may show signs of wear due to normal usage.
- Any transportation/delivery/installation costs incurred by the Consumer (either home from the original place of purchase or back to the original place of purchase).
- Items not purchased from an authorized retailer (ie: this warranty does not apply to so-called "grey market" goods (those goods purchased from a third party)).

What the Company Will Pay For:

- If any part or component of the Product which is covered by this Limited Warranty is found by the Company to be defective, the Company will provide replacement parts without charge. The Company's obligation to repair or replace the Product or any portion of thereof, shall be limited to the original purchase price of the product.
- If during the Limited Warranty period, the product is found to be defective, the Company will, at the Company's option, repair, replace or make remuneration for the Product (either the same or equivalent value) without charge.

How to Obtain Warranty Service: In order to enforce your rights under this Limited Warranty, you must follow these procedures:

- You must return the ORIGINAL COPY OF YOUR SALES RECEIPT to the Company showing a purchase from an authorized retailer.
- You must call the Company's Consumer Service Department at 1-973-585-4747 on Monday through Friday between the hours of 9:00 A.M. and 5:00 P.M. (EST) to notify the Company of the nature of the problem. At the Company's option, replacement parts or a new Product (either the same or equivalent value) will be sent to you at no charge.
- If you are instructed to return the Product to the Company for servicing, you are responsible for shipping the Product, at your expense, to the address designated by the Company in packaging that will protect against further damage.
- You must also include your name, address, daytime telephone number, Product model number, and a description of the problem.
- The Company will pay for any shipping charges to return the repaired or replaced Product to you.

THIS LIMITED WARRANTY IS AVAILABLE ONLY TO THE ORIGINAL PURCHASER OF THE PRODUCT, PURCHASING FROM AN AUTHORIZED RETAILER, AND IS VALID ONLY IN THE UNITED STATES AND CANADA.

THE COMPANY'S LIABILITY IS LIMITED TO THE REPAIR, REPLACEMENT, OR REMUNERATION, AT ITS OPTION, OF ANY DEFECTIVE PRODUCT AND SHALL NOT INCLUDE ANY LIABILITY FOR INDIRECT, INCIDENTAL, OR CONSEQUENTIAL DAMAGES OF ANY KIND. THIS WARRANTY IS EXPRESSLY MADE IN LIEU OF ALL OTHER WARRANTIES, EXPRESSED OR IMPLIED, INCLUDING BUT NOT LIMITED TO THE IMPLIED WARRANTY OF MERCHANTABILITY AND THE IMPLIED WARRANTY OF FITNESS FOR A PARTICULAR PURPOSE. SOME STATES DO NOT ALLOW LIMITATIONS ON HOW LONG AN IMPLIED WARRANTY LASTS OR DO NOT ALLOW FOR EXCLUSION OF INCIDENTAL OR CONSEQUENTIAL DAMAGES. TO THAT EXTENT, THE ABOVE LIMITATIONS MAY NOT APPLY TO YOU.

This Limited Warranty gives you specific legal rights, but you may also have other rights that vary from state to state.

If you have questions regarding this Limited Warranty or the operation of the Product, you may call or write us.

ALL WARRANTY CLAIMS MUST BE ACCOMPANIED BY AN ORIGINAL COPY OF THE SALES RECEIPT/PROOF OF PURCHASE. REPORT ANY DEFECTS TO: EastPoint Sports, 20 Commerce Boulevard, Succasunna, NJ 07876, 1-973-585-4747

PRINTED IN CHINA