

## Professional installation suggested

Assemblage professionnel suggéré

Ensamblaje profesional sugerido

### IMPORTANT: BEFORE BEGINNING THE ASSEMBLY

Make sure to validate the following information:

1. Wall anchor screws are not included. You must contact a professional to determine which screws are required for the studs in your wall. Please refer to step 5.
2. Maximum weight supported: 1000 lbs distributed
3. Maximum mattress thickness: 12"
4. Bed will not stay down without the weight of the mattress.
5. Bed installs on carpet may not open or close properly. Level using the PA-844 (leg levelers) until the bed opens and closes properly.
6. Minimum height of ceiling needed with crown moldings: 93"  
Minimum height of ceiling needed without crown molding: 91"

### IMPORTANT : AVANT DE DÉBUTER L'ASSEMBLAGE

Assurez-vous de valider les informations suivantes :

1. Les vis d'ancrage au mur ne sont pas incluses. Consultez un professionnel pour sélectionner les vis appropriées aux montants dans votre mur. Référez-vous à l'étape 5.
2. Poids maximum supporté : 1000 lbs distribués
3. Épaisseur maximale de matelas : 12"
4. Le lit ne restera pas abaissé sans le poids du matelas.
5. Lorsque installé sur un tapis, le lit peut ne pas ouvrir ou fermer correctement. Nivelier en utilisant les PA-844 (pattes ajustables) jusqu'à ce que le lit ouvre et ferme correctement.
6. Hauteur minimale de plafond nécessaire pour l'installation du lit avec moulures de tête : 93"  
Hauteur minimale de plafond nécessaire pour l'installation du lit sans moulure de tête : 91"

### IMPORTANTE : ANTES DE EMPEZAR EL ENSAMBLAJE

Asegúrese de validar las informaciones siguientes :

1. Los tornillos de anclaje a la pared no son incluidos. Consulte a un profesional para seleccionar los tornillos adaptados a los importes en su pared. Refiérase a la etapa 5.
2. Peso máximo sostenido : 1000 lbs distribuidos
3. Espesor máximo de colchón : 12"
4. La cama no quedará abbaissé sin el peso del colchón.
5. Cuando instalada sobre una alfombra, la cama puede no abrir o cerrarse correctamente. Nivelar utilizando PA-844 (patas ajustables) hasta que la cama abra y se cierre correctamente.
6. Altura mínima de techo necesario para la instalación de la cama con molduras de cabeza : 93 "  
Altura mínima de techo necesario para la instalación de la cama sin moldura de cabez : 91 "

**Thank you for choosing our product.  
Your total satisfaction is our #1 priority.**

Customer Service and warranty information

Should you have a problem or need more information concerning the warranty, **do not call to the place of purchase.**  
**Please call our customer service department for immediate assistance using the following toll free number.**

Please have your assembly instruction manual on hand when you call. Our products are warranted to the original purchaser against defects in material or workmanship in the furniture. Defects as mentioned in this warranty refer to any imperfections which may impair the use of the product. Our warranty is expressly limited to the replacement of furniture parts and components for ten years following the date of purchase. We will replace any part that is defective. This warranty applies under conditions of normal use. Our furniture products are not intended for outdoor use. The warranty does not cover defects caused by improper assembly or disassembly, defects occurring after purchase due to product modifications, intentional damage, accident, misuse, exposure to the elements and labor or assembly costs. We reserve the right to request proof of purchase to document a warranty claim. In no event shall we be liable for incidental or consequent damages resulting from the misuse of the product. This warranty is not transferable and is valid only in Canada and the United States excluding Alaska, Hawaii and Puerto Rico.

**MERCI D'AVOIR CHOISI LES PRODUITS.  
VOUS SATISFAIRE EST NOTRE PRIORITÉ.**







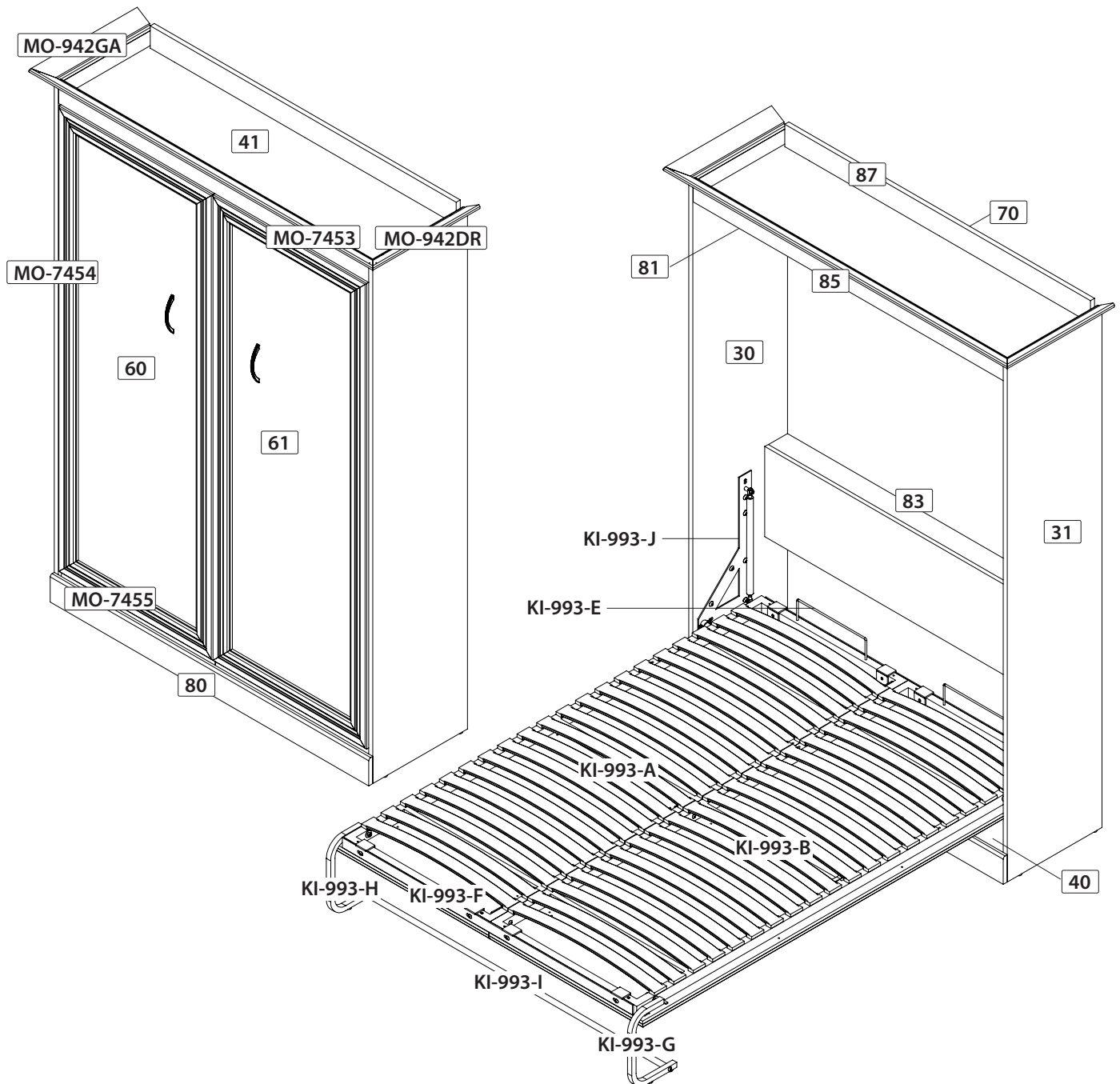





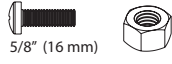
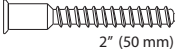



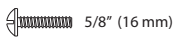

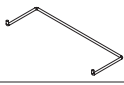
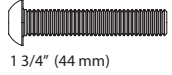



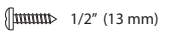
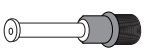

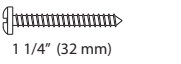

***Gracias por elegir un producto.  
Su entera satisfacción es nuestra prioridad N°1.***

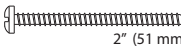
PARTS / PIÈCES / PIEZAS

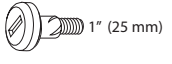
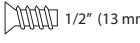
CODE / CÓDIGO	QTY / QTÉ / CANT.	CODE / CÓDIGO	QTY / QTÉ / CANT.	CODE / CÓDIGO	QTY / QTÉ / CANT.	CODE / CÓDIGO	QTY / QTÉ / CANT.
30	1	61	1	85	1	MO-942GA	1
31	1	70	2	87	1	MO-942DR	1
40	1	80	1	MO-7453	1	40822	1
41	1	81	1	MO-7454	4		
60	1	83	1	MO-7455	4		

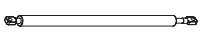

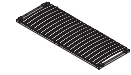
HARDWARES / QUINCAILLERIES / QUINCALLAS

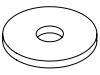
CODE / CÓDIGO	QTY / QTÉ / CANT.	CODE / CÓDIGO	QTY / QTÉ / CANT.	CODE / CÓDIGO	QTY / QTÉ / CANT.	CODE / CÓDIGO	QTY / QTÉ / CANT.
CA-100 	16	KI-993-C 	1	KI-993-L 	4	VC-204 	16
EQ-980 	3	KI-993-D 	1	KI-993-M 	12	VF-230 	4
GO-796 	21	KI-993-E 	2	KI-993-N 	8	VG-206 	32
H-03 	8	KI-993-F 	2	KI-993-O 	3	VR-207 	4
H-36 	8	KI-993-G 	1	KI-993-P 	2	VR-213 	5
KI-932H 	16	KI-993-H 	1	KI-993-Q 	1	VR-215 	8
KI-932I 	16	KI-993-I 	1	PA-844 	4	3500-400350 	24
KI-993-A 	1	KI-993-J 	2	PO-912 	2	EQ-943 	2
KI-993-B 	1	KI-993-K 	12	RO-994 	4	LEG WARNING STICKER ÉTIQUETTE AVERTISSEMENT DE LA PATTE ETIQUETA DE ADVERTENCIA DE LA PIERNA	1

REAL SIZE / GRANDEUR RÉELLE / TAMAÑO REAL

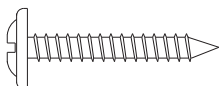
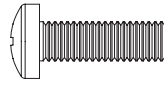
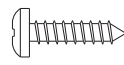
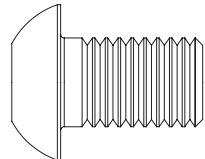
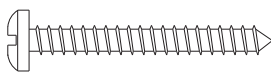
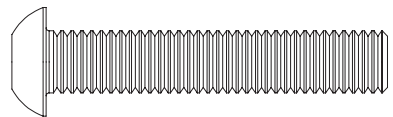
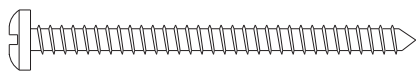
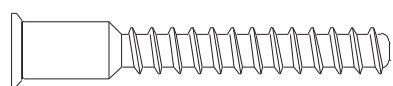
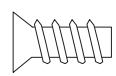
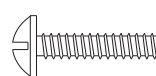
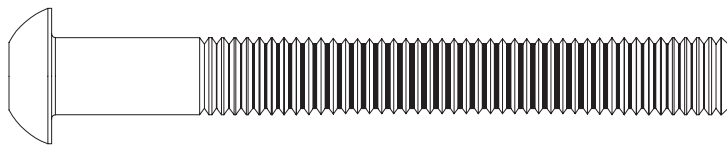
CODE / CÓDIGO	QTY / QTÉ / CANT.	CODE / CÓDIGO	QTY / QTÉ / CANT.
KI-932I  5/8" (16 mm)	16	VG-206  1" (25 mm)	32
KI-993-L  5/8" (16 mm)	4	VR-207  1/2" (13 mm)	4
KI-993-M  5/8" (16 mm)	12	VR-213  1 1/4" (32 mm)	5
KI-993-N  1 3/4" (44 mm)	8	VR-215  2" (51 mm)	8
VC-204  2" (50 mm)	16	3500-400350  1/2" (13 mm)	24
VF-230  5/8" (16 mm)	4		
KI-993-O  2 3/4" (70 mm)			3

**Professional installation suggested**

Assemblage professionnel suggéré

Ensamblaje profesional sugerido

**IMPORTANT: BEFORE BEGINNING THE ASSEMBLY**

Make sure to validate the following information:

1. Wall anchor screws are not included. You must contact a professional to determine which screws are required for the studs in your wall. Please refer to step 5.
2. Maximum weight supported: 1000 lbs distributed
3. Maximum mattress thickness: 12"
4. Bed will not stay down without the weight of the mattress.
5. Bed install on carpet may not open or close properly. Level using the PA-844 (leg levelers) until the bed opens and closes properly.
6. Minimum height of ceiling needed with crown molding: 93"  
Minimum height of ceiling needed without crown molding: 91"

**IMPORTANT : AVANT DE DÉBUTER L'ASSEMBLAGE**

Assurez-vous de valider les informations suivantes :

1. Les vis d'ancrage au mur ne sont pas incluses. Consultez un professionnel pour sélectionner les vis appropriées aux montants dans votre mur. Référez-vous à l'étape 5.
2. Poids maximum supporté : 1000 lbs distribués
3. Épaisseur maximale de matelas : 12"
4. Le lit ne restera pas abaissé sans le poids du matelas.
5. Lorsque installé sur un tapis, le lit peut ne pas ouvrir ou fermer correctement. Nivelier en utilisant les PA-844 (pattes ajustables) jusqu'à ce que le lit ouvre et ferme correctement.
6. Hauteur minimale de plafond nécessaire pour l'installation du lit avec moulures de tête : 93"  
Hauteur minimale de plafond nécessaire pour l'installation du lit sans moulure de tête : 91"

**IMPORTANTE : ANTES DE EMPEZAR EL ENSAMBLAJE**

Asegúrese de validar las informaciones siguientes :

1. Los tornillos de anclaje al pared no son incluidos. Consulte a un profesional para seleccionar los tornillos adaptados a los muros en su pared. Refiérase a la etapa 5.
2. Peso máximo soportado: 1000 lbs distribuidos
3. Espesor máximo de colchón: 12"
4. La cama no quedará abajada sin el peso del colchón.
5. Cuando instalado sobre una alfombra, la cama puede no abrir o cerrarse correctamente. Nivelar utilizando PA-844 (patas ajustables) hasta que la cama abra y se cierre correctamente.
6. Altura mínima de techo necesario para la instalación de la cama con molduras de cabeza: 93"  
Altura mínima de techo necesario para la instalación de la cama sin molduras de cabeza: 91"

For future reference and to better serve you, please complete and apply the self-adhesive sticker in an accessible space such as the back side of part 61.

Pour mieux vous servir en cas de besoin, veuillez compléter et apposer l'autocollant dans un endroit facilement accessible tel que sur l'endos de la pièce 61.

Para futura referencia y mejor servicio por favor pegue la etiqueta en un lugar accesible, por ejemplo el fondo de la pieza 61.

**IMPORTANT NOTICE / NOTE IMPORTANTE / NOTA IMPORTANTE**

► **Main hardware system. Installation steps / Système de quincaillerie principal. Étapes d'installation.**  
*Sistema principal de quincalla. Etapas de instalación.*

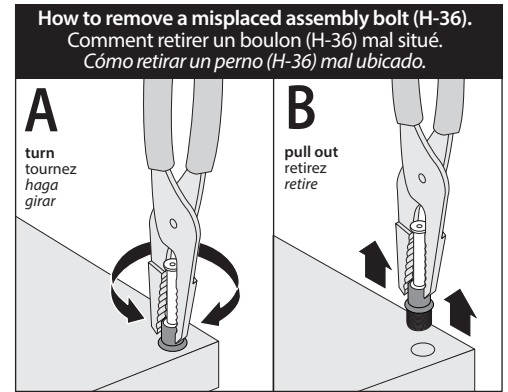
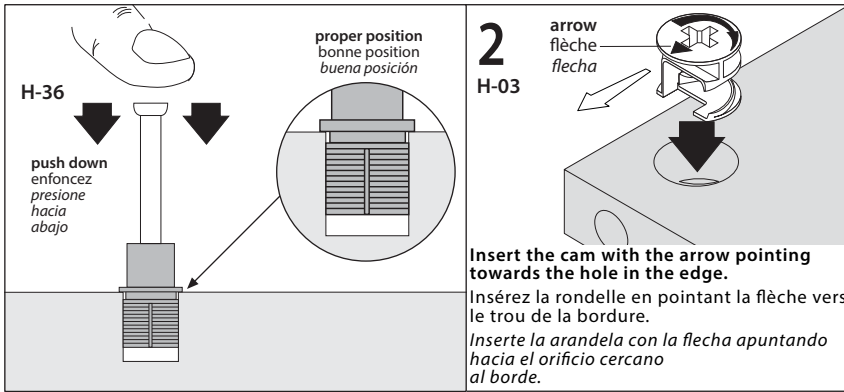

► **Main hardware system. Assembly steps / Système de quincaillerie principal. Étapes d'assemblage.**  
*Sistema principal de quincalla. Etapas de ensamblaje.*

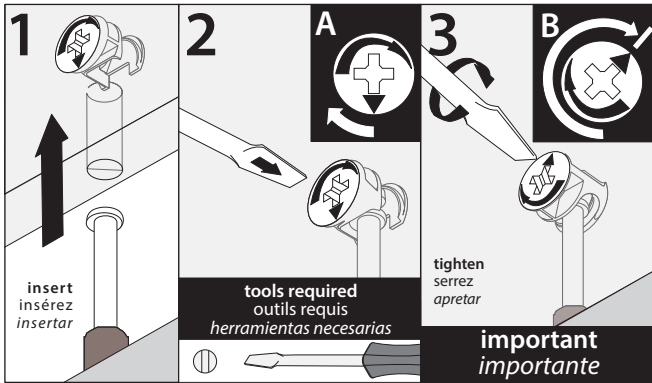

**Make sure to properly tighten each cam to ensure furniture solidity. Otherwise, parts could be damaged or the user could be injured.**

Assurez-vous de bien resserrer chaque rondelle pour assurer la solidité du meuble. Dans le cas contraire, des pièces pourraient être endommagées ou l'utilisateur pourrait se blesser.

Asegúrese de apretar bien cada arandela para garantizar la solidez del mueble. De lo contrario, podría provocarse daño a las piezas o las personas.

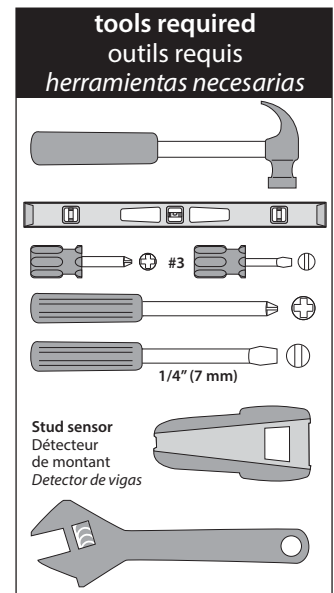

**Assembling sequence**  
 Séquence d'assemblage  
 Secuencia de ensamblaje  
**Parts / Pièces / Piezas:**

41 + EQ-980 + 87 81

**IMPORTANT / IMPORTANTE**

Place boxes under parts during the assemblies to avoid damages.  
 Placer les boîtes sous les pièces lors des assemblages pour éviter les bris.  
 Colocar las cajas bajo las piezas en el momento de los ensamblajes para evitar los quebrantos.

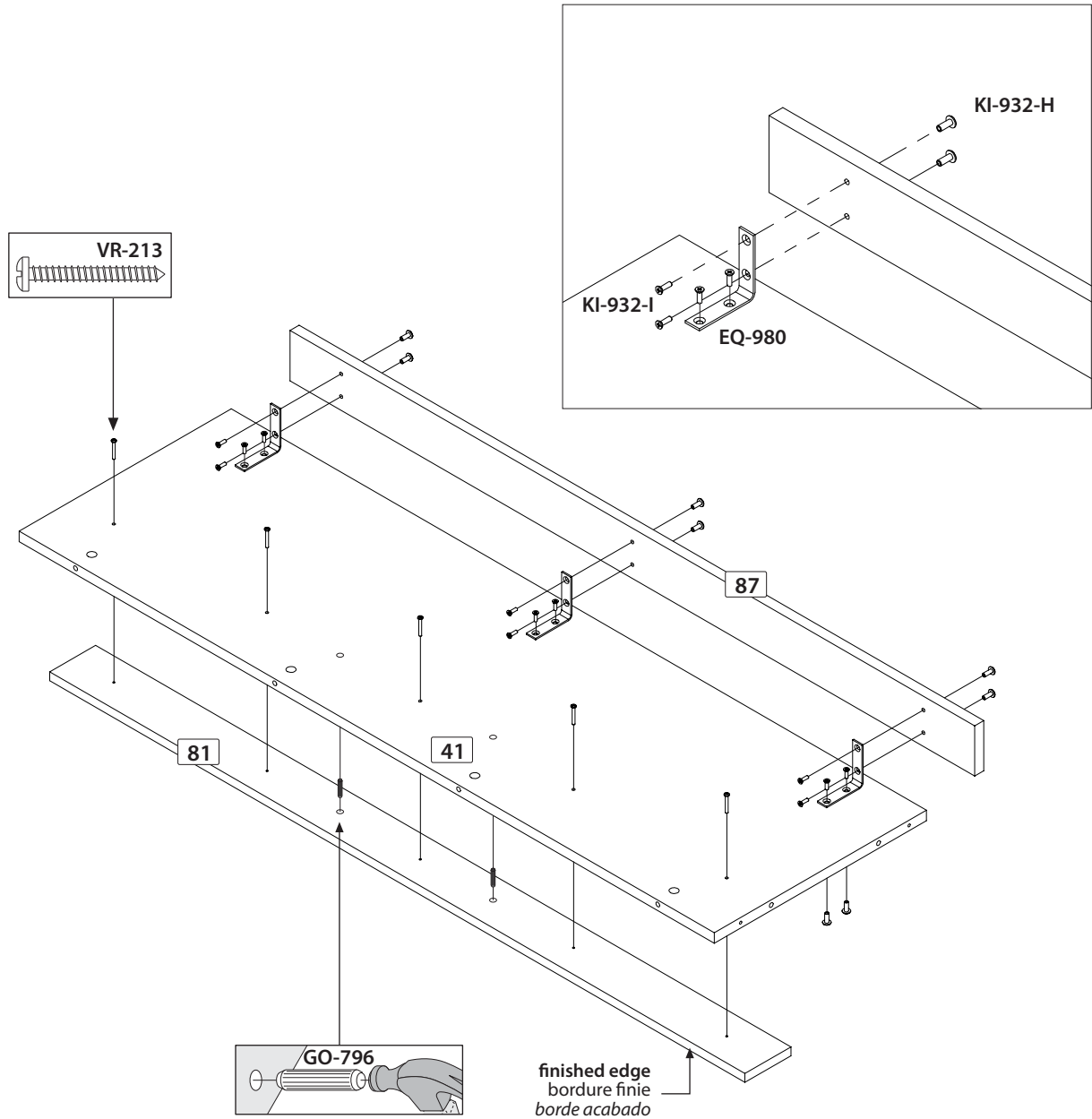

Code / Código	EQ-980	KI-932H	KI-932I	VR-213	GO-796
Qty / Qté / Cant.	x 3	x 12	x 12	x 5	x 2

**Assembling sequence**  
 Séquence d'assemblage  
 Secuencia de ensamblaje  
**Parts / Pièces / Piezas:**



**30** + KI-993-D + KI-993-M

**31** + KI-993-C + KI-993-M

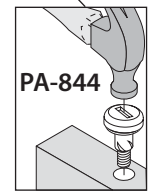
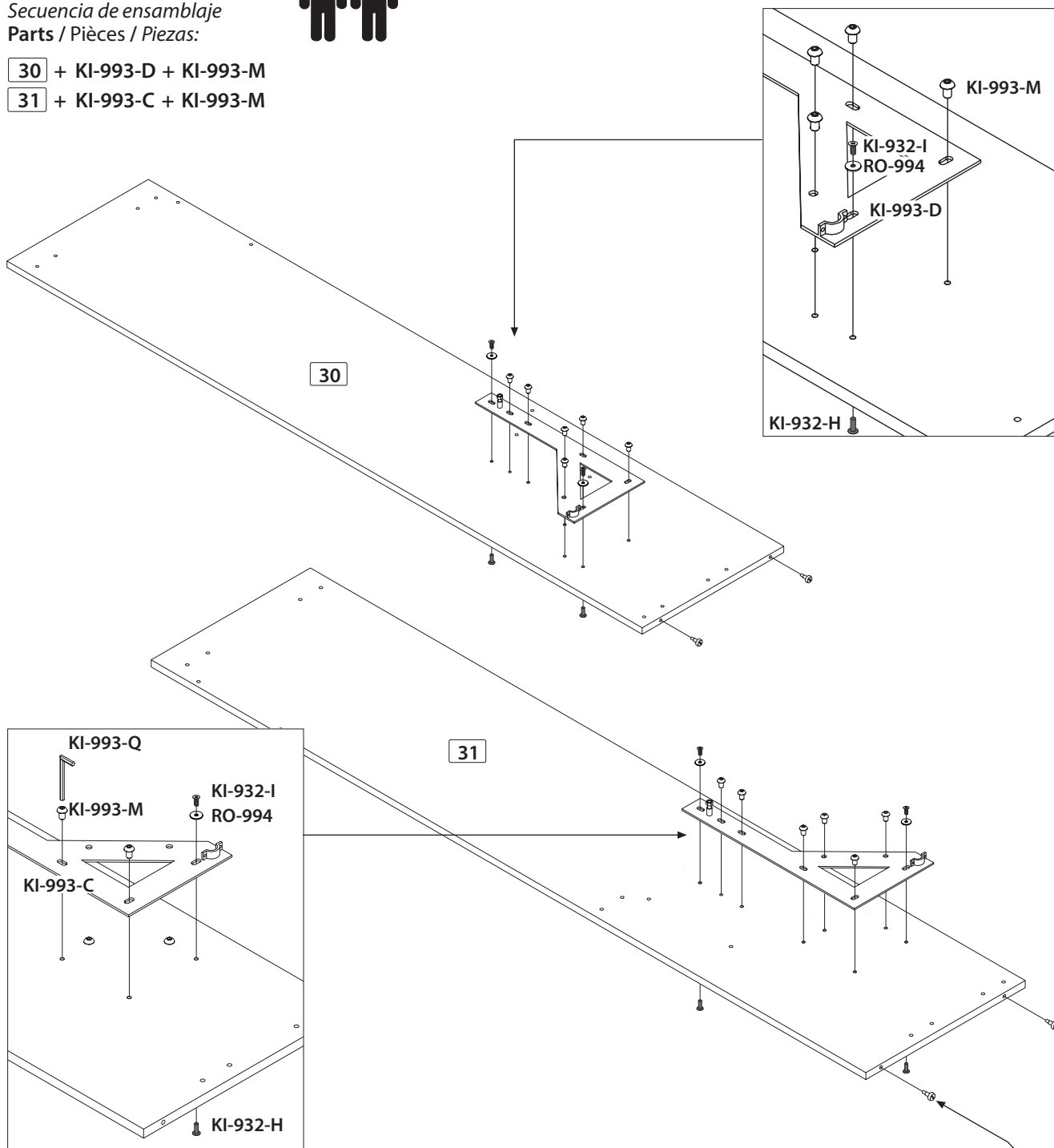

<b>Code / Código</b>	KI-993-C	KI-993-D	KI-993-M	KI-993-Q	PA-844	RO-994	KI-932I	KI-932H
<b>Qty / Qté / Cant.</b>	x 1	x 1	x 12	x 1	x 4	x 4	x 4	x 4

**Assembling sequence**  
 Séquence d'assemblage  
 Secuencia de ensamblaje  
 Parts / Pièces / Piezas:



70 83 30 31 41 40

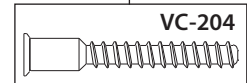
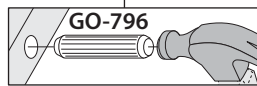
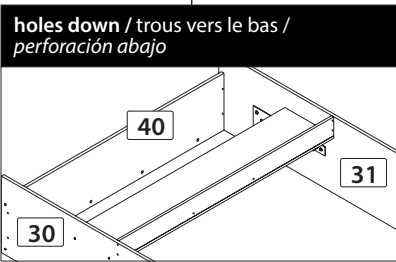
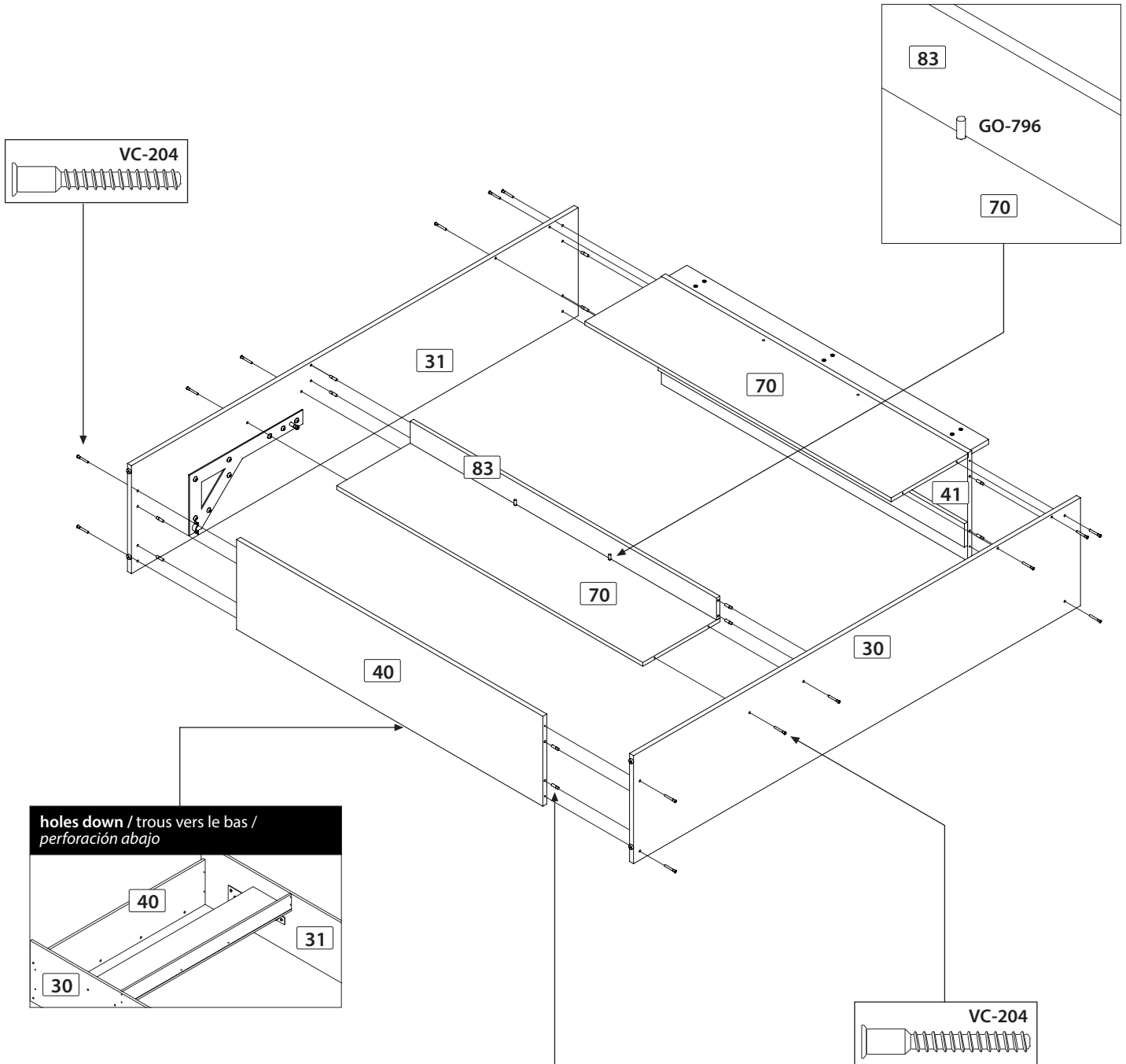

Code / Código	GO-796	VC-204
Qty / Qté / Cant.	x 14	x 16



**You can be seriously injured if you don't follow these instructions**

**Vous risquez d'être gravement blessé si vous ne suivez pas ces instructions**

**Usted corre peligro de ser herido gravemente si usted no sigue estas instrucciones**

## IMPORTANT: CONTACT A PROFESSIONAL

**THE UNIT HAS TO LEAN ON ALL ITS LENGTH ON THE WALL OF THE ROOM.**

Follow these steps:

1. Determine where your bed will be located.
2. Level the unit. To level your furniture, adjust leg PA-844 (installed previously in step 2)
3. Find the location of the studs in the wall by using a stud sensor, then identify the area (anchor zone) which will align with the stud.
4. Wall anchor screws are not included. You must contact a professional to determine which screws are required for the studs in your wall. Please refer to step 5.
5. Refer to the identified anchor zones to screw into the plywood board (part 87) to fix to the wall. Use the appropriate screws for your studs. **THE SCREWS MUST BE VERY WELL ANCHORED INTO STUDS.**

## IMPORTANT : CONSULTER UN PROFESSIONNEL

**LE MEUBLE DOIT S'APPUYER SUR TOUTE SA LONGUEUR AU MUR DE LA PIÈCE.**

Pour son installation, veuillez suivre les étapes suivantes :

1. Connaître l'emplacement final de votre lit vertical.
2. Nivelier. Pour nivelier le meuble, ajuster les pattes PA-844 (installées préalablement à l'étape 2)
3. Trouver l'emplacement des montants dans votre mur à l'aide d'un détecteur de montant, identifier ensuite la section (zone d'ancrage) qui s'alignera avec le montant.
4. Les vis d'ancrage au mur ne sont pas incluses. Consultez un professionnel pour sélectionner les vis appropriées aux montants dans votre mur. Référez-vous à l'étape 5.
5. Visser dans les zones d'ancrage identifiées à travers la bande de contre-plaqué (pièce 87) pour la fixation au mur. Utiliser des vis appropriées aux montants de votre mur. **LES VIS DOIVENT ÊTRE TRÈS BIEN ANCRÉES DANS LES MONTANTS.**

## IMPORTANTE: CONSULTAR A UN PROFESIONAL

**EL MUEBLE DEBE APOYARSE EN TODA SU LONGITUD A la MADURA DE LA PIEZA.**

Siga las etapas siguientes para su instalación con la pared :

1. Situar la unidad en su emplazamiento final.
2. Nivelar. Para nivelar su mueble, ajustar la pata PA-844 (Instaladas previamente a la etapa 2)
3. Encontrar el emplazamiento de los importes en su pared con un detector de importes, identificar luego la sección (zona de anclaje) que se alineará con importe.
4. Los tornillos de anclaje a la pared no son incluidos. Consulte a un profesional para seleccionar los tornillos adaptados a los importes en su pared. Refiérase a la etapa 5.
5. Antornillar en las zonas de anclaje identificadas a través de la banda de contrachapado (pieza 87) para la fijación a la pared. Utilizar tornillos adaptados a los importes de su pared. **LOS TORNILLOS DEBEN SER MUY BIEN ANCLADOS IN LOS IMPORTES.**

**This manufacturer is released from any responsibility if bed is not secured to the wall into wood or metal studs.**

**Ce fabricant se dégage de toutes responsabilités si le lit n'est pas fixé au mur dans les montants en bois ou en métal.**

**Este fabricante se libran de toda responsabilidad si la cama no es fijada sobre la pared en importes de madera o en metal.**



ANCHOR ZONES / ZONES D'ANCRAGE / ZONAS DE ANCLAJE

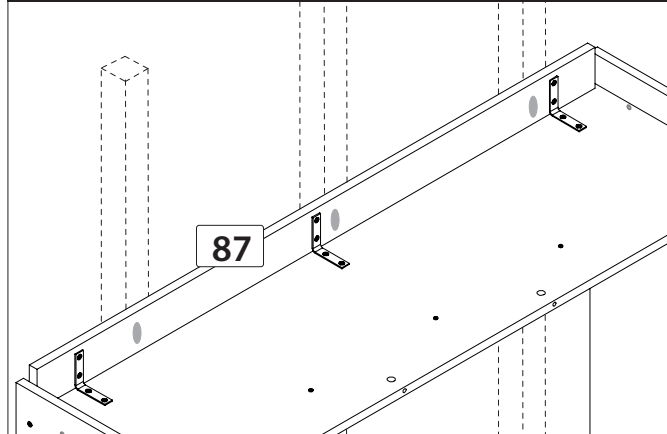

STUDS / MONTANTS / IMPORTES

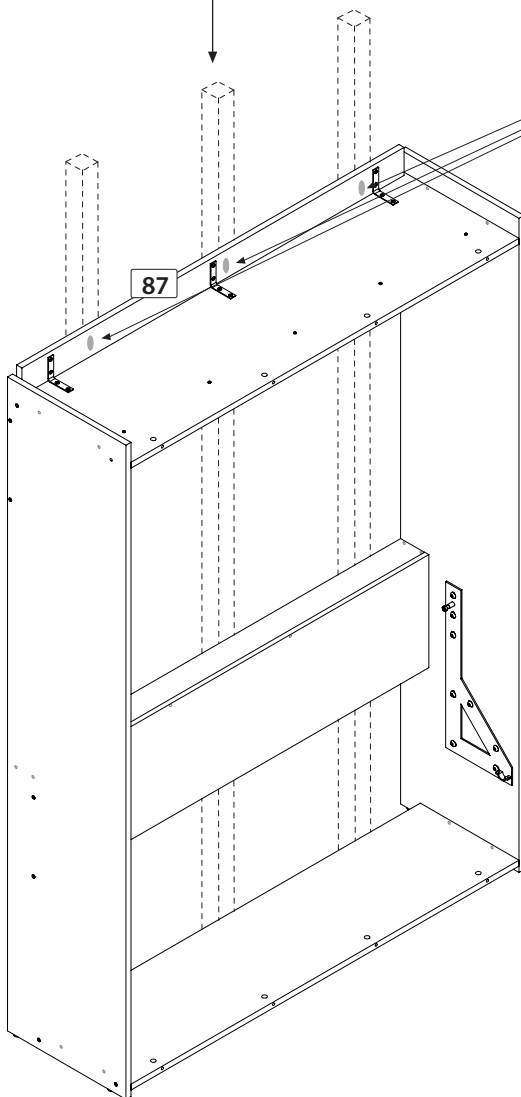



**Assembling sequence**  
 Séquence d'assemblage  
 Secuencia de ensamblaje  
**Parts / Pièces / Piezas:**

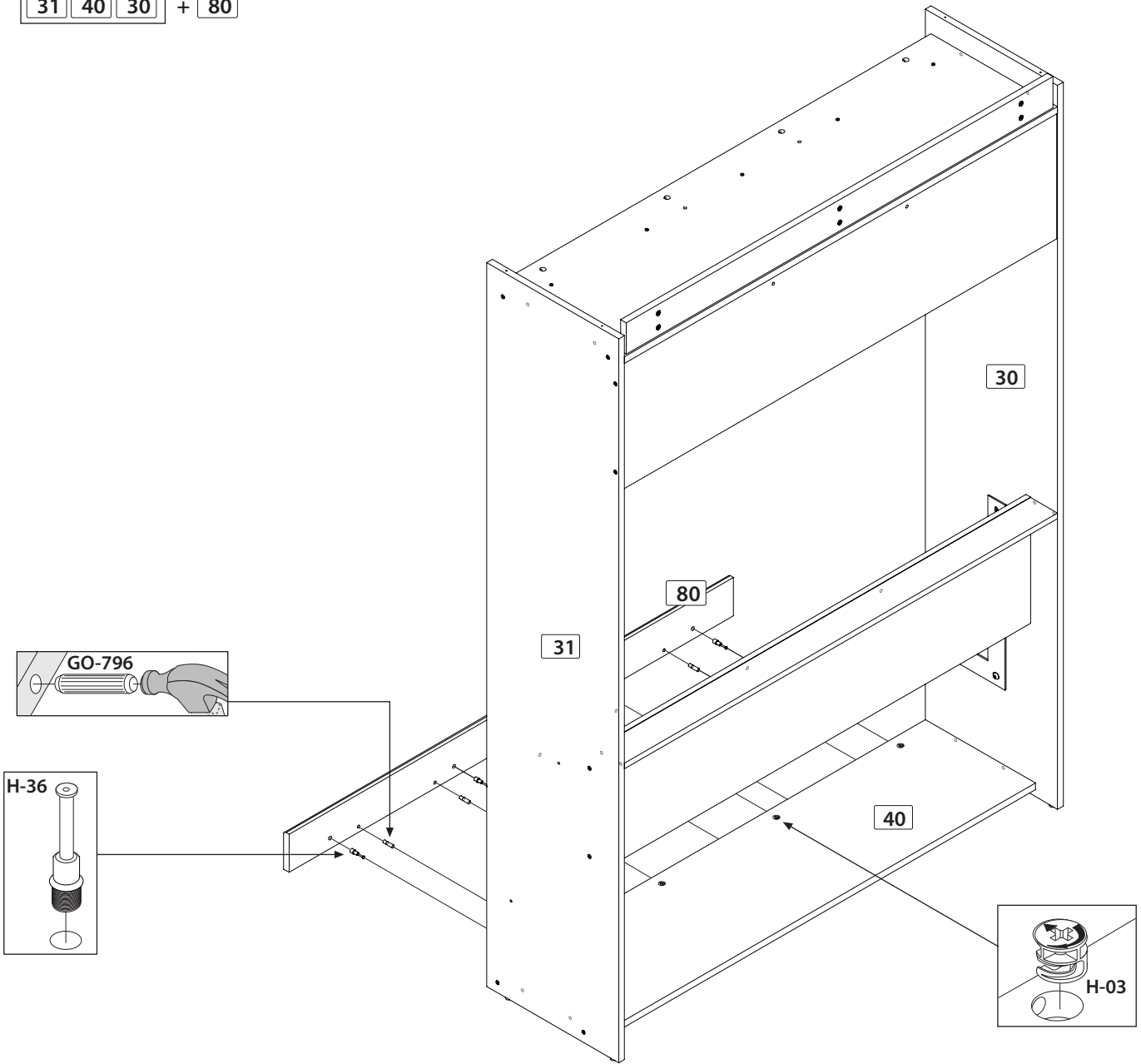

31 40 30 + 80

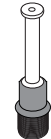

			
Code / Código	GO-796	H-03	H-36
Qty / Qté / Cant.	x 5	x 4	x 4

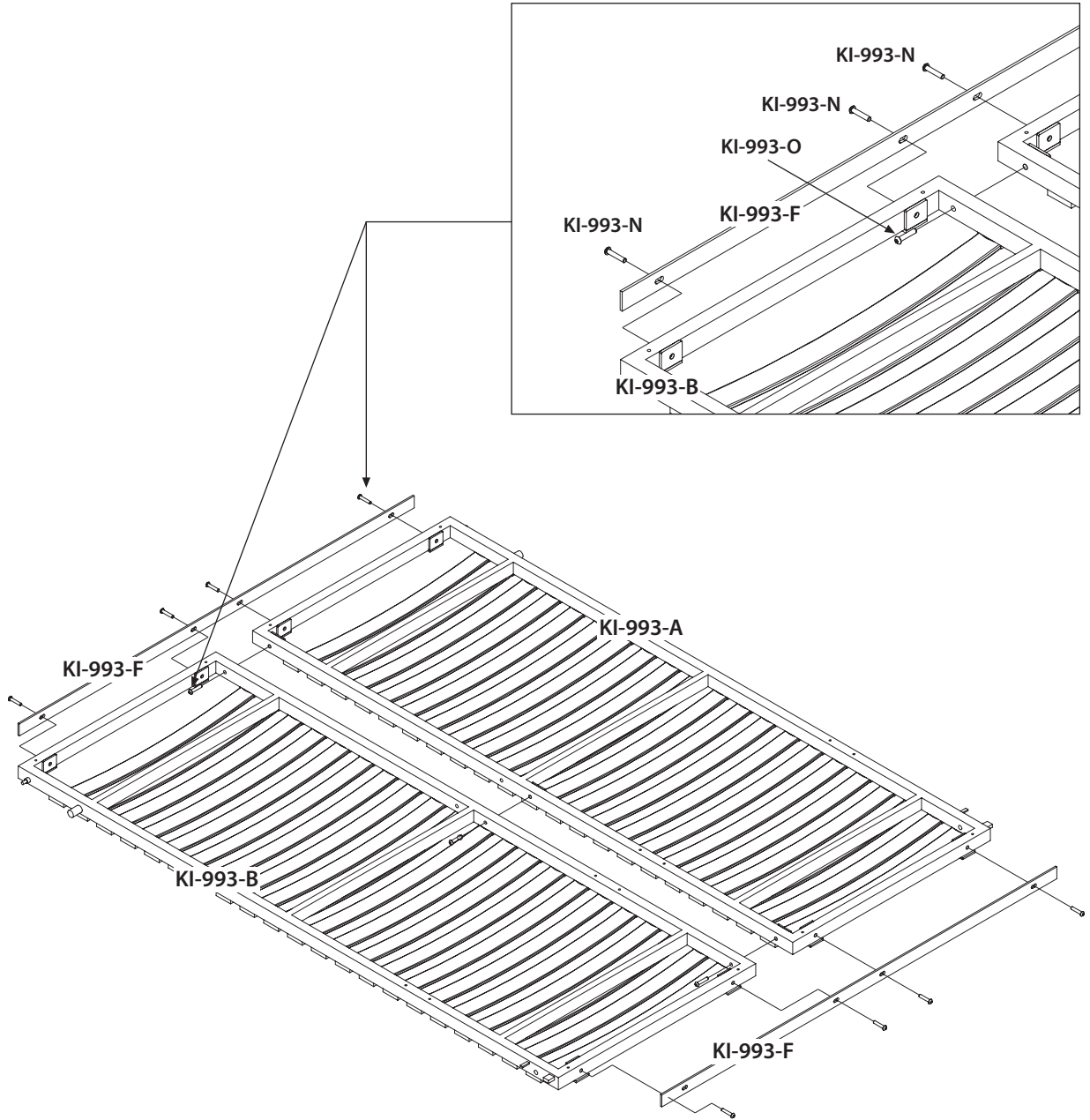

Code / Código	KI-993-A	KI-993-B	KI-993-F	KI-993-N	KI-993-O
Qty / Qté / Cant.	x 1	x 1	x 2	x 8	x 3

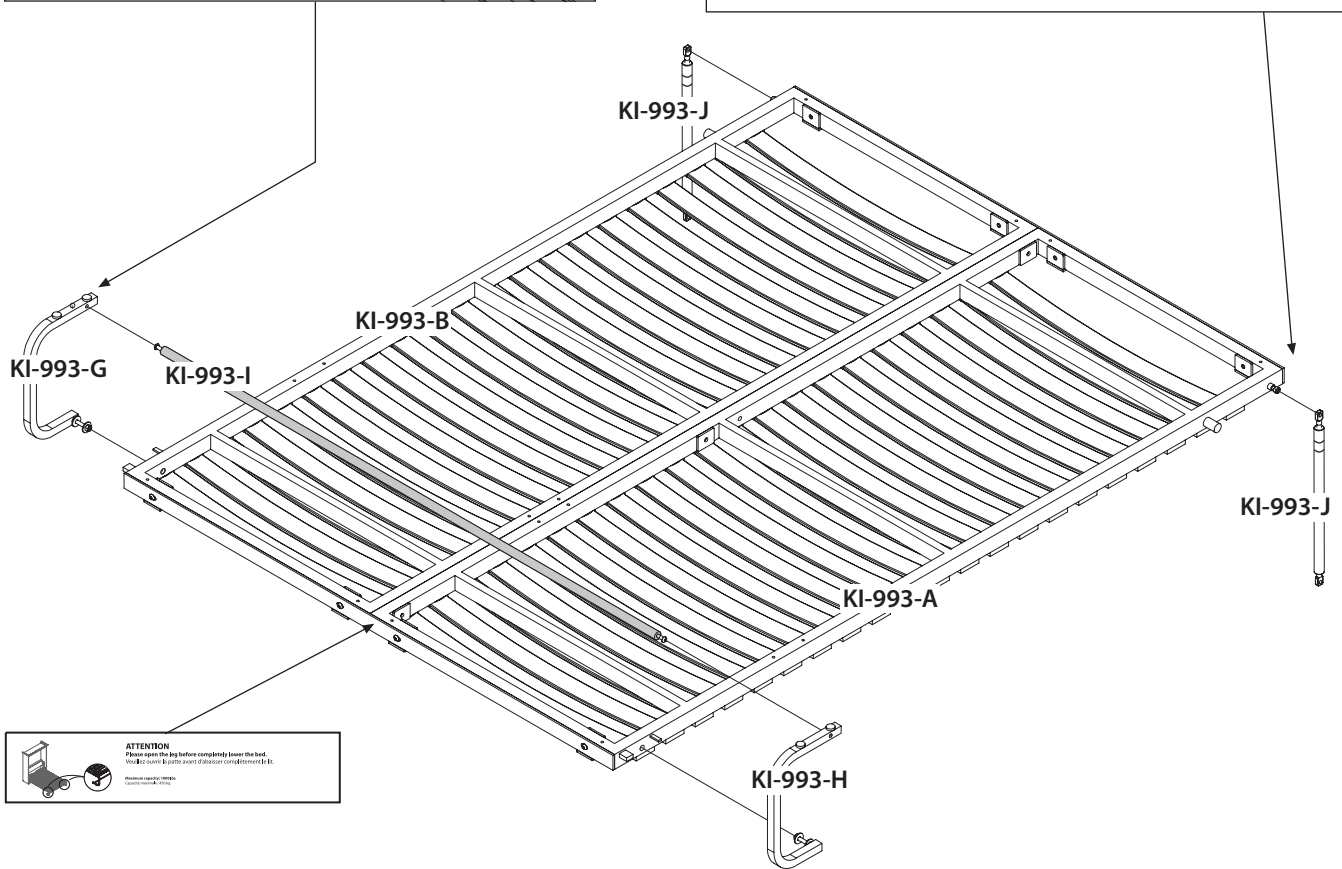
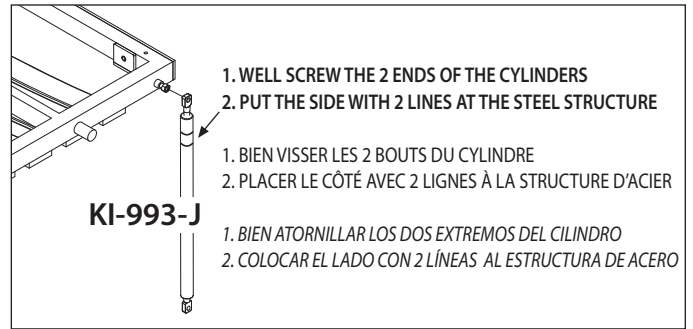
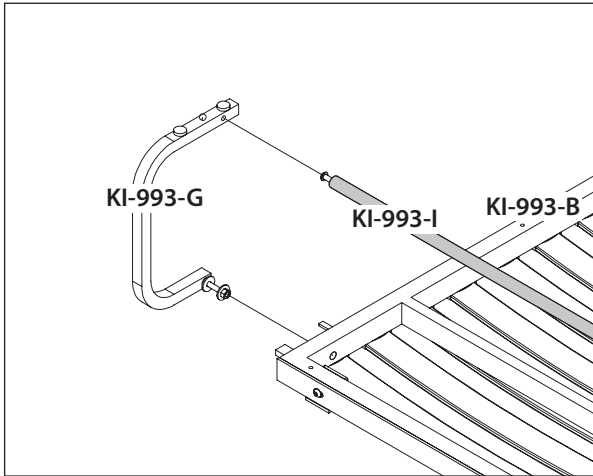

**ATTENTION**  
Please open the bag before completely leave the bed.  
No se debe abrir la bolsa hasta haber desmontado el lecho.  
Atención: Abrir el paquete antes de desmontar el lecho.

Code / Código	KI-993-G	KI-993-H	KI-993-I	KI-993-J
Qty / Qté / Cant.	x 1	x 1	x 1	x 2



### Important/Importante

PUT THE SIDE WITH 2 LINES AT THE STEEL STRUCTURE  
 PLACER LE CÔTÉ AVEC 2 LIGNES À LA STRUCTURE D'ACIER  
 COLOCAR EL LADO CON 2 LÍNEAS AL ESTRUCTURA DE ACERO

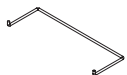
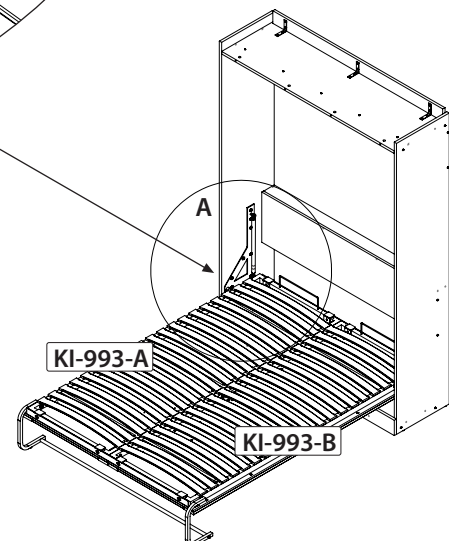
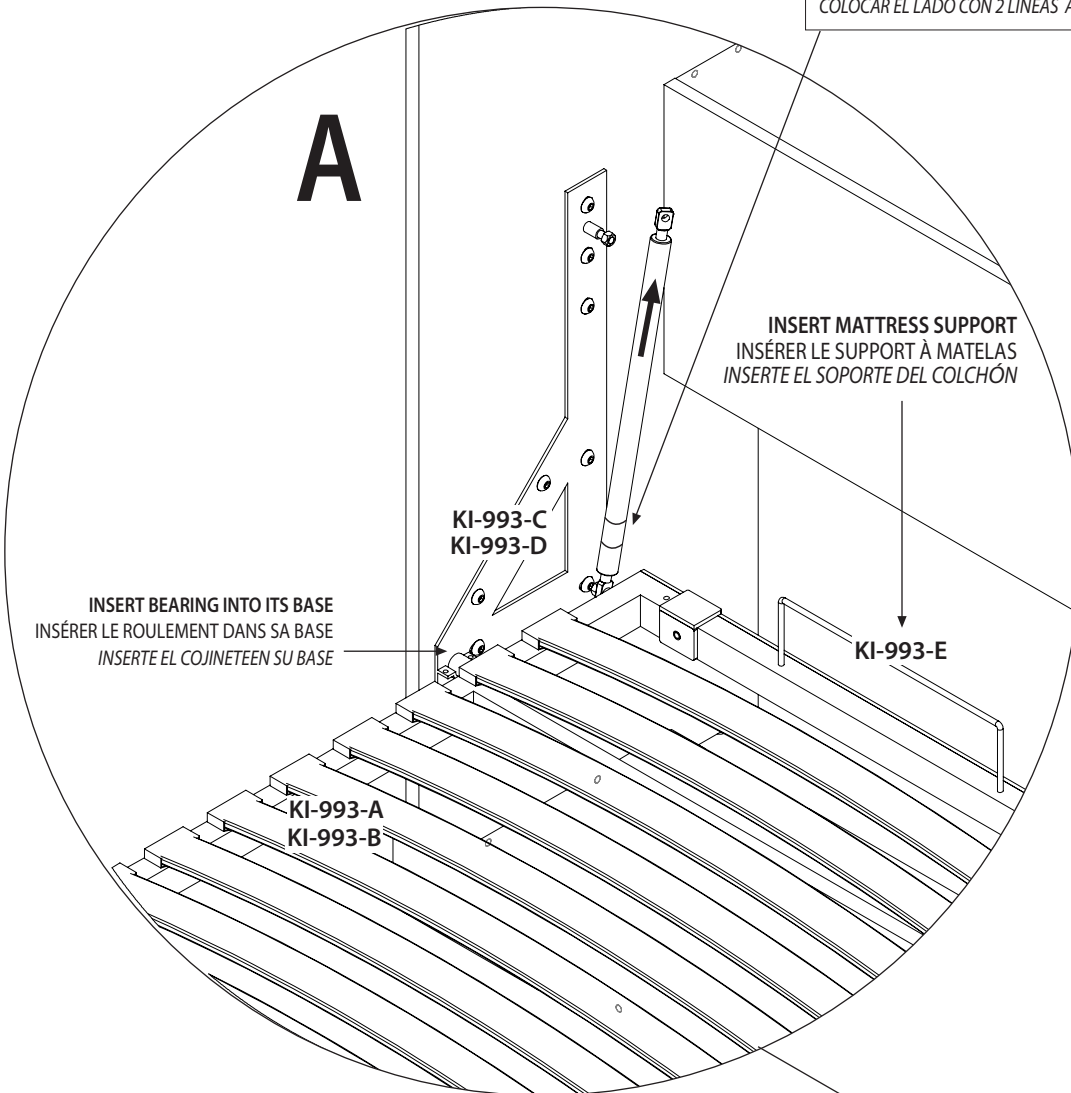

Code / Código

KI-993-E

Qty / Qté / Cant.

x 2



### Important/Importante

1. Place the bearings equal on each side before fixing them up.
  2. Tighten strongly the bearing support.
1. Positionner les roulements égaux de chaque côté avant de les fixer en place.
2. Serrer fortement le support de roulement.
1. Coloque los rodamientos iguales a cada lado antes de fijar para arriba.
2. Apriete firmemente el soporte de rodamiento.

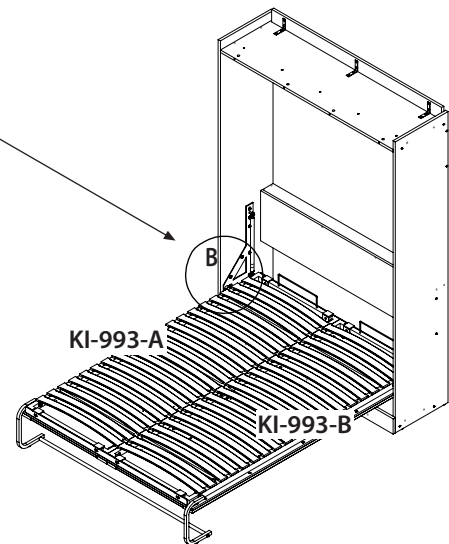
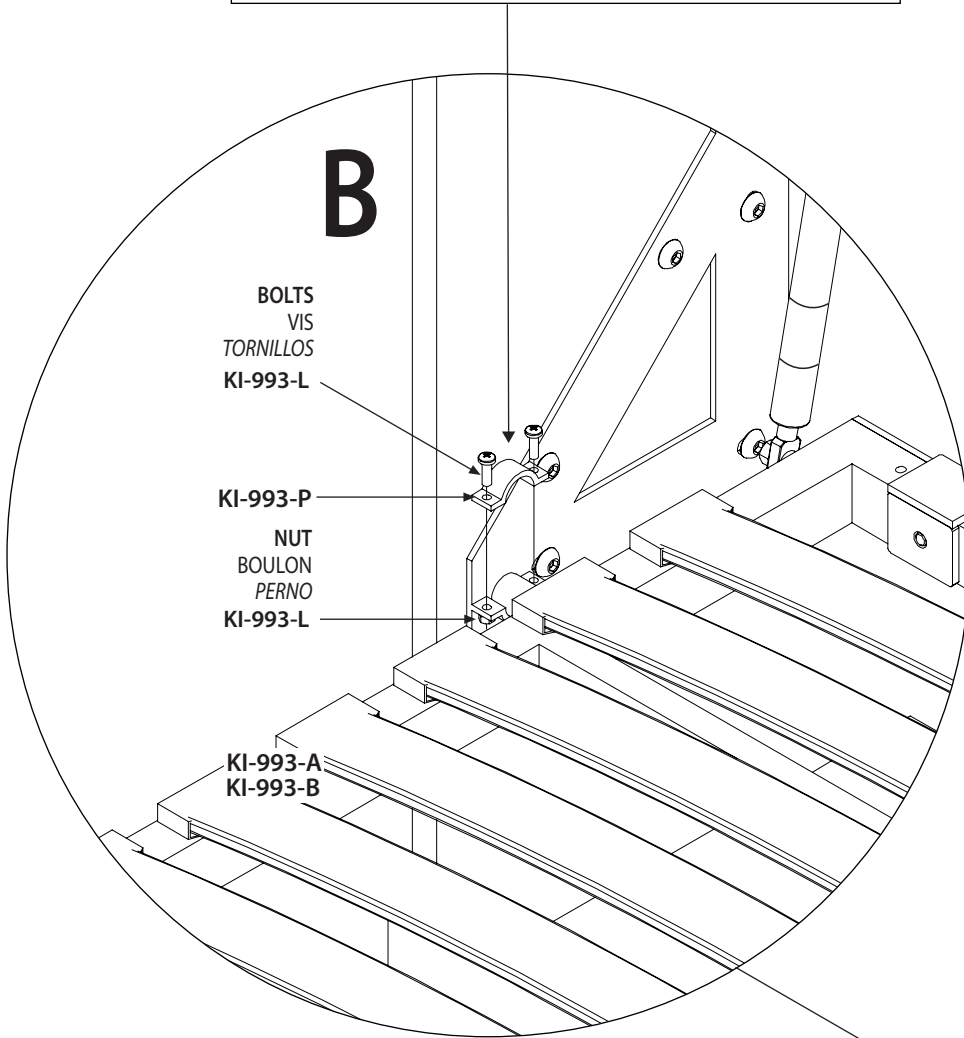

5/8" (16 mm)



Code / Código

KI-993-L

KI-993-P

Qty / Qté / Cant.

x 4

x 2

**Important/Importante**

At this stage, the pistons are closed and locked for your safety.

À cette étape, les pistons sont fermés et barrés pour votre sécurité.

En esta etapa, los pistones están cerrados y cruzados para su seguridad.

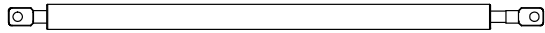

INSERT CYLINDER ON ITS STEM / INSÉRER LE CYLINDRE SUR SA TIGE  
INSERTE EL CILINDRO EN SU TALLO

KI-993 must be completely tightened  
KI-993 doit être complètement serré  
KI-993 debe ser completamente apretado

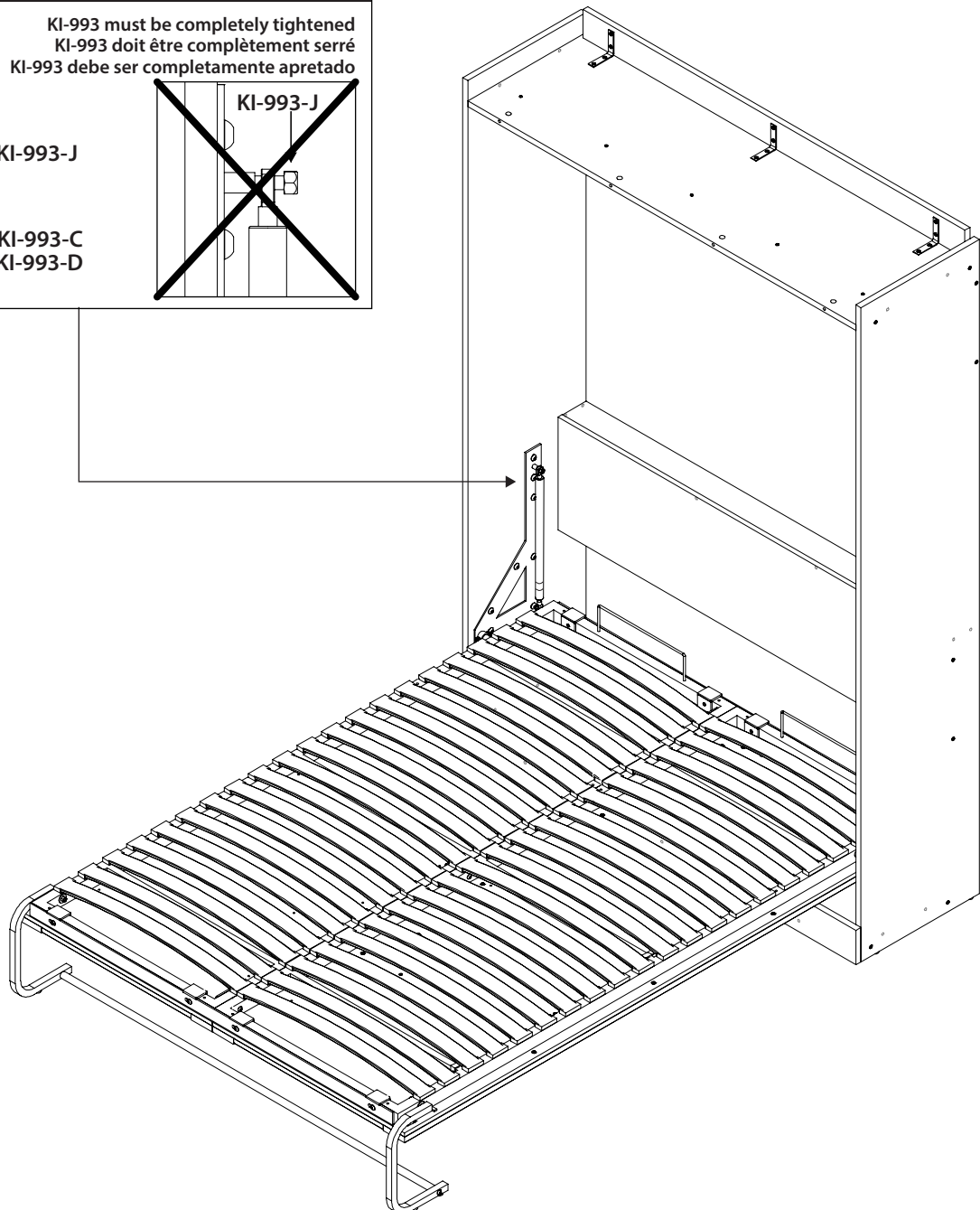
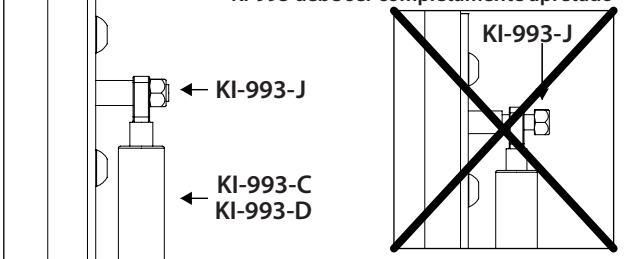

## Important/Importante

### Functioning of the cylinder

The cylinder, originally, is closed and locked.  
To be usable, the cylinder must be unlocked.

### Fonctionnement du cylindre

Le cylindre, à l'origine, est fermé et verrouillé..  
Pour que le cylindre fonctionne il doit être déverrouillé.

### Funcionamiento del cilindro

El cilindro de origen es cerrado y encerrado..  
Para que el cilindro funcione debe ser quitado el cierre.

Original cylinder  
Cylindre à l'origine  
El cilindro de origen

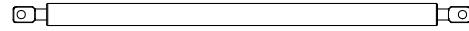

Unlocked cylinder  
Cylindre déverrouillé.  
Cilindro quitado el cierre.

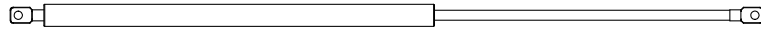

## TO UNLOCK THE CYLINDER POUR DÉVERROUILLER LE CYLINDRE PARA QUITAR EL CIERRE EL CILINDRADO

1. Rotate the leg towards the interior.
2. Push down the steel structure until it reaches the floor by pressing the center of the bed as shown below to unlock the 2 cylinders.
3. Close the bed.
4. The cylinders remain locked?

1. Faire pivoter la patte vers l'intérieur.
2. Abaisser la structure d'acier jusqu'au sol en appuyant au centre du lit tel qu'illustré ci-bas afin de débarrer les 2 cylindres.
3. Fermer le lit.
4. Les cylindres demeurent verrouillés?

1. Gire la pata para el interior.
2. Empuje hacia abajo la estructura de acero de hasta el suelo presionando el centro de la cama, como se muestra a continuación para desbloquear los 2 cilindros.
3. Cierre la cama.
4. ¿Los cilindros permanecen bloqueados?

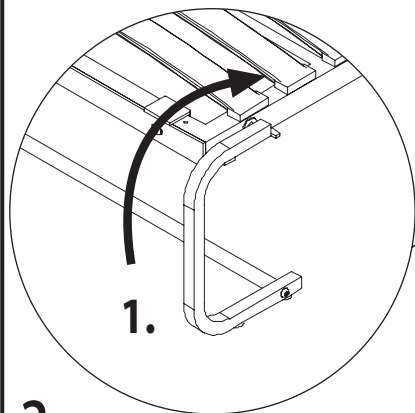
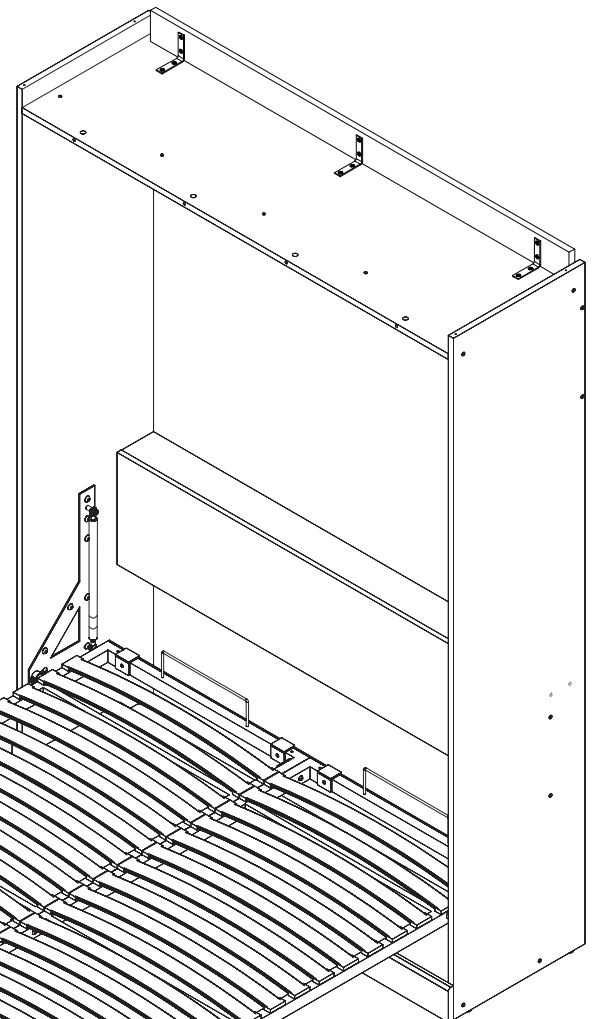

1.



DON'T FORCE UPWARD  
NE PAS FORCER VERS LE HAUT  
NO FORZAR HACIA ARRIBA

2.

PUSH DOWN IN THE CENTER OF THE STRUCTURE UNTIL IT REACHES THE FLOOR  
ABAISSEZ AU CENTRE DE LA STRUCTURE JUSQU'AU SOL  
EMPUJE HACIA ABAJO EN EL CENTRO DE LA ESTRUCTURA DE HASTA EL SUELO



Never force the closure of the bed! Major risk of damages.

Ne jamais forcer la fermeture du lit! Risque de bris majeur.

Nunca fuerce el cierre de la cama! Mayor riesgo de ruptura.

## THE BED DOESN'T CLOSE!

1. Perhaps one piston is locked, then locate the unlocked piston. (rod moves under slight movement of the bed base)
2. Insert a support (~ 6 inches) under the bed base, at the foot of the bed, on the side that the piston still locked.
3. Lower the other corner of the footboard toward the floor, of the opposite side for locking it.  
(At this point, the two pistons must be blocked)
4. Apply the Start-up

### Instruction

- \* Start-up: unlock by push down in the center of the structure until it reaches the floor.
- \* Always put the leg under the structure during the utilisation of the bed, to prevent the pistons to lock each time.

## LE LIT NE FERME PAS!

1. Peut-être qu'un seul piston est verrouillé, alors repérer le piston déverrouillé (tige bouge sous mouvement léger du sommier)
2. Insérer un appui (~ 6 po) sous le sommier au pied du lit du côté du piston encore verrouillé.
3. Abaisser l'autre coin du pied de lit au sol du côté opposé afin de verrouiller celui-ci.  
(À ce moment les 2 pistons doivent être verrouillés)
4. Appliquer l'étape de départ

### Instruction

- \* Étape de départ : déverrouiller en appuyant au centre de la structure jusqu'au sol.
- \* Toujours mettre la patte pour utiliser le lit, afin d'empêcher les pistons de se verrouiller à chaque fois.

## ¡LA CAMA NO SE CIERRA!

1. Quizá uno de pistón está bloqueado, entonces localizar el pistón desbloqueado. (barra se mueve bajo el leve movimiento del somier)
2. Inserte un soporte (~ 6 pulgadas) por debajo de somier, en el pie de la cama, en el lado del pistón todavía bloqueado.
3. Bajar la otra esquina del pie de la cama hacia el suelo del lado opuesto, con el fin de encerrar.  
(En ese momento, los dos pistones deben ser bloqueadas)
4. Aplicar la etapa inicial

### Instrucción

- \* Etapa inicial: desbloquear presionando el centro de la tierra.
- \* Siempre utilice la pata para poner la cama, para evitar que los pistones para bloquear cada vez.

### Important/Importante

Use one of the cardboard corner pieces from packaging or similar object to keep the bed in semi-closed position for facades installation.

Utilisez une des pièces de carton en coin de l'emballage ou un objet similaire afin de maintenir le lit en position semi-fermé pour l'installation des façades.

Utilice una de las piezas de las esquinas de cartón de embalaje o un objeto similar para mantener la cama en posición semi-cerrado para la instalación de fachadas.

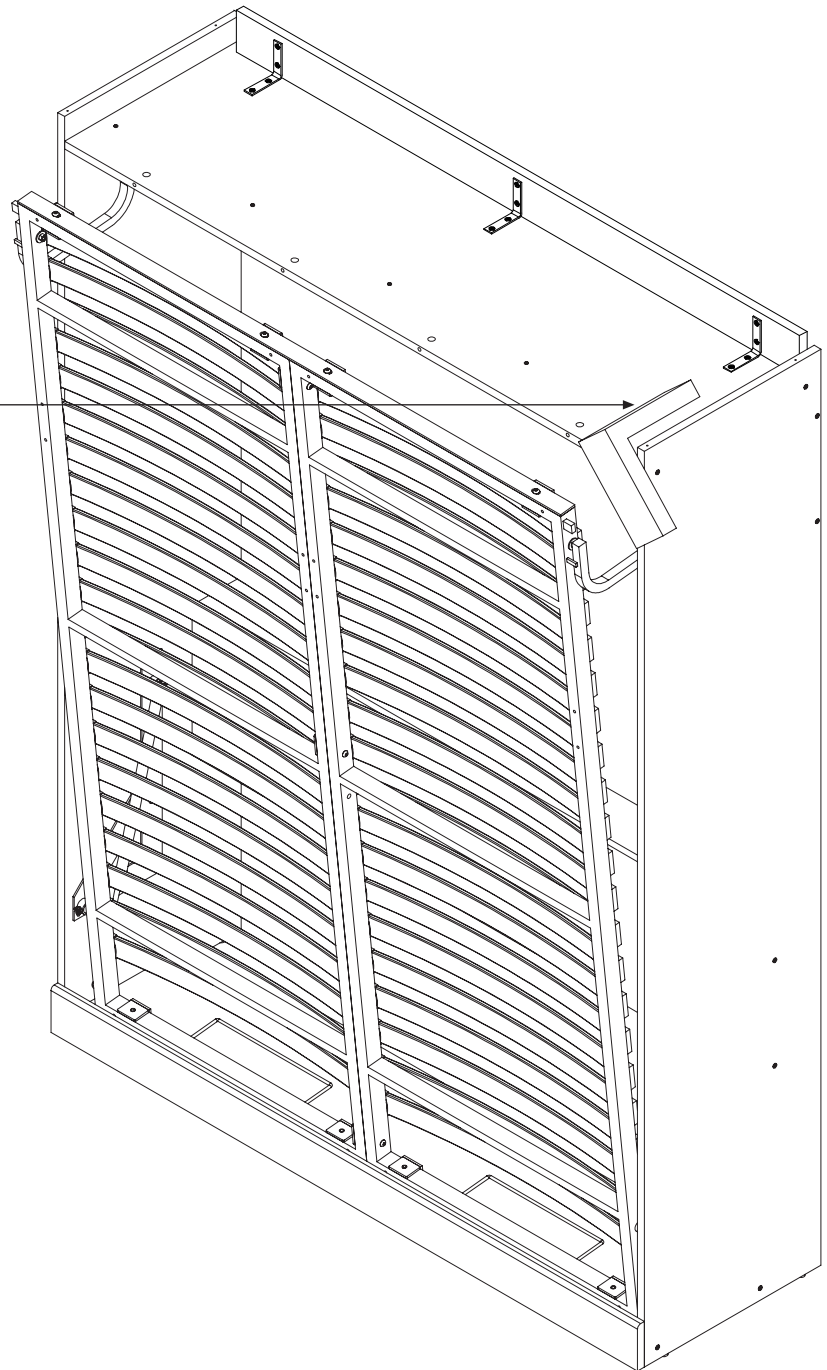

**Assembling sequence**  
 Séquence d'assemblage  
 Secuencia de ensamblaje  
**Parts / Pièces / Piezas:**



**MO-7454 MO-7455** + **61**

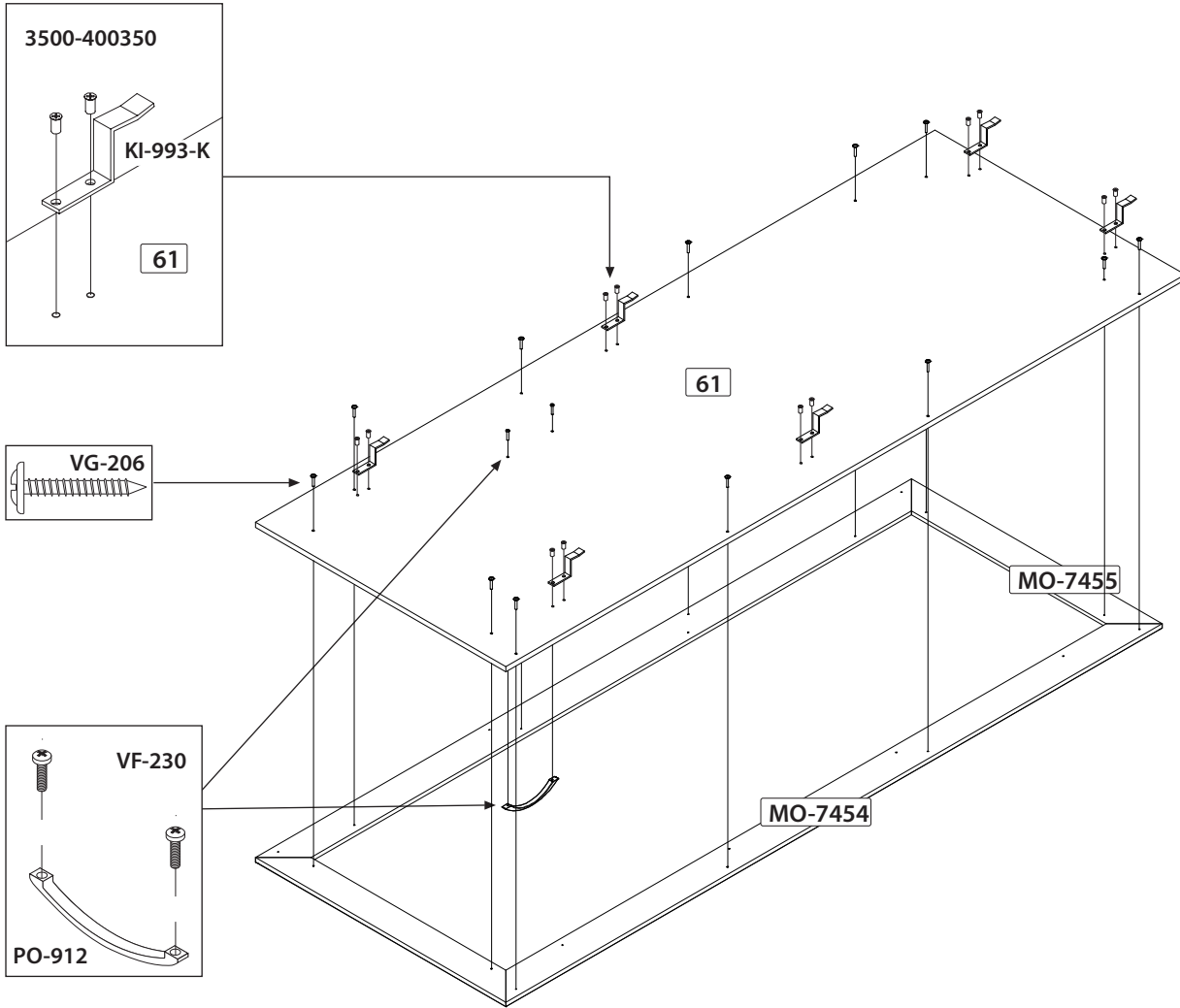

**13**

<b>Code / Código</b>	KI-993-K	PO-912	VF-230 5/8" (16 mm)	VG-206 1" (25 mm)	3500-400350 1/2" (13 mm)
<b>Qty / Qté / Cant.</b>	x 6	x 1	x 2	x 12	x 12

**Assembling sequence**  
 Séquence d'assemblage  
 Secuencia de ensamblaje  
**Parts / Pièces / Piezas:**



MO-7454 MO-7455 + 60

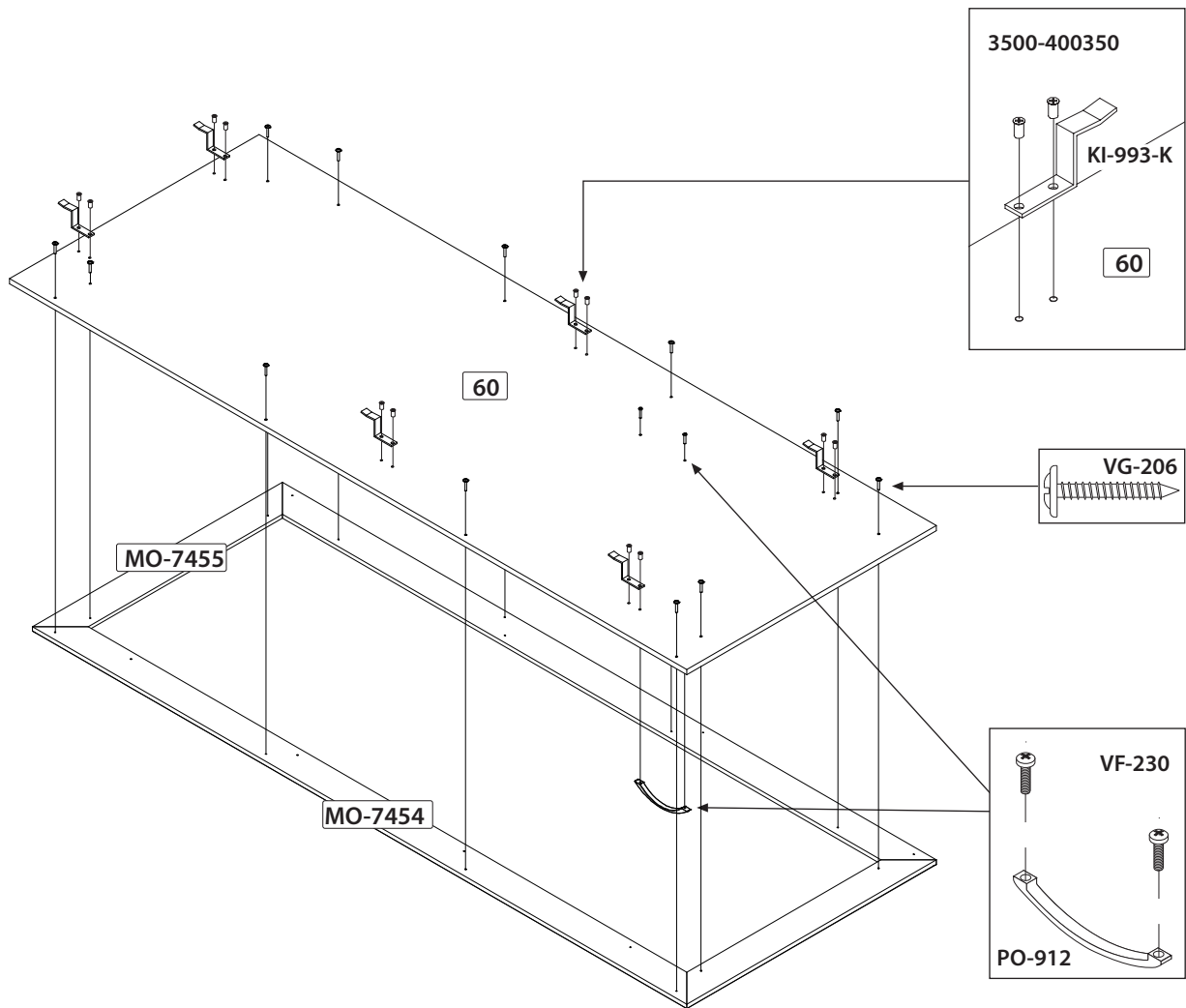

<b>Code / Código</b>	KI-993-K	PO-912	VF-230 5/8" (16 mm)	VG-206 1" (25 mm)	3500-400350 1/2" (13 mm)
<b>Qty / Qté / Cant.</b>	x 6	x 1	x 2	x 12	x 12

**Assembling sequence**  
Séquence d'assemblage  
Secuencia de ensamblaje  
Parts / Pièces / Piezas:



KI-993-A KI-993-B + 60 + 61

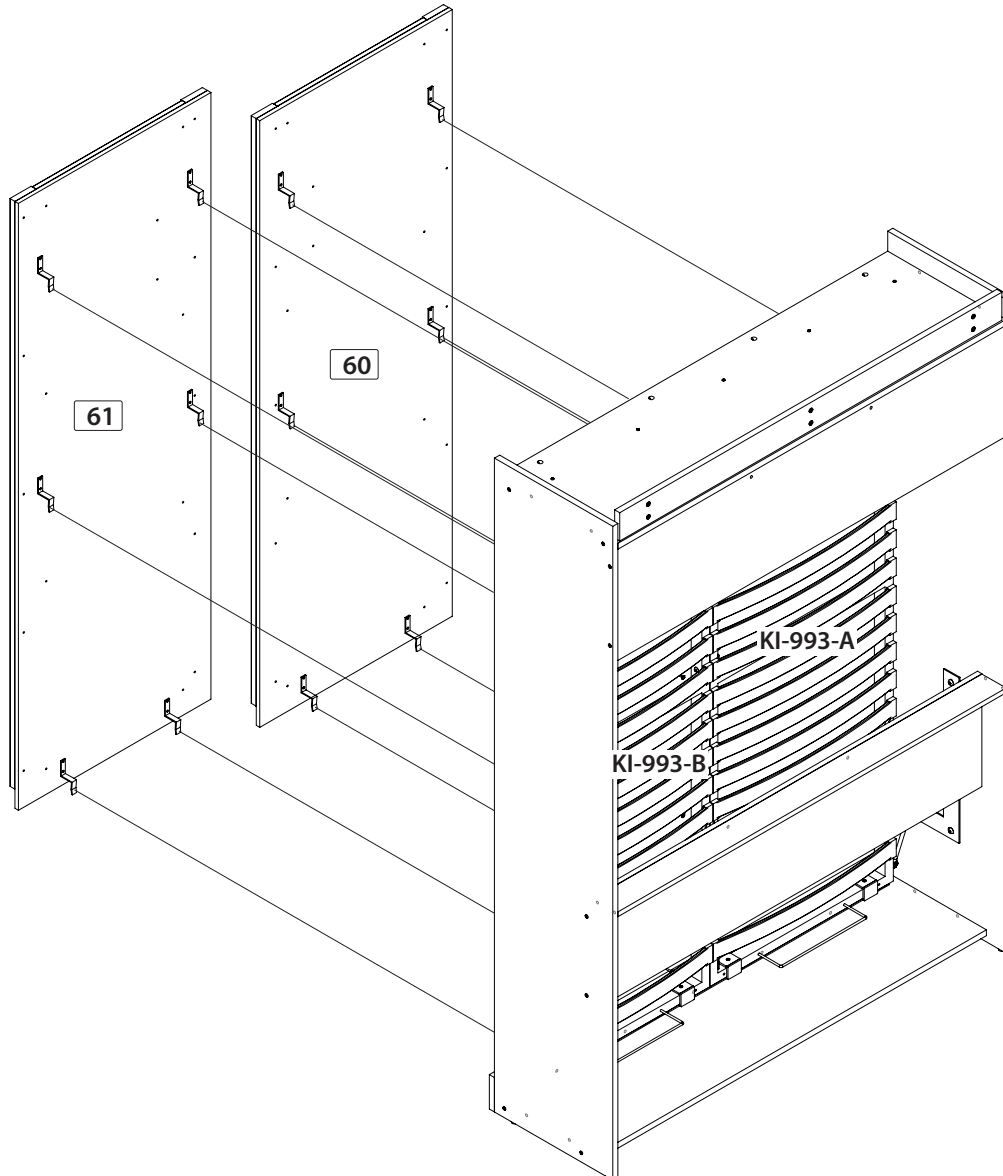

### Important/Importante

Refer to step 16 for details.

Référez-vous à l'étape 16 pour plus de détails.

Consulte el paso 16 para obtener más información.

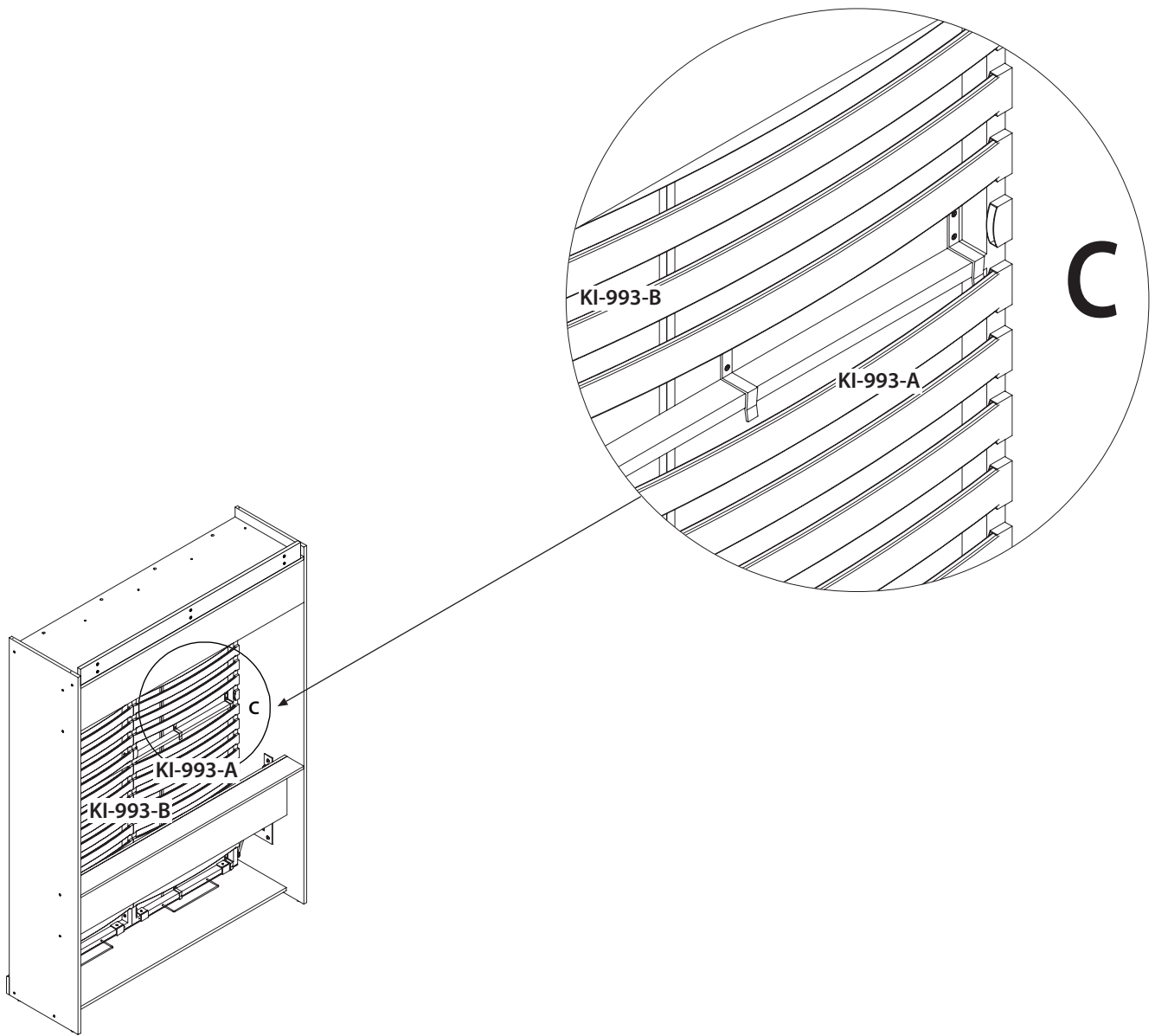

**CAUTION / ATTENTION / ATENCIÓN**

Please open the leg before completely lower the bed.

Veuillez ouvrir la patte avant d'abaisser complètement le lit.

Por favor, abra la pierna delantera bajar completamente la cama.

**Important/Importante**

Center the bed before screwing in parts 60 and 61.

Centrez le lit avant de visser dans les pièces 60 et 61.

Centre la cama antes de atornillar las piezas 60 y 61.

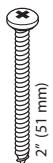
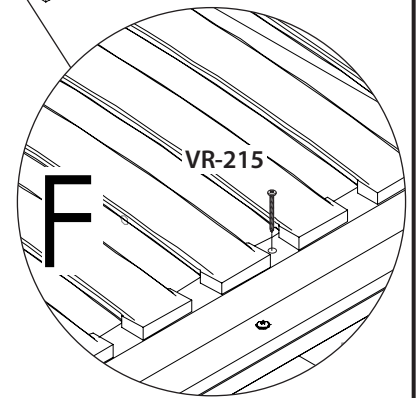
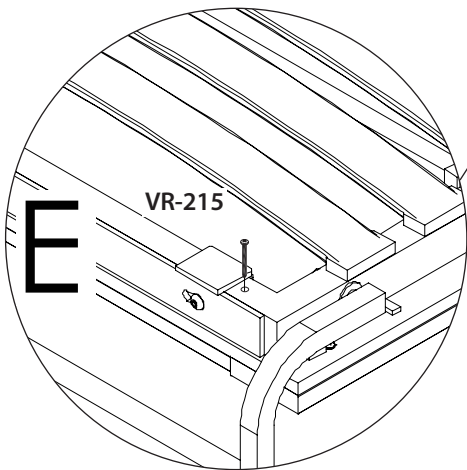
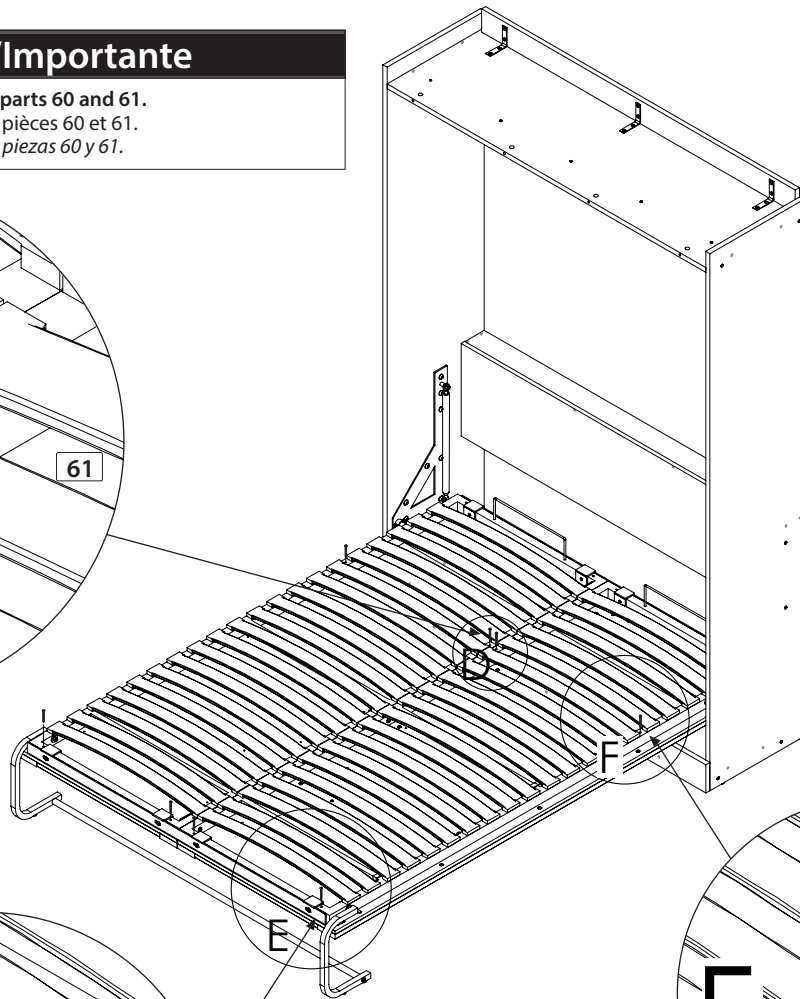
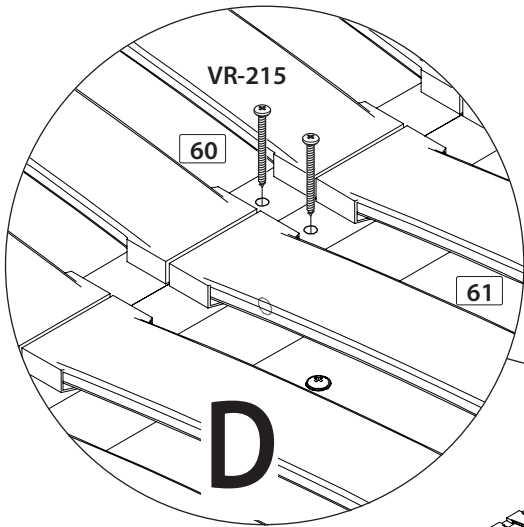

Code / Código

VR-215

Qty / Qté / Cant.

x 8



Assembling sequence  
 Séquence d'assemblage  
 Secuencia de ensamblaje  
 Parts / Pièces / Piezas:

41 + 85

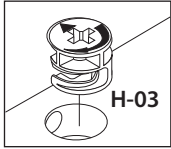

H-03

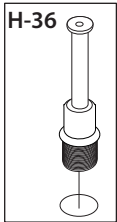

H-36

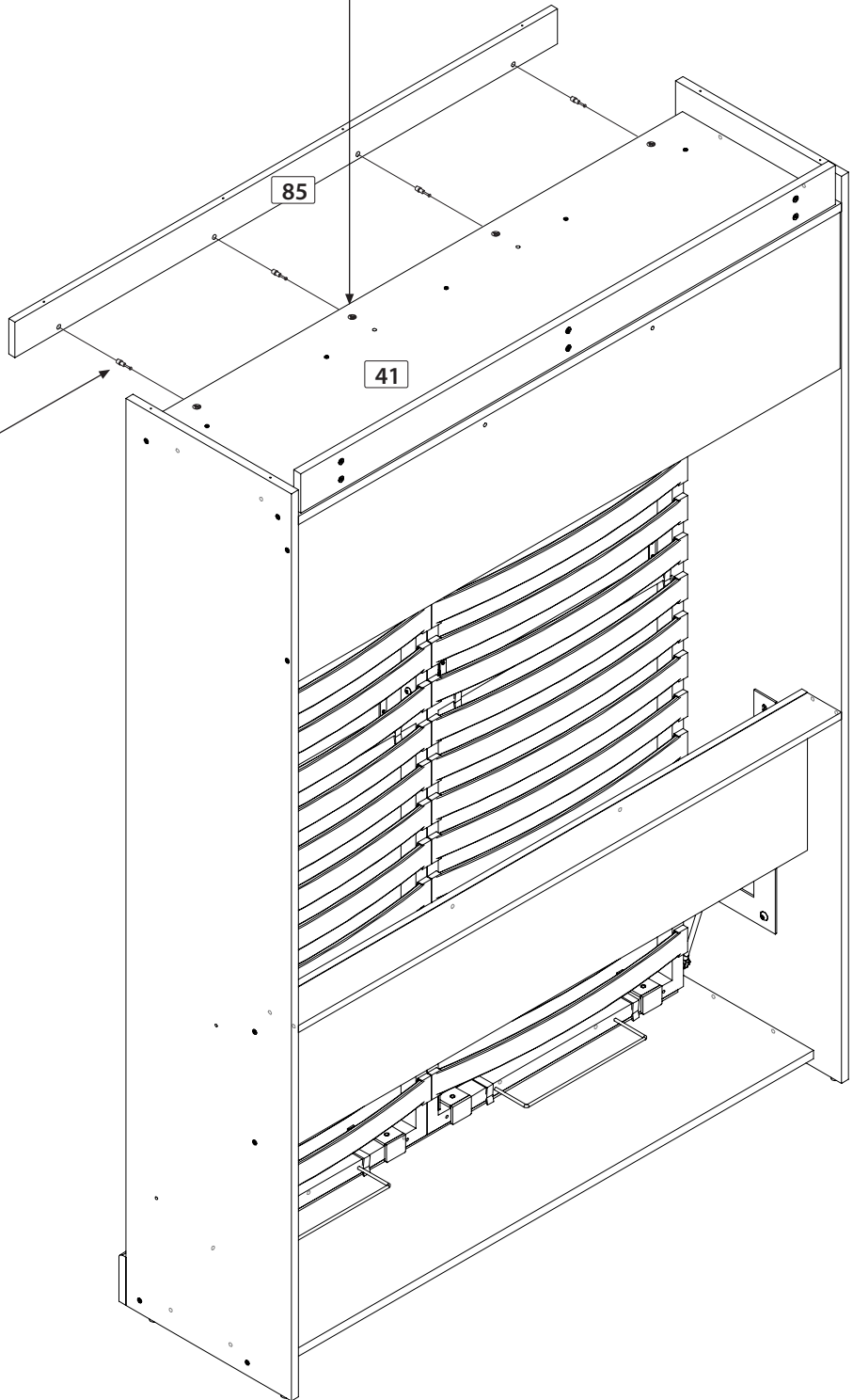

Code / Código



H-03

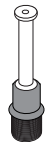

H-36

Qty / Qté / Cant.

x 4

x 4

If you bought sets 40890 to 40896 and you want to place them side by side, please use this illustration as a replacement for the head moulding.

Si vous avez acheté l'ensemble 40890 à 40896 et que vous voulez les mettre côte-à-côte, veuillez utiliser ces illustrations pour l'installation de la moulure de tête.

## 19 PRE-ASSEMBLY / PRÉ-ASSEMBLAGE

Wall Bed / Lit escamotable

Assembly sequence

Séquence d'assemblage

Parts / Pièces :

40822 + 40183

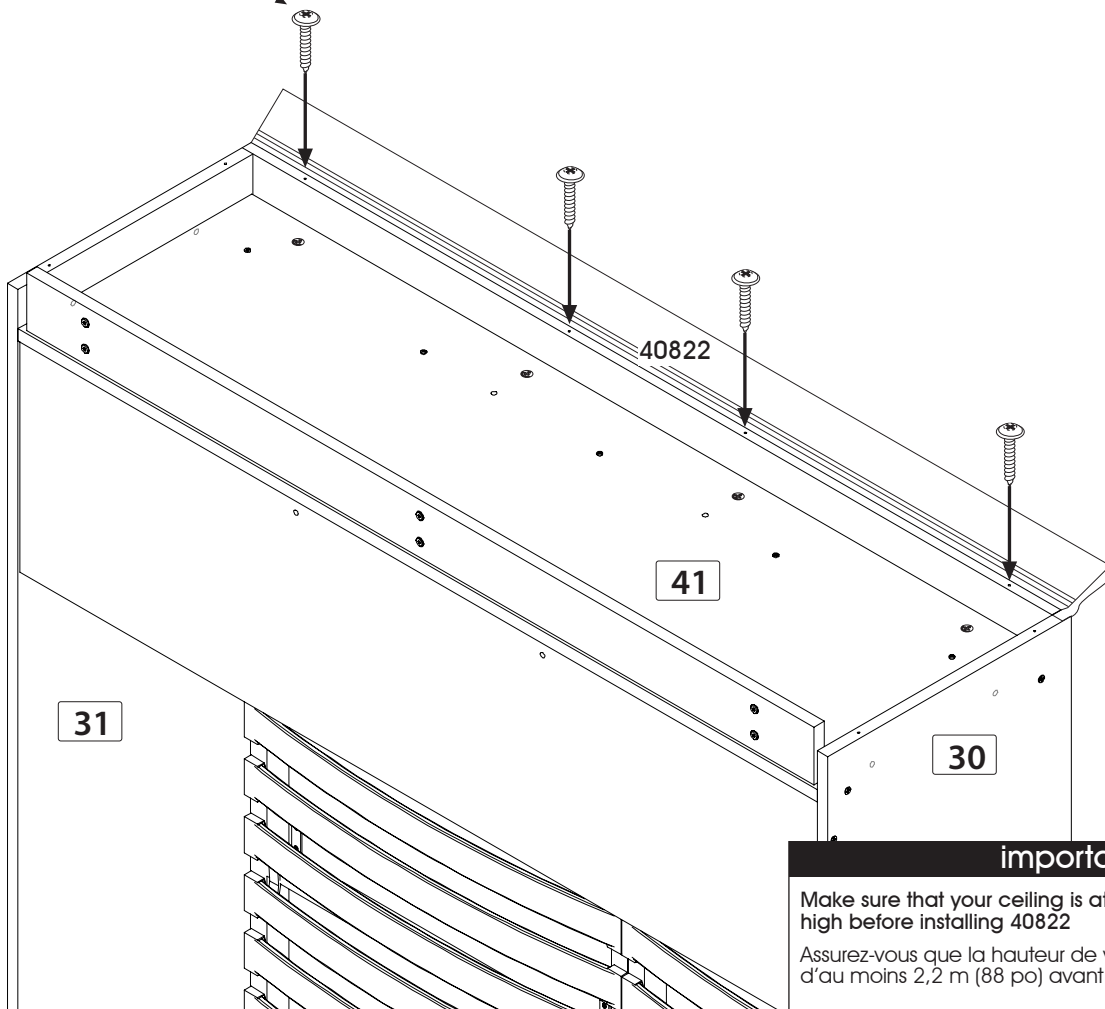
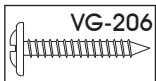

### important

Make sure that your ceiling is at least 2.2 m (88 in.) high before installing 40822

Assurez-vous que la hauteur de votre plafond est d'au moins 2,2 m (88 po) avant d'installer le 40822

19



Code 40822

VG-206

Qty / Qté x 1

x 4

**Assembling sequence**  
 Séquence d'assemblage  
 Secuencia de ensamblaje



Parts / Pièces / Piezas:

30 85 31 + MO-942GA MO-7453 MO-942DR

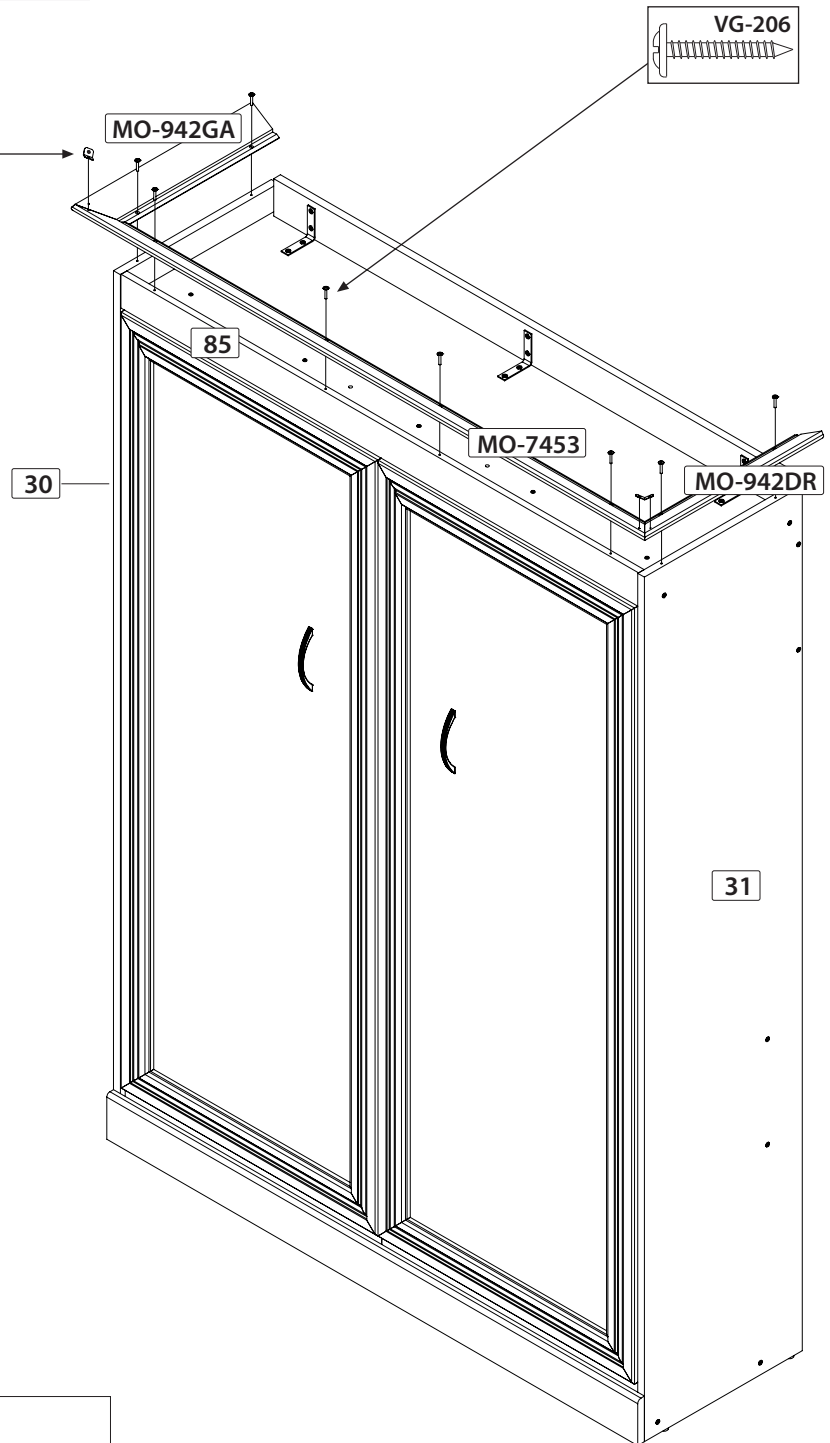
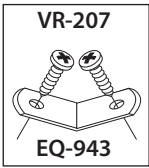

**IMPORTANT / IMPORTANTE**

Assure that the height of the ceiling is at least 93" (2362 mm) before installing the mouldings. Install the mouldings before or after having raised the bed according to the height of the ceiling.

Assurez-vous que la hauteur du plafond est d'au moins 93" (2362 mm) avant d'installer les moulures. Installez les moulures avant ou après avoir relevé le lit selon la hauteur du plafond.

Asegúrese que la altura del techo es de por lo menos 93" (2362 mm) antes de instalar las molduras. Instale las molduras antes o después haber levantado la cama según la altura del techo.

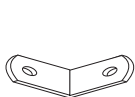

Code / Código	EQ-943	VG-206	VR-207
Qty / Qté / Cant.	x 2	x 8	x 4

## IMPORTANT NOTICE / NOTE IMPORTANTE / NOTA IMPORTANTE

**After you have finished assembling your wall bed, please keep the assembly book by placing it under the mattress, in the frame of the mobile part of the bed.**

Lorsque l'assemblage de votre lit escamotable est terminé, veuillez conserver le feuillet d'instructions en le plaçant sous le matelas, dans le cadre de la partie mobile du lit.

*Cuando el ensamble de su cama se acaba, por favor, conserve la hoja de instrucciones colocándolo bajo el colchón, en el marco de la parte móvil de la cama.*

**After you have finished assembling your wall bed, close it. If the gap around the bed is uneven, push or gently kick the base of the CABINET on the side with the NARROWEST gap until desired gap is obtained.**

Lorsque l'assemblage de votre lit escamotable est terminé, fermez le lit. Si l'espace autour du lit est décentré, poussez ou frappez délicatement sur la BASE du côté où l'espace est le plus MINCE jusqu'à ce que l'espace désiré soit obtenu.

*Cuando el ensamble de su cama se acaba, por favor, cama cercana. Si el espacio alrededor de la cama es descentrado, crezca o llame delicadamente teniendo como base el lado donde el espacio más DELGADO hasta que el espacio deseado sea obtenido.*

## RECOMMENDATION / RECOMMANDATION / RECOMENDACIÓN

**Maintain the bed closed when not used.**

**It is recommended not to leave pillows and/or ornamental pillows in place when the bed is closed to preserve the mechanism.**

Maintenir le lit fermé lorsque non utilisé.

Il est recommandé de ne pas laisser les oreillers et/ou coussins décoratifs en place lorsque le lit est fermé afin de préserver le mécanisme de bascule.

Mantener la cama cerrada si cuando no utilizado.

Es recomendado no dejar las almohadas y/o los cojines decorativos en plaza cuando la cama es cerrada con el fin de preservar el mecanismo de báscula.

▶ **IMPORTANT NOTICE / NOTE IMPORTANTE / NOTA IMPORTANTE**

**When you have completed the assembly of your new furniture, install the plastic caps**

Lorsque vous avez complété l'assemblage de votre meuble, installez les capuchons de plastique

*Una vez que haya ensamblado el mueble, coloque los capuchones de plástico.*

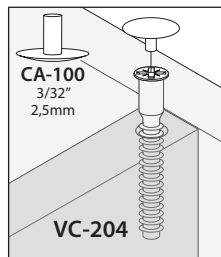

**PRODUCT CARE / ENTRETIEN DU PRODUIT / MANTENIMIENTO DEL PRODUCTO**

**Avoid placing the furniture in the sunlight or near a source of heat. Use a soft dry cloth for dusting. To clean heavy dirt, use a cloth dipped in a solution of mild detergent and water. Avoid leaving wet objects on the surface or using commercial chemical cleaning products.**

Évitez d'exposer le meuble au soleil ou près de toute source de chaleur. Pour le nettoyage, utilisez un chiffon doux et sec. Pour la grosse saleté, utilisez un chiffon humide avec un peu de détergent dilué dans l'eau. Évitez de laisser des objets mouillés sur la surface de votre meuble ou d'utiliser des nettoyeurs chimiques.

*Evite exponer el mueble al sol o las fuentes de calor. Para limpiarlo, utilice un paño suave y seco. Para limpiar las manchas rebeldes, utilice un trapo húmedo con un poco de detergente diluido en agua. No deje objetos mojados encima del mueble ni utilice limpiadores que contengan productos químicos.*



**For more information or to discover our new products**

Pour toute information ou pour découvrir nos nouveaux produits

*Para más información o descubrir nuestros nuevos productos*



**FOR LONG TIME**  
**POUR LONGTEMPS**  
*POR MUCHO TIEMPO*